

EXPLODED VIEW & PARTS LISTING

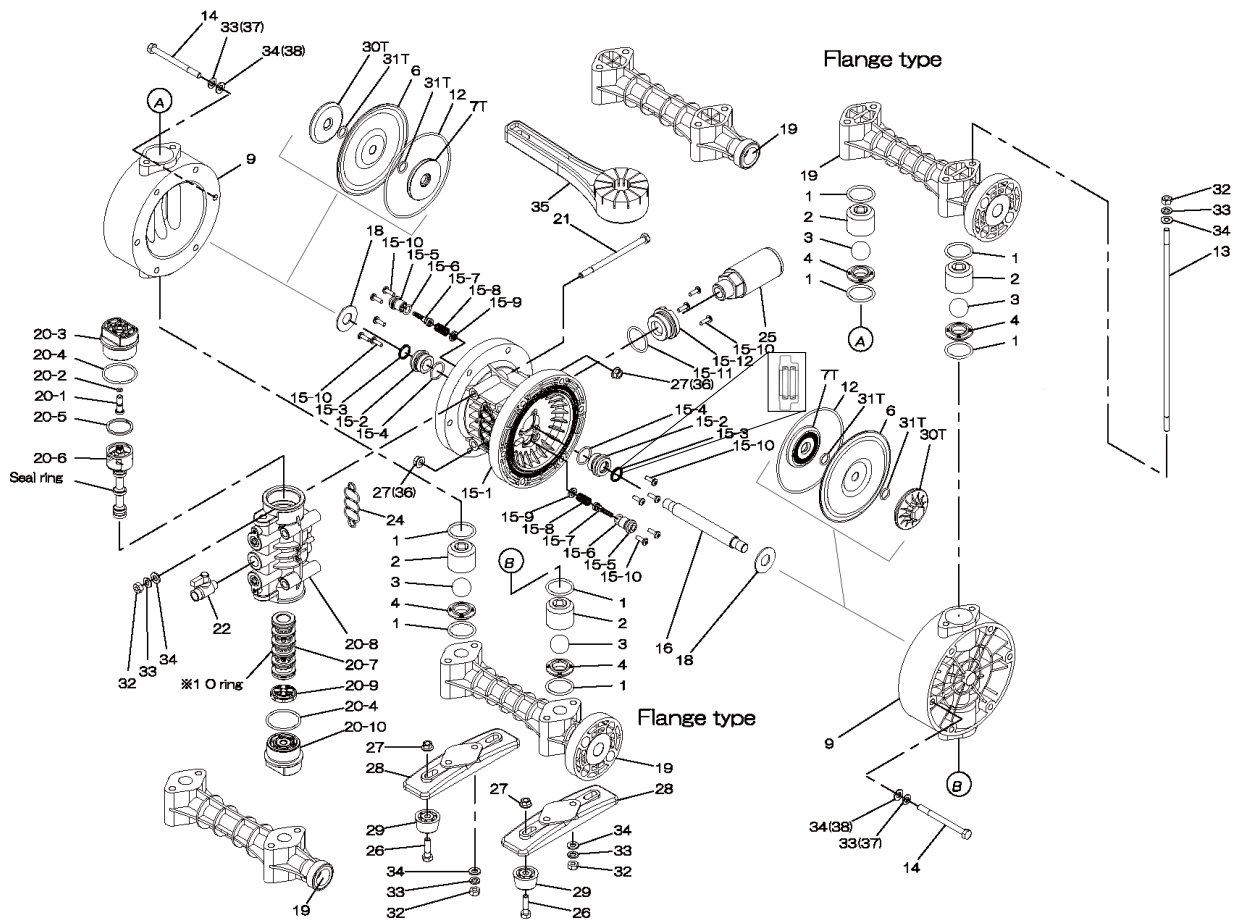

Air Operated Double Diaphragm Pump

Model: NDP-25BPT-PP
 Model# 854175 (NPT)
 Model# 854189 (Flange)

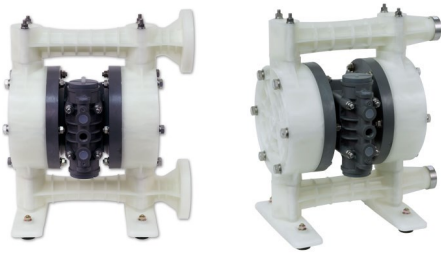

Air Operated Double Diaphragm Pump

NDP-25BPT-PP

REF. No.	PARTS No.	DESCRIPTION	QTY.	REORDER
NPT	854175	** NPT PUMPS **		
Flange	854189	** FLG PUMPS **		
1	643042	O-RING	8	
2	771231	BALL GUIDE	4	
3	770691	BALL	4	
4	780138	VALVE SEAT	4	
6	771110	DIAPHRAGM	2	
7T	709459	CENTER DISK	2	
9	780135	OUT CHAMBER	2	
12	640154	O-RING	2	
13	710207	TIE ROD	4	
14	683541	BOLT	12	
15	804604	BODY ASSY.	1	
15-1	772929	BODY	1	
15-2	780326	THROAT BEARING	2	
15-3	685414	V-PACKING	2	
15-4	685276	O-RING	2	
15-5	772932	PILOT VALVE SEAT	2	
15-6	640009	O-RING	2	
15-7	802360	PILOT VALVE ASSY.	2	
15-8	708666	SPRING	2	
15-9	772948	SPRING SEAT	2	
15-10	686030	TAPPING SCREW	13	
15-11	640132	O-RING	1	
15-12	772933	BUSHING	1	
16	710271	CENTER ROD	1	
18	771054	CUSHION	2	
19	780012	MANIFOLD NPT	2	
19	780210	MANIFOLD FLG	2	
20	804608	VALVE BODY ASSY.	1	
20-1	772991	RESET BUTTON	1	
20-2	640002	O-RING	1	
20-3	772946	CAP A	1	
20-4	640043	O-RING	2	
20-5	771241	PACKING	1	
20-6	802400	C-SPOOL ASSY.	1	
20-6-seal	771053	SEAL RING	5	
20-7	804609	SLEEVE ASSY	1	
20-7-*1	686029	O-RING	6	
20-8	832903	VALVE BODY ASSY.	1	
20-9	771914	CUSHION	1	
20-10	772947	CAP B	1	
21	686031	BOLT	4	
22	686970	BALL VALVE	1	
24	772848	GASKET	1	
25	804697	MUFFLER	1	
26	621153	BOLT	4	
27	686032	NUT W/FLANGE	4	
28	771235	BASE	2	
29	770551	FOOT RUBBER	4	
30T	780126	CENTER DISK	2	
31T	643013	O-RING	4	
32	683635	NUT	12	
33	681300	SPRING WASHER	12	
34	631329	FLAT WASHER	12	
35	771244	TOOL	2	
36	686033	NUT W/FLANGE	12	
37	680257	SPRING WASHER	12	
38	631330	FLAT WASHER	12	
KIT	K25-PT-PP	Liquid Side Kit		
KIT	K225-AP	Air Motor Kit		

NOTE: 804647 = CENTER BODY ASSEMBLY (804604 + 804608)

General Tools:

- Socket wrenches - 10mm, 12mm, 13mm, 17mm, 22mm
- Hexagonal box wrench - 5mm
- Open-end wrenches - 12mm, 13mm, 22mm
- Adjustable angle wrenches
- Phillips head screw driver

Special Tools:

- Disk remover (771244). (included)
- Sleeve remover (713148). (sold separately)

Miscellaneous:

- Assembly Oil - turbine oil none additional class 1 (equivalent to ISO VG32 grade)
- Nuts - M14 x 1.5
- Urea grease grade (NLGI) No. 2

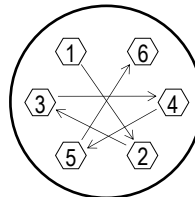

Tightening torque for center rod and out chambers.

Center Rod 29 ft-lbf {40 N-m}
 Out Chambers 15 ft-lbf {20 N-m}

Tightening torque for manifold retainer nuts.

BPT-PP 25 ft-lbf {35 N-m}

Customer Notes

Model #: _____
 Description: _____
 Serial #: _____
 Date Installed: _____
 Department Location: _____
 Tag/Project: _____