

EXPLODED VIEW & PARTS LISTING

Air Operated Double Diaphragm Pump

Model: NDP-25BPT
Model#: 851672 (NPT)
Model#: 853848 (Flange)

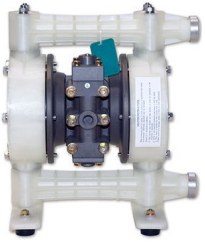

Trial Program

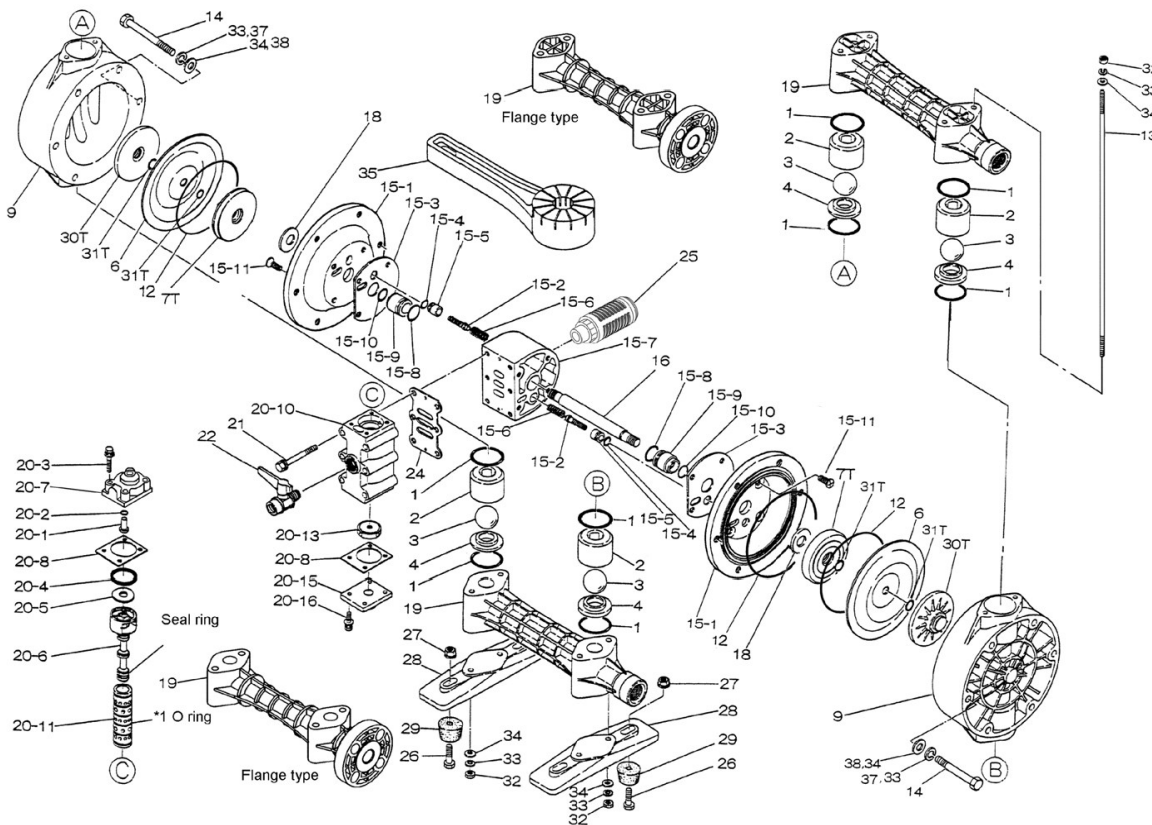

EXPLODED VIEW & PARTS LISTING

Air Operated Double Diaphragm Pump

Model: NDP-25BPT
 Model#: 851672 (NPT)
 Model#: 853848 (Flange)



REF. NO.	PART NO.	DESCRIPTION	QTY	REORDER
NPT	851672	** NPT PUMPS **		
Flange	853848	** FLG PUMPS **		
1	643042	O RING 43.7MM X 3.5MM	8	
2	771231	BALL GUIDE 25PP	4	
3	770691	BALL 25T -35MM PTFE	4	
4	780138	VALVE SEAT 25PP	4	
6	771110	DIAPHRAGM (PTFE) 25	2	
7T	709459	CENTER DISK 25T	2	
9	780135	OUT CHAMBER 25PP	2	
12	640154	O RING	2	
13	710207	TIE ROD 25PP	4	
14	621189	BOLT M10X1.50X90 HET	12	
15	804880	CENTER BODY ASSY.	1	
15- 1	715940	AIR CHAMBER	2	
15- 2	802360	PILOT VALVE ASSY 20/25	2	
15- 3	771057	GASKET 20/25	2	
15- 4	640009	O RING 11MM X 2.5MM	2	
15- 5	771945	PILOT VALVE SEAT 20/25	2	
15- 6	708666	SPRING 20/25	2	
15- 7	711503	BODY 20/25 PP	1	
15- 8	685276	O RING 23.3MMX2.4MM	2	
15- 9	772703	THROAT BEARING 20/25	2	
15-10	685414	V-PACKING 20/25	2	
15-11	682486	BOLT FLAT HD W/ WASHER	8	
16	710271	CENTER ROD 25P&V	1	
18	771054	CUSHION 20/25	2	
19	780012	MANIFOLD 25PP	2	
20	802809	AIR VALVE ASSY.	1	
20- 1	709161	RESET BUTTON 20/25	1	
20- 2	640005	O RING 7.5MM X 2.0MM	1	
20- 3	682704	BOLT M6 FT ZINC W/ WASHER	4	
20- 4	771241	PACKING 20/25	1	
20- 5	715961	WASHER	1	
20- 6	802400	C SPOOL ASSY	1	
20-6 seal	771053	SEAL RING	5	
20- 7	711219	CAP A 20/25PP	1	
20- 8	771240	GASKET 20/25	2	
20-10	711640	VALVE BODY 20/25PP	1	
20-11	803931	SLEEVE ASSY	1	
20-11-*1	771080	O-RING	6	
20-13	771914	CUSHION 20/25	1	
20-15	711212	CAP B 20/25PP	1	
20-16	682262	BOLT M6 FT ZINC W/ WASHER	4	
21	682265	BOLT M8 PT ZINC W/ WASHER	6	
22	684320	BALL VALVE 25&25F 3/8	1	
24	771056	GASKET 20/25	1	
25	804697	MUFFLER 20/25PP NEW	1	
26	611153	BOLT M8X1.25X35 HEX FT	4	
27	682276	NUT W/ FLANGE M8 X 1.2	4	
28	771235	BASE 25PP	2	
29	770551	FOOT RUBBER 15PP,20/25	4	
30T	780126	CENTER DISK 25PP-T	2	
31T	643013	O RING 13.8MM X 2.4MM	4	
32	683635	NUT 10/20F&20/25 M8X1	8	
33	681300	SPRING WASHER M8 SS	8	
34	631329	WASHER FLAT M8 SS	8	
35	771244	TOOL 20/25PP&V	2	
37	680257	SPRING WASHER M10 SS	12	
38	631330	WASHER FLAT M10 SS	12	
KIT	ORDER PARTS INDIVIDUALLY	LIQUID END KIT		
KIT	K225-AM	AIR MOTOR KIT		

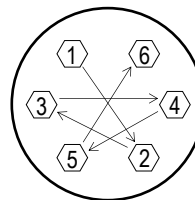

Tightening torque for center rod and out chambers.

Center Rod 29 ft-lbf {40 N-m}
 Out Chambers 15 ft-lbf {20 N-m}

Tightening torque for manifold retainer bolts.

BPT 10 ft-lbf {12 N-m}

General Tools:

- Socket wrenches - 10mm, 12mm, 13mm, 17mm, 22mm
- Hexagonal box wrench - 5mm
- Open-end wrenches - 13mm

Special Tools:

- Disc remover (771244) used for removing the center disk
- Sleeve remover (713148) used for removing the sleeve.

Miscellaneous:

- Assembly Oil - turbine oil none additional class 1 (equivalent to ISO VG32 grade)
- Nuts - M14 x 1.5
- Urea grease grade (NLGI) No. 2
- Lubricants equivalent to (Loctite Anti-Seize 767)

Customer Notes

Model #: _____
 Description: _____
 Serial #: _____
 Date Installed: _____
 Department Location: _____
 Tag/Project: _____