

Air Operated Double Diaphragm Pump

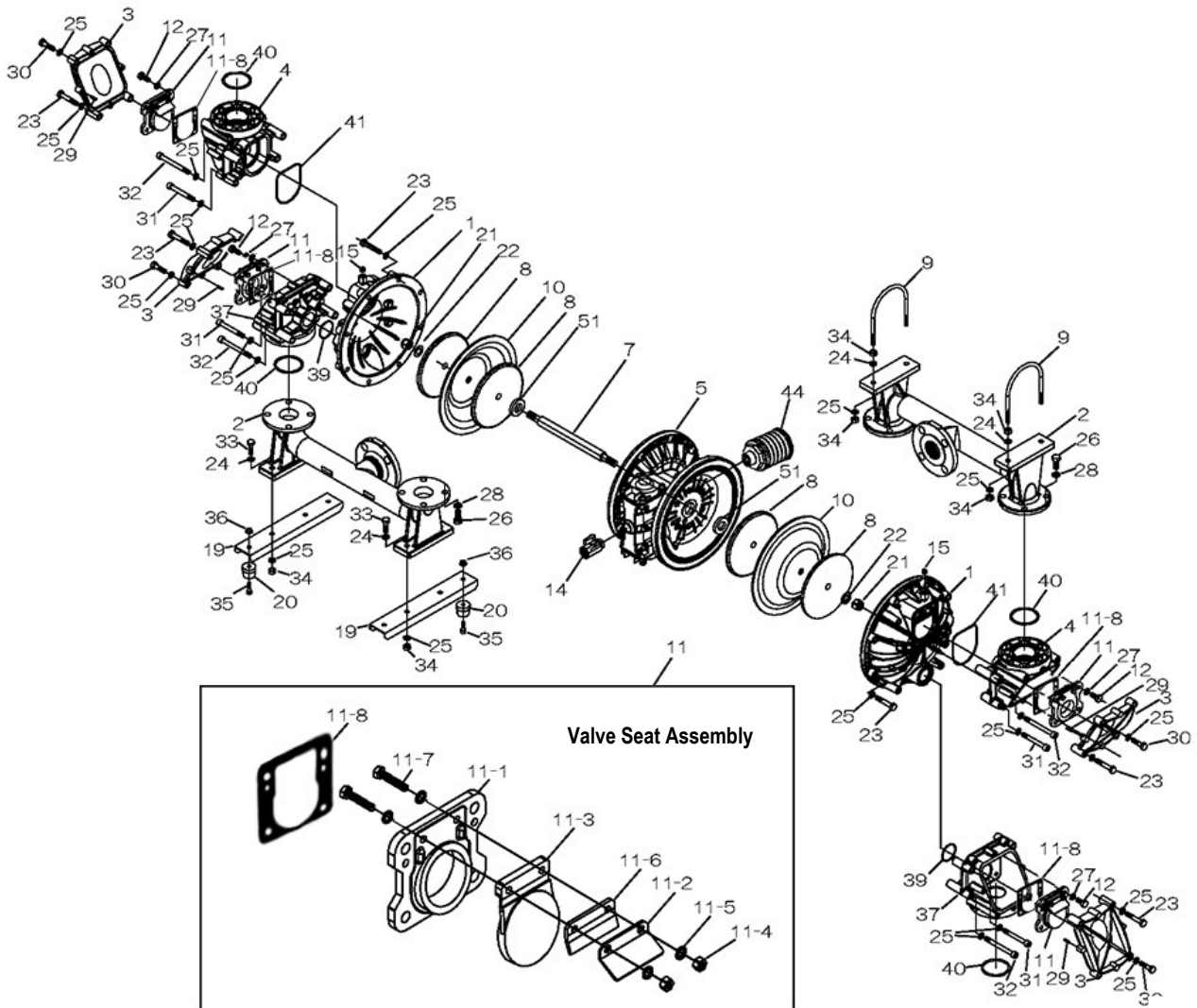

Air Operated Double Diaphragm Pump

Center Body Assembly

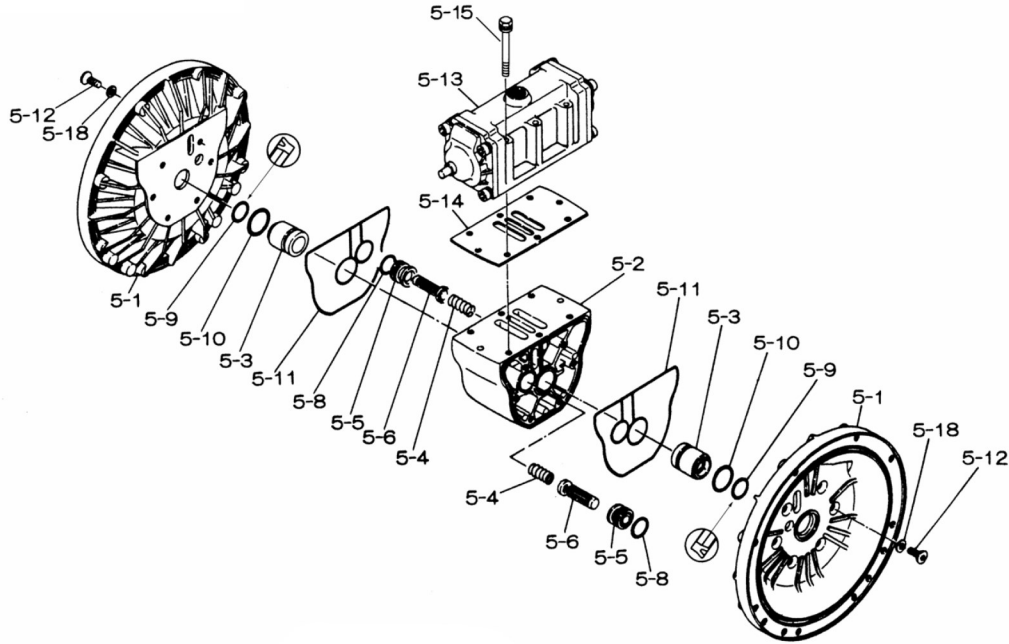

Valve Body Assembly

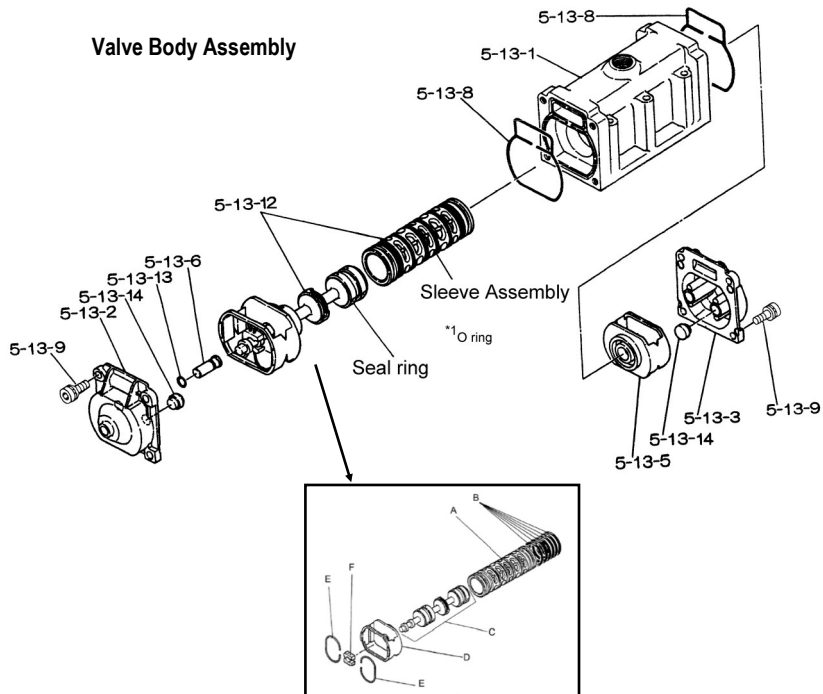

Air Operated Double Diaphragm Pump

REF. NO.	PART NO	DESCRIPTION	QTY.	REORDER
1	716032	OUT CHAMBER	2	
2	715767	IN MANIFOLD	2	
3	795117	VALVE CASE COVER	4	
4	716030	IN VALVE CASE	2	
5	804719	CENTER BODY ASSEMBLY	1	
5- 1	711934	AIR CHAMBER	2	
5- 2	711936	BODY	1	
5- 3	780325	THROAT BEARING	2	
5- 4	711937	PILOT VALVE SPRING	2	
5- 5	771740	PILOT VALVE SEAT	2	
5- 6	832163	PILOT VALVE ASSEMBLY	2	
5- 8	640020	O-RING	2	
5- 9	685444	V-PACKING	2	
5-10	640029	O-RING	2	
5-11	771742	GASKET	2	
5-12	683812	FLAT SOCKET	12	
5-13	802971	VALVE BODY ASSEMBLY	1	
5-13-1	711931	VALVE BODY	1	
5-13-2	580999	CAP A	1	
5-13-3	581000	CAP B	1	
5-13-5	771735	SPRING RETAINER	1	
5-13-6	712976	RESET BUTTON	1	
5-13-8	771738	GASKET	2	
5-13-9	685036	SOCKET BOLT	8	
5-13-12	805084	C-SPOOL ASSEMBLY	1	
A	803675	SLEEVE ASSEMBLY	1	
B	640036	O-RING	6	
C	805085	SPOOL ASSY	1	
D	771735	SPRING RETAINER	1	
E	711932	C-SPRING	2	
F	771734	BLOCK	1	
5-13-13	640005	O-RING	1	
5-13-14	684128	CUSHION	4	
5-14	771712	GASKET	1	
5-15	684240	BOLT WWASHERS	6	
5-18	684987	WASHER	12	
7	711900	CENTER ROD	1	
8	711904	CENTER DISK	4	
9	686099	U BOLT	2	
10	771976	DIAPHRAGM	2	

REF. NO.	PART NO	DESCRIPTION	QTY.	REORDER
11	804841	VALVE SEAT ASSEMBLY	4	
11-1	795115-AL	VALVE SEAT	1	
11-2	715765	VALVE STOPPER	1	
11-3	795125-TPO	FLAP VALVE	1	
11-4	685184	NUT	2	
11-5	631172	PLAIN WASHER	4	
11-6	773000	HINGE PAD	1	
11-7	621106	BOLT	2	
11-8	50FA01	GASKET FOR VALVE SEAT	4	
12	621173	BOLT	16	
14	684322	BALL VALVE	1	
15	686100	PLUG	2	
19	716078	PUMP BASE	2	
20	771402	CUSHION	4	
21	683408	NUT	2	
22	682740	CONED DISK SPRING	2	
23	686045	BOLT	24	
24	631014	PLAIN WASHER	8	
25	631917	SPRING LOCK WASHER	32	
26	611197	BOLT	16	
27	631937	WAVE WASHER	16	
28	631918	WAVE WASHER	16	
29	686169	PIN	8	
30	611179	BOLT	8	
31	619188	BOLT	8	
32	686158	HEX SOCKET SCREW	8	
33	611177	BOLT	4	
34	627013	NUT	12	
35	611149	BOLT	4	
36	682276	NUT WITH FLANGE	4	
37	716031	OUT VALVE CASE	2	
39	640045	O-RING	2	
40	683998	O-RING	4	
41	772941	GASKET	2	
51	770582	CUSHION	2	
KIT	K50-FMS	LIQUID SIDE KIT		
KIT	K80-AM	AIR MOTOR KIT		

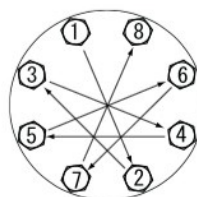

Tightening torque for center rod and out chambers.

- Center Rod 43 ft-lbf {60 N-m}
- Out Chambers 36 ft-lbf {12 N-m}
- Valve Case Cover 22 ft-lbf {30 N-m}

Tightening torque for manifold retainer bolts.

NDP-50FAS 15 ft-lbf {20 N-m}

General Tools:

- Socket wrench - 10mm, 13mm, 17mm, 19mm, 24mm,
- Hexagonal box wrenches - 5mm, 6mm, 8mm, 1/4 inch
- Small crowbars - 2
- Snap ring pliers 12-25mm

Miscellaneous:

- Assembly Oil—turbine oil none additional class 1 (equivalent to ISO VG32 grade)
- Nuts—M8 x 1.25 (BS_)
- Urea grease grade (NLGI) No. 2

Customer Notes

Model #: _____

Description: _____

Serial #: _____

Date Installed: _____

Department Location: _____

Tag/Project: _____