

BALDOR® • ***RELIANCE***

Product Information Packet

CEWDM22976T

7.5HP, 1180RPM, 3PH, 60HZ, 254TC, 3954M, TEFC

Part Detail							
Revision:	N	Status:	PRD/A	Change #:		Proprietary:	No
Type:	AC	Prod. Type:	3954M	Elec. Spec:	39WGX718	CD Diagram:	CD0005
Enclosure:	TEFC	Mfg Plant:		Mech. Spec:	39R098	Layout:	39LYR098
Frame:	254TC	Mounting:	F1	Poles:	06	Created Date:	06-16-2010
Base:	RG	Rotation:	R	Insulation:	F	Eff. Date:	05-23-2016
Leads:	9#12					Replaced By:	
Literature:		Elec. Diagram:					

Parts List		
Part Number	Description	Quantity
SA198662	SA 39R098X718G1	1.000 EA
RA186025	RA 39R098X718G1	1.000 EA
09FN3001D01	EXTERNAL FAN, PLASTIC	1.000 EA
S/P107-000-005	SUPER-E PROC'S(254/6 FR.) ZK PLANT - POL	1.000 EA
MJ5002A01	SILICON RUBBER SEALANT, 732CL 10.3 OZ TU	0.025 EA
09GS1017	GASKET, CONDUIT BOX, .125 THICK BLACK NE	1.000 EA
HA6016WP	ADAPTER, CONDUT BOX, W/WHITE EPOXY, PRIM	1.000 EA
09GS1006	GASKET, CONDUIT BOX, NEOP-1/16 THICK-BLA	1.000 EA
09CB3002A01P	CB MACH - 1.25 N.P.T. LEAD HOLE W/EPOXY	1.000 EA
51XW2520A12	.25-20 X .75, TAPTITE II, HEX WSHR SLTD	2.000 EA
HW1001A25	LOCKWASHER 1/4, ZINC PLT .493 OD, .255 I	2.000 EA
WD1000B17	T&B CX35TN TERMINAL	1.000 EA
11XW1032G06	10-32 X .38, TAPTITE II, HEX WSHR SLTD U	1.000 EA
39EP1100A08WP	FR ENDPLATE, MACH W/WHITE EPOXY, PRIMED	1.000 EA
HW5100A08	W3118-035 WVY WSHR (WB)	1.000 EA
HW4600B44	V-RING SLINGER 1.500 X 1.810 X .28 VITON	1.000 EA
HW2502G25	#303 SS,SQ KEY 3/8 X 2.880	1.000 EA
39EP1500A04P	PU ENDPLATE, MACH W/EPOXY PRIMER	1.000 EA
HW4600B53	SEAL 1.688 X 2.275 X 0.312 SINGLE LIP DB	1.000 EA
10XN2520S28	1/4-20X 1 3/4 HEX HD SS X	4.000 EA
HA3154S02	THRUBOLT STUD 3/8-16 X 15.875 SS	4.000 EA
XY3816S12	3/8-16 HEX FINISHED NUT SS	8.000 EA
HA2001B08	SPL SPACER FOR AIR DEFLECTOR .50 O.D. X	3.000 EA
09FH4000A23MWP	FAN COVER, MACH W/WHITE EPOXY	1.000 EA

Parts List (continued)		
Part Number	Description	Quantity
10XN2520S16	41/4-20 X 1 HEX HEAD SS	3.000 EA
09CB3501P	CONDUIT BOX LID FOR 09CB3001 & 09CB3002	1.000 EA
12GS1002	GASKET, CONDUIT BOX LID, NEOP	1.000 EA
19XT2520S12	1/4-20X3/4 HWH NO SLOT TY.23 18-8 S.S.	2.000 EA
HW1001S25	WASHER, 1/4 SPLT LK, STAINLESS STEEL	2.000 EA
HW4600B44	V-RING SLINGER 1.500 X 1.810 X .28 VITON	1.000 EA
MJ5001A27	32220KN GRAY SEALER *MIN BUY 4 QTS=1GAL	0.031 QT
LB1115N	LABEL,LIFTING DEVICE (ON ROLLS)	1.000 EA
LB1164	LABEL,WARNING AND DRAIN	1.000 EA
MN416A01	TAG-INSTAL-MAINT no wire (1200/bx) 11/14	1.000 EA
HA5027A01	HA4066A01 T-DRAIN X2 BAGGED	1.000 EA
HW4032A01	BLACK DRAIN PLUG FOR WASH DOWN MOTORS	3.000 EA
MJ1000A02	GREASE, POLYREX EM EXXON (USe 4824-15A)	0.085 LB
HW4032A01	BLACK DRAIN PLUG FOR WASH DOWN MOTORS	3.000 EA
HW2500A25	WOODRUFF KEY USA #1008 #BLOW CARBON STEE	1.000 EA
51XB1214A20	12-14X1.25 HXWSSLD SERTYB	1.000 EA
MG1025W01	WILKOFAS, 781.01, SIGNAL WHITE #9003	0.050 GA
85XU0407S04	4X1/4 U DRIVE PIN STAINLESS	2.000 EA
LB1119N	WARNING LABEL	1.000 EA
LC0005	CONN.DIA.,TY M,9-LD,DUAL VOLT,REVERSING	1.000 EA
NP1669E	SS WD SUPER-E UL CSA CC REV MTG	1.000 EA
40PA1000	PACKAGING GROUP	1.000 EA

AC Induction Motor Performance Data

Record # 31521 - Typical performance - not guaranteed values

Winding: 39WGX718-R001	Type: 3954M	Enclosure: TEFC
-------------------------------	--------------------	------------------------

Nameplate Data				460 V, 60 Hz: High Voltage Connection	
Rated Output (HP)	7.5			Full Load Torque	33.2 LB-FT
Volts	208-230/460			Start Configuration	direct on line
Full Load Amps	23-22/11			Breakdown Torque	107 LB-FT
R.P.M.	1180			Pull-up Torque	42.9 LB-FT
Hz	60	Phase	3	Locked-rotor Torque	63.1 LB-FT
NEMA Design Code	A	KVA Code	K	Starting Current	75.8 A
Service Factor (S.F.)	1.15			No-load Current	6.02 A
NEMA Nom. Eff.	91	Power Factor	69	Line-line Res. @ 25°C	0.891 Ω
Rating - Duty	40C AMB-CONT			Temp. Rise @ Rated Load	33°C
S.F. Amps				Temp. Rise @ S.F. Load	39°C
				Locked-rotor Power Factor	26
				Rotor inertia	4.34 LB-FT ²

Load Characteristics 460 V, 60 Hz, 7.5 HP

% of Rated Load	25	50	75	100	125	150	S.F.
Power Factor	31	51	63	70	73	74	72
Efficiency	83.8	90.3	91.6	91.6	91.3	90.5	91.4
Speed	1196	1193	1189	1184	1180	1175	1182
Line amperes	6.74	7.71	9.19	11	13.2	15.7	12.3

Performance Graph at 460V, 60Hz, 7.5HP Typical performance - Not guaranteed values

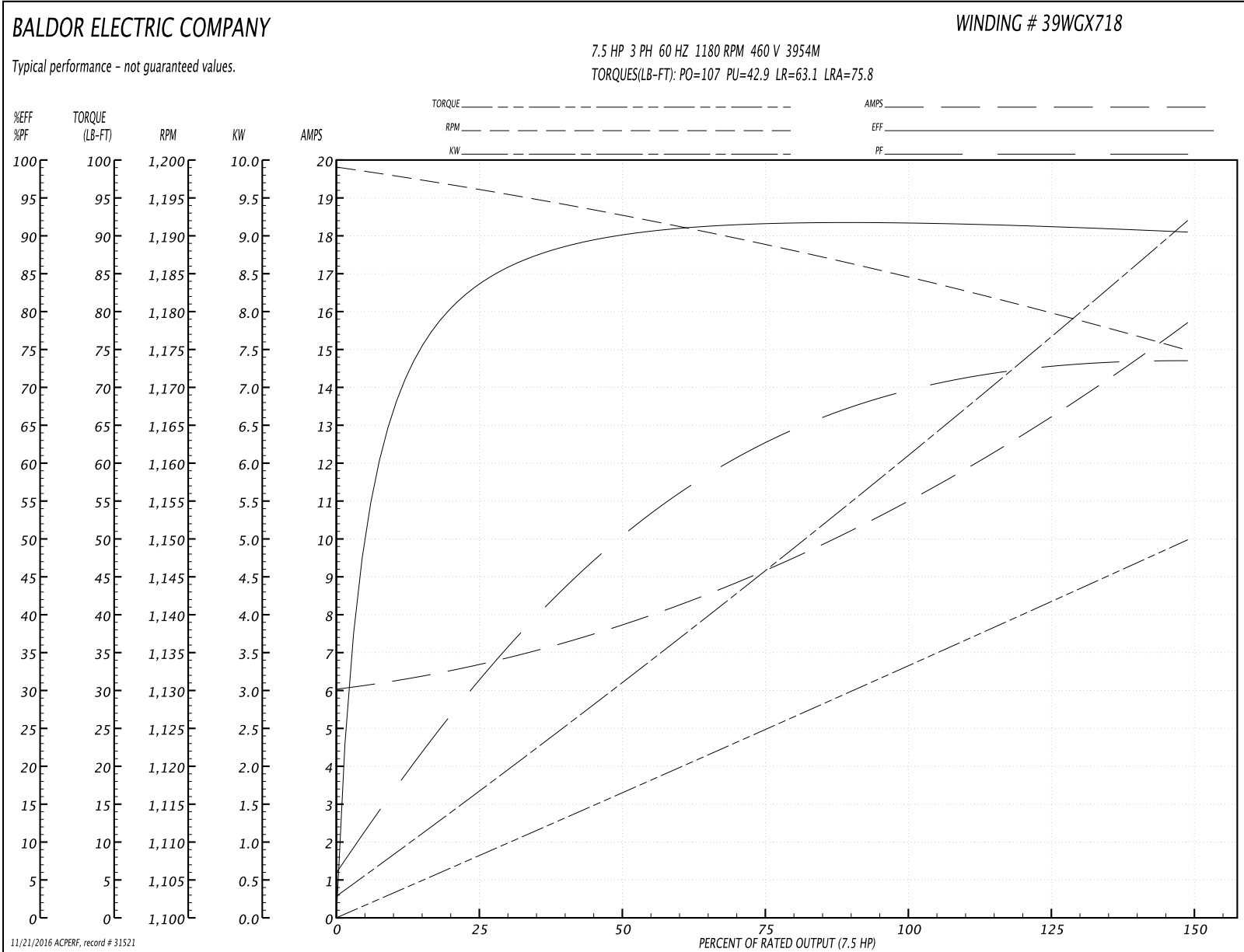

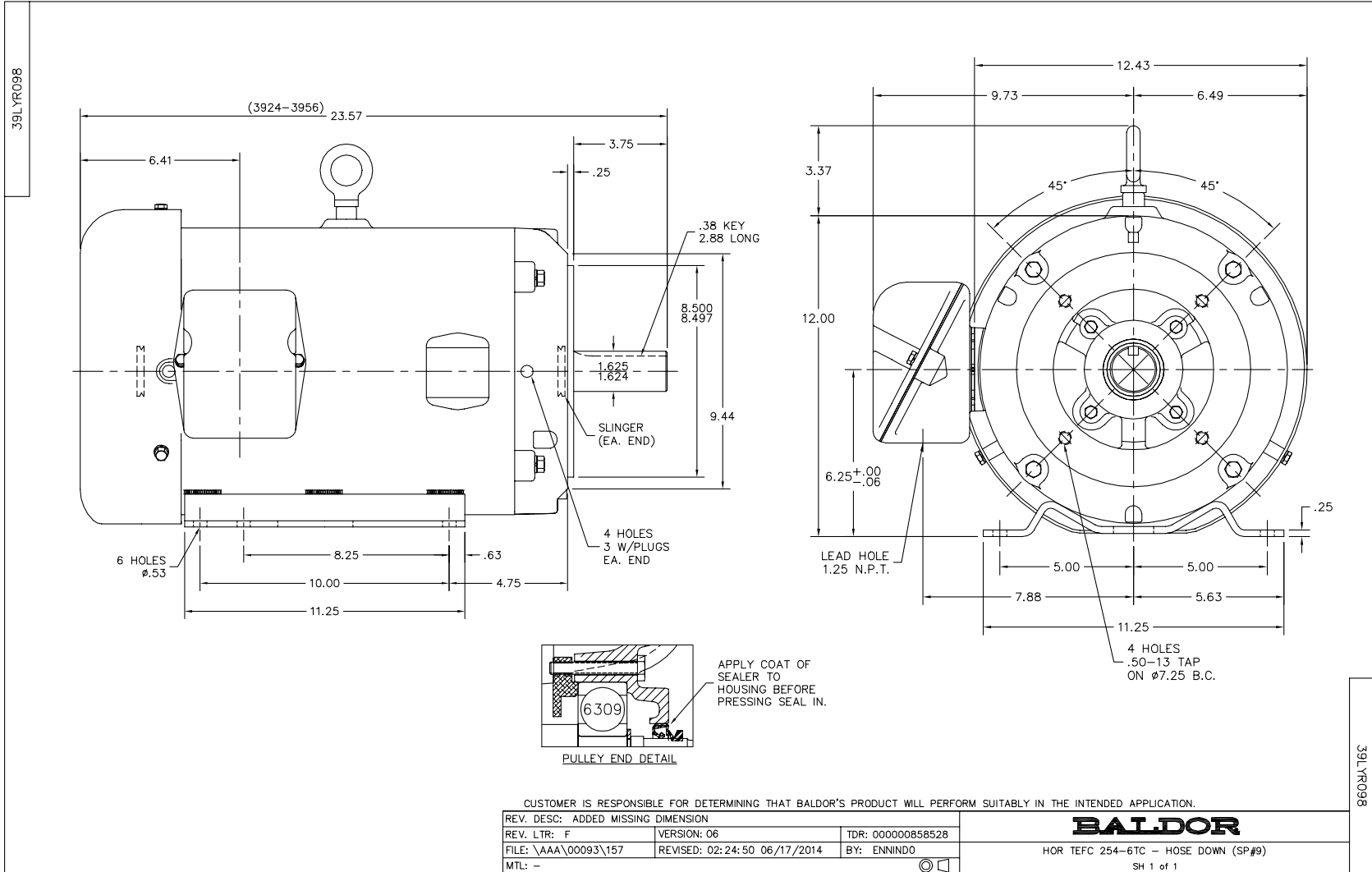

CD0005



LOW VOLTAGE
(2Y)



LINE

HIGH VOLTAGE
(1Y)



LINE

NOTES:

1. INTERCHANGE ANY TWO LINE LEADS TO REVERSE ROTATION.
2. OPTIONAL THERMOSTATS ARE PROVIDED WHEN SPECIFIED.
3. ACTUAL NUMBER OF INTERNAL PARALLEL CIRCUITS MAY BE A MULTIPLE OF THOSE SHOWN ABOVE.
4. LEAD COLORS ARE OPTIONAL. LEADS MUST ALWAYS BE NUMBERED AS SHOWN.

REV. DESC: REVISE TO SHOW OPTIONAL COLORS			
REV. LTR: E	BY: JLP	REVISED: 01/19/99 10:15	TDR: 0171435
90000		FILE: AAA00005140	MDL: -
		MTL: -	

BALDOR ELECTRIC Co.

3PH, DV, 9 LEADS

CD0005