

# SLIDE RAIL COUPLING SRC-3

To be used with  
3" sewage pumps



## LOCATION

This SRC-3 is designed for wet wells, tanks, or lift stations where it is necessary to remove a pump from service and reinstall the pump without maintenance personnel entering the pit to unbolt the pump flanges.

## FEATURES

- ▶ 3" NPT pump connection
- ▶ 3" NPT vertical discharge
- ▶ 1¼" stainless steel guide rails (provided by installer)
- ▶ Stress-free rail system
- ▶ Durable cast iron base and lift-out flange
- ▶ Stainless steel pump adapter and guide plate

## STATIONARY ELBOW

Cast iron ASTM A-48 class 30

## MOVABLE FITTING

Ductile iron ASTM A-536

## GUIDE RAIL CAP

**Bracket:** 304 stainless steel

**Plugs:** ductile iron ASTM A-536-84

## HARDWARE

304 series stainless steel

## O-RINGS

Buna-N, 70 ±5 Duro.

## PAINT

Air dry enamel, water based.

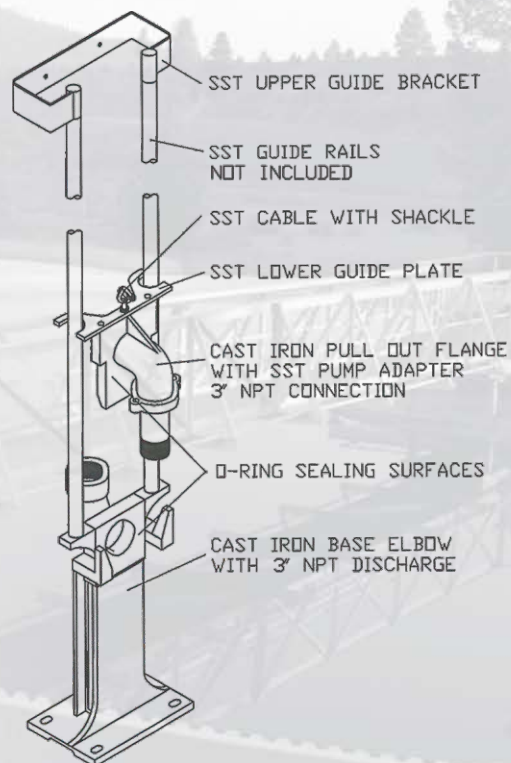

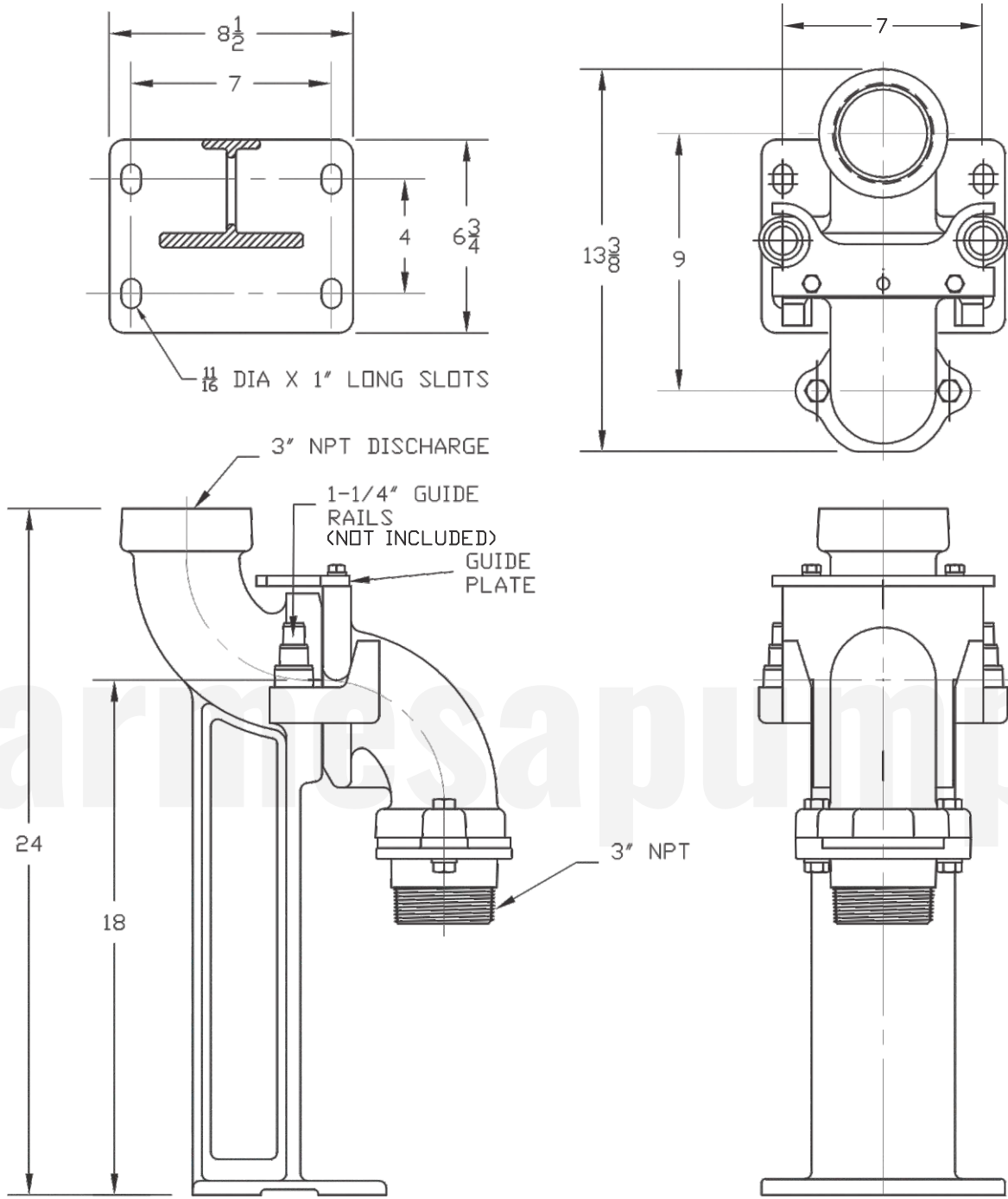

MODEL	PART No.	SIZE	RAILS	COUPLING	WEIGHT (pounds)
SRC300	62170806	3"	3/4", 1" or 1 1/4"	w/ upper guide bracket	71