



FINISH THOMPSON INC.

SF SERIES

SFS & SFS-H MODELS OPERATION & PARTS MANUAL

P/N 111522 R2





FINISH THOMPSON INC.

921 Greengarden Road • Erie, PA 16501-1591 U.S.A.
Ph 814-455-4478 • Fax 814-455-8518
Email fti@finishthompson.com • www.finishthompson.com

EU Declaration of Conformity



Finish Thompson Inc. hereby declares that the following machine(s) fully comply with the applicable health and safety requirements as specified by the EU Directives listed. The product may not be taken into service until it has been established that the drive motor for the centrifugal pump complies with the provisions of all relevant EU Directives. The complete product complies with the provisions of the EU Directive on machinery safety provided motors carry CE marking.

This declaration is valid provided that the devices are fully assembled and no modifications are made to these devices.

Type of Device:

Drum and Container Pump Tubes/Accessories

Models:

SFS27/40/48/54/60/72-ATEX, SFS27/40/48/54/60/72-ATEX-HT SFS27/40/48/54/60/72-H-ATEX,
SFS27/40/48/54/60/72-H-ATEX-HT
SFS/SFS-H-27/40/48/54/60/72
Nozzles (111030)

EU Directives:

Machinery Safety (2006/42/EC)

Applied Harmonized Standards:

EN ISO 12100:2010
EN 809:1998+A1:2009+AC:2010

Manufacturer: Finish Thompson Inc.
921 Greengarden Road
Erie, Pennsylvania 16501-1591 U.S.A

Signed,

Product Engineer

5 December 2022

Person(s) Authorized to Compile Technical File: Finish Thompson GmbH
Otto-Hahn-Strasse 16
Maintal, D-63477 DEU Telephone:
49 (0)6181-90878-0



FINISH THOMPSON INC.

921 Greengarden Road • Erie, PA 16501-1591 U.S.A.
Ph 814-455-4478 • Fax 814-455-8518
Email fti@finishthompson.com • www.finishthompson.com

Declaration of Conformity



Finish Thompson Inc. hereby declares that the following machine(s) fully comply with the applicable health and safety requirements as specified by the UKCA Directives listed. The product may not be taken into service until it has been established that the drive motor for the Drum and Container Pump complies with the provisions of all relevant UKCA Directives. The complete product complies with the provisions of the UKCA Directive on machinery safety provided motors manufactured by Finish Thompson Inc. are used.

This declaration is valid provided that the devices are fully assembled and no modifications are made to these devices.

Type of Device:

Drum and Container Pump Tubes/Accessories

Models:

SFS27/40/48/54/60/72-ATEX, SFS27/40/48/54/60/72-ATEX-HT SFS27/40/48/54/60/72-H-ATEX,
SFS27/40/48/54/60/72-H-ATEX-HT
SFS/SFS-H-27/40/48/54/60/72
Nozzles (111030)

UKCA Directives (and their applicable amendments):

The Supply of Machinery (Safety) Regulations 2008 (UKSI 2008 No. 1597)

Applied Designated Standards:

EN ISO 12100:2010
EN 809:1998+A1:2009+AC:2010

Manufacturer: Finish Thompson Inc.
921 Greengarden Road
Erie, Pennsylvania 16501-1591 U.S.A

Signed,

Product Engineer

31 May 2023

Introduction

This manual pertains to the SFS Series drum pumps and accessories. Finish Thompson Inc. thanks you for choosing our products. We believe the use of our products will be fully satisfactory. When properly installed and operated, your Finish Thompson motor and pump will provide long, trouble-free service; therefore, please read this manual carefully before carrying out any operations on the pump/motor unit. Any use other than that described herein is considered incorrect; and, consequently, Finish Thompson Inc. shall not be held responsible for any damages to people or property. In case of doubt or enquiries, please reply to our Technical Service department directly at the following address:

Finish Thompson, Inc.
921 Greengarden Rd.
Erie, PA 16501 U.S.A.
Tel. 1-814-455-4478; Fax 1-814-455-8518
www.finishthompson.com; fti@finishthompson.com

Index

Introduction	4
Warranty, General Terms & Conditions	5
Safety	6
Important Safety Information for Pumping Flammable or Hazardous Substances	7
Specifications & Dimensions	8
Operation	9
Disassembly	10-11
Reassembly	12-13
Exploded View – SFS Pump Tube	14
Pump Tube Spare Parts List	15-17
Troubleshooting	17

Note: Repair instructions can be downloaded from our web site at www.finishthompson.com or contact Technical Service at 1-800-888-3743 / email: techservice@finishthompson.com

Warranty, General Terms & Conditions

Finish Thompson, Inc (manufacturer) warrants this pump product to be free of defects in materials and workmanship for a period of **one year** from date of purchase by original purchaser. If a warranted defect, which is determined by manufacturer's inspection, occurs within this period, it will be repaired or replaced at the manufacturer's option, provided (1) the product is submitted with proof of purchase date and (2) transportation charges are prepaid to the manufacturer. Liability under this warranty is expressly limited to repairing or replacing the product or parts thereof and is in lieu of any other warranties, either expressed or implied. This warranty does not apply to normal wear of the product or components. This warranty does not apply to products or parts broken due to, in whole or in part, accident, overload, abuse, chemical attack, tampering, or alteration. The warranty does not apply to any other equipment used or purchased in combination with this product. The manufacturer accepts no responsibility for product damage or personal injuries sustained when the product is modified in any way. If this warranty does not apply, the purchaser shall bear all cost for labor, material and transportation.

Manufacturer shall not be liable for incidental or consequential damages including, but not limited to, process down time, transportation costs, costs associated with replacement or substitution products, labor costs, product installation or removal costs, or loss of profit. In any and all events, manufacturer's liability shall not exceed the purchase price of the product and/or accessories.

Warranty Registration

Thank you for your purchase of this quality Finish Thompson product. Be sure to take a minute to register your pump at Finishthompson.com/warranty. Simply provide the model number, serial number and a few other pieces of information.

Safety

1. Introduction

This manual contains all the information needed for the correct installation, use and maintenance of your new Finish Thompson pump and accessories. It should be read and understood by all the personnel involved in installation, operating and servicing of the pump before it is started.

2. Operator Qualification and Training

The personnel in charge of the installation, the operation, and the maintenance of the pump must be qualified and able to perform the operations described in this manual. Finish Thompson, Inc. shall not be held responsible for the training level of personnel and for the fact that they are not fully aware of the contents of this manual.

3. Safety Instructions

FOR YOUR OWN SAFETY

BEFORE using or servicing your pump or accessories, please make sure to wear the proper clothing, eye protection and follow standard safety procedures when handling corrosive or personally harmful materials.

GENERAL DANGER

While operating in a hazardous environment or pumping flammable or combustible materials:

ALWAYS use a conductive grounded discharge hose and grounding wire. The grounded discharge hose must comply with ISO 80079-36 and CLC/TR 60079-32-1, and must not exceed 10^6 ohms between each end. Certain fluid applications with the pump may lead to electrostatic discharges.

Ensure proper grounding and transferring methods are followed for the particular fluid.

ALWAYS use a Finish Thompson Haz Loc or ATEX motor rated for the hazardous environment.

NEVER use a plastic pump, plastic accessory, or an open, splash-proof, TEFC, non-Haz Loc, or non-ATEX motor when pumping or mixing flammable or combustible material.

ALWAYS ensure the pump, hose, and motor are bonded to ground, and the tanks/containers are separately bonded to ground.

ALWAYS inspect the integrity of the ground wire connections prior to each use.

ALWAYS ensure all components above the hose discharge of the pump (motor, bearing, coupling, etc) reside outside of the tank/container.

NEVER leave the pump unattended while in use.

NEVER run the pump dry without fluid.

NEVER run the pump with a closed valve (deadhead) for longer than 1 minute.

ALWAYS use and store the pump and motor in an upright position.

NEVER use in pressurized containers.

ALWAYS use a chemically compatible hose rated for the temperature of the product being pumped.

ALWAYS tighten and torque a stainless steel hose clamp to 25 in-lbs (2.8 N·m)

ALWAYS select the proper o-ring material. Improper material selection could lead to swelling and be a possible source of leaks. This is the responsibility of the end user.

ALWAYS check the pump for leaks on a regular basis. If leaks are noticed, the pump must be repaired or replaced immediately.

ALWAYS check compatibility and temperature range of pump with liquids used. A Chemical Resistance and Material Selection Guide can be downloaded from our website at www.finishthompson.com

NEVER use with liquids containing solids that can damage the internals (i.e. metal chips) without optional strainer.

ALWAYS store unit upright, i.e. motor above pump, and away from corrosive liquids and vapors.

ALWAYS check bearings and coupling insert for signs of overheating, abnormal noise or other signs of premature failure on a daily basis. Bearings and coupling insert should be replaced at the first sign of failure.

DANGER: POWER SUPPLY

Refer to instructions in the appropriate motor Operation & Installation Manual.

4. Noise Level

Refer to specifications in the appropriate motor Operation & Installation Manual.

5. Modifications and Spare Parts

Any changes concerning the service of the pump or accessory as originally purchased can be executed only after written approval from Finish Thompson Inc. It is recommended to use only genuine Finish Thompson Inc. spare parts and approved accessories. The use of non-original spare parts or non-approved accessories will void warranty and removes any responsibility on the manufacturer's behalf for any damage caused to people or things.

6. Cleaning

It is highly recommended to flush pumps and accessories with clean water or some other neutralizing fluid compatible with pump materials when done pumping or when switching chemicals.

IMPORTANT SAFETY INFORMATION FOR PUMPING FLAMMABLE OR HAZARDOUS SUBSTANCES

Read these instructions before operating the pump and motor equipment. The manufacturer will not be responsible for any damage to property or to persons caused by improper use of the equipment.

- ⚠ WARNING:** It is the responsibility of the user to operate the pump in conformance with OSHA rules for dispensing liquids. Pump containers should be grounded when using with flammable or combustible liquids to avoid static electricity.
1. Use only an explosion-proof rated electric or non-electric (air) motors on stainless steel pump tubes with a Static Protection Kit when transferring flammable or combustible liquids.
- ⚠ WARNING:** Never use an open, splash-proof, TEFC, battery-operated or non-explosion-proof rated motor or a plastic pump tube when transferring flammable or combustible liquids.
2. When operating a drum pump (especially when pumping flammable, combustible or hazardous liquids) follow all electrical and safety codes.
 - a) In the United States: the United States Occupational Safety and Health Act (OSHA), most recent National Electrical Code (NEC), National Fire Protection, Inc. (NFPA) Code 30 (Flammable and Combustible Code), NFPA 77 (Static Electricity), NFPA 251 (Standard Method of fire Test of Building Construction), NFPA 704 (Identification of the Fire Hazards of Materials), and other NFPA codes, local codes and ordinances.
 - b) Outside the United States: the ATEX equipment directive 2014/34/EU where applicable, the ATEX workplace 99/92/EC directive where applicable, in addition the precautions of the U.S. codes listed herein and all other local codes and ordinances.
 3. Pumping hazardous, flammable, or combustible liquids should only be done in buildings, rooms, or areas suited for this purpose. (See NFPA 30, NFPA 78, NFPA 80, NFPA 251, NFPA 704, other suitable NFPA codes, OSHA, ATEX workplace 99/92/EC directive insurance companies, and other local codes and ordinances.)
 4. When filling cans, drums, etc. with combustible or flammable liquids, both container pumping from and container pumping to, should be bonded and grounded to dissipate possible accumulations of static electricity, and minimize sparks caused by static electricity (refer to NFPA 77 and CLC/TR 60079-32-1 for specific details).
- ⚠ WARNING:** Avoid splashing. Splash filling can create static electricity and is extremely hazardous. Reduce motor speed to prevent splashing.
- ⚠ WARNING:** Fluid velocity must be 3 feet/.9 meter/second maximum (7 gpm/26.5 lpm in 1" hose and 4 gpm/15 lpm in ¾" hose) to reduce risk of static electricity. Reduce motor speed to reduce the fluid velocity.
5. Before using, confirm that the pump and any accessories (hose, nozzle, flow meter, etc.) materials of construction are suitable for the material to be pumped and that the maximum temperature is not exceeded.

INFORMATIONS IMPORTANTES SUR LA SÉCURITÉ DURANT LE POMPAGE DE SUBSTANCES INFLAMMABLES OU DANGEREUSES

Veillez lire attentivement ces instructions avant d'utiliser la pompe et l'équipement du moteur. Le fabricant ne sera pas tenu responsable des dommages matériels ou corporels causés par une utilisation inappropriée de l'équipement.

- ⚠ AVERTISSEMENT:** Il est de la responsabilité de l'utilisateur de faire fonctionner la pompe conformément aux règles OSHA (Santé et Sécurité au Travail) relatives à la distribution de liquides. Les conteneurs de pompes doivent être électriquement mis à la terre lors de l'utilisation de liquides inflammables ou combustibles afin d'éviter toute électricité statique.
1. Lors du transfert de liquides inflammables ou combustibles, utilisez uniquement des moteurs électriques ou non électriques (pneumatiques) antidéflagrants sur des tubes de pompe en acier inoxydable dotés d'un dispositif de protection antistatique.
- ⚠ AVERTISSEMENT:** N'utilisez jamais de moteur ouvert, à l'épreuve des éclaboussures, TEFC, alimenté par piles ou non antidéflagrant, ni un tube de pompe en plastique lors du transfert de liquides inflammables ou combustibles.
2. Lors de l'utilisation d'une pompe à tambour (en particulier lors du pompage de liquides inflammables, combustibles ou dangereux), respectez tous les codes électriques et les codes de sécurité.
 - a) Aux États-Unis : Loi américaine sur la sécurité et la santé au travail (OSHA); le code national de l'électricité (NEC) le plus récent; le code 30 de la NFPA (code d'inflammabilité et de produits combustibles); le code NFPA 77 (électricité statique); le code NFPA 251 (Méthode standard de test d'incendie de la construction de bâtiments); le code NFPA 704 (Identification des risques d'incendie des matériaux) et autres codes et règlements de la NFPA.
 - b) En dehors des États-Unis : La directive sur les équipements ATEX 2014/34 / EU, le cas échéant, la directive ATEX sur le lieu de travail 99/92 / EC, le cas échéant, ainsi que les précautions des codes des États-Unis énumérés dans la présente et de tous les autres codes, lois et règlements locaux.
 3. Le pompage de liquides dangereux, inflammables ou combustibles ne doit être effectué que dans des bâtiments, des pièces ou des zones adaptées à cet usage. (Voir NFPA 30, NFPA 78, NFPA 80, NFPA 251, NFPA 704, autres codes NFPA appropriés, OSHA, les directives des compagnies d'assurance ATEX 99/92 / CE, et autres codes, lois et règlements locaux.)
 4. Lors du remplissage de bidons, fûts, etc. avec des liquides combustibles ou inflammables, les conteneurs d'où le liquide est pompé et le conteneur recevant le liquide doivent être reliés et mis à la terre pour éviter toute accumulation éventuelle d'électricité statique et minimiser ainsi les étincelles causées par l'électricité statique (voir NFPA 77). et CLC / TR 60079-32-1 pour des détails spécifiques).
- ⚠ AVERTISSEMENT:** Évitez les éclaboussures. Les éclaboussures peuvent créer de l'électricité statique et sont extrêmement dangereuses. Réduisez la vitesse du moteur pour éviter les éclaboussures.
- ⚠ AVERTISSEMENT:** La vitesse du fluide doit être au maximum de 3 pieds / 0,9 mètre / seconde (7 gpm / 26,5 lpm dans un tuyau de 1"; et 4 gpm / 15 lpm dans un tuyau de ¾") afin de réduire le risque d'électricité statique. Réduisez la vitesse du moteur afin de réduire ainsi la vitesse du fluide.
5. Avant utilisation, assurez-vous que les matériaux de la pompe et des accessoires (tuyau, ajustage, débitmètre, etc.) sont compatibles avec le fluide et que la température maximale n'est pas dépassée.

PUMP SPECIFICATIONS				
Impeller Type	High Flow (standard offering) or High Head "-H"			
Discharge Spout	1" (DN 25 (25MM)) Barb (standard)	1" BSPP Thread (Model -BSP)	1" NPT Thread (Model -MT)	1" Tri-Clamp Fitting (Model -TC)
Discharge Attachment Thread	1-1/4" BSPP			
Outer Tube Diameter	1-5/8" (41mm)			
Max. Specific Gravity	2.0			
Max. Viscosity	1200 cP			
Min./ Max. Fluid Temperature	5°F (-15°C) Min.			
	212°F (100°C) Max.			
Wetted Pump Components	316SS, PTFE, ETFE			
Wetted O-rings	Option of: FKM, FFKM, FDA FFKM or FDA Buna			

MODEL	DIM A	DIM B
SFS27	26 7/8" (683mm)	28 7/16" (722mm)
SFS40	39 7/8" (1013mm)	41 7/16" (1053mm)
SFS48	47 7/8" (1216mm)	49 7/16" (1256mm)
SFS54	53 7/8" (1368mm)	55 7/16" (1408mm)
SFS60	59 7/16" (1510mm)	61 1/16" (1551mm)
SFS72	72 9/16" (1843mm)	74 1/8" (1883mm)

MV MOTORS

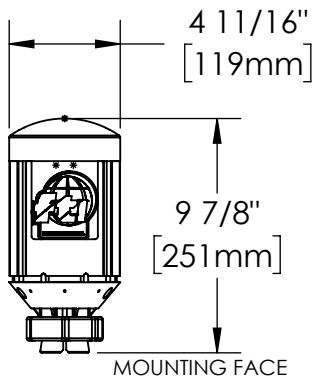

M6 & M6A AIR MOTORS

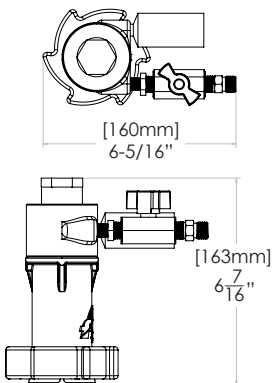

TEFC & EXP MOTORS

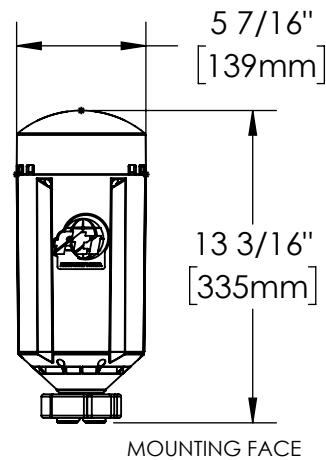

MV MOTOR SHOWN ON PUMP

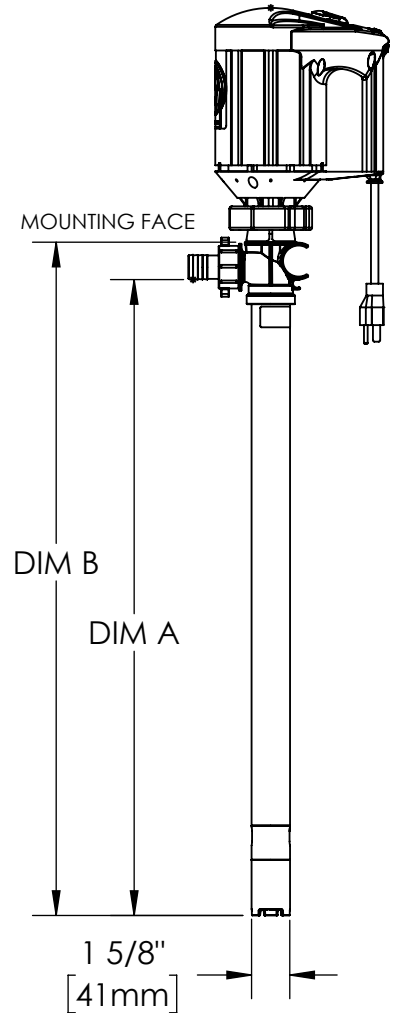

OPERATION

1. Make sure the motor (electric or air) is properly installed on the pump tube and is in the off position. See motor instruction manual for installation instructions.
2. Insert the pump tube into the fluid to be dispensed and the hose into the container to be filled prior to starting the pump. Bung adapters are available to provide a tighter fit between the pump tube and bung opening of a standard drum. Check drum pump accessories at www.finishthompson.com or contact your local Finish Thompson distributor for bung adapter info.
3. Make sure the pump's discharge hose is properly secured before operating the motor, torque Finish Thompson hose clamps to 25 in-lbs (2.8 N·m).
4. Begin pumping by turning the motor on and verifying that there are no leaks. If leaks are noticed immediately turn the motor off and check all discharge hose connections.

NEVER allow the pump to run dry.

NEVER pump liquids containing solids that can damage internal pump parts (i.e. metal chips). Pumping solids can lead to increased wear.

Typical Grounding Example For Flammables

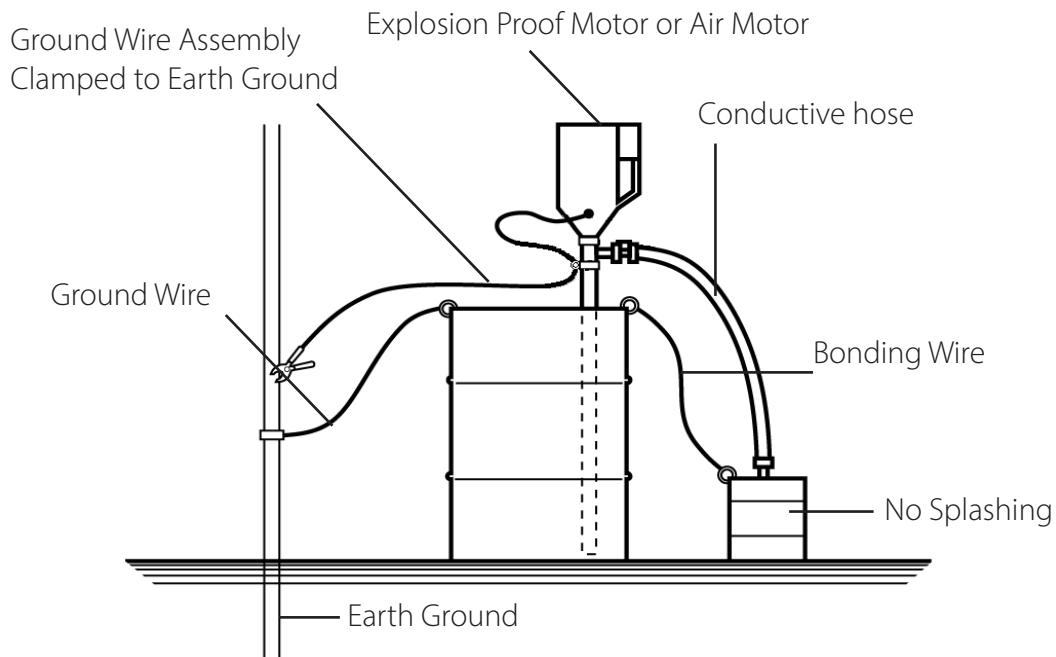

Hose & Cord Storage

SF model pumps have a built-in hose & cord clip. You can use these clips to store your hose and keep the plug off the floor, free of damage and corrosion. When selecting a discharge hose, you should use a 1" ID reinforced chemically compatible hose secured with a stainless steel hose clamp. See figures A and B below.



Figure A



Figure B

Choice of two types of Impellers

The SFS-Series pump models can be ordered with either a "High Flow" or "High Head" impeller. The high flow impeller utilizes an axial design impeller and built in strainer/diffuser cover for quickly dispensing fluids from drums & totes. The high head impeller utilizes a centrifugal design impeller to produce high head for dispensing through long hose runs or to overcome high system pressures. Either impeller can be used with the same pump but it is important to use the correct diffuser cover to attain the proper performance. See figures shown.

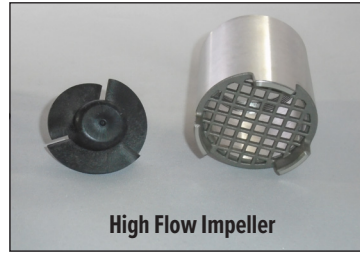

DISASSEMBLY & REASSEMBLY INSTRUCTIONS

Disassembly

- Cover, Impeller, & Diffuser Removal** - Unthread the diffuser cover (item 22 or 23). Turn it clockwise (left-hand thread). See Figure 1 A & B. Unthread the impeller (item 20 or 21) turning it counter clockwise (right hand thread) using your hand while holding the coupling insert and coupling (items 1 & 2) with the other hand. See Figure 2 A & B. Note: If the shaft unthreads from the coupling, use a pliers to hold the bottom of the shaft just above the impeller. See figures 3 A & B. For longer 40" to 72" pump lengths, two people may be required to hold the shaft and unthread the impeller.
- Shaft Removal** - To remove the shaft (item 4), tap the bottom of the shaft on a piece of wood or plastic and push the shaft up and out of the head (item 6). See Figure 4 A & B. Grab the half coupling or bearing and pull the shaft assembly straight out of the head. Note: Take care to not bend the shaft.

Important - The shaft should only be removed if the bearing is frozen and needs to be replaced. Hold the pump shaft (item 4) with a pliers or vise grip. Turn the half coupling (item 2) counter clockwise (right hand thread) to remove it from the shaft. The bearing (item 3) will slide off the shaft. See Figure 5 A, B, and C. If the bearing is frozen or corroded to the shaft use a penetrating fluid and socket to help tap it off. Install a new bearing (item 3), reuse and hand tighten the half coupling (item 2). These items will only fit properly on one end of the shaft.

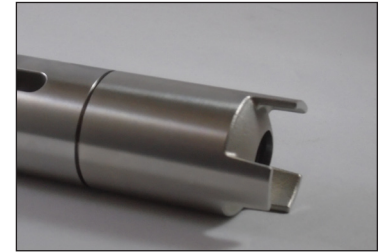
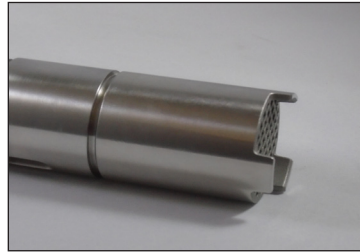

Figure 1 A & B

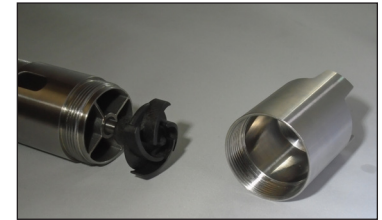

Figure 2 A & B

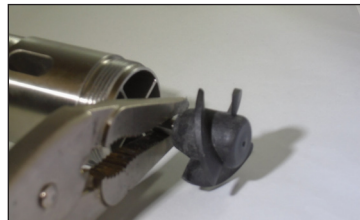
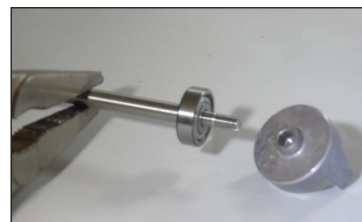

Figure 3 A & B



Figure 4 A & B

Figure 5 A, B, C



Disassembly Continued

3. **Intake Tube Removal** - Unthread the diffuser (item 18) turning it clockwise (left-hand thread). The shaft sleeve (item 15) will drop out of the inner tube by holding it in a vertical position. Remove the intake tube (item 16). Hold the head (item 6) in one hand and with the other hand, turn the intake tube clockwise (left-hand thread). When completely unthreaded, pull the intake tube away from the head exposing the inner tube (item 14) See Figure 6 A, B, C, D, & E.
4. **Inner Tube Removal** - To remove the inner tube, turn the inner tube to unseat the o-rings (item 13) and then pull the inner tube away from the head. See Figure 7 A & B.
5. **Outer Tube O-ring Replacement** - If the o-ring (item 12) needs replaced use an o-ring pick to pull it out of the pump head (item 6). See Figure 8 A, B & C.
6. **Seal Removal** - To remove the seal (item 5) from the head (item 6), use a hook tool, available at most hardware stores, to pull the seal out from the top of the head. Take care not to damage the seal seat area. See Figures 9 A & B. Note: The seal should be replaced if worn or the bearing is failing or frozen.

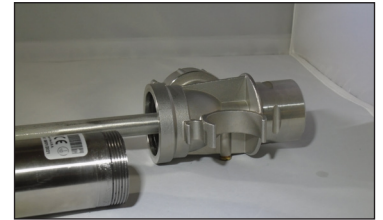
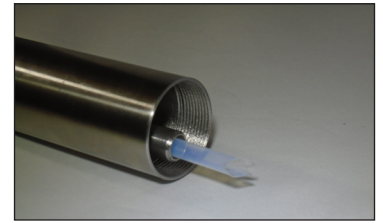
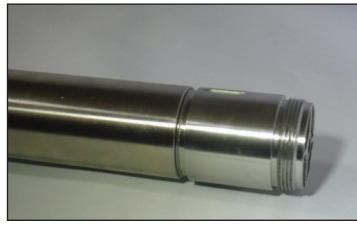

Figure 6 A, B, C, D, & E

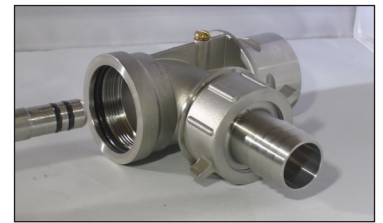
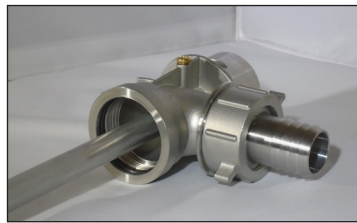

Figure 7 A & B

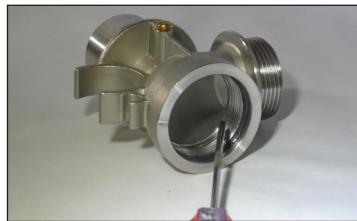

Figure 8 A, B, & C



Figure 9 A & B

Reassembly

- 1. Seal Installation** - Take the head (item 6), and install a new seal (item 5). It is recommended to lubricate the seal with a compatible lubricant or water prior to pressing it in. Insert the open part of the seal into the lower bore of the head. Use a 7/16" (12 mm) dowel to press and seat the seal into place. Seal sits slightly below the surface. See figures 10 A, B, C & D. If the outer tube o-ring (item 12) was removed, replace it before installing the outer tube. A compatible lubricant or Vaseline can be used to help the tube slide up into place to engage the threads. Note:
never reuse an old lip seal.



Figure 10 A, B, C & D

- 2. Inner Tube Installation** - Reinstall the inner tube (item 14). The double o-ring side seats up into the head with a slight twisting motion. Make sure the inner tube is seated properly. It is recommended to use a compatible lubricant or water on the o-rings. See figures 11 A & B.



Figure 11 A & B

- 3. Intake Tube Installation** - Install the intake tube (item 16). Slide the intake tube with external threads over the inner tube up into the head (item 6). While pushing the intake tube's threads beyond the o-ring, turn the intake tube counter clockwise (left hand thread) to tighten it into the head. Ensure the threads do not start to cross-thread. Hand tighten. The bottom of the inner tube will be recessed slightly with the bottom of the outer tube when properly seated. See figures 12 A, B & C.



Figure 12 A, B, & C

- 4. Reinstall** the half coupling, bearing and shaft (items 2, 3, & 4 indicated on the Exploded View Drawing) as an assembly into the head. If the bearing needs to be replaced see section 2 of the disassembly instructions on the prior page. See figures 13 A & B.



Figure 13 A & B

Reassembly Continued

5. **Shaft Installation** - Slide the shaft down through the seal until the bearing engages the bearing bore in the head. Set the half coupling on the floor and push the pump down using the intake tube (item 16) for leverage. Make sure the bearing (item 3) is flush with the top of the head (item 6). While the pump is in this upright position slide the shaft sleeve (item 15) between the shaft (item 4) and inner tube (item 14). The shaft sleeve is self positioning so just push it in all the way completely into the inner tube. Sleeve is flared on the bottom to help hold it in position. See figures 14 A, B, C, D.

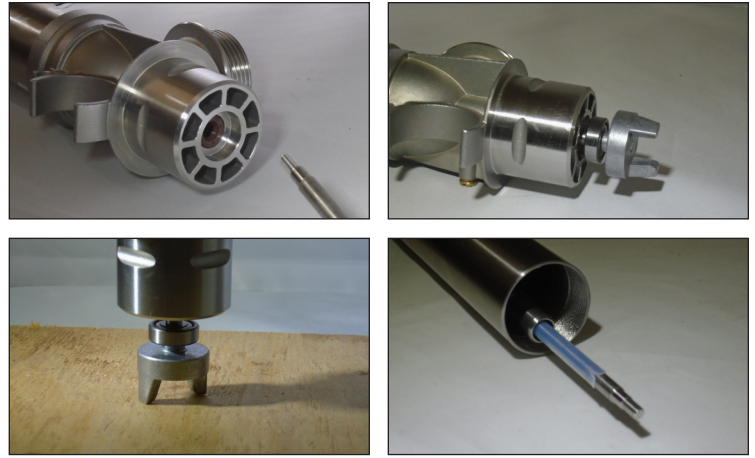

Figure 14 A, B, C, D

6. **Diffuser Installation** - Install the diffuser (item 8) onto the bottom of the outer tube. This is a tight fit so it is recommended to use a compatible lubricant or water. Insert the shaft through the small support opening on the diffuser. The small support opening will insert up inside the inner tube (item 12). With a slight push and turn, thread the diffuser into the outer tube (item 6) turning counter clockwise (left hand thread). Thread the diffuser (item 6) completely onto the bottom of the outer tube (item 5). Hand tighten. See figures 15 A, B, & C.

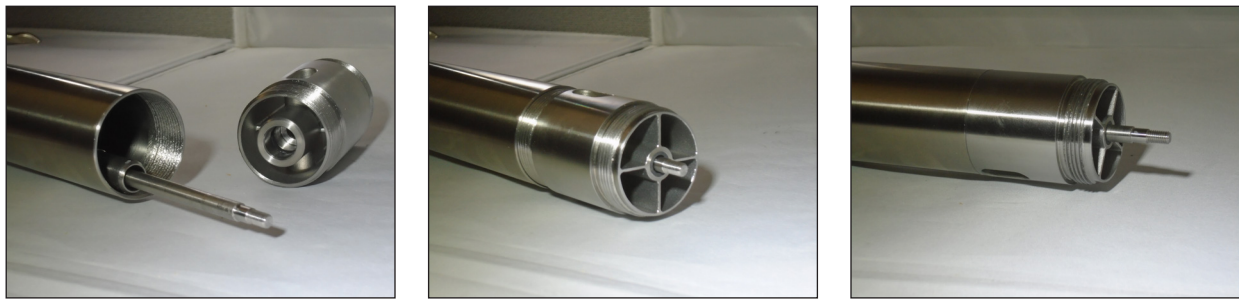

Figure 15 A, B, & C

7. Thread the impeller (items 20 or 21) onto the shaft by hand. While holding the half coupling with the other hand, turn the impeller clockwise (right hand thread). Install the diffuser cover (item 22 or 23) onto the diffuser turning counter clockwise (left hand thread). Hand Tighten. See Figures 16 A, B, C, D, E, F, & G.



Figure 16 A, B, C, D, E, F, & G

**SFS SERIES PUMP
EXPLODED VIEW**

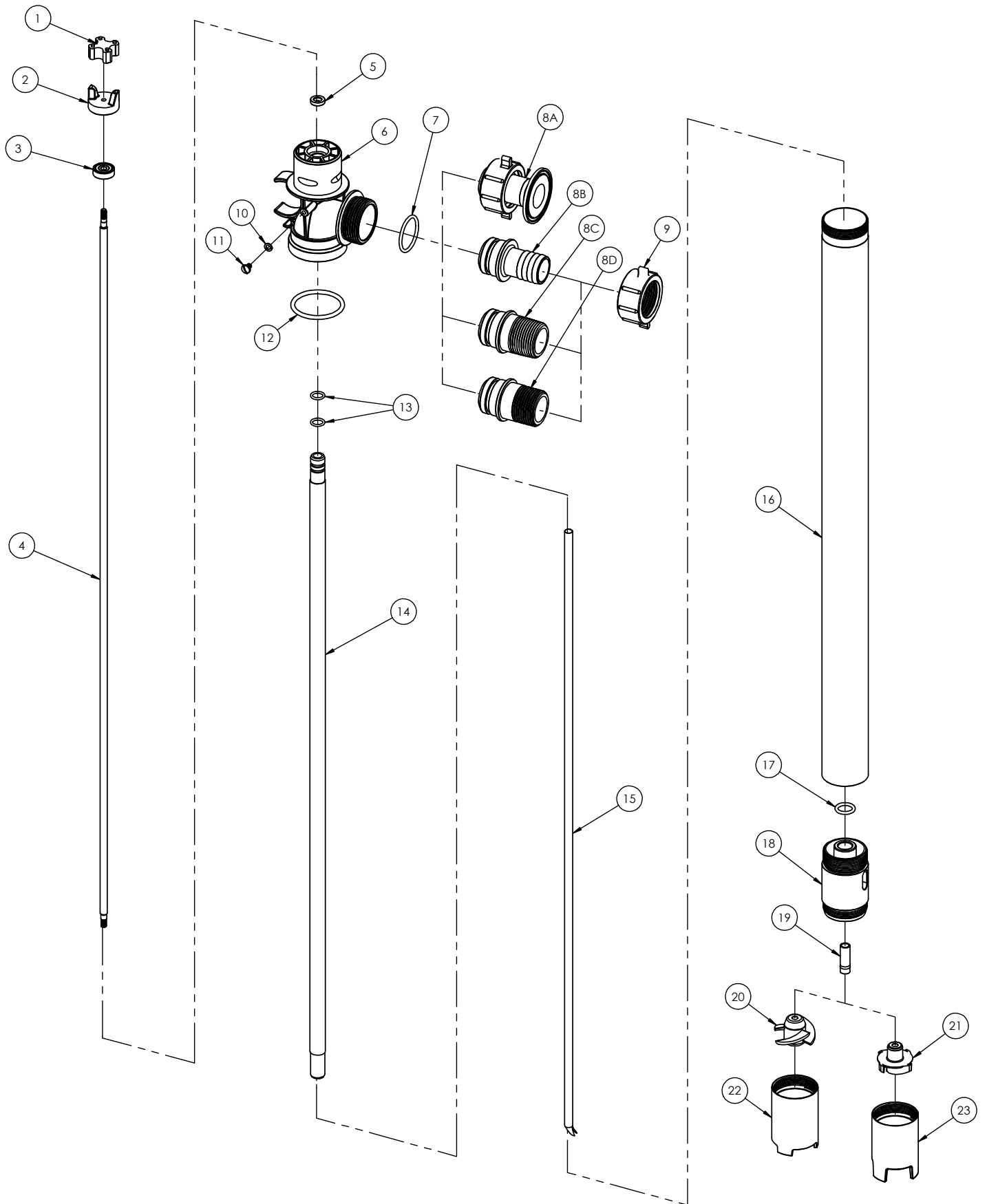

PUMP SPARE PARTS LIST

ITEM	QTY	DESCRIPTION	PART NUMBER	
			MODEL SFS	MODEL SFS-H
1*	1	COUPLING INSERT		
		RUBBER		J100014
2	1	COUPLING HALF		
		ALUMINUM		111530
3*	1	BEARING		
		STEEL		111057
4	1	SHAFT (316 STAINLESS STEEL)		
		27"		111202-1
		40"		111202-3
		48"		111202-5
		54"		111202-7
		60"		111202-9
		72"		111202-11
5*	1	SEAL		
		FKM (STANDARD)		107592
		PTFE (-FF or -P MODELS)		107622
6	1	HEAD		
		316 STAINLESS STEEL		111500
7*	1	O-RING, DISCHARGE SPOUT		
		FKM (STANDARD)		109526
		FFKM (-FF MODELS)		111501
		FDA FFKM (-P MODELS)		111502
		FDA BUNA (-B MODELS)		111503
		DISCHARGE SPOUT (316 STAINLESS STEEL)		
8A	1	1" TRI-CLAMP (INCLUDES NUT) (-TC MODELS)		111505
8B		1" BARB (DN 25) (STANDARD)		111506
8C		1" NPT (-MT MODELS)		111507
8D		1" BSPP (-BSP MODELS)		111521
9	1	NUT		
		316 STAINLESS STEEL		111508
10	1	LOCK WASHER		
		#8 BRASS		J100823
11	1	SCREW		
		#8-32 x 1/4 BRASS PAN HEAD		J100822
12*	1	O-RING, OUTER TUBE		
		FKM (STANDARD)		105080
		FFKM (-FF MODELS)		111509
		FDA FFKM (-P MODELS)		111510
		FDA BUNA (-B MODELS)		108069

PUMP SPARE PARTS LIST

ITEM	QTY	DESCRIPTION	PART NUMBER		
			MODEL SFS	MODEL SFS-H	
13*	2	O-RING, INNER TUBE			
		FKM (STANDARD)		J100018	
		FFKM (-FF MODELS)		111511	
		FDA FFKM (-P MODELS)		105620	
		FDA BUNA (-B MODELS)		108197	
14	1	INNER TUBE (316 STAINLESS STEEL)			
		27"		107616-1	
		40"		107616-2	
		48"		107616-3	
		54"		107616-7	
		60"		111512-1	
		72"		111512-2	
15*	1	SHAFT SLEEVE (PTFE)			
		27"		111513-1	
		40"		111513-2	
		48"		111513-3	
		54"		111513-7	
		60"		111529-5	
		72"		111529-6	
16	1	OUTER TUBE (316 STAINLESS STEEL)			
		27"		111515-1	
		40"		111515-2	
		48"		111515-3	
		54"		111515-4	
		60"		111515-5	
		72"		111515-6	
		27" ELECTROPOLISHED (-P OR -B MODELS)		111532-1	
		40" ELECTROPOLISHED (-P OR -B MODELS)		111532-2	
		48" ELECTROPOLISHED (-P OR -B MODELS)		111532-3	
		54" ELECTROPOLISHED (-P OR -B MODELS)		111532-4	
17*	1	O-RING, DIFFUSER			
		FKM (STANDARD)		J100132	
		FFKM (-FF MODELS)		111516	
		FDA FFKM (-P MODELS)		107621	
		FDA BUNA (-B MODELS)		108198	
18	1	DIFFUSER			
		316 STAINLESS STEEL		111517	
19*	1	BUSHING, DIFFUSER			
		PTFE (STANDARD)		111518-1	
		FDA PTFE (-P OR -B MODELS)		111518-2	
20*	1	IMPELLER - HIGH FLOW (FOR USE WITH "DIFFUSER COVER - HIGH FLOW")			
		CFF ETFE (STANDARD)	111210-3		N/A
		PURE ETFE (FOR MODELS ENDING IN -P OR -B)	111210-2		N/A

PUMP SPARE PARTS LIST

ITEM	QTY	DESCRIPTION	PART NUMBER	
			MODEL SFM	
21*	1	IMPELLER - HIGH HEAD (FOR USE WITH "DIFFUSER COVER - HIGH HEAD")		
		CFF ETFE (STANDARD)	N/A	111211-3
		PURE ETFE (FOR MODELS ENDING IN -P OR -B)	N/A	111211-2
22*	1	DIFFUSER COVER - HIGH FLOW		
		316 STAINLESS STEEL	111519	N/A
23*	1	DIFFUSER COVER - HIGH HEAD		
		316 STAINLESS STEEL	N/A	111520

*Recommended spare parts

DRUM PUMP TROUBLESHOOTING

General Notes:

- Do not pump liquids containing metallic particles or other foreign material.
- Always store the pump upright as used.
- Contact our Technical Service Department at 1-800-888-3743 or by email at techservice@finishthompson.com if you have any questions regarding product operation or repair.

No or Insufficient Discharge:

- Closed valve or nozzle
- System head higher than anticipated
- Viscosity or specific gravity too high
- Clogged pump tube
- Clogged or damaged impeller

Vibration/Noise:

- Missing or damaged coupling insert
- Damaged bearing assembly
- Viscosity or specific gravity too high
- Pump cavitation from improper discharge
- Pump or piping not properly secured
- Clogged or damaged impeller



FINISH THOMPSON INC.

921 Greengarden Road • Erie, PA 16501-1591 U.S.A.
 Ph 814-455-4478 • Fax 814-455-8518
 Email fti@finishthompson.com • www.finishthompson.com

Service 1-800-888-3743
 P/N 111522 R2
 10/20/2023