



## FEATURES

**Impeller:** Cast iron, semi-open or enclosed, non-clog, dynamically balanced with pump out vanes for mechanical seal protection. Optional silicon bronze impeller available.

**Casing:** Cast iron flanged volute type for maximum efficiency. Designed for easy installation on A10-20 guide rail.

### Dual Mechanical Seals

- **Lower:** SILICON CARBIDE VS. SILICON CARBIDE sealing faces for superior abrasive resistance, stainless steel metal parts, BUNA-N elastomers.
- **Upper:** CARBON VS. CERAMIC sealing faces, stainless steel metal parts, BUNA-N elastomers.

**Seal Sensor Probe:** Located in oil-filled chamber. If pumpage should begin to leak past lower seal it indicates to pump control panel a fault has occurred. Requires optional Seal Fail Circuit in the control panel.

**Shaft:** Corrosion resistant, 400 stainless steel. Threaded design. Locknut on all models to guard against component damage on accidental reverse rotation.

**Fasteners:** 300 series stainless steel.

Capable of running dry without damage to components.

Designed for continuous operation when fully submerged.

## AGENCY LISTINGS



Tested to UL 778 and CSA 22.2 108 Standards  
By Canadian Standards Association  
File #LR38549

# 2WD/3WD 50 Hz

SUBMERSIBLE 2" NON-CLOG SEWAGE PUMP

DUAL SEAL WITH SEAL SENSOR PROBE

### APPLICATIONS

Specifically designed for the following uses:

- Sewage systems
- Dewatering/Effluent
- Water transfer
- Light industrial
- Commercial applications

Anywhere waste or drainage must be disposed of quickly, quietly and efficiently.

### SPECIFICATIONS

#### Pump:

- Solids handling capabilities: 2" maximum
- Capacities: up to 183 GPM
- Total heads: up to 52' TDH
- Discharge size: 2" NPT threaded companion flange on 2WD. 3" NPT threaded companion flange on 3WD.
- Temperature:
  - 104° F (40° C) continuous,
  - 140° F (60° C) intermittent.

### MOTORS

- Fully submerged in high grade turbine oil for lubrication and efficient heat transfer. All ratings are within the working limits of the motor.
- Class F insulation
  - Three phase (50 Hz):
    - Overload protection must be provided in starter unit.
    - ½-1 HP - 14/4 STOW with bare leads.
- Designed for Continuous Operation: Pump ratings are within the motor manufacturer's recommended working limits, can be operated continuously without damage when fully submerged.
- Bearings: Upper and lower heavy duty ball bearing construction.
- Power and Control Cable: Severe duty rated, oil and water resistant. Epoxy seal on motor end provides secondary moisture barrier in case of outer jacket damage and to prevent oil wicking. 20 foot standard with optional lengths available.

### NOMENCLATURE DESCRIPTION

#### 1st Character - Discharge Size

2 = 2" discharge     3 = 3" discharge

#### 2nd and 3rd Characters - Series/Solids Size

WD = wastewater, 2" solids handling, dual seal with seal fail probe in pump.

#### 4th Character - Mechanical Seals

5 = silicon carbide/silicon carbide/BUNA - lower seal and carbon/ceramic/BUNA - upper seal (standard)

3 = silicon carbide/tungsten carbide/BUNA - lower seal and carbon/ceramic/BUNA - upper seal (optional)

#### 5th Character - Cycle/RPM

5 = 50 Hz/2900 RPM  
6 = 50 Hz/1450 RPM

#### 6th Character - Horsepower

B = 1/3 HP                      D = 3/4 HP  
C = 1/2 HP                      E = 1 HP

#### 7th Character - Phase/Voltage/Enclosure

6 = three phase, 380 V

#### 8th Character - Impeller Diameter

A = 3.69"                      H = 3.44"  
B = 5.75"                      J = 3.19"  
C = 5.38"                      G = 4"  
D = 5.00"

#### 9th Character - Cord Length (Power and Sensor)

A = 20' (standard)        F = 50'  
D = 30'                      G = 100'

#### 10th Character - Options

B = Bronze impeller     E = Epoxy paint  
F = Both epoxy paint and bronze impeller

#### Last Character - Option

H = Pilot duty thermal sensors

### MODELS AND MOTOR INFORMATION

Order Number	HP	Phase	Volts	RPM	Impeller Dia. (in.)	Impeller Code	Maximum Amps	Locked Rotor Amps	KVA Code	Resistance Start	Weight (lbs.)
2WD55B6JA	1/3	3	380	2900	3.19	J	1.7	4.9	K	39.4	94
2WD55C6HA	1/2				3.44	H	1.8	8.9	J	22.4	94
2WD55D6AA	3/4				3.69	A	2.9	8.9	J	22.4	98
2WD55E6GA	1				4	G	3.3	18	J	22.4	98
2WD56B6DA	1/3			1450	5	D	1.8	9.4	R	23.2	94
2WD56C6CA	1/2				5.38	C	2.7	7.9	K	34.2	98
2WD56D6BA	3/4				5.75	B	3.8	12.1	L	16.2	98

### MATERIALS OF CONSTRUCTION

Item No.	Part Name	Material				
		Standard	Optional			
1	Impeller	1003	1179			
2	Motor Cover	1003				
3	Shaft	400 Series SS				
4	Fasteners	300 Series SS				
5	Ball bearings	Steel				
6	Power cable	STOW, 20 feet	Additional lengths			
	Seal sensor cable					
7	O-ring	BUNA-N				
8	<b>Outer Mech. Seal</b>	<b>Service</b>	<b>Rotary</b>	<b>Stationary</b>	<b>Elasto-mers</b>	<b>Metal Parts</b>
	OPT	Heavy duty	Silicon Carbide	Tungsten Carbide	BUNA-N	300 Series SS
	STD	Mild abrasives	Silicon Carbide		BUNA-N	300 Series SS
<b>Material Code</b>		<b>Engineering Standard</b>				
1003		Cast iron – ASTM A48 Class 30				
1179		Silicon bronze – ASTM C87600				

### DIMENSIONS

(All dimensions are in inches. Do not use for construction purposes.)

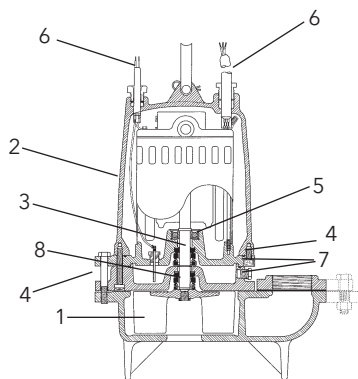
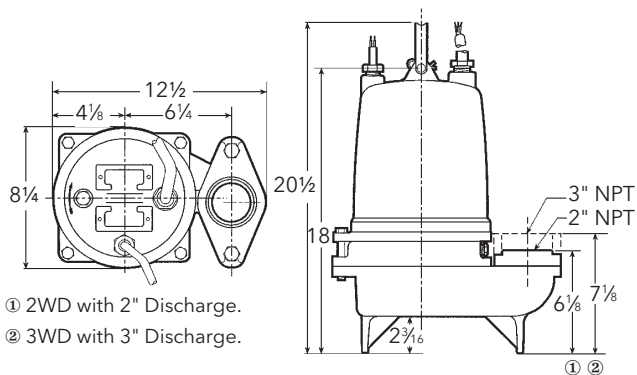

## APPLICATION DATA

Maximum Solid Size	2"
Minimum Casing Thickness	5/16"
Casing Corrosion Allowance	1/8"
Maximum Working Pressure	22 PSI
Maximum Submergence	50 feet
Minimum Submergence	Fully submerged for continuous operation
	6" below top of motor for intermittent operation
Maximum Environmental Temperature	40°C (104°F) continuous operation
	60°C (140°F) intermittent operation

## CONSTRUCTION DETAILS

Power Cable - Type	14/4, type STOW: all three phase
Sensor Cable - Type	16/2, type SJTOW: seal sensor only
	18/4, type SJTOW: optional seal/heat sensor
Motor Cover	Gray Cast Iron - ASTM A48 Class 30
Bearing Housing	Gray Cast Iron - ASTM A48 Class 30
Seal Housing	Gray Cast Iron - ASTM A48 Class 30
Casing	Gray Cast Iron - ASTM A48 Class 30
Impeller	Gray Cast Iron - ASTM A48 or Cast Bronze - ASTM B584 C87600
Motor Shaft	AISI 400 Series Stainless Steel
Motor Design	NEMA 48 Frame, oil filled with Class F Insulation
Motor Overload Protection	Three Phase: require ambient compensated Class 10, quick trip overloads in the control panel.
Motor Seal Fail (Moisture) Detection	Seal fail sensor in an oil-filled seal chamber. Connect to an optional relay in control panel.
Optional Motor Thermal Protection	Normally closed on-winding thermostats open at 275° F (135 °C) and close at 112° F (78° C). Require terminal connection in the control panel.
External Hardware	300 Series Stainless Steel
Impeller Type	Semi-opened with pump out vanes on back shroud - 1750 RPM
	Enclosed with pump out vanes on back shroud - 3500 RPM
Oil Capacity - Seal Chamber	10 ounces
Oil Capacity - Motor Chamber	4.0 quarts

## STANDARD PARTS

Ball Bearing	Upper	Single row ball - SKF™ 6203-2Z
	Lower	Single row ball - SKF™ 6203-2Z
Mechanical Seals - Standard	Upper	Carbon/Ceramic; John Crane Type 6
	Lower	Silicon Carbon/Silicon Carbon; Type 16
Mechanical Seals - Optional Lower		Silicon Carbide/Tungsten Carbide: Type 16
O-Ring - Stuffing Box		BUNA-N, AS 568A-163
O-Ring - Motor Cover		BUNA-N, AS 568A-166



Xylem, Inc.  
2881 East Bayard Street Ext., Suite A  
Seneca Falls, NY 13148  
Phone: (866) 325-4210  
Fax: (888) 322-5877  
[www.xylem.com/brands/gouldswatertechnology](http://www.xylem.com/brands/gouldswatertechnology)

Goulds is a registered trademark of Goulds Pumps, Inc. and is used under license.  
© 2012 Xylem Inc. B23WD50HZ March 2011