

EOM

ENGINEERING OPERATION
& MAINTENANCE

T8 Clamped Metal Pump



Where Innovation Flows

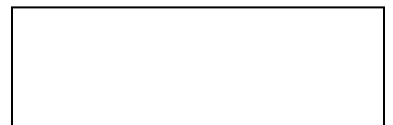

Contents

Section 1: Precautions - Read First!	4
Section 2: Wilden Pump Designation System	5
Section 3: How It Works	6
Section 4: Dimensional Drawings	7
Section 5: Performance	9
T8 Metal Rubber-Fitted.....	9
T8 Metal TPE-Fitted.....	9
T8 PTFE-Fitted.....	10
T8 Stallion Ultra-Flex™-Fitted.....	10
T8 Metal Stallion TPE -Fitted.....	11
Suction-Lift Capability.....	12
Section 6: Suggested Installation, Operation, Maintenance and Troubleshooting.	13
Section 7: Disassembly / Reassembly	16
Pump Disassembly.....	16
Air Valve Disassembly.....	19
Gasket Kit Installation.....	22
Section 8: Exploded View and Parts List	23
T8 Metal Rubber/TPE-Fitted.....	23
T8 Metal PTFE-Fitted.....	27
Section 9: Elastomer Options	29

Copyright

Copyright 2018 PSG®, a Dover Company. All rights reserved.

PSG reserves the right to modify the information and illustrations in this document without prior notice. The product described in this document is furnished under a license agreement or nondisclosure agreement. No part of this document may be reproduced, stored in a retrieval system, or transmitted in any form or any means electronic or mechanical, including photocopying and recording, without the written permission of PSG, a Dover Company, except as described by the terms of those agreements.

This is a non-contractual document. 01-2019.

Trademarks

PSG and the PSG logo are registered trademarks of PSG. Wilden® is a registered trademark of PSG California LLC. Pro-Flo® SHIFT and Pro-Flo® are registered trademarks of PSG California LLC. Wil-Flex® is a trademark of PSG California LLC. Saniflex™ is a trademark of PSG California LLC.

All trademarks, names, logos and service marks (collectively "trademarks") in this document are registered and unregistered trademarks of their respective owners. Nothing contained in this document should be construed as granting any license or right to use any trademark without the prior written permission of the trademark owner.

Warranty

Each and every product manufactured by Wilden is built to meet the highest standards of quality. Every pump is functionally tested to insure integrity of operation. Wilden warrants that pumps, accessories and parts manufactured or supplied by it to be free from defects in material and workmanship for a period of five (5) years from date of installation or six (6) years from date of manufacture, whichever comes first.

For more information, and to register your Wilden pump for warranty, please visit <https://www.psgdover.com/wilden/support/warranty-registration>.

Certifications

Section 1

Precautions - Read First!



TEMPERATURE LIMITS:

Nylon	-17.8°C to 93.3°C	0°F to 200°F
Neoprene	-17.8°C to 93.3°C	0°F to 200°F
Buna-N	-12.2°C to 82.2°C	10°F to 180°F
EPDM	-51.1°C to 137.8°C	-60°F to 280°F
FKM	-40°C to 176.7°C	-40°F to 350°F
Wil-Flex™	-40°C to 107.2°C	-40°F to 225°F
Polyurethane	12.2°C to 65.6°C	10°F to 150°F
Saniflex™	-28.9°C to 104.4°C	-20°F to 220°F
PTFE	-28.9°C to 148.9°C	-20°F to 300°F

NOTE: Not all materials are available for all models. See "Wilden Pump Designation System" on page 5 for material options for your pump.



CAUTION: When choosing pump materials, be sure to check the temperature limits for all wetted components. Example: FKM has a maximum limit of 176.7°C (350°F) but polypropylene has a maximum limit of only 79°C (175°F).



CAUTION: Maximum temperature limits are based upon mechanical stress only. Certain chemicals will significantly reduce maximum safe operating temperatures. Consult engineering guide for chemical compatibility and temperature limits.



CAUTION: Always wear safety glasses when operating pump. If diaphragm rupture occurs, material being pumped may be forced out air exhaust.



WARNING: Prevention of static sparking — If static sparking occurs, fire or explosion could result. Pump, valves, and containers must be properly grounded when handling flammable fluids and whenever discharge of static electricity is a hazard.



CAUTION: Do not exceed 8.6 bar (125 psig) air supply pressure.



CAUTION: Before any maintenance or repair is attempted, the compressed air line to the pump should be disconnected and all air pressure allowed to bleed from pump. Disconnect all intake, discharge and air lines. Drain the pump by turning it upside down and allowing any fluid to flow into a suitable container.



CAUTION: Blow out air line for 10 to 20 seconds before attaching to pump to make sure all pipe line debris is clear. Use an in-line air filter. A 5µ (micron) air filter is recommended.



NOTE: Tighten clamp bands and retainers prior to installation. Fittings may loosen during transportation.



NOTE: When installing PTFE diaphragms, it is important to tighten outer pistons simultaneously (turning in opposite directions) to ensure tight fit.



NOTE: Before starting disassembly, mark a line from each liquid chamber to its corresponding air chamber. This line will assist in proper alignment during reassembly.



CAUTION: Verify the chemical compatibility of the process and cleaning fluid to the pump's component materials in the Chemical Resistance Guide (see E4).



CAUTION: When removing the end cap using compressed air, the air valve end cap may come out with considerable force. Hand protection such as a padded glove or rag should be used to capture the end cap.



NOTE: All non lube-free air-operated pumps must be lubricated. Wilden suggests an arctic 5 weight oil (ISO grade 15). Do not over-lubricate air supply. Over-lubrication will reduce pump performance.



NOTE: UL-listed pumps must not exceed 3.4 bar (50 psig) air supply pressure.



CAUTION: Only explosion proof (NEMA 7) solenoid valves should be used in areas where explosion proof equipment is required.

Section 2

WILDEN PUMP DESIGNATION SYSTEM

**T8 ORIGINAL™
METAL**

**51 mm (2") Pump
Maximum Flow Rate:
617 lpm (163 gpm)**

LEGEND

T8 / X X X X X X / XXX / XX / X XX / XXXX

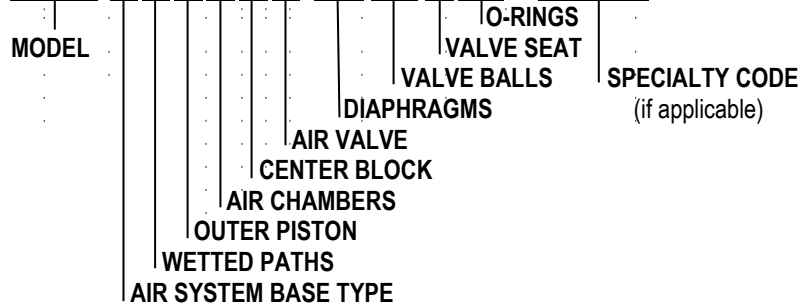

MATERIAL CODES

MODEL

T8 = 51 MM (2")

WETTED PATH

A = ALUMINUM
W = DUCTILE IRON

OUTER PISTON

A = ALUMINUM
W = DUCTILE IRON

AIR CHAMBERS

A = ALUMINUM

CENTER BLOCK

A = ALUMINUM
P = POLYPROPYLENE

AIR VALVE

B = BRASS

DIAPHRAGMS

BNS = BUNA-N (Red Dot)
BNU = BUNA-N, ULTRA-FLEX™
EPS = EPDM (Blue Dot)
EPU = EPDM, ULTRA-FLEX™
FSS = SANIFLEX™ [Hytrel® (Cream)]
NES = NEOPRENE (Green Dot)
NEU = NEOPRENE, ULTRA-FLEX™
PUS = POLYURETHANE (Clear)
TEU = PTFE W/EPDM
 BACK-UP (White)
TNU = PTFE W/NEOPRENE
 BACK-UP (White)
TSU = PTFE W/SANIFLEX™
 BACK-UP (White)
VTS = FKM® (White Dot)
VTU = FKM®, ULTRA-FLEX™
WFS = WIL-FLEX™ [Santoprene®
 (Orange Dot)]
XBS = CONDUCTIVE BUNA-N
 (Two Red Dots)

VALVE BALLS

BN = BUNA-N (Red Dot)
FS = SANIFLEX™ [Hytrel® (Cream)]
FV = SANITARY FKM® (Two White Dots)
EP = EPDM (Blue Dot)
NE = NEOPRENE (Green Dot)
PU = POLYURETHANE (Brown)
TF = PTFE (White)
VT = FKM® (White Dot)
WF = WIL-FLEX™ [Santoprene®
 (Orange Dot)]

VALVE SEATS

A = ALUMINUM
BN = BUNA-N (Red Dot)
EP = EPDM (Blue Dot)
FS = SANIFLEX™
 [Hytrel® (Cream)]
H = ALLOY C*
M = MILD STEEL*
NE = NEOPRENE (Green Dot)
PU = POLYURETHANE (Clear)
S = STAINLESS STEEL*
VT = FKM® (White Dot)
WF = WIL-FLEX™ [Santoprene®
 (Orange Dot)]
*No valve seat o-ring required.

VALVE SEATS O-RINGS

FS = FLUORO-SEAL™
TF = PTFE (White)

SPECIALTY CODES

0014 BSPT	0046 Stallion®, internals, BSPT	0055 Stallion®, spark free, BSPT
0030 Screen based	0048 Stallion®, internals	0112 Stallion®, footed, spark free, without handles
0033 Screen based, spark free	0049 Stallion®, aluminum screen base	0113 Stallion®, internals, spark free, BSPT
0036 Screen based, BSPT	0050 Stallion®	0115 Stallion®, footed, spark free, BSPT, without handles
0037 Screen based, spark free, BSPT	0051 Stallion®, BSPT	0116 Stallion®, BSPT, without handles
0039 Screen based, polyurethane screen	0052 Stallion®, spark free	0117 Stallion®, footed, BSPT, without handles
0044 Stallion®, balls & seats ONLY	0053 Stallion®, footed, BSPT	0231 Stallion®, externals (screen & handles)
0045 Stallion®, shaft & bumpers ONLY	0054 Stallion®, footed	0233 Stallion®, externals (screen & handles), BSPT

NOTE: Most Elastomeric Materials use colored dots for identification.

NOTE: Not all models are available with all material options.

FKM® is a registered trademarks of DuPont Dow Elastomers.

Santoprene® is a registered trademark of Monsanto Company, licensed to Advanced Elastomer Systems, L.P.

Hytrel® is a registered trademark of DuPont Dow Elastomers.

Section 3

HOW IT WORKS — PUMP

The Wilden diaphragm pump is an air-operated, positive displacement, self-priming pump. These drawings show the flow pattern through the pump upon its initial stroke. It is assumed the pump has no fluid in it prior to its initial stroke.

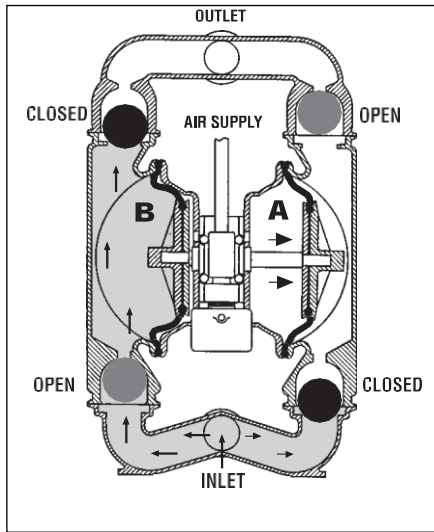

FIGURE 1 The air valve directs pressurized air to the back side of diaphragm A. The compressed air is applied directly to the liquid column separated by elastomeric diaphragms. The diaphragm acts as a separation membrane between the compressed air and liquid, balancing the load and removing mechanical stress from the diaphragm. The compressed air moves the diaphragm away from the center block of the pump. The opposite diaphragm is pulled in by the shaft connected to the pressurized diaphragm. Diaphragm B is on its suction stroke; air behind the diaphragm has been forced out to the atmosphere through the exhaust port of the pump. The movement of diaphragm B toward the center block of the pump creates a vacuum within chamber B. Atmospheric pressure forces fluid into the inlet manifold forcing the inlet valve ball off its seat. Liquid is free to move past the inlet valve ball and fill the liquid chamber (see shaded area).

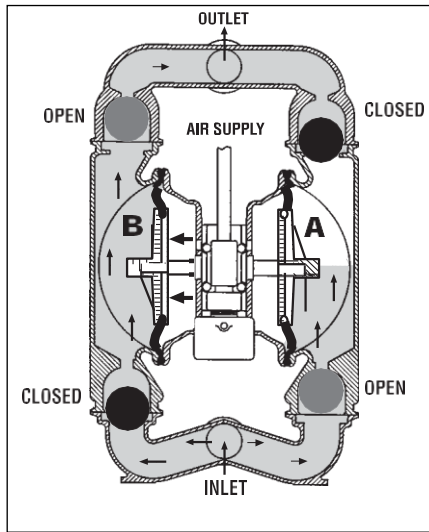

FIGURE 2 When the pressurized diaphragm, diaphragm A, reaches the limit of its discharge stroke, the air valve redirects pressurized air to the back side of diaphragm B. The pressurized air forces diaphragm B away from the center block while pulling diaphragm A to the center block. Diaphragm B is now on its discharge stroke. Diaphragm B forces the inlet valve ball onto its seat due to the hydraulic forces developed in the liquid chamber and manifold of the pump. These same hydraulic forces lift the discharge valve ball off its seat, forcing fluid to flow through the pump discharge. The movement of diaphragm A toward the center block of the pump creates a vacuum within liquid chamber A. Atmospheric pressure forces fluid into the inlet manifold of the pump. The inlet valve ball is forced off its seat allowing the fluid being pumped to fill the liquid chamber.

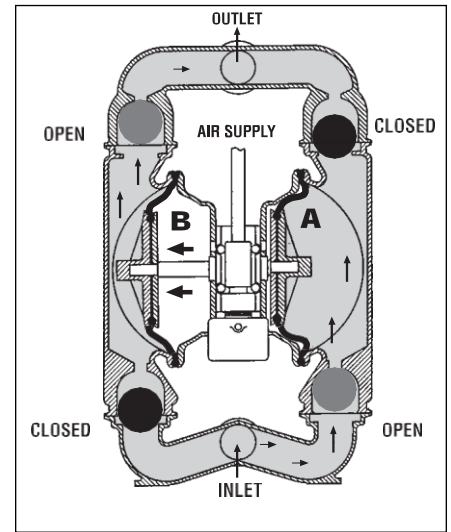
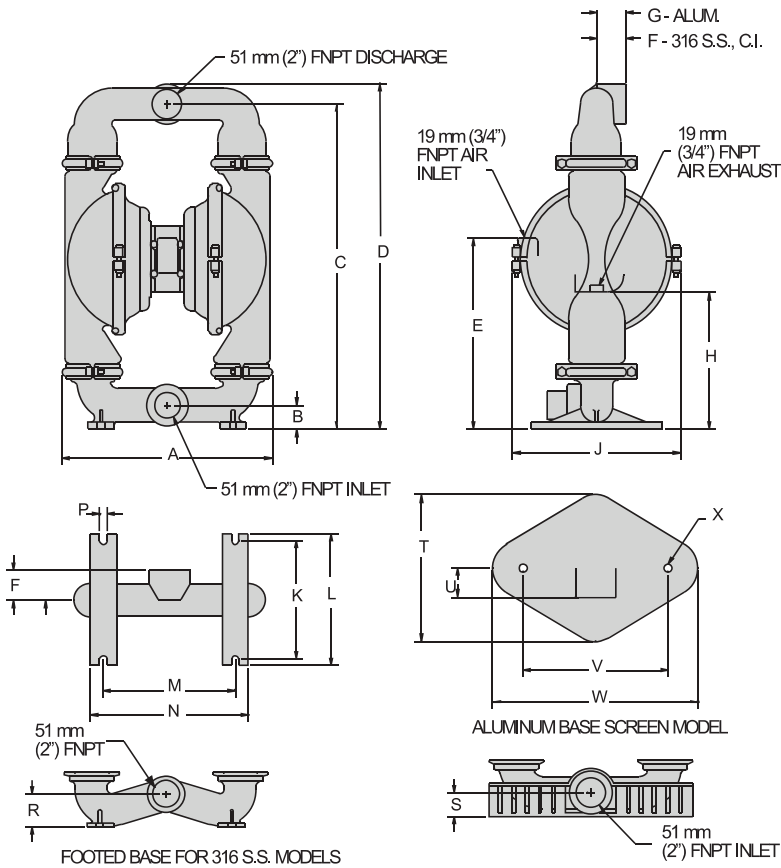

FIGURE 3 At completion of the stroke, the air valve again redirects air to the back side of diaphragm A, which starts diaphragm B on its exhaust stroke. As the pump reaches its original starting point, each diaphragm has gone through one exhaust and one discharge stroke. This constitutes one complete pumping cycle. The pump may take several cycles to completely prime depending on the conditions of the application.

Section 4

DIMENSIONAL DRAWING

T8 Metal



DIMENSIONS

ITEM	METRIC (mm)	STANDARD (inch)
A	404	15.9
B	48	1.9
C	630	24.8
D	668	26.3
E	361	14.2
F	58	2.3
G	61	2.4
H	272	10.7
J	343	13.5
K	229	9.0
L	254	10.0
M	257	10.1
N	312	12.3
P	15	0.6
R	64	2.5
S	51	2.0
T	282	11.1
U	71	2.8
V	282	11.1
W	386	15.2
X	Ø15	Ø0.6
A	404	15.9
B	48	1.9

BSP threads available.

DIMENSIONAL DRAWING

T8 Metal Stallion®

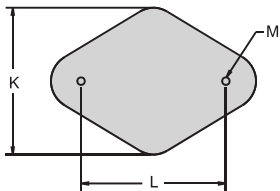
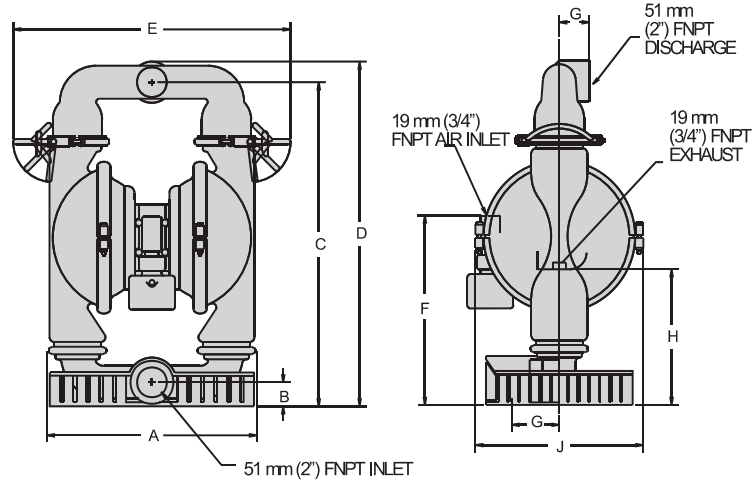

DIMENSIONS

ITEM	METRIC (mm)	STANDARD (inch)
A	409	16.1
B	46	1.8
C	625	24.6
D	666	26.2
E	610	24.0
F	376	14.8
G	61	2.4
H	264	10.4
J	345	13.6
K	282	11.1
L	279	11.0
M	Ø15	Ø0.6

BSP threads available.

**T8 METAL
PTFE-FITTED**

Height 668 mm (26.3")
 Width 404 mm (15.9")
 Depth 343 mm (13.5")
 Est. Ship Weight .. Aluminum 33.1 kg (72 lbs)
 Cast Iron 52.4 kg (114 lbs)
 316 Stainless Steel 48.8 kg (106 lbs.)
 Alloy C 53.4 kg (116 lbs.)
 Air Inlet.....19 mm (3/4")
 Inlet..... 51 mm (2")
 Outlet 51 mm (2")
 Suction Lift 3.7 m Dry (12')
 9.5 m Wet (31')
 Disp. Per Stroke¹..... 1.51 L (0.40 gal.)
 Max. Flow Rate..... 534 lpm (141 gpm)
 Max. Size Solids..... 6.4 mm (1/4")

¹Displacement per stroke was calculated at 4.8 bar (70 psig) air inlet pressure against a 2 bar (30 psig) head pressure.

Example: To pump 284 lpm (75 gpm) against a discharge pressure head of 2.1 bar (30 psig) requires 4.1 bar (60 psig) and 102 Nm³/h (60 scfm) air consumption. (See dot on chart.)

Caution: Do not exceed 8.6 bar (125 psig) air supply pressure.

**T8 METAL STALLION
ULTRA-FLEX™-FITTED**

Height 668 mm (26.3")
 Width 610 mm (24.0")
 Depth 345 mm (13.6")
 Est. Ship Weight Aluminum 33 kg (72 lbs)
 Cast Iron 52 kg (114 lbs)
 316 Stainless Steel 48 kg (106 lbs.)
 Air Inlet.....19 mm (3/4")
 Inlet..... 51 mm (2")
 Outlet 51 mm (2")
 Suction Lift 3.4 m Dry (11')
 9.5 m Wet (31')
 Disp. Per Stroke¹..... 1.66 l (0.44 gal.)
 Max. Flow Rate..... 568 lpm (150 gpm)
 Max. Size Solids..... 19.0 mm (1/4")

¹Displacement per stroke was calculated at 4.8 bar (70 psig) air inlet pressure against a 2 bar (30 psig) head pressure.

Example: To pump 322 lpm (85 gpm) against a discharge pressure head of 2.1 bar (30 psig) requires 4.1 bar (60 psig) and 110.5 Nm³/h (65 scfm) air consumption. (See dot on chart.)

Caution: Do not exceed 8.6 bar (125 psig) air supply pressure.

PERFORMANCE

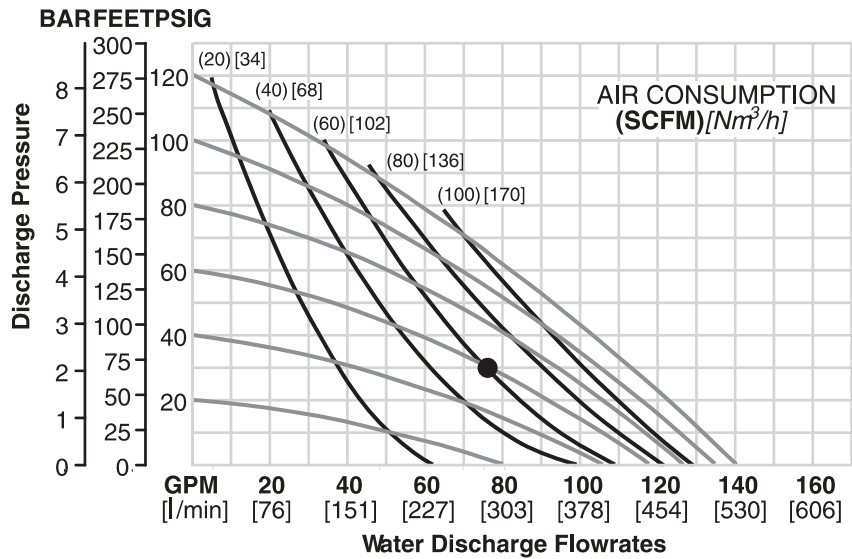

Flow rates indicated on chart were determined by pumping water.

For optimum life and performance, pumps should be specified so that daily operation parameters will fall in the center of the pump performance curve.

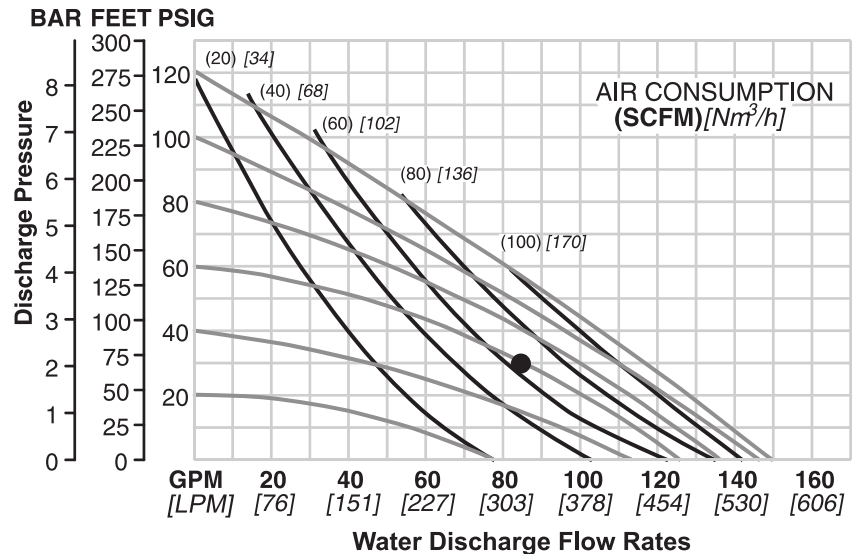

Flow rates indicated on chart were determined by pumping water.

For optimum life and performance, pumps should be specified so that daily operation parameters will fall in the center of the pump performance curve.

SUCTION LIFT CURVES

T8 METAL SUCTION-LIFT CAPABILITY

Suction lift curves are calibrated for pumps operating at 305 m (1,000') above sea level. This chart is meant to be a guide only. There are many variables which can affect your pump's operating characteristics. The number of intake and discharge elbows, viscosity of pumping fluid, elevation (atmospheric pressure) and pipe friction loss all affect the amount of suction lift your pump will attain.

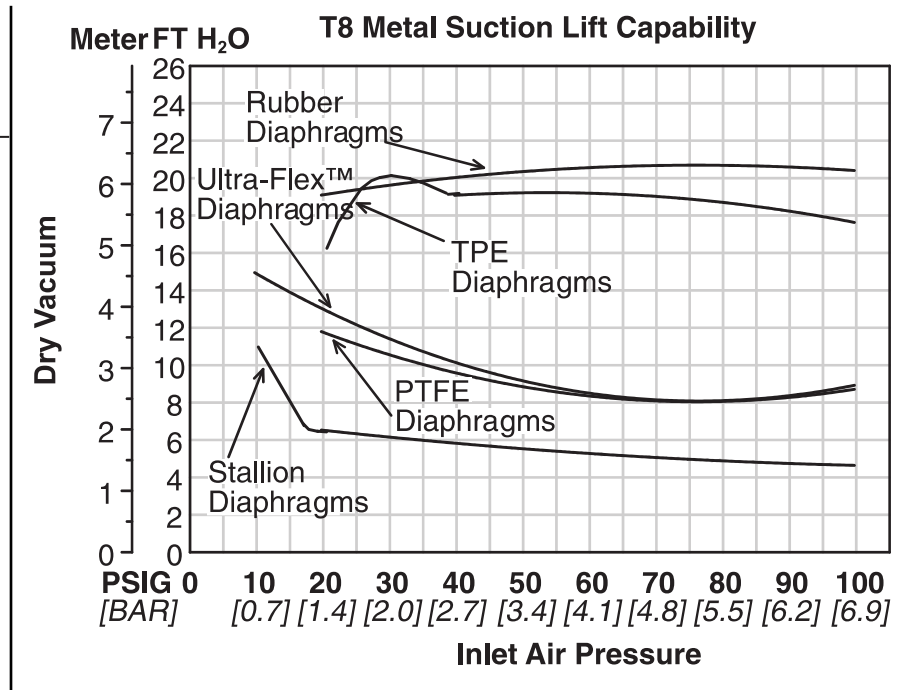

Section 6

Suggested Installation, Operation, Maintenance and Troubleshooting

The Model T8 Metal pump has a 51 mm (2") inlet and 51 mm (2") outlet and is designed for flows to 617 lpm (163 gpm). Refer to Section 5 for performance characteristics. The T8 Metal pump is manufactured with wetted parts of aluminum, 316 Stainless Steel, and Cast Iron. The center block of the T8 Metal pump is constructed of polypropylene, aluminum, nickel-plated aluminum, PTFE-coated aluminum, or stainless steel. A variety of diaphragms, valve balls, valve seats and o-rings are available to satisfy temperature, chemical compatibility, abrasion and flex concerns.

The suction pipe size should be at least 51 mm (2") diameter or larger if highly viscous material is being pumped. The suction hose must be non-collapsible, reinforced type as the T8 is capable of pulling a high vacuum. Discharge piping should be at least 51 mm (2"); larger diameter can be used to reduce friction losses. It is critical that all fittings and connections are airtight or a reduction or loss of pump suction capability will result.

Installation

Months of careful planning, study, and selection efforts can result in unsatisfactory pump performance if installation details are left to chance.

Premature failure and long term dissatisfaction can be avoided if reasonable care is exercised throughout the installation process.

Location

Noise, safety, and other logistical factors usually dictate that "utility" equipment be situated away from the production floor. Multiple installations with conflicting requirements can result in congestion of utility areas, leaving few choices for siting of additional pumps.

Within the framework of these and other existing conditions, every pump should be located in such a way that four key factors are balanced against each other to maximum advantage.

- **Access:** First of all, the location should be accessible. If it's easy to reach the pump, maintenance personnel will have an easier time carrying out routine inspections and adjustments. Should major repairs become necessary, ease of access can play a key role in speeding the repair process and reducing total downtime.
- **Air Supply:** Every pump location should have an air line large enough to supply the volume of air necessary to achieve the desired pumping rate (see pump performance chart). Use air pressure up to a maximum of 8.6 bar (125 psig) depending upon pumping requirements. The use of an air filter before the pump will ensure that the majority of any pipeline contaminants will be eliminated. For best results, the pumps should use an air filter, regulator, and lubricator system.
- **Elevation:** Selecting a site that is well within the pump's suction lift capability will assure that loss-of-prime troubles will be eliminated. In addition, pump efficiency can be adversely affected if proper attention is not given to elevation (see pump performance chart).
- **PIPING:** Final determination of the pump site should not be made until the piping problems of each possible location have been evaluated. The impact of current and future installations should be considered ahead of time to make sure that inadvertent restrictions are not created for any remaining sites.

The best choice possible will be a site involving the shortest and the straightest hook-up of suction and discharge piping. Unnecessary elbows, bends, and fittings should be avoided. Pipe sizes should be selected so as to keep friction losses within practical limits. All piping should be supported independently of the pump. In addition, it should line up without placing stress on the pump fittings.

Expansion joints can be installed to aid in absorbing the forces created by the natural reciprocating action of the pump. If the pump is to be bolted down to a solid foundation, a mounting pad placed between the pump and foundation will assist in minimizing pump vibration. Flexible connections between the pump and rigid piping will also assist in minimizing pump vibration. If quick-closing valves are installed at any point in the discharge system, or if pulsation within a system becomes a problem, a surge suppressor should be installed to protect the pump, piping and gauges from surges and water hammer.

When pumps are installed in applications involving flooded suction or suction head pressures, a gate valve should be installed in the suction line to permit closing of the line for pump service.

The T4 can be used in submersible applications only when both wetted and non-wetted portions are compatible with the material being pumped. If the pump is to be used in a submersible application, a hose should be attached to the pump's air exhaust and the exhaust air piped above the liquid level.

If the pump is to be used in a self-priming application, be sure that all connections are airtight and that the suction lift is within the pump's ability. Note: Materials of construction and elastomer material have an effect on suction lift parameters. Please refer to pump performance data.

Pumps in service with a positive suction head are most efficient when inlet pressure is limited to 0.5–0.7 bar (7–10 psig). Premature diaphragm failure may occur if positive suction is 0.8 bar (11 psig) and higher.

THE MODEL T8 WILL PASS 6.4 mm (1/4") SOLIDS. T8 STALLION WILL PASS 19 mm (3/4") SOLIDS. WHENEVER THE POSSIBILITY EXISTS THAT LARGER SOLID OBJECTS MAY BE SUCKED INTO THE PUMP, A STRAINER SHOULD BE USED ON THE SUCTION LINE.

CAUTION: DO NOT EXCEED 8.6 BAR (125 PSIG) AIR SUPPLY PRESSURE.

BLOW OUT AIR LINE FOR 10 TO 20 SECONDS BEFORE ATTACHING TO PUMP TO MAKE SURE ALL PIPE LINE DEBRIS IS CLEAR. ALWAYS USE AN IN-LINE AIR FILTER.

PUMPS SHOULD BE THOROUGHLY FLUSHED WITH WATER BEFORE INSTALLING INTO PROCESS LINES. FDA AND USDA PUMPS SHOULD BE CLEANED AND/OR SANITIZED BEFORE USE ON EDIBLE PRODUCTS.

CAUTION: DO NOT HANG T8 STALLION PUMPS BY THEIR HANDLES.

Suggested Installation, Operation, Maintenance and Troubleshooting

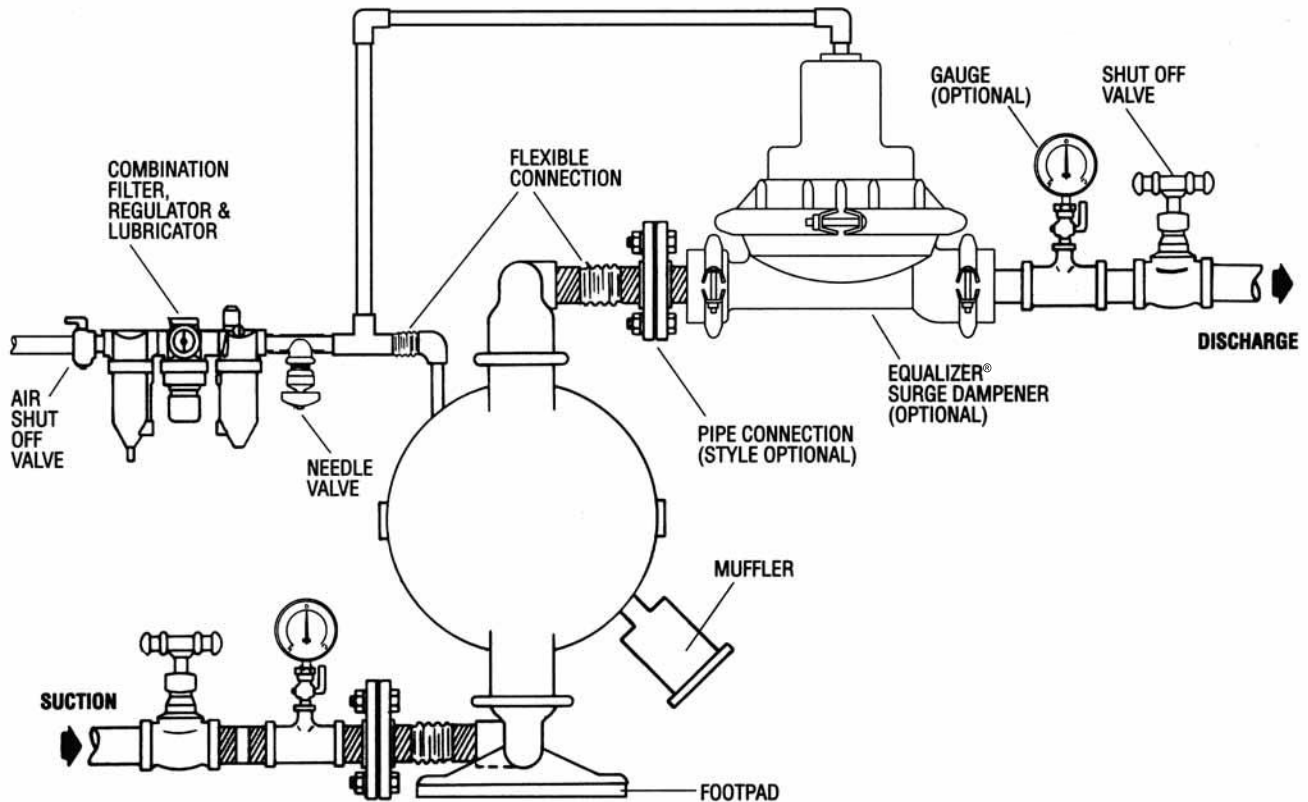

NOTE: In the event of a power failure, the shutoff valve should be closed, if the restarting of the pump is not desirable once power is regained.

Air-Operated Pumps: To stop the pump from operating in an emergency situation, simply close the “shut-off” valve (user supplied) installed in the air supply line. A properly functioning valve will stop the air supply to the pump, therefore stopping output. This shut-off valve should be located far enough away from the pumping equipment such that it can be reached safely in an emergency situation.

Operation

The T8 is not pre-lubricated, and may require in-line lubrication. Pump discharge rate can be controlled by limiting the volume and/or pressure of the air supply to the pump (preferred method). A regulator is used to regulate air pressure. A needle valve is used to regulate air volume. Pump discharge rate can also be controlled by throttling the pump discharge by partially closing a valve in the discharge line of the pump. This action increases friction loss which reduces flow rate. This is useful when the need exists to control the pump from a remote location. When the pump discharge pressure equals or exceeds the air supply pressure, the pump will stop; no bypass or pressure relief valve is needed, and pump damage will not occur. The pump has reached a “deadhead” situation and can be restarted by reducing the fluid discharge pressure or increasing the air inlet pressure. The Wilden T8 pump runs solely on compressed air and does not generate heat, therefore your process fluid temperature will not be affected.

Maintenance and Inspections

Since each application is unique, maintenance schedules may be different for every pump. Frequency of use, line pressure, viscosity and abrasiveness of process fluid all affect the parts life of a Wilden pump. Periodic inspections have been found to offer the best means for preventing unscheduled pump downtime. Personnel familiar with the pump's construction and service should be informed of any abnormalities that are detected during operation.

Records

When service is required, a record should be made of all necessary repairs and replacements. Over a period of time, such records can become a valuable tool for predicting and preventing future maintenance problems and unscheduled downtime. In addition, accurate records make it possible to identify pumps that are poorly suited to their applications.

Suggested Installation, Operation, Maintenance and Troubleshooting

Troubleshooting

Pump will not run or runs slowly.

1. Check air inlet screen and air filter for debris.
2. Check for sticking air valve, flush air valve in solvent.
3. Check for worn out air valve. If piston face in air valve is shiny instead of dull, air valve is probably worn beyond working tolerances and must be replaced.
4. Check center block Glyd™ rings. If worn excessively, they will not seal and air will simply flow through pump and out air exhaust. Use only Wilden Glyd™ rings as they are of special construction and ISO 15-5 wt oil with arctic characteristics.
5. Check for rotating piston in air valve.
6. Check type of lubricant being used. A higher viscosity oil than suggested may cause the piston to stick or run erratically. Wilden suggests the use of a hydraulic oil with arctic characteristics (ISO 15-5 wt).

Pump runs, but little or no product flows.

1. Check for pump cavitation; slow pump speed down to match thickness of material being pumped.
2. Check for sticking ball checks. If material being pumped is not compatible with pump elastomers, swelling may occur. Replace ball checks and o-rings with proper elastomers.

3. Check to make sure all suction connections are air tight, especially clamp bands around intake balls.

Pump air valve freezes.

1. Check for excessive moisture in compressed air. Either install dryer or hot air generator for compressed air.

Air bubbles in pump discharge.

1. Check for ruptured diaphragm.
2. Check tightness of clamp bands, especially at intake manifold

Product comes out air exhaust.

1. Check for diaphragm rupture.
2. Check tightness of piston plates to shaft.

Pump rattles.

1. See E9 Troubleshooting Guide.
2. Create false discharge head or suction lift.

Section 7

Disassembly / Reassembly

Pump Disassembly

Tools Required:

- Adjustable Wrench
- 13 mm (1/2") Socket
- 14 mm (9/16") Box Wrench
- 17 mm (11/16") Socket
- 25 mm (1") Box Wrench or Adjustable Wrench
- Vise equipped with soft jaws (such as plywood, plastic or other suitable material)



CAUTION Before any maintenance or repair is attempted, the compressed air line to the pump should be disconnected and all air pressure allowed to bleed from the pump. Disconnect all intake, discharge, and air lines. Drain the pump by turning it upside down and allowing any fluid to flow into a suitable container. Be aware of any hazardous effects of contact with your process fluid.

The Wilden T8 has a 51 mm (2") inlet and 51 mm (2") outlet and is designed for flows up to 617 lpm (163 gpm). The model T8 is available in aluminum, cast iron, or 316 stainless steel wetted parts. The center block is available in polypropylene, aluminum, nickel-plated aluminum, PTFE-coated aluminum and 316 stainless steel. All o-rings used in the pump are of a special material and shore hardness that should only be replaced with factory-supplied parts.



NOTE: The model used for these instructions incorporates rubber diaphragms, balls, and seats. Models with PTFE diaphragms, balls and seats are the same except where noted. The procedures for A8 Accu-Flo™ pumps are the same except for the air distribution system.

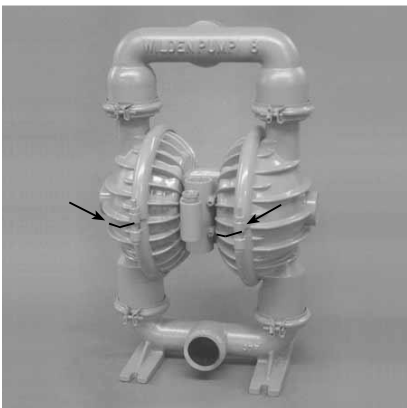

Step 1

Before starting disassembly, mark a line from each liquid chamber to its corresponding air chamber. This line will assist in proper alignment during reassembly.

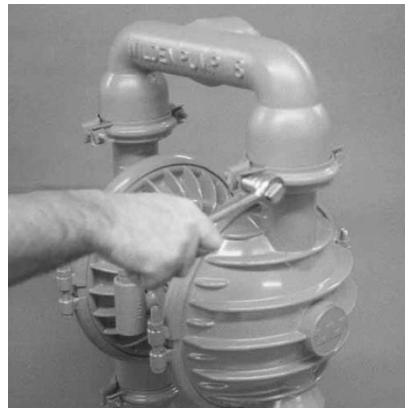

Step 2

Utilizing the 13 mm (1/2") box wrench, remove the two small clamp bands that fasten the discharge manifold to the liquid chambers.

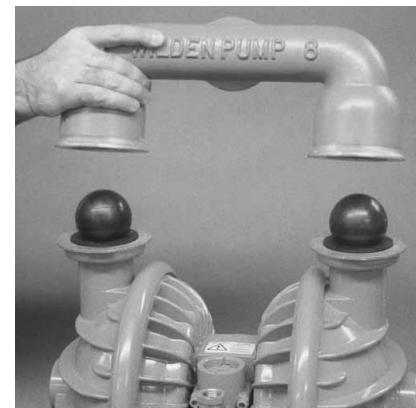

Step 3

Remove the discharge manifold to expose the valve balls and seats. Inspect the ball cage area of the manifold for excessive wear or damage. Remove the discharge valve balls, seats and o-rings from the discharge manifold and inspect for nicks, gouges, chemical attack or abrasive wear. Replace worn parts with genuine Wilden parts for reliable performance. PTFE o-rings should be replaced when reassembled.

Disassembly / Reassembly



Step 4

Remove the two small clamp bands that fasten the intake manifold to the liquid chambers.

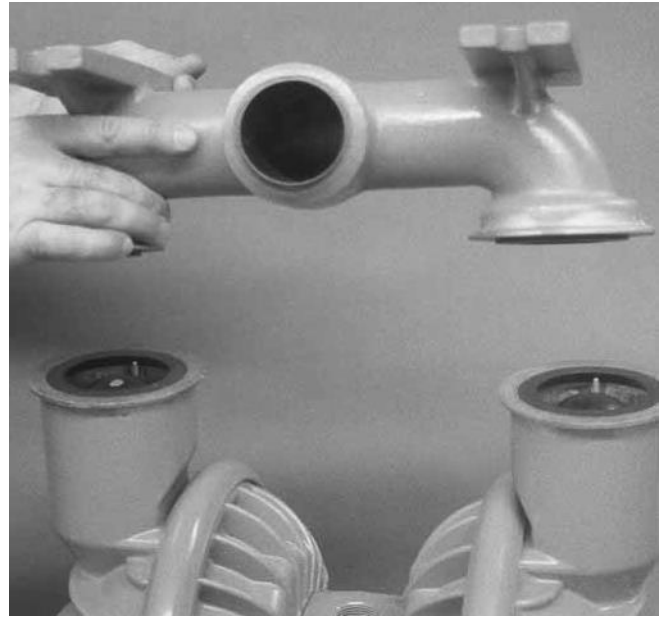

Step 5

Lift the intake manifold away to expose the valve balls and seats. Inspect intake valve ball cage for excessive wear or damage. Remove the intake valve balls, seats and o-rings from the discharge manifold and inspect for nicks, gouges, chemical attack or abrasive wear. Replace worn parts with genuine Wilden parts for reliable performance. PTFE o-rings should be replaced when reassembled.

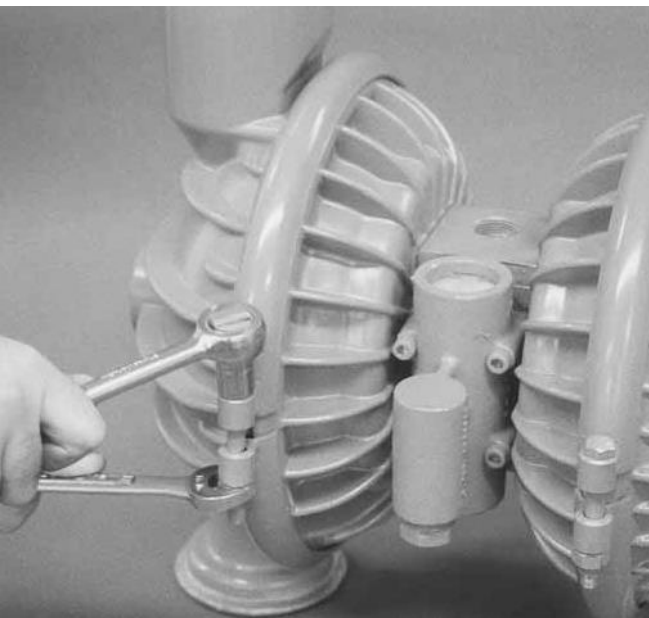

Step 6

With 14 mm (9/16") socket and 17 mm (11/16") box wrench, remove one set of large clamp bands that attach liquid chamber to center section assembly.

WIL-10272-E-01



Step 7

Lift liquid chamber away from center section to expose diaphragm and outer piston.

Disassembly / Reassembly



Step 8

Using a 25 mm (1") box wrench, adjustable wrench, or by rotating the diaphragm by hand, remove the diaphragm assembly.



Step 9A

⚠ NOTE: Due to varying torque values, one of the following two conditions may occur:

- 1) The outer piston, diaphragm and inner piston remain attached to the shaft and the entire assembly can be removed from the center section.



Step 9B

2) The outer piston, diaphragm, and inner piston separate from the shaft which remains connected to the opposite side diaphragm assembly. Repeat disassembly instructions for opposite liquid chamber. Inspect diaphragm assembly and shaft for signs of wear or chemical attack. Replace all worn parts with genuine Wilden parts for reliable performance.



Step 10

To remove the diaphragm assembly from the shaft, secure shaft with soft jaws (a vise fitted with plywood or other suitable material) to ensure shaft is not nicked, scratched, or gouged. Using an adjustable wrench, remove diaphragm assembly from shaft. Inspect all parts for wear and replace with genuine Wilden parts if necessary.

Disassembly / Reassembly

Air Valve / Center Section Disassembly

The air valve assembly consists of both the air valve body and piston and the center block. The unique design of the air valve relies only on differential pressure to effect the diaphragm shift. It is reliable and simple to maintain. The bushing in the center block, along with the diaphragm shaft, provides the “trigger” to tell the air valve to shift. The following procedure will ensure that the air valve on your Wilden pump will provide long trouble-free service.

AIR VALVE BODY AND PISTON ASSEMBLY AND DISASSEMBLY

The air valve can be disconnected from the pump by removing the four socket head cap screws which attach it to the center block. The piston should move freely and the ports in the piston should line up with the ports on the face of the air valve body (see *Figure D*). The piston should also appear to be dull, dark gray in color. If the piston appears to be a shiny aluminum color, the air valve is probably worn beyond working tolerances and should be replaced.

If the piston does not move freely in the air valve, the entire air valve should be immersed in a cleaning solution.

⚠ NOTE: Do not force the piston by inserting a metal object.

This soaking should remove any accumulation of sludge and grit which is preventing the air valve piston from moving freely. Also, remove and clean the air valve screen.

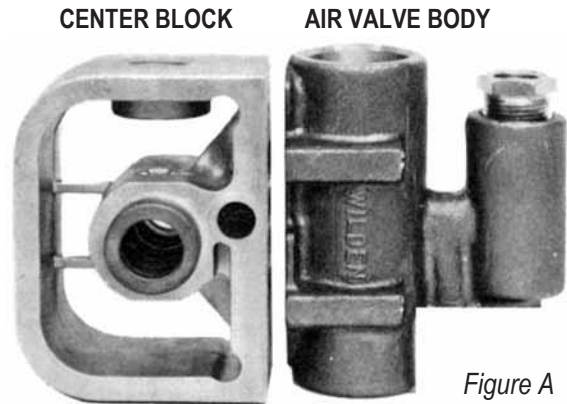

Figure A

AIR VALVE ASSEMBLY

If the air valve piston does not move freely after the above cleaning, the air valve should be disassembled as follows: Remove the snap ring from the top end of the air valve cylinder and apply an air jet to the 3/16-inch hole on the opposite end of the air valve face (see *Figure C*).

⚠ CAUTION: The air valve end cap may come out with considerable force. Inspect the piston and cylinder bore for nicks and scoring.

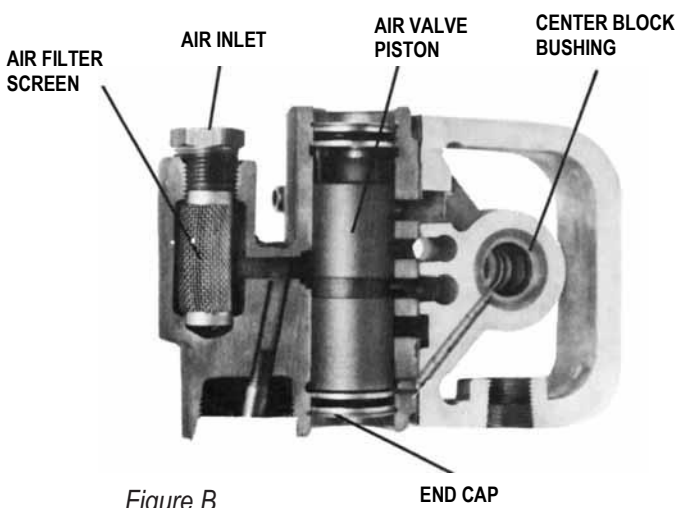

Figure B

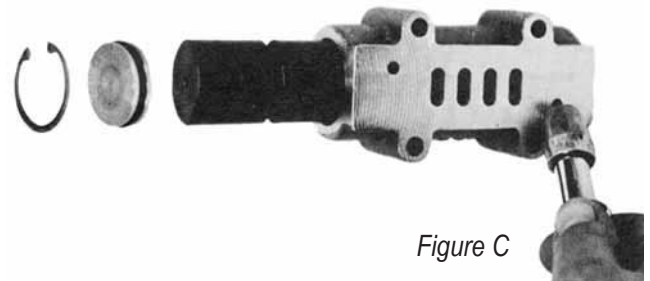

Figure C

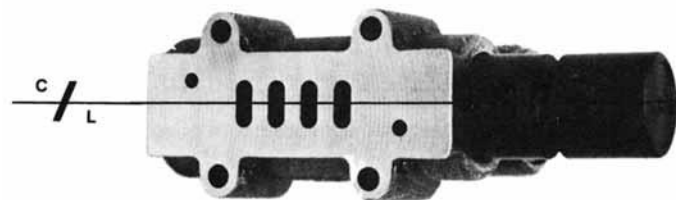

Figure D

Disassembly / Reassembly

The air valve assembly consists of both the air valve body and piston and the center block. The unique design of the air valve relies only on differential pressure to effect the diaphragm shift. It is reliable and simple to maintain. The bushing in the center block, along with the diaphragm shaft, provides the “trigger” to tell the air valve to shift. The following procedure will ensure that the air valve on your Wilden pump will provide long trouble-free service.

GLYD™ RING REPLACEMENT:

When the Glyd™ rings become worn, they will no longer seal and must be replaced. Due to the design characteristics of the Glyd™ rings, it is suggested that you use the Ringer Seal installation kit when replacing Glyd™ rings. Consult EOM- Ringer for installation instructions.

CENTER BLOCK ASSEMBLY:

The pump's center block consists polypropylene or die cast housing with a cast-in-bronze bushing (Figure G). Figure H shows T4 injection-molded polypropylene center section and alignment with air valve. The bushing has eleven grooves cut on the inside diameter. There are seven Glyd™ rings that fit in these grooves (see Figure E). Since these Glyd™ rings form a part of the shifting function of the pump, it is necessary that they be located in the proper grooves. The bronze bushing is replaceable in cast iron center block only. When bushing wear becomes excessive, a new center block must be used.



Figure F
(Side View)

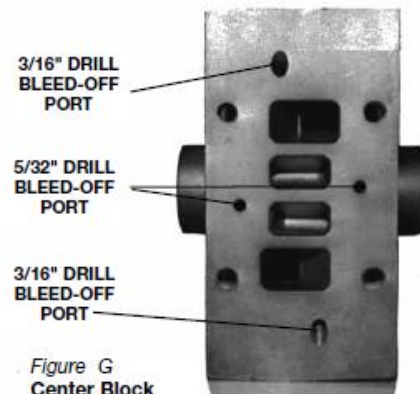
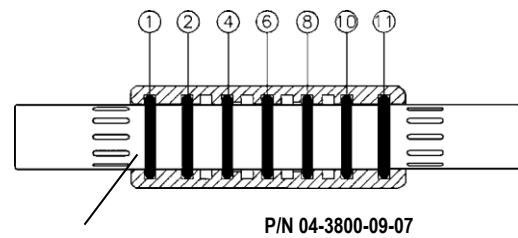

Figure G
Center Block
(Front View)

Grooves In Bushing Which Contain Glyd™ Rings



P/N 04-3100-01-225

P/N 04-3800-09-07

Figure E

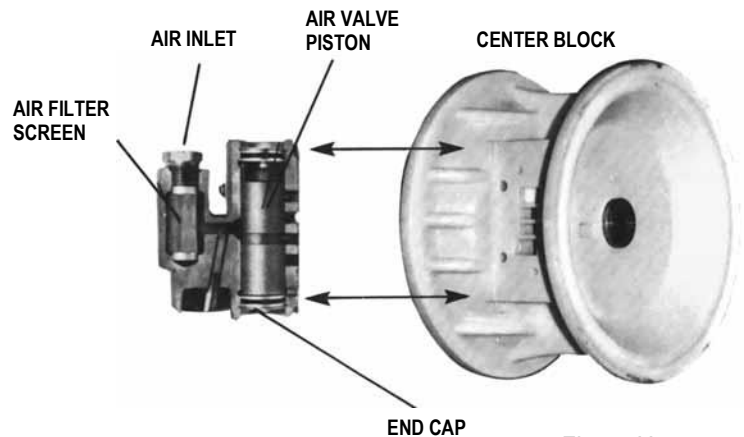

Figure H

*Refer to Section 8 for torque specifications.

Disassembly / Reassembly

REASSEMBLY HINTS & TIPS

REASSEMBLY

Upon performing applicable maintenance to the air distribution system, the pump can now be reassembled. Please refer to the disassembly instructions for photos and parts placement. To reassemble the pump, follow the disassembly instructions in reverse order. The air distribution system needs to be assembled first, then the diaphragms and finally the wetted path. Please find the applicable torque specifications on this page. The following tips will assist in the assembly process.

- Clean the inside of the center section shaft bushing to ensure no damage is done to new seals.
- Stainless bolts should be lubed to reduce the possibility of seizing during tightening.
- Be sure to tighten outer pistons simultaneously on PTFE-fitted pumps to ensure proper torque values.
- Ensure proper alignment on the sealing surfaces of intake and discharge manifolds.
- Liquid chambers are easier to attach when the diaphragm is inverted. Prior to attaching the second water chamber, push diaphragm assembly so that it is as close as possible to the center section.
- PVDF and PFA pumps require PTFE gasket kits for improved sealing. Gasket kits may be installed on other pumps where sealing is an issue.
- When assembling PTFE-coated hardware, care should be taken to keep the coating intact.
- When installing Glyd™ rings, the use of the Wilden Ringer tool simplifies seal installation.

MAXIMUM TORQUE SPECIFICATIONS

Description of Part	Metal Pumps
Air Valve	9.6 N•m (85 in-lbs)
Outer Piston (PTFE-fitted)	108.5 N•m (80 ft-lbs)
Outer Piston (Rubber-fitted)	108.5 N•m (80 ft-lbs)
Small Clamp Band (PTFE-fitted)	6.6 N•m (58 in-lbs)
Small Clamp Band (Rubber-fitted)	2.8 N•m (25 in-lbs)
Large Clamp Band (All)	47.4 N•m (35 ft-lbs)

Description of Part	Metal Pumps
Center Block Assembly	31.1 N•m (23 ft-lbs)
Polyurethane Screen Base	2.3 N•m (20 in-lbs)
Metal Screen Base	9.0 N•m (80 in-lbs)
Inlet Cover	9.0 N•m (80 in-lbs)
Stallion Handle	20.4 N•m (15 ft-lbs)

Gasket Kit / Installation

The Wilden T8 cast iron pumps require PTFE gasket tape on the liquid chambers (P/N 04-9502-99). Other pump types may use PTFE gasket kits for additional sealing characteristics. During reassembly follow the procedures listed in your pump's Engineering, Operation and Maintenance manual.

Carefully prepare sealing surfaces by removing all debris and foreign matter from diaphragm bead and all mating surfaces. If necessary, smooth or deburr all sealing surfaces. Mating surfaces must be properly aligned in order to ensure positive sealing characteristics.

Always wear safety glasses when performing maintenance on any Wilden product.

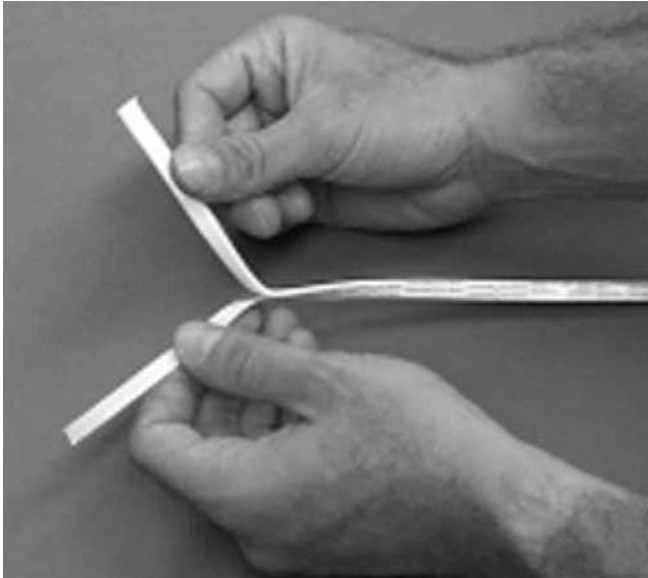

Step 1

Gently remove the adhesive covering from the back of the PTFE tape. Ensure that the adhesive strip remains attached to the PTFE tape.



Step 2

Starting at any point, place the PTFE tape in the center of the diaphragm bead groove on the liquid chamber and press lightly on the tape to ensure that the adhesive holds in place during assembly. Do not stretch the tape during placement in the center of diaphragm bead groove.



Step 3

The end of the tape should overlap approximately 13 mm (1/2"). Proceed to install the PTFE tape on the remaining diaphragm.

Section 9

EXPLODED VIEW AND PARTS LISTING

T8 METAL

Rubber/TPE-Fitted

EXPLODED VIEW

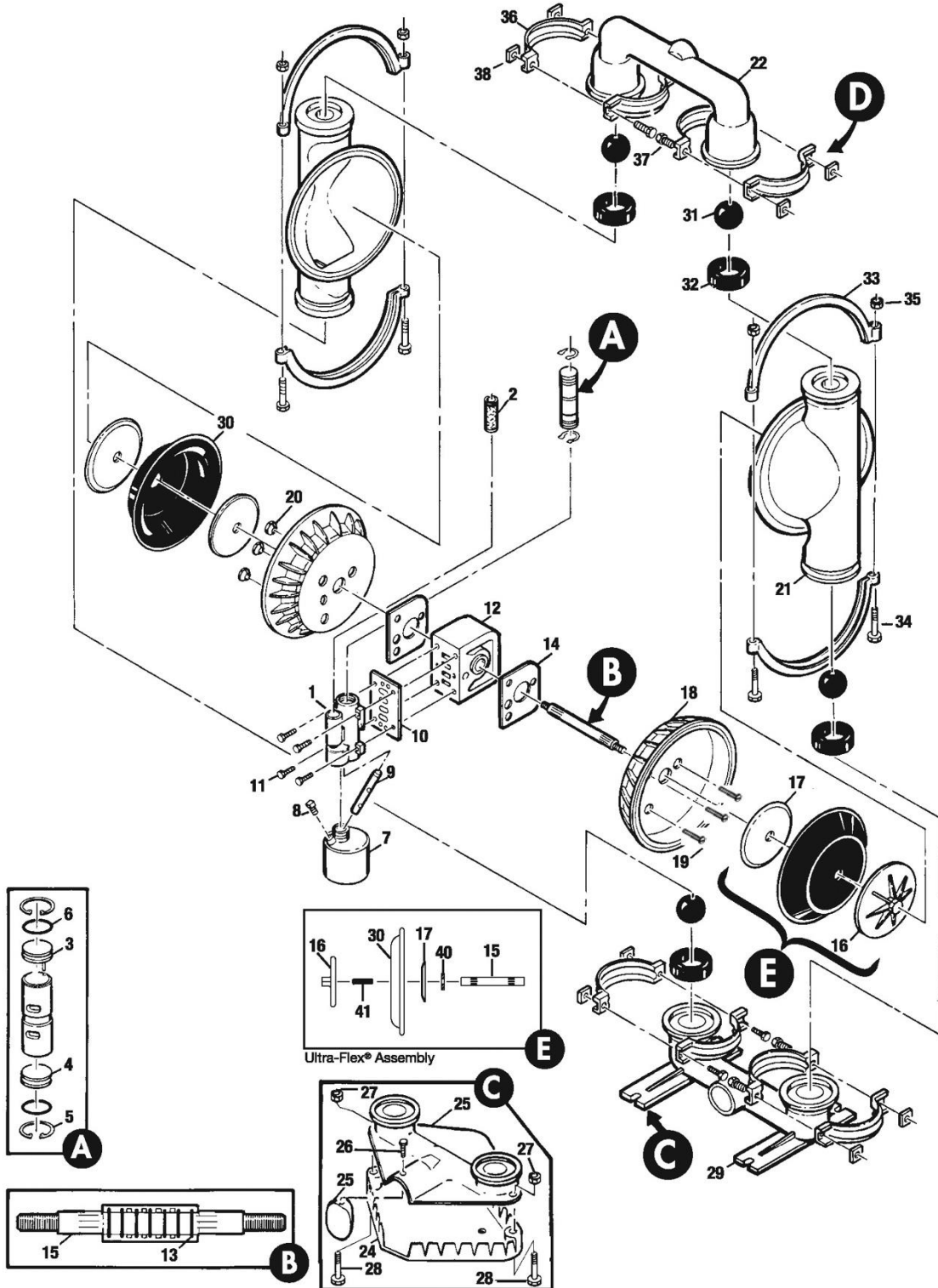

Exploded View and Parts List

Item	Part Description	Qty.	T8/AAAPB/0030 P/N	T8/AAAPB P/N	T8/AAAAB P/N
1	Air Valve Assembly¹	1	08-2000-07	08-2000-07	08-2000-07
2	Air Valve Screen	1	08-2500-07	08-2500-07	08-2500-07
3	Air Valve End Cap w/Guide (Top)	1	08-2300-23	08-2300-23	08-2300-23
4	Air Valve End Cap w/o Guide (Bottom)	1	08-2330-23	08-2330-23	08-2330-23
5	Air Valve Snap Ring	2	08-2650-03	08-2650-03	08-2650-03
6	Air Valve Cap O-Ring	2	08-2390-52	08-2390-52	08-2390-52
7	OilBottle(Optional)w/AirValve08-2050-07	1	08-2850-01	08-2850-01	08-2850-01
8	Plug (Optional)	1	08-7000-07	08-7000-07	08-7000-07
9	Capillary Rod (Optional)	1	08-2900-99	08-2900-99	08-2900-99
10	Air Valve Gasket — Buna-N	1	08-2600-52	08-2600-52	08-2600-52
11	Air Valve Screw 5/16"-18 x 2-1/4"	4	08-6000-08	08-6000-08	08-6000-08
12	Center Block	1	08-3100-20-225	08-3100-20-225	08-3100-01-225
13	Center Block Glyd™ Ring	7	08-3210-55-225	08-3210-55-225	08-3210-55-225
14	Block Gasket — Buna-N	2	08-3520-52	08-3520-52	08-3520-52
15	Shaft	1	08-3800-09-07	08-3800-09-07	08-3800-09-07
	Shaft, Ultra-Flex™	1	08-3820-09-07	08-3820-09-07	08-3820-09-07
16	Piston, Outer	2	08-4550-01	08-4550-01	08-4550-01
	Piston, Outer, Ultra-Flex™	2	04-4552-01	04-4552-01	04-4552-01
17	Piston, Inner	2	08-3700-01	08-3700-01	08-3700-01
	Piston, Inner, Ultra-Flex™	2	04-3700-08	04-3700-08	04-3700-08
18	Air Chamber, Counter Sunk	2	08-3650-01	08-3650-01	08-3650-01
19	Air Chamber Screw 3/8"-16 x 3-9/16"	3	08-6200-08	08-6200-08	08-6200-08
20	Air Chamber Cone Nut 3/8"-16	3	08-6550-08	08-6550-08	08-6550-08
21	Liquid Chamber	2	08-5000-01	08-5000-01	08-5000-01
22	Discharge Manifold	1	08-5020-01	08-5020-01	08-5020-01
23	Inlet Housing for Screened Base	1	08-5080-01-30		
24	Screen Base for Item 24	1	08-5620-01		
25	Suction Hook Up Cover for Item 24	1	08-5660-01		
26	Cap Screw for Item 24 3/8"-16 x 7/8"	1	08-6140-08		
27	Cap Screw Nut 3/8"-16	2	02-6430-03		
28	Cap Screw 3/8"-16 x 3"	2	08-6120-08		
29	Inlet Housing for Footed Base	1		08-5080-01	08-5080-01
30	Diaphragm*	2	*	*	*
31	Valve Ball*	4	*	*	*
32	Valve Seat*	4	*	*	*
33	Large Clamp Band Assy.	2	08-7300-08	08-7300-08	08-7300-08
34	Large Carriage Bolt 3/8"-16 x 3"	4	08-6120-08	08-6120-08	08-6120-08
35	Large Hex Nut 3/8"-16	4	08-6450-08	08-6450-08	08-6450-08
36	Small Clamp Band Assy.	4	08-7100-08	08-7100-08	08-7100-08
37	Small Hex Head Cap Screw 5/16"-18 x 1-3/8"	8	08-6050-08	08-6050-08	08-6050-08
38	Small Hex Nut 5/16"-18	8	04-6420-08	04-6420-08	04-6420-08
39	Muffler (not shown)	1	08-3510-99	08-3510-99	08-3510-99
40	Spacer, Ultra-Flex™	2	08-3860-08	08-3860-08	08-3860-08
41	Stud, Ultra-Flex™	1	08-6150-08	08-6150-08	08-6150-08

¹Air Valve Assembly includes parts through 08-2390-52.

²T8 Stallion pumps utilize only four (4) of P/N's 08-6100-03 and 08-6408-08 on the bottom manifold and water chambers.

*Refer to elastomer options in Section 9.

NOTE: BSP threads available.

All boldface items are primary wear parts.

0030 Specialty Code = Screen Base

0050 Specialty Code = Stallion

T8 METAL

Rubber/TPE-Fitted

EXPLODED VIEW

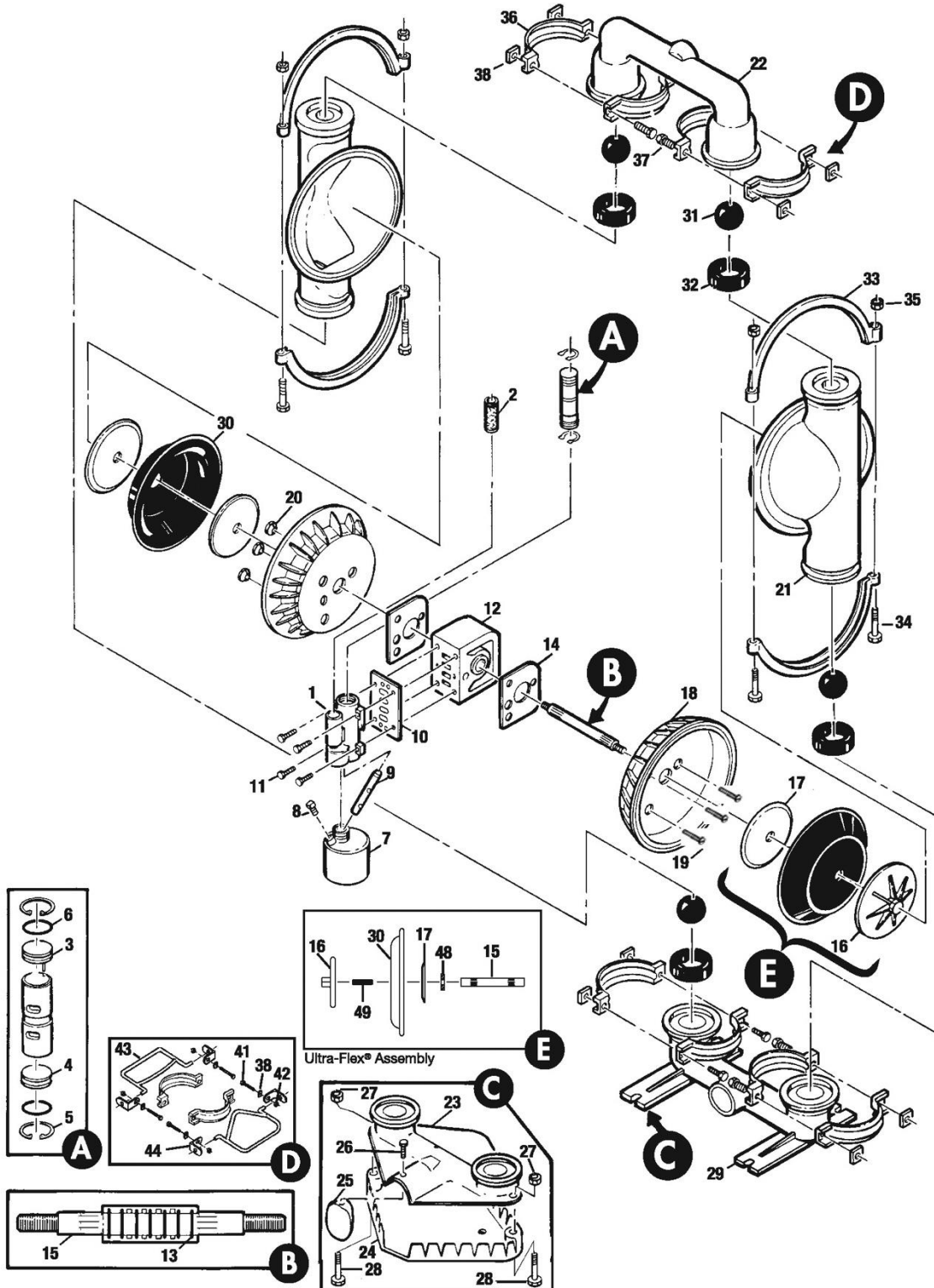

Exploded View and Parts List (Cont'd)

Item	Part Description	Qty.	T8/WSAPB P/N	T8/AAAAB/0050 P/N	T8/AAAAB/0050 P/N
1	Air Valve Assembly^{1,2}	1	08-2000-07	08-2080-07	08-2080-07
2	Air Valve Screen	1	08-2500-07	08-2500-07	08-2500-07
3	Air Valve End Cap w/Guide (Top)	1	08-2300-23	08-2300-23	08-2300-23
4	Air Valve End Cap w/o Guide (Bottom)	1	08-2330-23	08-2330-23	08-2330-23
5	Air Valve Snap Ring	2	08-2650-03	08-2650-03	08-2650-03
6	Air Valve Cap O-Ring	2	08-2390-52	08-2390-52	08-2390-52
7	Oil Bottle (Optional) ²	1	08-2850-01	08-2850-01	08-2850-01
8	Plug (Optional) ²	1	08-7000-07	08-7000-07	08-7000-07
9	Capillary Rod (Optional) ²	1	08-2900-99	08-2900-99	08-2900-99
10	Air Valve Gasket — Buna-N	1	08-2600-52	08-2600-52	08-2600-52
11	Air Valve Screw 5/16"-18 x 2-1/4"	4	08-6000-08	08-6000-08	08-6000-08
12	Center Block	1	08-3100-20-225	08-3100-01-225	08-3100-01-225
13	Center Block Glyd™ Ring	7	08-3210-55-225	08-3210-55-225	08-3210-55-225
14	Block Gasket — Buna-N	2	08-3520-52	08-3520-52	08-3520-52
15	Shaft	1	08-3800-09-07	08-3800-09-65	
	Shaft, Ultra-Flex™	1	08-3820-09-07	08-3820-09-07	08-3820-09-07
16	Piston, Outer	2	08-4550-02	08-4552-01	
	Piston, Outer, Ultra-Flex™	2	08-4560-02	04-4552-01	04-4552-01
17	Piston, Inner	2	08-3700-01	08-3700-01	04-3700-08
	Piston, Inner, Ultra-Flex™	2	04-3700-08	04-3700-08	04-3700-08
18	Air Chamber, Counter Sunk	2	08-3650-01	08-3650-01	08-3650-01
19	Air Chamber Screw 3/8"-16 x 3-9/16"	3	08-6200-08	08-6200-08	08-6200-08
20	Air Chamber Cone Nut 3/8"-16	3	08-6550-08	08-6550-08	08-6550-08
21	Liquid Chamber	2	08-5000-02	08-5000-01	08-5000-01
22	Discharge Manifold	1	08-5020-02	08-5020-01	08-5020-01
23	Inlet Housing for Screened Base	1		08-5080-01-30	08-5080-01-30
24	Screen Base for Item 24	1		08-5620-62	08-5620-62
25	Suction Hook Up Cover for Item 24	1		08-5660-01	08-5660-01
26	Cap Screw for Item 24 & 26 3/8"-16 x 7/8"	1		08-6140-03	08-6140-03
27	Cap Screw Nut 3/8"-16	3		02-6430-03	02-6430-03
28	Cap Screw 3/8"-16 x 3"	3		08-6120-03	08-6120-03
29	Inlet Housing for Footed Base	1	08-5080-02		
30	Diaphragm*	2	*	*	**
31	Valve Ball*	4	*	*	**
32	Valve Seat*	4	*	*	**
33	Large Clamp Band Assy.	2	08-7300-08	08-7300-08	08-7300-08S
34	Large Carriage Bolt 3/8"-16 x 3"	4	08-6120-08	08-6120-08	08-6120-08
35	Large Hex Nut 3/8"-16	4	08-6450-08	08-6450-08	08-6450-08
36	Small Clamp Band Assy.	4	08-7100-08	08-7100-08	08-7100-08S
37	Small Hex Head Cap Screw 5/16"-18 x 1-3/8"	8	08-6050-08	08-6050-08	08-6050-08
38	Small Hex Nut 5/16"-18 ²	8	04-6420-08	04-6420-08	04-6420-08
39	Muffler (not shown)	1	08-3510-99	08-3510-99	08-3510-99
40	Bumper Pad, Nylon (Not shown)	2		08-6900-23-50	08-6900-23-50
41	Screw, HHC, 5/16"-18 x 2	4		08-6050-08-50	08-6050-08-50
42	Nut, Hex, 5/16"-18	4		04-6420-08	04-6420-08
43	Handle, Collapsible ³	2		08-7250-08	08-7250-08
44	Bracket, Handle	4		08-7410-08	08-7410-08
45	Check Body (Not shown)	1		08-3550-01	08-3550-01
46	Check Ball (Not shown)	1		08-1450-51	08-1450-51
47	Pipe Nipple, Check Body (Not shown)	1		08-7420-08	08-7420-08
48	Spacer, Ultra-Flex™	2	08-3860-08	08-3860-08	08-3860-08
49	Stud, Ultra-Flex™	1	08-6150-08		08-6150-08

¹Air Valve Assembly includes parts through 08-2390-52.

²T8 Stallion pumps utilize only four (4) of P/N's 08-6100-03 and 08-6408-08 on the bottom manifold and water chambers.

³DO NOT hang Stallion pumps by their handles.

**Refer to elastomer options in Section 9.

**Refer to Stallion elastomer options in Section 9.

NOTE: BSP threads available.

All boldface items are primary wear parts.

0030 Specialty Code = Screen Base

0050 Specialty Code = Stallion

T8 METAL

PTFE - Fitted

EXPLODED VIEW

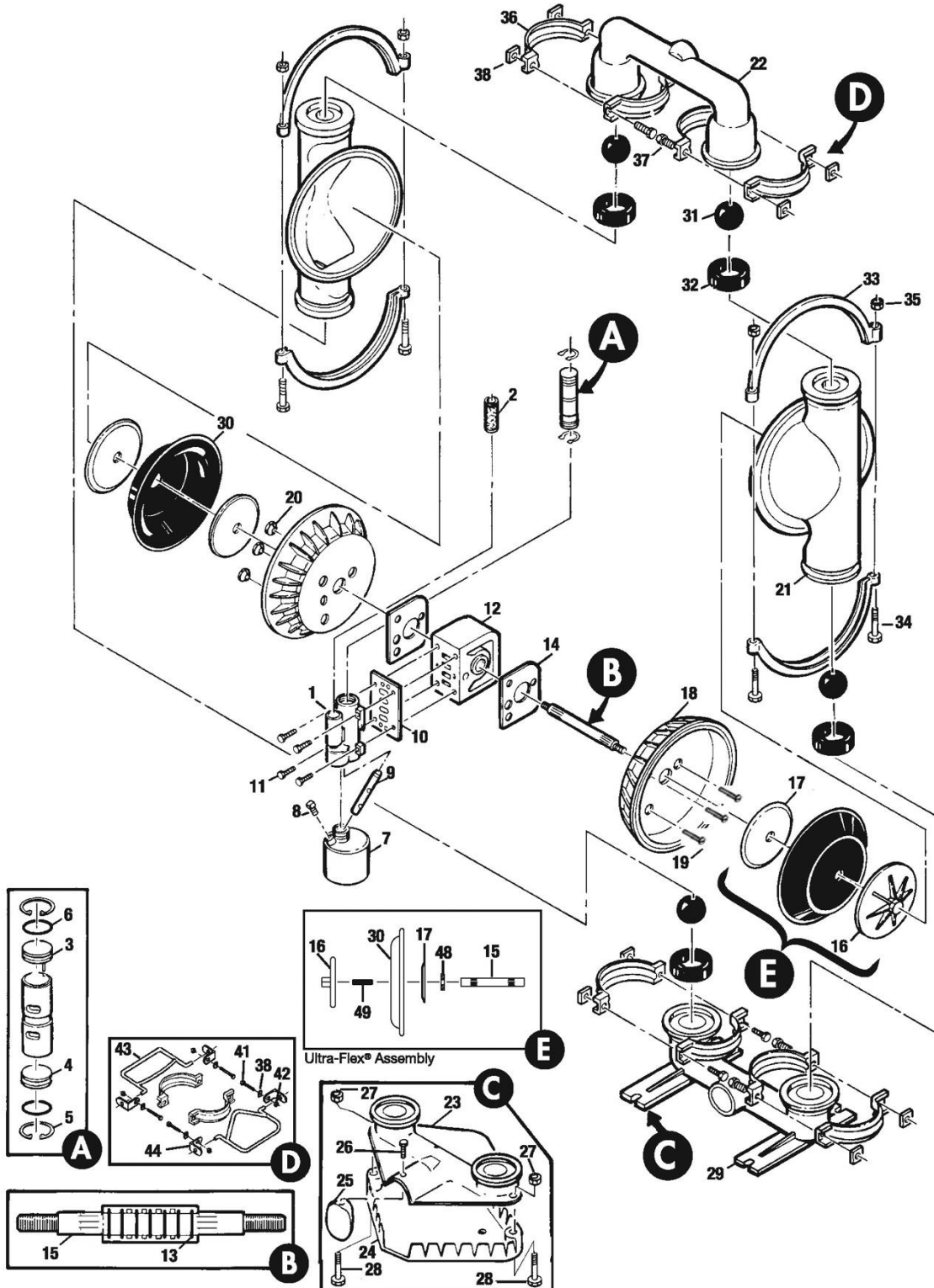

Exploded View and Parts List

Item	Part Description	Qty.	T8/AAAPB P/N	T8/AAAAB P/N
1	Air Valve Assembly¹	1	08-2000-07	08-2000-07
2	Air Valve Screen	1	08-2500-07	08-2500-07
3	Air Valve End Cap w/Guide (Top)	1	08-2300-23	08-2300-23
4	Air Valve End Cap w/o Guide (Bottom)	1	08-2330-23	08-2330-23
5	Air Valve Snap Ring	2	08-2650-03	08-2650-03
6	Air Valve Cap O-Ring	2	08-2390-52	08-2390-52
7	Oil Bottle (Optional)	1	08-2850-01	08-2850-01
8	Plug (Optional)	1	08-7000-07	08-7000-07
9	Capillary Rod (Optional)	1	08-2900-99	08-2900-99
10	Air Valve Gasket — Buna-N	1	08-2600-52	08-2600-52
11	Air Valve Screw 5/16"-18 x 2-1/4"	4	08-6000-08	08-6000-08
12	Center Block	1	08-3100-20-225	08-3100-01-225
13	Center Block Glyd™ Ring	7	08-3210-55-225	08-3210-55-225
14	Block Gasket — Buna-N	2	08-3520-52	08-3520-52
15	Shaft	1	08-3820-09-07	08-3820-09-07
16	Shaft Stud 1/2"-20 x 1-7/8"	2	08-6152-08	08-6152-08
17	Piston, Outer	2	08-4600-01	08-4600-01
18	Piston, Inner	2	08-3750-01	08-3750-01
19	Air Chamber, Counter Sunk	2	08-3650-01	08-3650-01
20	Air Chamber Screw 3/8"-16 x 3-9/16"	3	08-6200-08	08-6200-08
21	Air Chamber Nut 3/8"-16	3	08-6550-08	08-6550-08
22	Water Chamber	2	08-5000-01	08-5000-01
23	Discharge Manifold	1	08-5020-01	08-5020-01
24	Inlet Housing, Footed	1	08-5080-01	08-5080-01
25	Diaphragm²	2	08-1010-55	08-1010-55
26	Diaphragm — Back-up³	2	08-1060-51	08-1060-51
27	Valve Ball²	4	08-1080-55	08-1080-55
28	Valve Seat²	4	08-1121-01	08-1121-01
29	Large Clamp Band Assy.	2	08-7300-03	08-7300-03
30	Large Carriage Bol 3/8"-16 x 3"	4	08-6120-03	08-6120-03
31	Large Hex Nut 3/8"-16	4	08-6450-03	08-6450-03
32	Small Clamp Band Assy.	4	08-7100-03	08-7100-03
33	Small Hex Head Cap Screw 5/16"-18 x 1-3/8"	8	08-6050-03	08-6050-03
34	Small Hex Nut 5/16"-18	8	08-6400-03	08-6400-03
35	PTFE⁴ Valve Seat O-Ring⁴	4	08-1200-55	08-1200-55
	Muffler (not shown)	1	08-3510-99	08-3510-99

Item	Part Description	Qty.	T8/SSAPB P/N	T8/WAAPB P/N
1	Air Valve Assembly¹	1	08-2000-07	08-2000-07
2	Air Valve Screen	1	08-2500-07	08-2500-07
3	Air Valve End Cap w/Guide (Top)	1	08-2300-23	08-2300-23
4	Air Valve End Cap w/o Guide (Bottom)	1	08-2330-23	08-2330-23
5	Air Valve Snap Ring	2	08-2650-03	v08-2650-03
6	Air Valve Cap O-Ring	2	08-2390-52	08-2390-52
7	Oil Bottle (Optional)	1	08-2850-01	08-2850-01
8	Plug (Optional)	1	08-7000-07	08-7000-07
9	Capillary Rod (Optional)	1	08-2900-99	08-2900-99
10	Air Valve Gasket — Buna-N	1	08-2600-52	08-2600-52
11	Air Valve Screw 5/16"-18 x 2-1/4"	4	08-6000-03	08-6000-08
12	Center Block	1	08-3100-20-225	08-3100-20-225
13	Center Block Glyd™ Ring	7	08-3210-55-225	08-3210-55-225
14	Block Gasket — Buna-N	2	08-3520-52	08-3520-52
15	Shaft	1	08-3820-09-07	08-3820-09-07
16	Shaft Stud 1/2"-20 x 1-7/8"	2	08-6152-08	08-6152-08
17	Piston, Outer	2	08-4600-03	08-4600-03
18	Piston, Inner	2	08-3750-01	08-3750-01
19	Air Chamber, Counter Sunk	2	08-3650-01	08-3650-01
20	Air Chamber Screw 3/8"-16 x 3-9/16"	3	08-6200-08	08-6200-08
21	Air Chamber Nut 3/8"-16	3	08-6550-08	08-6550-08
22	Water Chamber	2	08-5000-03	08-5000-02
23	Discharge Manifold	1	08-5020-03	08-5020-02
24	Inlet Housing, Footed	1	08-5080-03	08-5080-02
25	Diaphragm²	2	08-1010-55	08-1010-55
26	Diaphragm — Back-up³	2	08-1060-51	08-1060-51
27	Valve Ball²	4	08-1080-55	08-1080-55
28	Valve Seat²	4	08-1121-03	08-1121-08
29	Large Clamp Band Assy.	2	08-7300-03	08-7300-03
30	Large Carriage Bol 3/8"-16 x 3"	4	08-6120-03	08-6120-03
31	Large Hex Nut 3/8"-16	4	08-6450-03	08-6450-03
32	Small Clamp Band Assy.	4	08-7100-03	08-7100-03
33	Small Hex Head Cap Screw 5/16"-18 x 1-3/8"	8	08-6050-03	08-6050-03
34	Small Hex Nut 5/16"-18	8	08-6400-03	08-6400-03
35	PTFE⁴ Valve Seat O-Ring⁴	4	08-1200-55	08-1200-55
	Muffler (not shown)	1	08-3510-99	08-3510-99

¹Air Valve Assembly includes item numbers 2 through 6.

²Refer to corresponding elastomer options in Section 9.

³Saniflex™ back-up diaphragms, P/N 08-1060-56, are available upon request. Please consult your local distributor.

⁴Fluoro-Seal™ o-rings, P/N 08-1200-34, are available upon request. See elastomer chart options in Section 9.

NOTE: BSP threads available.

All boldface items are primary wear parts

Section 9

Elastomer Options

T8 Metal Pumps

Material	Diaphragms (2) P/N	Ultra-Flex™* Diaphragms (2) P/N	Valve Balls (4) P/N	Valve Seats (4) P/N	Valve Seat ³ O-Rings (4) P/N
Polyurethane	08-1010-50		08-1080-50	08-1120-50	
Neoprene	08-1010-51	08-1020-51	08-1080-51	08-1120-51	
Buna-N	08-1010-52	08-1020-52	08-1080-52	08-1120-52	
EPDM	08-1010-54	08-1020-54	08-1080-54	08-1120-54	
FKM [®]	08-1010-53	08-1020-53	08-1080-53	08-1120-53	
Saniflex™	08-1010-56		08-1080-56	08-1120-56	08-1200-56
PTFE	08-1010-55		08-1080-55		08-1200-55 ²
Tetra-Flex™ PTFE	08-1010-64				
Neoprene Backup ²	08-1060-51 ¹				
Wil-Flex™	08-1010-58		08-1080-58	08-1120-58	
Fluoro-Seal™					08-1200-34 ²
Aluminum				08-1121-01	
Stainless Steel				08-1121-03	
Alloy C				08-1121-04	
Mild Steel				08-1121-08	

¹Use Neoprene backup diaphragms with PTFE diaphragms only.

²Utilized in conjunction with metallic seat.

³Rubber valve seats do not require an o-ring.

T8 Metal STALLION Pumps

Material	Diaphragms (2) P/N	Valve Balls (4) P/N	Valve Seats (4) P/N
Polyurethane	08-1010-50	08-1080-62-50	08-1120-62-50
Wil-Flex™	08-1010-58	08-1080-58-50	08-1120-58-50
Saniflex™	08-1010-56	08-1080-56-50	08-1120-56-50
Neoprene	08-1010-51	08-1080-51-50	08-1120-51-50
Buna-N	08-1010-52	08-1080-52-50	08-1120-52-50
FKM	08-1020-53	08-1080-53-50	08-1120-53-50
EPDM	08-1020-54	08-1080-54-50	08-1120-54-50

Notes

Notes

PSG
22069 Van Buren Street
Grand Terrace, CA 92313-5651 USA
P: +1 (909) 422-1730 • F: +1 (909) 783-3440
psgdover.com



Where Innovation Flows