

BALDOR® • RELIANCE

Product Information Packet

CEM7058T-I

25//20HP,1780//1470RPM,3PH,60//50HZ,284T

Part Detail							
Revision:	AA	Status:	PRD/A	Change #:		Proprietary:	No
Type:	AC	Prod. Type:	1050M	Elec. Spec:	10WGW717	CD Diagram:	CD0005
Enclosure:	XPFC	Mfg Plant:		Mech. Spec:	10E949	Layout:	10LYE949
Frame:	284TC	Mounting:	F1	Poles:	04	Created Date:	06-10-2010
Base:	RG	Rotation:	R	Insulation:	F	Eff. Date:	02-11-2016
Leads:	9#10					Replaced By:	
Literature:		Elec. Diagram:					

Nameplate NP0977XPSLEV										
NO.							CC	010A		
SER.							TEMP CODE	T3C		
SPEC.	10E949W717G3									
CAT.NO.	CEM7058T-I									
HP	25//20 NEMA MG-1 PT.5,IP55									
VOLTS	230/460//190/380									
AMPS	61/30.5//59/29.5									
RPM	1780//1470						MOTOR WEIGHT	494		
HERTZ	60//50		PH	3	CL	F	DE BRG	6311		
SER.F.	1.15		DES	A	CODE	G	ODE BRG	6309		
FRAME	284TC		GREASE	POLYREX EM						
RATING	40C AMB-CONT									
USABLE AT 208V	65		NEMA-NOM-EFF			93.6	PF	82		
	55C AMB @ 1.0 SF 60C RISE									

Parts List		
Part Number	Description	Quantity
SA198384	SA 10E949W717G3	1.000 EA
RA185752	RA 10E949W717G3	1.000 EA
12CB1003A02	CONDUIT BOX MACH. GROUP C MTRS	1.000 EA
10XN3118K24	5/16-18 X 1.50" HEX HD, GRADE 5	4.000 EA
HW1001A31	LOCKWASHER 5/16, ZINC PLT.591 OD, .319 I	4.000 EA
WD1000B19	TERMINAL BURNDY L250HP	1.000 EA
10XN3816K12	3/8-16 X 3/4 HEX HD CAP GRADE 5	1.000 EA
HW1001A38	LOCKWASHER 3/8, ZINC PLT .688 OD, .382 I	1.000 EA
10EP1701A25P	FR ENDPLATE, MACH W/PRIMER	1.000 EA
HW4505A02	BREATHER/DRAIN-EXP PROOF-.250-18 PTF AIS	1.000 EA
HW3023E06	.125 X .625 SPIRAL SPRING PIN	1.000 EA
HA3050A03	3/8-16 X 2.25" GRADE 8 BOLT	4.000 EA
HW1001A38	LOCKWASHER 3/8, ZINC PLT .688 OD, .382 I	4.000 EA
HW5100A11	W3917-042 WVY WSHR (WB)	1.000 EA
10XN2520K40	1/4-20 X 2-1/2 HEX HD CAPSCREW, GRADE 5,Z	4.000 EA
HW1001A25	LOCKWASHER 1/4, ZINC PLT .493 OD, .255 I	4.000 EA
10EP1710A09P	FACE MTD. EP MACH XPFC W/HW4505A02 W/PRI	1.000 EA
HW4505A02	BREATHER/DRAIN-EXP PROOF-.250-18 PTF AIS	1.000 EA
HW3023E06	.125 X .625 SPIRAL SPRING PIN	1.000 EA
HA3050A03	3/8-16 X 2.25" GRADE 8 BOLT	4.000 EA
HW1001A38	LOCKWASHER 3/8, ZINC PLT .688 OD, .382 I	4.000 EA
HA2067A01	ALUM SLINGER (AUTO)	1.000 EA
80XN1032A06	10-32 X 3/8 SET SC HEX SOCK	2.000 EA
10FH1008A01	310 FAN HOUSING X-PROOF MACH.	1.000 EA

Parts List (continued)		
Part Number	Description	Quantity
WD4100A42	CAPLUG BPF-3/4, FOR 1/2" NPT OR 3/4 HOLE	1.000 EA
10XN3118K12	5/16-18 X .75 GRADE 5, ZINC PLATED	3.000 EA
HW1001A31	LOCKWASHER 5/16, ZINC PLT.591 OD, .319 I	3.000 EA
12CB1502A01	CONDUIT BOX LID MACH. GROUP C MTRS	1.000 EA
84XN5013J32	SOCKET HD.CAP SCR,1/2-13 X 2"LG,ALLOY ST	10.000 EA
HW1001A50	LOCKWASHER 1/2, ZINC PLT.,.879 OD, .509 I	10.000 EA
HW2501H28	KEY, 1/2 SQ X 3.250	1.000 EA
LB1115N	LABEL,LIFTING DEVICE (ON ROLLS)	1.000 EA
LB1081C	ALUM XP CAUTION LABEL (COL PLANT ONLY-	1.000 EA
MN416A01	TAG-INSTAL-MAINT no wire (1200/bx) 11/14	1.000 EA
WD4100A03	DE-750 HEYCO PLUG 62MP0750 MICRO PLASTIC	1.000 EA
HW4500A20	1/8NPT SL PIPE PLUG	2.000 EA
MJ1000A02	GREASE, POLYREX EM EXXON (USe 4824-15A)	0.130 LB
HW4500A20	1/8NPT SL PIPE PLUG	2.000 EA
09FN3001C02	EXTERNAL FAN, PLASTIC	1.000 EA
HW2500A25	WOODRUFF KEY USA #1008 #BLOW CARBON STEE	1.000 EA
51XB1214A20	12-14X1.25 HXWSSLD SERTYB	1.000 EA
MG1025G05	WILKOFASST, 789.227, MED. GRAY CHAR. MET.	0.125 GA
85XU0407S04	4X1/4 U DRIVE PIN STAINLESS	6.000 EA
LB1119N	WARNING LABEL	1.000 EA
LC0145B01	CONNECTION LABEL	1.000 EA
NP0977XPSLEV	SS XP UL CSA-EEV CC CL-I GP-C&D	1.000 EA
14PA1000	PACKAGING 314 GROUP COMBINED PRINT	1.000 EA

AC Induction Motor Performance Data

Record # 35478 - Typical performance - not guaranteed values

Winding: 10WGW717-R022	Type: 1050M	Enclosure: XPFC
-------------------------------	--------------------	------------------------

Nameplate Data				460 V, 60 Hz: High Voltage Connection	
Rated Output (HP)	25//20			Full Load Torque	74 LB-FT
Volts	230/460//190/380			Start Configuration	direct on line
Full Load Amps	61/30.5//59/29.5			Breakdown Torque	226 LB-FT
R.P.M.	1780//1470			Pull-up Torque	101 LB-FT
Hz	60//50	Phase	3	Locked-rotor Torque	137 LB-FT
NEMA Design Code	B	KVA Code	G	Starting Current	188 A
Service Factor (S.F.)	1.15			No-load Current	11.9 A
NEMA Nom. Eff.	93.6	Power Factor	82	Line-line Res. @ 25°C	0.286 Ω
Rating - Duty	40C AMB-CONT			Temp. Rise @ Rated Load	51°C
S.F. Amps				Temp. Rise @ S.F. Load	62°C
				Locked-rotor Power Factor	33
				Rotor inertia	3.96 LB-FT ²

Load Characteristics 460 V, 60 Hz, 25 HP

% of Rated Load	25	50	75	100	125	150	S.F.
Power Factor	47	69	78	82	84	84	83
Efficiency	90.2	93.4	93.9	93.6	92.9	92	93.2
Speed	1793	1787	1781	1774	1766	1758	1769
Line amperes	13.9	18.4	24.1	30.5	37.5	45.2	34.7

Performance Graph at 460V, 60Hz, 25.0HP Typical performance - Not guaranteed values

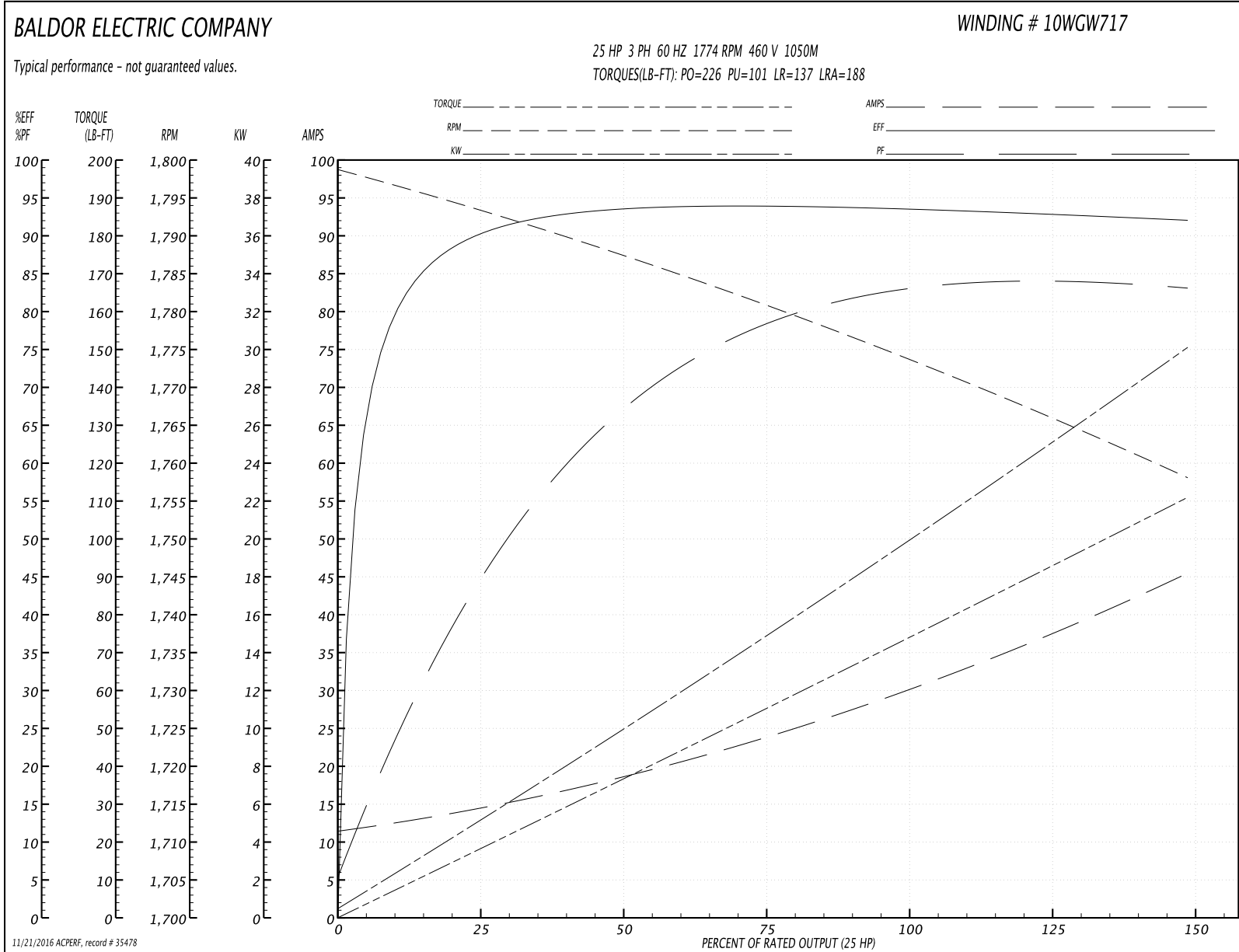

10L YE949

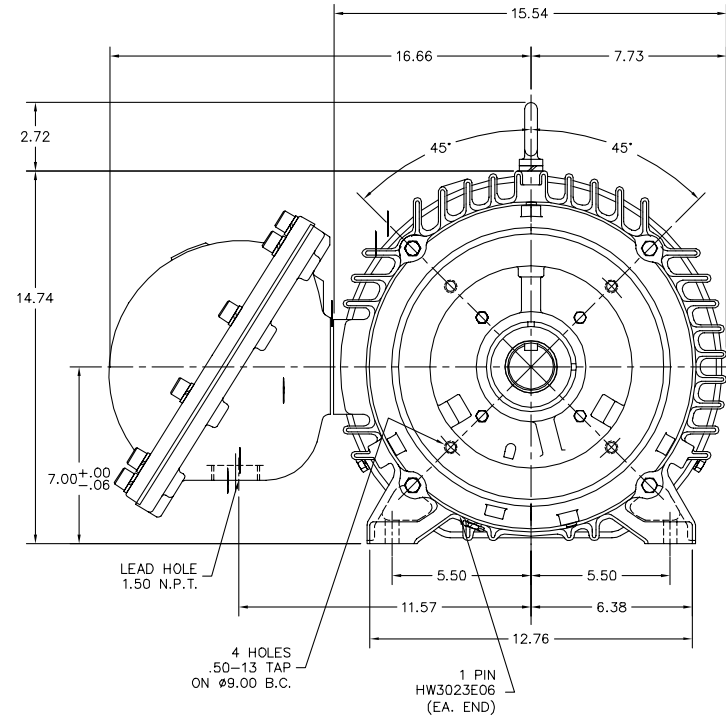
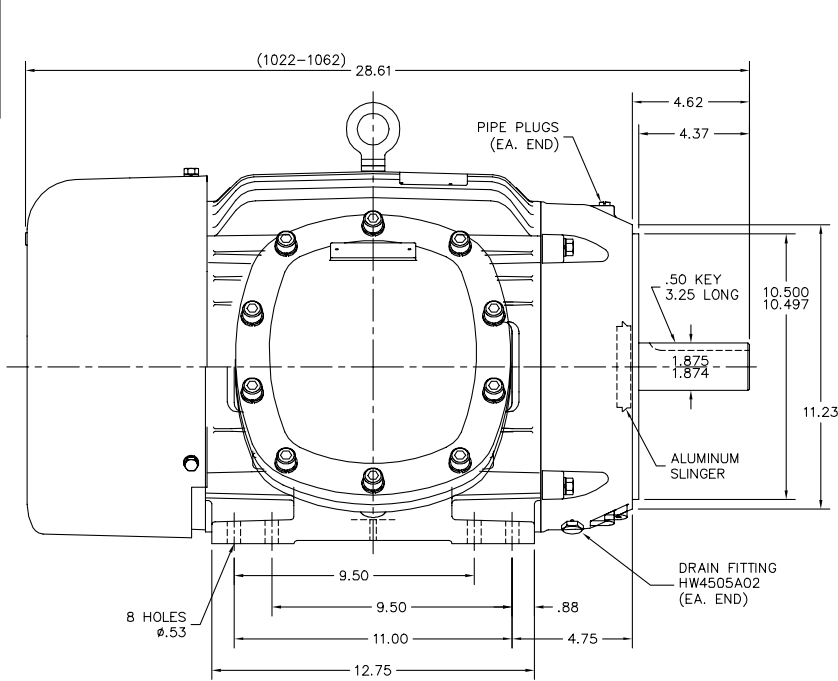

10L YE949

CUSTOMER IS RESPONSIBLE FOR DETERMINING THAT BALDOR'S PRODUCT WILL PERFORM SUITABLY IN THE INTENDED APPLICATION.

REV. DESC: UPDATE STACK RANGES TO (1022-1062)		
REV. LTR: D	VERSION: 02	TDR: 000000579194
FILE: \AAA\00076\041	REVISED: 03:39:56 02/09/2011	BY: ENTYLLO
MTL: -		

BALDOR
 HORZ XPFC 284-6TC CL1, GRP. C&D ONLY, DRILL RIG
 SH 1 of 1

CD0005



LOW VOLTAGE
(2Y)



HIGH VOLTAGE
(1Y)

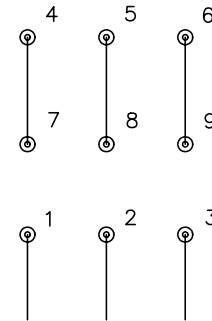

NOTES:

1. INTERCHANGE ANY TWO LINE LEADS TO REVERSE ROTATION.
2. OPTIONAL THERMOSTATS ARE PROVIDED WHEN SPECIFIED.
3. ACTUAL NUMBER OF INTERNAL PARALLEL CIRCUITS MAY BE A MULTIPLE OF THOSE SHOWN ABOVE.
4. LEAD COLORS ARE OPTIONAL. LEADS MUST ALWAYS BE NUMBERED AS SHOWN.

REV. DESC: REVISE TO SHOW OPTIONAL COLORS			
REV. LTR: E	BY: JLP	REVISED: 01/19/99 10:15	TDR: 0171435
90000		FILE: AAA00005140	MDL: -
		MTL: -	

BALDOR ELECTRIC Co.

3PH, DV, 9 LEADS

CD0005