

BALDOR® • **RELIANCE**

Product Information Packet

ECP2276T

7.5HP, 1180RPM, 3PH, 60HZ, 254T, 0954M, TEFC, F

Part Detail							
Revision:	AF	Status:	PRD/A	Change #:		Proprietary:	No
Type:	AC	Prod. Type:	0954M	Elec. Spec:	09WGX827	CD Diagram:	CD0005
Enclosure:	TEFC	Mfg Plant:		Mech. Spec:	09J371	Layout:	09LYJ371
Frame:	254T	Mounting:	F1	Poles:	06	Created Date:	08-29-2010
Base:	RG	Rotation:	R	Insulation:	F	Eff. Date:	10-26-2016
Leads:	9#12					Replaced By:	
Literature:		Elec. Diagram:					

Nameplate NP3241									
CAT.NO.	ECP2276T	P/N		ENCLOSURE	TEFC				
SPEC.	09J371X827	CC	010A	FRAME	254T	S/N			
HP	7.5	CLASS	F	HZ	60	DES	A		
RPM	1180	RPM MAX	1800	PH	3	KVA-CODE	J		
VOLT	230/460	MOTOR WEIGHT	302						
AMP	21.4/10.7	SER.F.	1.15	PF	71	ODE BRG	6309	DE BRG	6309
RATING	40C AMB-CONT	NEMA-NOM-EFF	91	GREASE	POLYREX EM				
				INV.TYPE	PWM				
TEMP CODE	T3C	INVERTER-TEMP-CODE	180						
TEMP =	160	C HP FR	60	C HP TO	90				
CT HZ FROM	1.0	CT HZ TO	60						
HTR-VOLTS		HTR-AMPS		HTR-WATTS		MAX. SPACE HEATER TEMP.		VT HZ FROM	0
								VT HZ TO	60

Parts List		
Part Number	Description	Quantity
SA202252	SA 09J371X827	1.000 EA
RA189533	RA 09J371X827	1.000 EA
09FN3001D01	EXTERNAL FAN, PLASTIC	1.000 EA
09CB1002A12P	KOBX W/1.25 NPT LEAD HOLE & 2.38 MTG HOL	1.000 EA
09GS1010	GASKET, DWG, LEADWIRE SEPERATOR	1.000 EA
10XN2520K12	1/4-20 X.75 GRD 5	4.000 EA
HW1001A25	LOCKWASHER 1/4, ZINC PLT .493 OD, .255 I	4.000 EA
WD1000B16	T&B CX70TN TERMINAL	1.000 EA
10XN2520K08	1/4-20 X .50 GRADE #5, STL, ZINC PLATE	1.000 EA
HW1001A25	LOCKWASHER 1/4, ZINC PLT .493 OD, .255 I	1.000 EA
HA3400A39	STUD- 3/8-16 X 6.19 OAL HEX WELKER	4.000 EA
HW1001A38	LOCKWASHER 3/8, ZINC PLT .688 OD, .382 I	4.000 EA
HW4600B44	V-RING SLINGER 1.500 X 1.810 X .28 VITON	1.000 EA
HW4600B44	V-RING SLINGER 1.500 X 1.810 X .28 VITON	1.000 EA
HA4017A08	.125X3.50 GREASER EXTEN.	1.000 EA
HA4017A02	.125X2.50 GREASER EXTENS.F/S	1.000 EA
HW4019A01	PIPE COUPLING 1/8 NPT,STEEL,ZINC COATING	1.000 EA
HW4500A20	1/8NPT SL PIPE PLUG	1.000 EA
HW5100A11	W3917-042 WVY WSHR (WB)	1.000 EA
10XN2520K36	1/4-20 X 2.25" HX HD SCRWGRADE 5, ZINC P	4.000 EA
09EP1118A38P	PUEP MACH,309 BRG,PLS GRSR,RLF,EPOXY PRI	1.000 EA
09FH1000	FAN COVER,CAST W/E-COAT	1.000 EA
10XN3816K28	3/8-16 X 1.75 HEX HD CAP SCREW, GRADE 5	4.000 EA
HW1001A38	LOCKWASHER 3/8, ZINC PLT .688 OD, .382 I	4.000 EA

Parts List (continued)		
Part Number	Description	Quantity
HW4500A20	1/8NPT SL PIPE PLUG	1.000 EA
10XN2520K36	1/4-20 X 2.25" HX HD SCRWGRADE 5, ZINC P	4.000 EA
HW1001A38	LOCKWASHER 3/8, ZINC PLT .688 OD, .382 I	4.000 EA
XY3816A12	3/8-16 FINISHED NUT	4.000 EA
12CB1503A01P	KOLD MACH, W/LIP & EPOXY PRIMER	1.000 EA
12GS1002	GASKET, CONDUIT BOX LID, NEOP	1.000 EA
10XN3118K16	5/16-18 X 1' GRADE #5, STL, ZINC PLATE	2.000 EA
HW1001A31	LOCKWASHER 5/16, ZINC PLT.591 OD, .319 I	2.000 EA
HW2501G25	KEY, 3/8 SQ X 2.875	1.000 EA
MJ5001A27	32220KN GRAY SEALER *MIN BUY 4 QTS=1GAL	0.031 QT
MJ5001A14	DYNAPRO SEAL, CP MOTORS VC#2508050 (603	0.033 EA
09EP1118A37GP6	FREP MACH, 309 BRG. EPOXY PRIMER	1.000 EA
MJ5002A01	SILICON RUBBER SEALANT, 732CL 10.3 OZ TU	0.025 EA
85XU0407S04	4X1/4 U DRIVE PIN STAINLESS	2.000 EA
LB1115N	LABEL,LIFTING DEVICE (ON ROLLS)	1.000 EA
MN416A01	TAG-INSTAL-MAINT no wire (1200/bx) 11/14	1.000 EA
LC0005E02	SPL CONN.DIA./WARN.LABEL(LC0005/LB1119)	1.000 EA
NP3241	SS SUPER-E INV UL CSA-EEV PREM CC	1.000 EA
LB1449	DIV-2/NEC WARNING LABEL	1.000 EA
40PA1005	PACKAGING GROUP, 09 STD	1.000 EA
LB1002N	LABEL,MARINE DUTY (ON ROLLS)	1.000 EA
HW4500A17	317400 ALEMITE GREASE RELIEF	1.000 EA
HW4500A21	1618BALEMITE FITTING 825 UNIVERSAL	1.000 EA
HA4054	SHORT T-DRAIN FITTING, .125" N.P.T.	1.000 EA

Product Information Packet: ECP2276T - 7.5HP,1180RPM,3PH,60HZ,254T,0954M,TEFC,F

HA4051A00	PLASTIC CAP FOR GREASE FITTING	1.000 EA
MJ1000A02	GREASE, POLYREX EM EXXON (USe 4824-15A)	0.080 LB
HW4500A03	GREASE FITTING, .125 NPT 1610(ALEMITE) 8	1.000 EA
HW4500A17	317400 ALEMITE GREASE RELIEF	1.000 EA
HA4054	SHORT T-DRAIN FITTING, .125" N.P.T.	1.000 EA
HA4051A00	PLASTIC CAP FOR GREASE FITTING	1.000 EA
HW2500A25	WOODRUFF KEY USA #1008 #BLOW CARBON STEE	1.000 EA
51XB1214A20	12-14X1.25 HXWSSLD SERTYB	1.000 EA
MG1025N19	WILKOFAS, 778.50, RELIANCE BLUE-GREEN	0.050 GA

Accessories		
Part Number	Description	Multiplier
09-1309	C FACE KIT	A8

AC Induction Motor Performance Data

Record # 47260 - Typical performance - not guaranteed values

Winding: 09WGX827-R040	Type: 0954M	Enclosure: TEFC
-------------------------------	--------------------	------------------------

Nameplate Data				460 V, 60 Hz: High Voltage Connection	
Rated Output (HP)	7.5			Full Load Torque	32.4 LB-FT
Volts	230/460			Start Configuration	direct on line
Full Load Amps	21.4/10.7			Breakdown Torque	99.2 LB-FT
R.P.M.	1180			Pull-up Torque	39.4 LB-FT
Hz	60	Phase	3	Locked-rotor Torque	57.8 LB-FT
NEMA Design Code	A	KVA Code	J	Starting Current	69.7 A
Service Factor (S.F.)	1.15			No-load Current	5.84 A
NEMA Nom. Eff.	91	Power Factor	71	Line-line Res. @ 25°C	0.89 Ω
Rating - Duty	40C AMB-CONT			Temp. Rise @ Rated Load	31°C
S.F. Amps				Temp. Rise @ S.F. Load	36°C
				Rotor inertia	4.34 LB-FT ²

Load Characteristics 460 V, 60 Hz, 7.5 HP

% of Rated Load	25	50	75	100	125	150	S.F.
Power Factor	32	52	63	71	73	75	72
Efficiency	83	89.7	91.5	91.5	91.8	91.2	91.9
Speed	1196	1192	1189	1184	1179	1173	1181
Line amperes	6.34	7.49	8.87	10.7	12.9	15.7	12

Performance Graph at 460V, 60Hz, 7.5HP Typical performance - Not guaranteed values

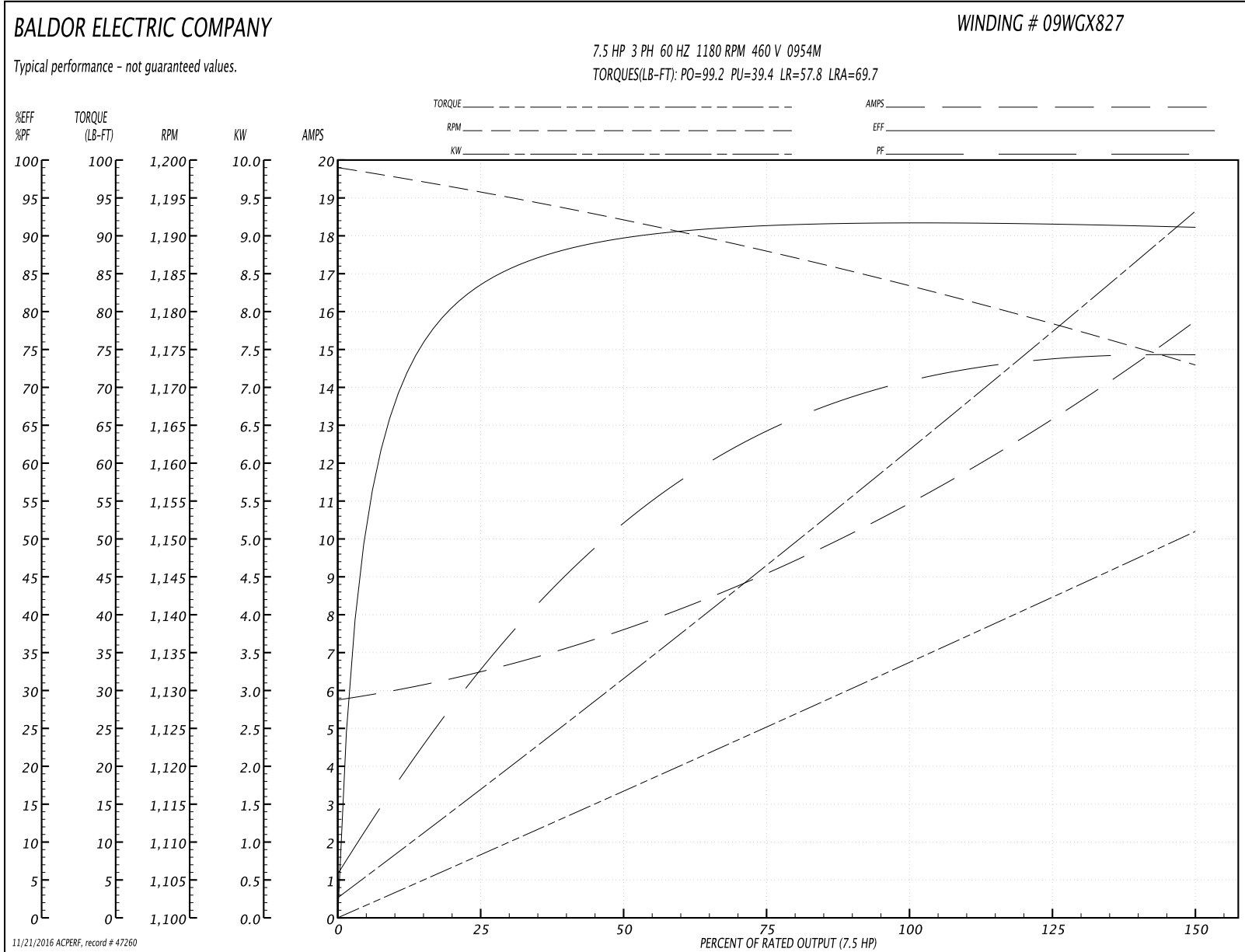

09LYJ371

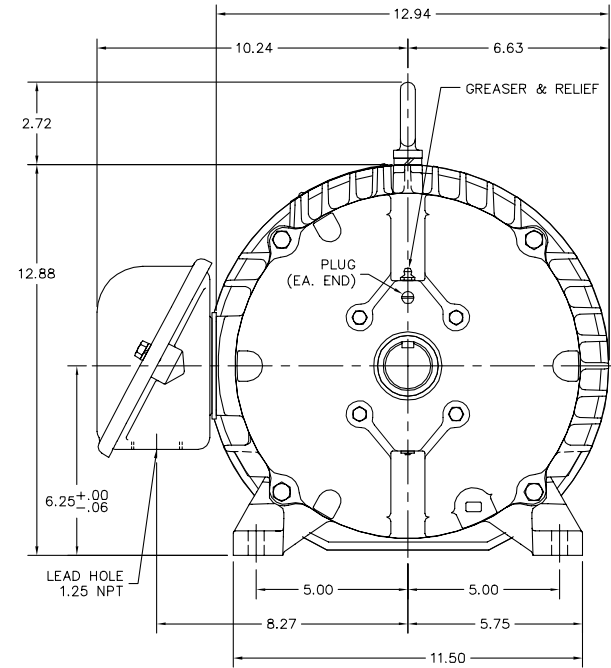
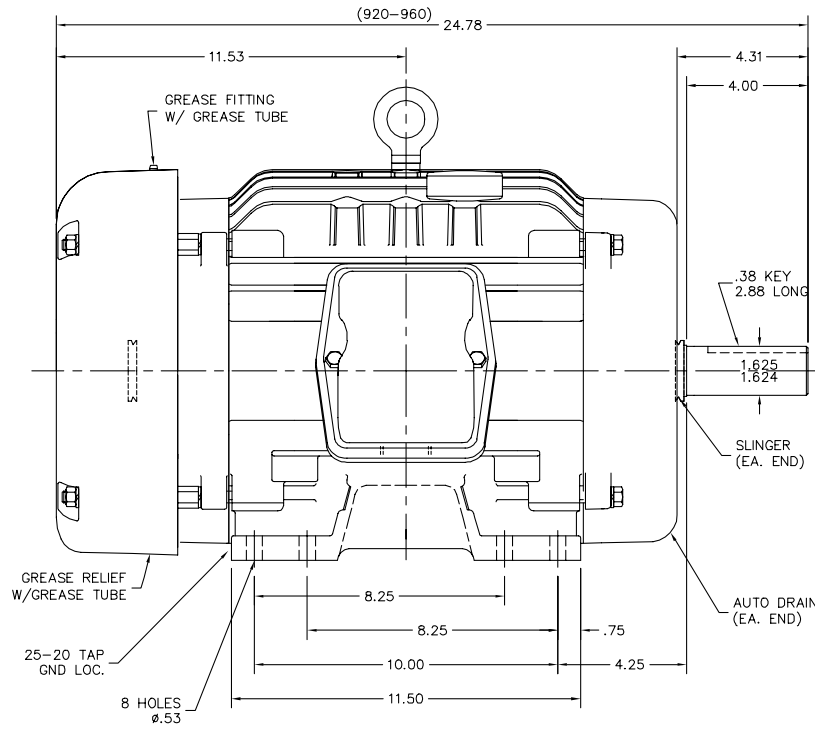

09LYJ371

CUSTOMER IS RESPONSIBLE FOR DETERMINING THAT BALDOR'S PRODUCT WILL PERFORM SUITABLY IN THE INTENDED APPLICATION.

REV. DESC: ADDED GND HOLE TAP SIZE	VERSION: 07	TDR: 000000954909
REV. LTR: G		
FILE: \AAA\00174\539	REVISED: 12:56:55 12/07/2015	BY: ENNINDO
MTL: -		

BALDOR

HORZ TEFC 254-6T ECP W/309 BRGS, PLS GREASING
SH 1 of 1

CD0005



LOW VOLTAGE
(2Y)



LINE

HIGH VOLTAGE
(1Y)

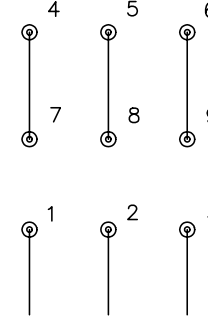

LINE

NOTES:

1. INTERCHANGE ANY TWO LINE LEADS TO REVERSE ROTATION.
2. OPTIONAL THERMOSTATS ARE PROVIDED WHEN SPECIFIED.
3. ACTUAL NUMBER OF INTERNAL PARALLEL CIRCUITS MAY BE A MULTIPLE OF THOSE SHOWN ABOVE.
4. LEAD COLORS ARE OPTIONAL. LEADS MUST ALWAYS BE NUMBERED AS SHOWN.

REV. DESC: REVISE TO SHOW OPTIONAL COLORS			
REV. LTR: E	BY: JLP	REVISED: 01/19/99 10:15	TDR: 0171435
90000		FILE: AAA00005140	MDL: -
		MTL: -	

BALDOR ELECTRIC Co.

3PH, DV, 9 LEADS

CD0005

Marketing maintained PDF of MN416:

<http://www.baldor.com/support/Literature/Load.ashx/MN416?ManNumber=MN416>