

BALDOR® • **RELIANCE**

Product Information Packet

EM7019

1.5//1HP,1760//1460RPM,3PH,60//50HZ,184

Part Detail							
Revision:	B	Status:	PRD/A	Change #:		Proprietary:	No
Type:	AC	Prod. Type:	3526M	Elec. Spec:	35WGM493	CD Diagram:	CD0005
Enclosure:	XPFC	Mfg Plant:		Mech. Spec:	35M526	Layout:	35LYM526
Frame:	184	Mounting:	F1	Poles:	04	Created Date:	08-31-2015
Base:	RG	Rotation:	R	Insulation:	B	Eff. Date:	10-19-2015
Leads:	9#18					Replaced By:	
Literature:		Elec. Diagram:					

Nameplate NP1426XPSLEV	
NO.	[] CC 010A []
SER.	[]
SPEC.	35M526M493G1
CAT.NO.	EM7019
HP	1.5//1 [] T. CODE T3C []
VOLTS	230/460//190/380
AMPS	4.4/2.2//3.8/1.9
RPM	1760//1460
HZ	60//50 [] PH 3 [] CL B []
SER.F.	1.00 [] DES B [] CODE L []
RATING	40C AMB-CONT
FRAME	184 [] NEMA-NOM-EFF 86.5 []
USABLE AT 208V	4.5 [] PF 73 []
BLANK	[]

Parts List		
Part Number	Description	Quantity
SA306782	SA 35M526M493G1	1.000 EA
RA294042	RA 35M526M493G1	1.000 EA
34FN3002B01	EXTERNAL FAN, PLASTIC, .637/.639 HUB W/	1.000 EA
35CB3001A01SP	EXPL CONDUIT BOX, MACH, 1/2" PIPE TAP LE	1.000 EA
11XW1032G06	10-32 X .38, TAPTITE II, HEX WSHR SLTD U	1.000 EA
HW3001B01	BRASS CUP WASHER, FOR #8 SCREW	1.000 EA
35EP3700A01SP	FR ENDPLATE, XPFC	1.000 EA
HW5100A03SP	WAVY WASHER (W1543-017)	1.000 EA
35EP3701A01	PU ENDPLATE, XPFC - 205 BRG	1.000 EA
XY3118A12	5/16-18 HEX NUT DIRECTIONAL SERRATION	4.000 EA
51XB1214A16	12-14X1.00 HXWSSLD SERTYB	1.000 EA
35FH4005A01SP	IEC FH NO GREASER W/PRIMED	1.000 EA
51XW1032A06	10-32 X .38, TAPTITE II, HEX WSHR SLTD S	3.000 EA
35CB3500A01SP	CONDUIT BOX LID, MACH	1.000 EA
51XN2520A16	SCREW, HEX WS SLT, ZN, 1/4-20 X 1.00	4.000 EA
HW2501D13	KEY, 3/16 SQ X 1.375	1.000 EA
HA7000A01	KEY RETAINER 7/8" DIA SHAFT	1.000 EA
85XU0407S04	4X1/4 U DRIVE PIN STAINLESS	6.000 EA
MJ1000A02	GREASE, POLYREX EM EXXON (USe 4824-15A)	0.050 LB
MG1025G29	WILKOFASST, 789.229, DARK CHARCOAL GRAY	0.017 GA
HA3104A08	THRUBOLT-5/16-18X9.375 X X	4.000 EA
LB1119N	WARNING LABEL	1.000 EA
LC0145B01	CONNECTION LABEL	1.000 EA
NP1426XPSLEV	SS XP UL CSA-EEV CC CL-I GP-D	1.000 EA

Parts List (continued)		
Part Number	Description	Quantity
36PA1001	PKG GRP, PRINT PK1017A06	1.000 EA
MN416A01	TAG-INSTAL-MAINT no wire (1000/bx) 11/14	1.000 EA

AC Induction Motor Performance Data

Record # 35582 - Typical performance - not guaranteed values

Winding: 35WGM493-R009	Type: 3526M	Enclosure: XPFC
-------------------------------	--------------------	------------------------

Nameplate Data				440 V, 50 Hz: High Voltage Connection	
Rated Output (HP)	1.5//1			Full Load Torque	3.56 LB-FT
Volts	230/460//220/440			Start Configuration	direct on line
Full Load Amps	4.4/2.2//4.8/2.4			Breakdown Torque	24.6 LB-FT
R.P.M.	1760//1460			Pull-up Torque	13.7 LB-FT
Hz	60//50	Phase	3	Locked-rotor Torque	19.5 LB-FT
NEMA Design Code	B	KVA Code	L	Starting Current	21.1 A
Service Factor (S.F.)	1			No-load Current	2.09 A
NEMA Nom. Eff.	86.5	Power Factor	73	Line-line Res. @ 25°C	10.1 Ω
Rating - Duty	40C AMB-CONT			Temp. Rise @ Rated Load	46°C
S.F. Amps				Temp. Rise @ S.F. Load	51°C
				Locked-rotor Power Factor	59.7
				Rotor inertia	0.154 LB-FT ²

Load Characteristics 440 V, 50 Hz, 1 HP

% of Rated Load	25	50	75	100	125	150
Power Factor	19	30	41	51	58	65
Efficiency	60.7	74.3	79.9	82.4	83.3	83.4
Speed	1494	1488	1481	1475	1468	1460
Line amperes	2.1	2.14	2.22	2.35	2.53	2.71

Performance Graph at 440V, 50Hz, 1.0HP Typical performance - Not guaranteed values

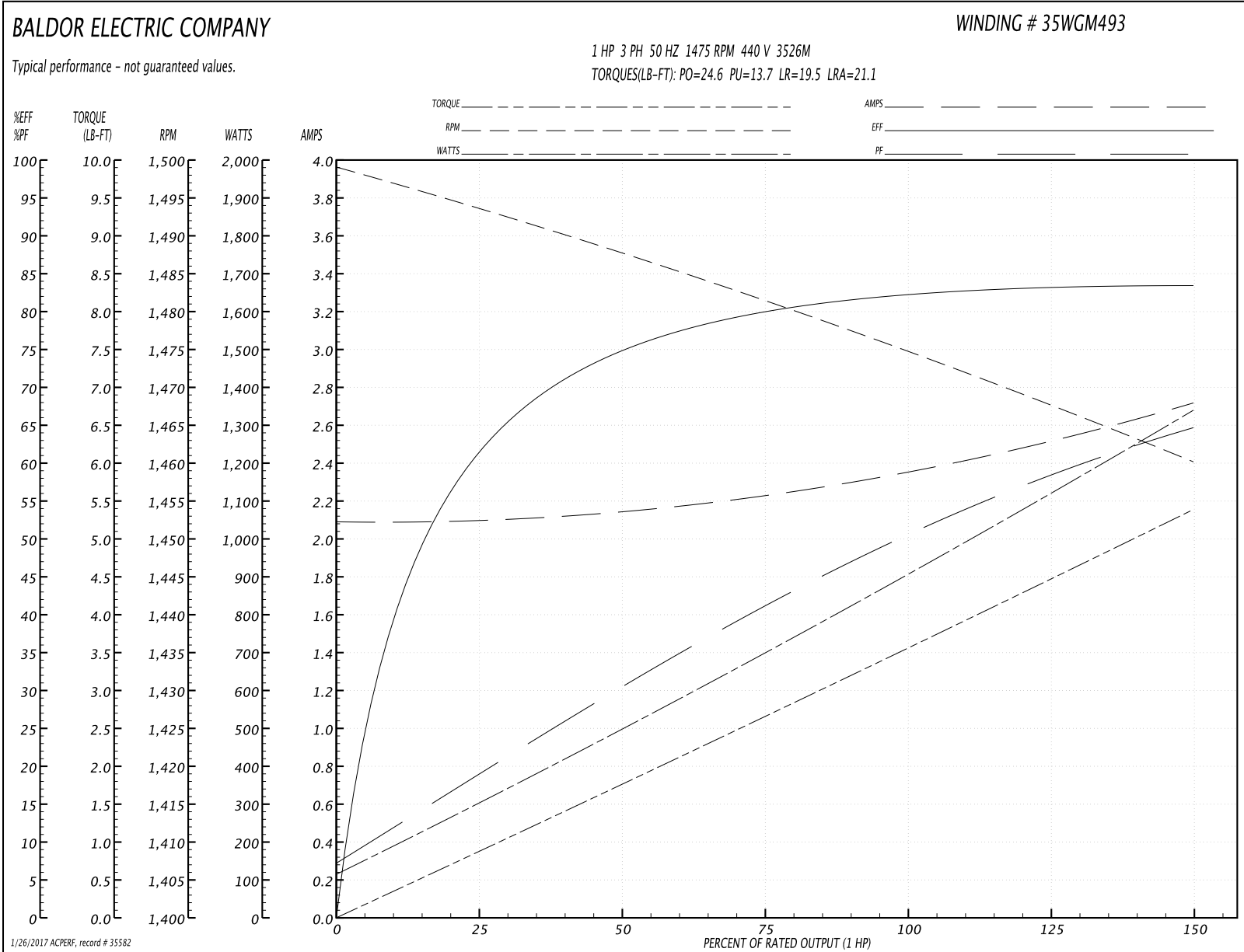

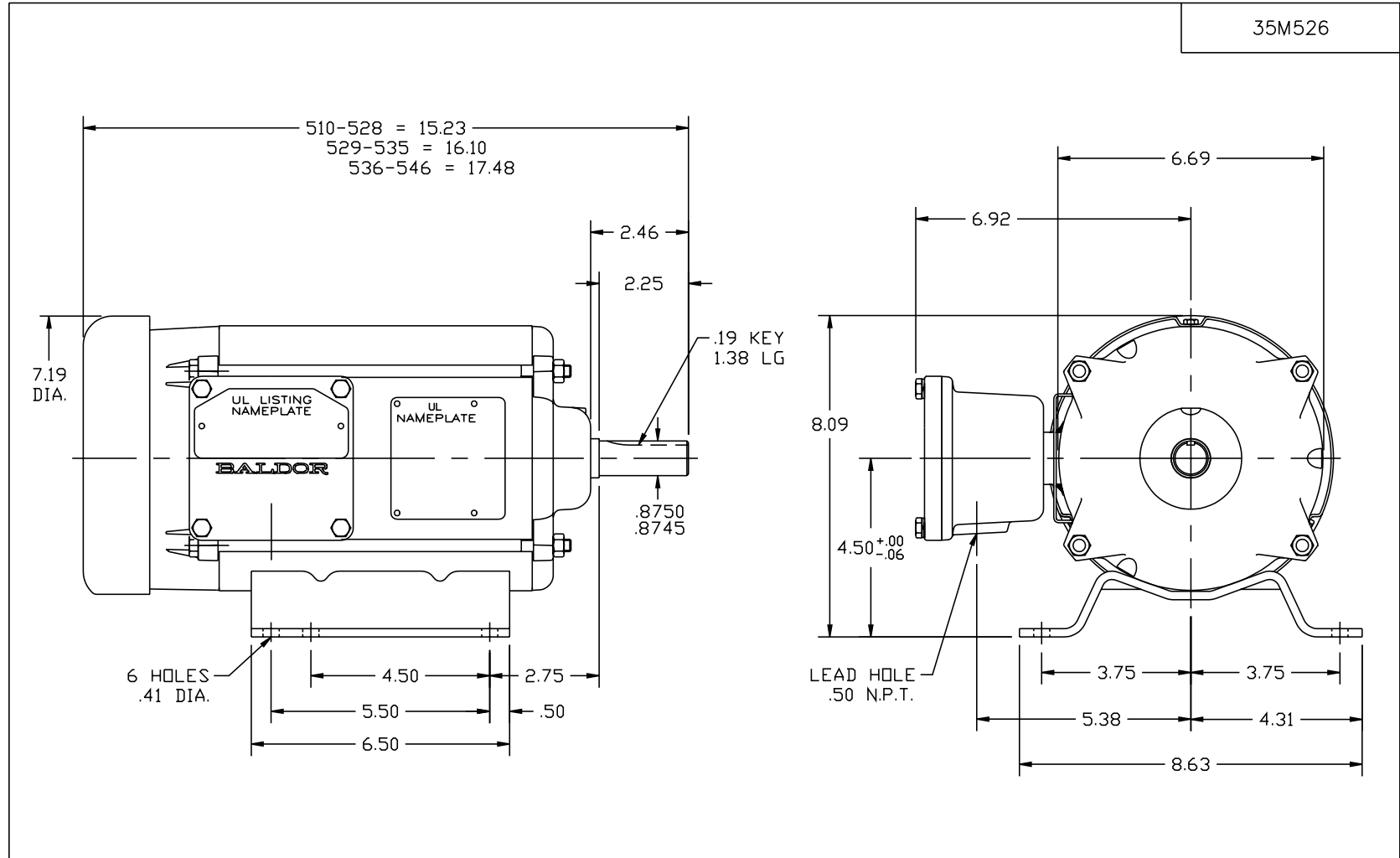

35M526

L CLASS I - GROUP D - CLASS II - GROUPS F & G

CUST. NAME		CUST. P.O.		CERTIFIED BY		MODEL		INSUL		AMB							
H.P.		MTG		TYPE		R.P.M.		VOLTS		ENCL							
PHASE		FREQ		FRAME		<h1>BALDOR ELECTRIC Co.</h1> <p>STD HORZ 182-4 TEFC X35M CL I-GP D-CL II-GP F&G</p>											
REMARKS:																	
REV:	A	LEAD HOLE CALL OUT WAS .75"															
9ZGWG		SCALE: .3		BY: JER		REVISED: 10/22/94											
		FILE: AAA00013687		TDR: 0064127													

35M526

CD0005



LOW VOLTAGE
(2Y)

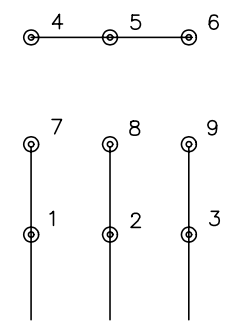

LINE

HIGH VOLTAGE
(1Y)

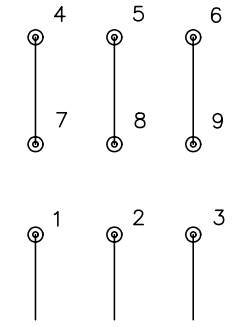

LINE

NOTES:

1. INTERCHANGE ANY TWO LINE LEADS TO REVERSE ROTATION.
2. OPTIONAL THERMOSTATS ARE PROVIDED WHEN SPECIFIED.
3. ACTUAL NUMBER OF INTERNAL PARALLEL CIRCUITS MAY BE A MULTIPLE OF THOSE SHOWN ABOVE.
4. LEAD COLORS ARE OPTIONAL. LEADS MUST ALWAYS BE NUMBERED AS SHOWN.

REV. DESC: REVISE TO SHOW OPTIONAL COLORS			
REV. LTR: E	BY: JLP	REVISED: 01/19/99 10:15	TDR: 0171435
90000		FILE: AAA00005140	MDL: -
		MTL: -	

BALDOR ELECTRIC Co.

3PH, DV, 9 LEADS

CD0005