

BALDOR® • RELIANCE

Product Information Packet

EM7310T-I

60//50HP,3560//2960RPM,3PH,60//50HZ,364T

Part Detail							
Revision:	J	Status:	PRD/A	Change #:		Proprietary:	No
Type:	AC	Prod. Type:	A36048M	Elec. Spec:	A36WG0796	CD Diagram:	416820-002
Enclosure:	TEFC	Mfg Plant:		Mech. Spec:		Layout:	611742-675-SH1
Frame:	364TS	Mounting:	F1	Poles:	02	Created Date:	04-09-2014
Base:		Rotation:	R	Insulation:	F	Eff. Date:	11-18-2016
Leads:	3#4,6#6					Replaced By:	
Literature:		Elec. Diagram:					

Nameplate 000613006PC

CLASS I GROUP	C D X
CLASS II GROUP	X X X
OPERATING TEMP CODE	T3C

Nameplate NP2293L			
CAT.NO.	EM7310T-I	SPEC NO.	P36G4708
HP	60//50	PHASE	3
RPM	3560//2960	HZ	60//50
VOLTS	230/460//190/380	DESIGN	B
AMPS	135/67.3//137/68.3	TYPE	P
DRIVE END BEARING	65BC03JPP30A	AMB	40
OPP D.E. BEARING	65BC03JPP30A	SF	1.15
SER.NO.		DUTY	CONT
		ENCL	TEFC
		INSUL.CLASS	F
		CODE	F
		NEMA-NOM-EFFICIENCY	93.6
		NEMA MG-1 PT 5, IP55 OVER TEMP PROT 2	
	SUIT FOR 208V/147 AMPS, 55C AMB @ 1.0SF		MOTOR WEIGHT
			830
		FRAME	364TS

Parts List		
Part Number	Description	Quantity
SA279193	SA P36G4708	1.000 EA
RA265718	RA P36G4708	1.000 EA
000613006PC	N/P U/L (REL QTY 500)	1.000 EA
NP2293L	BALDOR RELIANCE INDUST. MTR,SS,CSA-C US,	1.000 EA
000692000VD	LABEL WARNING	1.000 EA
421948032	LABEL, MYLAR	1.000 EA
603284001S	SLGR - 360	1.000 EA
609158001B	SLGR - 360	1.000 EA
004824015A	GREASE POLYREX EM	0.544 LB
032018008AK	HHCS 1/4-20X1 PLATED	4.000 EA
032018018CK	HHCS 3/8-16X2-1/4 PLTD.	2.000 EA
032130020DB	HSKCS 1/2-13X2-1/2 PLTD.	4.000 EA
034017012AB	LCKW 1/4 STD. PLATED	4.000 EA
034017014AB	LCKW 3/8 STD. PLATED	2.000 EA
034017016AB	LCKW 1/2" PLATED	4.000 EA
034180012DA	KEY 1X4X1/4X1-1/2 L	1.000 EA
034530056AC	P/NIP 1/8X7L GALV-365	1.000 EA
034690001AB	SQHDPLG, COND	1.000 EA
034690002AB	"unbulked" PPLG 1/4" PLTD.	1.000 EA
078559001A	+FANCV - 360	1.000 EA
087793050B	BRKT 360 087793050WCB	1.000 EA
410700004F	WSHR	1.000 EA
415072001B	CLAMP	1.000 EA
415096002A	CPLG 1/8 HEX TYPE	1.000 EA

Parts List (continued)		
Part Number	Description	Quantity
702675001C	FAN 360	1.000 EA
032018018CK	HHCS 3/8-16X2-1/4 PLTD.	2.000 EA
032130020DB	SHSCS 1/2-13X2-1/2 PLTD.	4.000 EA
034017014AB	LCKW 3/8 STD. PLATED	2.000 EA
415045002E	SLGR	1.000 EA
034017016AB	LCKW 1/2" PLATED	4.000 EA
034690001AB	SQHDPLG, COND	1.000 EA
034690002AB	"unbulked" PPLG 1/4" PLTD.	1.000 EA
087793050A	BRKT 360 087793050WCB	1.000 EA
032018008DK	HHCS 1/2-13X1 PLATED	1.000 EA
032130012EB	SHSCS 5/8-11X1-1/2 PLTD.	8.000 EA
032130014CB	SHSCS 3/8-16X1-3/4 PLTD.	4.000 EA
034017018AB	LCKW 5/8"	8.000 EA
LB1073	ALUM XP CAUTION LABEL	1.000 EA
85XU0407S04	4X1/4 U DRIVE PIN STAINLESS	2.000 EA
LB1073	ALUM XP CAUTION LABEL	1.000 EA
406099000A	PLUG - FAN COVER 320-440	1.000 EA
MG1025G05	WILKOFAS, 789.227, MED. GRAY CHAR. MET.	0.250 GA
033775004EA	DRSCR #6-1/4 304 S.S.	8.000 EA
034180016GA	KEY 1/2X1/2X2 L	1.000 EA
14PA1000	PACKAGING 314 GROUP COMBINED PRINT	1.000 EA
034017014AB	LCKW 3/8 STD. PLATED	4.000 EA
16CB1501A01	CONDUIT BOX LID MACH.GRP C MTRS 16CB1501	1.000 EA
16CB1001A01	CONDUIT BOX MACH. GROUP C MTRS	1.000 EA

611742-675-SH1

DUTY MASTER ALTERNATING CURRENT MOTORS

ENCLOSURE: TOTALLY ENCLOSED
 UNDERWRITERS LISTED MOTOR
 MOUNTING: FOOT

SQUIRREL-CAGE INDUCTION

FRAMES E364T-E365TS

COOLING: FAN COOLED
 BOLTED ON CONDUIT BOX

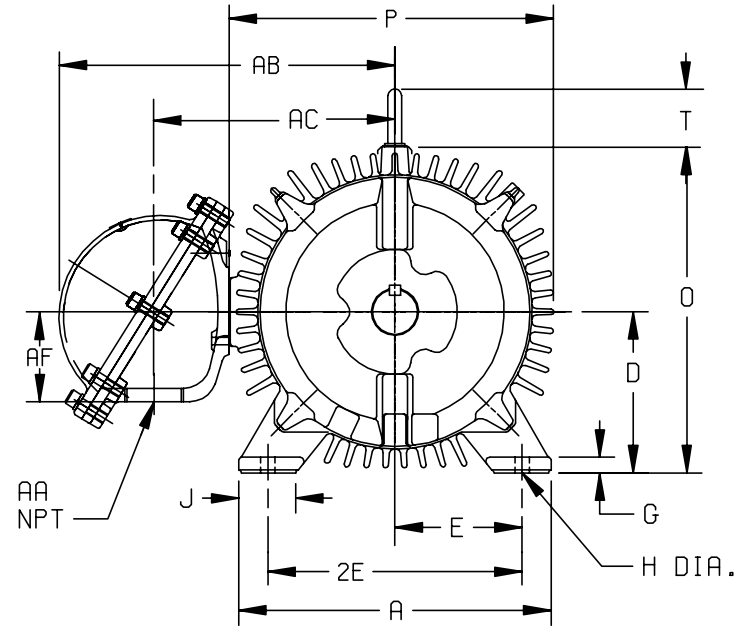
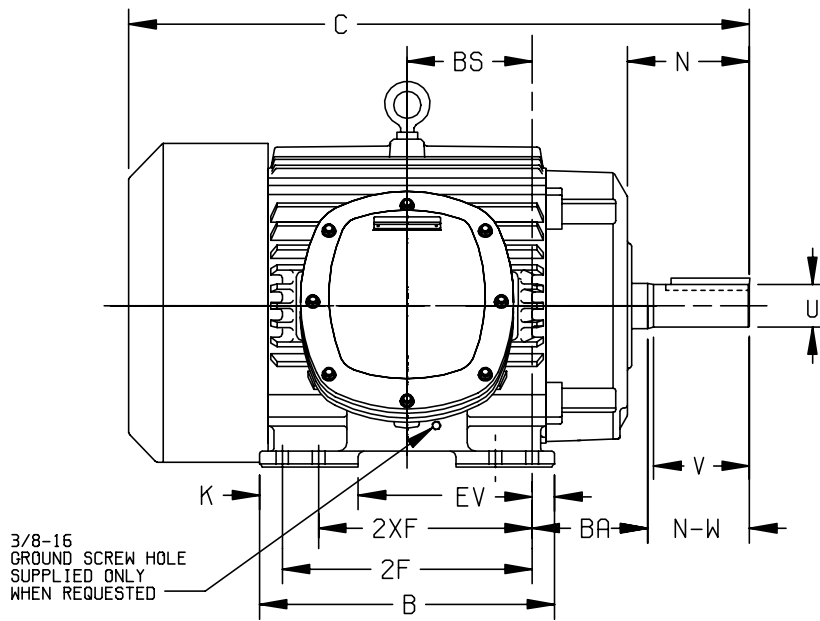

DIMENSIONS ARE IN INCHES; SEE SHEET 2 FOR DIMENSIONS IN MILLIMETERS

FRAME	A	D(1)	E	G	H	J	K	O	P	T	XP TERMINAL BOX					EV
											AA	AB	AC	AF	BA	
E364T-365TS	17.00	9.00	7.00	.88	.69	2.75	4.00	19.11	20.25	2.94	3	20.88	15.17	5.40	5.88	1.38

FRAME SIZE	C	BS	B	2F	(3) 2XF	N	SHAFT AND KEY					WEIGHT LBS. (4)
							N-W(5)	U(2)	V	SQ.	LGTH.	
E364T	33.44	6.12	15.00	---	11.25	6.00	5.88	2.375	5.62	.625	4.25	910
E364TS	31.31	6.12	15.00	---	11.25	3.88	3.75	1.875	3.50	.500	2.00	904
E365T	33.44	6.12	15.00	12.25	---	6.00	5.88	2.375	5.62	.625	4.25	950
E365TS	31.31	6.12	15.00	12.25	---	3.88	3.75	1.875	3.50	.500	2.00	944

- (1) "D" VARIES +.00, -.06.
- (2) "U" VARIES +.000, -.001.
- (3) ALL FRAMES HAVE EIGHT MOUNTING HOLES FOR DUAL MOUNTING.
- (4) MOTOR WEIGHTS MAY VARY BY 15% DEPENDING UPON RATING.
- (5) "N-W" VARIES +.00, -.25.

CONDUIT BOX LOCATED ON OPPOSITE SIDE WHEN F-2,W-1, W-4,W-5,W-7, OR C-1 MOUNTING IS SPECIFIED.

IF MOUNTING CLEARANCE DETAILS ARE REQUIRED, CONSULT FACTORY.

MAXIMUM PERMISSIBLE SHAFT RUNOUT WHEN MEASURED AT END OF STD. SHAFT EXTENSION IS .003

CUSTOMER IS RESPONSIBLE FOR DETERMINING THAT BALDOR'S PRODUCT WILL PERFORM SUITABLY IN THE INTENDED APPLICATION.

REV. DESC: NEW FOR 360 FRAME STOCK XP MOTORS		
REV. LTR: -	VERSION: 00	TDR: 000000869122
FILE: \RAG\00020\724	REVISED: 10:25:23 08/28/2014	BY: RAGFBR
MTL: -	⊙ ⊚	

BALDOR

DIM SHT FCXP FT E360T BOLTED ON C/B W/3"NPT GROUP C&D

SH 1 of 1

611742-675-SH1

611742-675-SH2

DUTY MASTER ALTERNATING CURRENT MOTORS

ENCLOSURE: TOTALLY ENCLOSED
 UNDERWRITERS LISTED MOTOR
 MOUNTING: FOOT

SQUIRREL-CAGE INDUCTION

FRAMES E364T-E365TS

COOLING: FAN COOLED
 BOLTED ON CONDUIT BOX

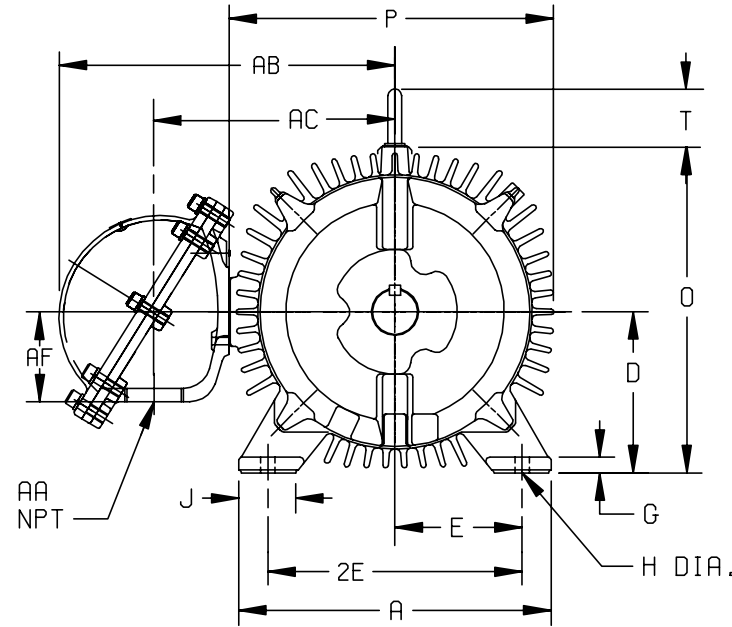
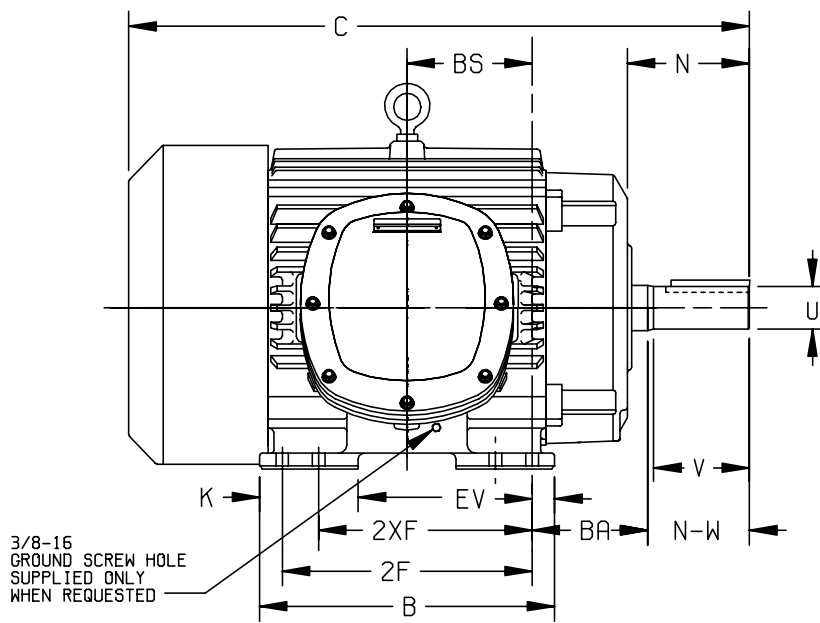

DIMENSIONS ARE IN INCHES; SEE SHEET 2 FOR DIMENSIONS IN MILLIMETERS

FRAME	A	D(1)	E	G	H	J	K	O	P	T	XP TERMINAL BOX				BA	EV
											AA	AB	AC	AF		
E364T-365TS	431.8	228.6	177.8	22.4	17.5	69.9	101.6	469.9	514.4	74.7	76.2	530.4	385.3	137.2	149.4	35.1

FRAME SIZE	C	BS	B	2F	(3) 2XF	N	SHAFT AND KEY				WEIGHT LBS. (4)	
							N-W(5)	U(2)	V	SQ.		LGTH.
E364T	849.4	155.4	381.0	---	285.7	152.4	149.4	60.33	142.7	15.88	108.0	412
E364TS	795.3	155.4	381.0	---	285.7	98.6	95.3	47.63	88.9	12.70	50.8	410
E365T	849.4	155.4	381.0	311.1	---	152.4	149.4	60.33	142.7	15.88	108.0	430
E365TS	795.3	155.4	381.0	311.1	---	98.6	95.3	47.63	88.9	12.70	50.8	428

- (1) "D" VARIES +.0, -1.5.
- (2) "U" VARIES +.00, -.03.
- (3) ALL FRAMES HAVE EIGHT MOUNTING HOLES FOR DUAL MOUNTING.
- (4) MOTOR WEIGHTS MAY VARY BY 15% DEPENDING UPON RATING.
- (5) "N-W" VARIES +.0, -6.4.

CONDUIT BOX LOCATED ON OPPOSITE SIDE WHEN F-2,W-1, W-4,W-5,W-7, OR C-1 MOUNTING IS SPECIFIED.

IF MOUNTING CLEARANCE DETAILS ARE REQUIRED, CONSULT FACTORY.

MAXIMUM PERMISSIBLE SHAFT RUNOUT WHEN MEASURED AT END OF STD. SHAFT EXTENSION IS .08.

CUSTOMER IS RESPONSIBLE FOR DETERMINING THAT BALDOR'S PRODUCT WILL PERFORM SUITABLY IN THE INTENDED APPLICATION.

REV. DESC: NEW FOR 360 FRAME STOCK XP MOTORS		
REV. LTR: -	VERSION: 00	TDR: 000000869122
FILE: \RAG\00020\728	REVISED: 10:52:43 08/28/2014	BY: RAGFBR
MTL: -	⊙ ⊐	

BALDOR

DIM SHT FCXP FT E360T BOLTED ON C/B W/3"NPT GROUP C&D

SH 1 of 1

611742-675-SH2

416820-002

A-C MOTOR
 CONNECTION DIAGRAM
 STANDARD 9 LEAD DELTA-CONNECTED

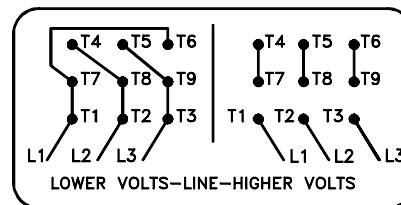
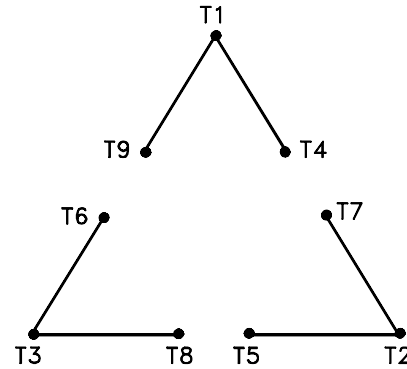

(N.P. 1575-B)

416820-002

REV. DESC: LOADED TO BUS, C/R 335225		
REV. LTR: -	VERSION: 00	TDR: 000000538207
FILE: \MGA\00000\661	REVISED: 10: 47: 51 04/30/2010	
MTL: -	BY: RAGRA	

BALDOR

CONN DIAG - STANDARD 9 LEAD, DELTA-CONNECTED

SH 1 of 1

Marketing maintained PDF of MN408:

<http://www.baldor.com/support/Literature/Load.ashx/MN408?ManNumber=MN408>

Marketing maintained PDF of MN416:

<http://www.baldor.com/support/Literature/Load.ashx/MN416?ManNumber=MN416>