

BALDOR® • *RELIANCE*

Product Information Packet

JMEWDM3558T

2HP, 1755RPM, 3PH, 60HZ, 145JM, 3530M, TEFC, F1

Part Detail							
Revision:	E	Status:	PRD/A	Change #:		Proprietary:	No
Type:	AC	Prod. Type:	3530M	Elec. Spec:	35WGM494	CD Diagram:	CD0005
Enclosure:	TEFC	Mfg Plant:		Mech. Spec:	35SS629	Layout:	35LYSS629
Frame:	145JM	Mounting:	F1	Poles:	04	Created Date:	12-04-2014
Base:	RG	Rotation:	R	Insulation:	F	Eff. Date:	06-08-2016
Leads:	9#18					Replaced By:	
Literature:		Elec. Diagram:					

Nameplate NP1669L										
CAT.NO.	JMEWDM3558T									
SPEC.	35SS629M494G1									
HP	2									
VOLTS	230/460									
AMP	5.8/2.9									
RPM	1755									
FRAME	145JM				HZ	60			PH	3
SER.F.	1.15		CODE	L	DES	B		CLASS	F	
NEMA-NOM-EFF	86.5		PF	73						
RATING	40C AMB-CONT									
CC	010A				USABLE AT 208V			6		
DE	6206				ODE	6203				
ENCL	TEFC		SN							
BLANK										

Parts List		
Part Number	Description	Quantity
SA290725	SA 35SS629M494G1	1.000 EA
RA276881	RA 35SS629M494G1	1.000 EA
34FN3002B01	EXTERNAL FAN, PLASTIC, .637/.639 HUB W/	1.000 EA
NS2512A01	INSULATOR, CONDUIT BOX X	1.000 EA
35CB3010A01W	35 CB .75 NPT @ 6:00, WHITE EPOXY	1.000 EA
35GS1039	05 MOLDED GASKET W/LIP, 1.12 LEAD HOLE,	1.000 EA
51XB1016A08	10-16X 1/2HXWSSLD SERTYB	2.000 EA
HA5027A01	HA4066A01 T-DRAIN X2 BAGGED	1.000 EA
11XW1032G06	10-32 X .38, TAPTITE II, HEX WSHR SLTD U	1.000 EA
35EP3100M04MW	FREP TEFC,"O" DRILLS,NO GRSSR, MACH.WHITE	1.000 EA
HW4032A01	BLACK DRAIN PLUG FOR WASH DOWN MOTORS	3.000 EA
HW5100A03SP	WAVY WASHER (W1543-017)	1.000 EA
35EP3401T07MW	PU EP FOR SEAL W/"O" DRILLS & NO GRS, W/	1.000 EA
HW4600B50SP	SEAL 1.156 X 1.874 X 0.250 SINGLE LIP DB	1.000 EA
HW4032A01	BLACK DRAIN PLUG FOR WASH DOWN MOTORS	3.000 EA
10XN1032S16	10-32X1 HEX HEAD S STEEL	2.000 EA
51XB1214A16	12-14X1.00 HXWSSLD SERTYB	1.000 EA
35FH4005A32SP	IEC FH NO GRSSR W/3 HOLES - PRIMED	1.000 EA
11XW1032S06	10-32 X .38, TAPTITE II, HEX WSHR SLTD U	3.000 EA
HW4600B39SP	V-RING SLINGER 0.550 X 0.790 X .18 VITON	1.000 EA
HW4600B36SP	V-RING SLINGER 1.188 X 1.690 X .24 VITON	1.000 EA
35CB4522	35 LIPPED CB LID PRIMED	1.000 EA
35GS1030A02	35 GS FOR CB LID - WHITE NEOPRENE	1.000 EA
59XW0832S07	TAPTITE II,HEX WSHR UNSLTD SER,410 S.S.,	4.000 EA

Parts List (continued)		
Part Number	Description	Quantity
HW2502D13	SS KEY, 3/16 SQ X 1.375	1.000 EA
HA7000A01	KEY RETAINER 7/8" DIA SHAFT	1.000 EA
MJ5001A27	32220KN GRAY SEALER *MIN BUY 4 QTS=1GAL	0.001 QT
LB1164	LABEL,WARNING AND DRAIN	1.000 EA
85XU0407S04	4X1/4 U DRIVE PIN STAINLESS	2.000 EA
MJ1000A02	GREASE, POLYREX EM EXXON (USe 4824-15A)	0.050 LB
MG1025Z02	ACTIVATOR WILKOFAS 060.02HF	0.010 GA
MG1025W01	WILKOFAS 781.01, SIGNAL WHITE #9003	0.017 GA
HA3100S09	THRUBOLT 9.25 LENGTH SS	4.000 EA
LC0005	CONN.DIA.,TY M,9-LD,DUAL VOLT,REVERSING	1.000 EA
MN416A01	TAG-INSTAL-MAINT no wire (1200/bx) 11/14	1.000 EA
NP1669L	SS WD SUPER-E UL CSA-EEV PREM REV MTG	1.000 EA
36PA1000	PKG GRP, PRINT PK1016A06	1.000 EA

AC Induction Motor Performance Data

Record # 53333 - Typical performance - not guaranteed values

Winding: 35WGM494-R078	Type: 3530M	Enclosure: TEFC
-------------------------------	--------------------	------------------------

Nameplate Data				460 V, 60 Hz: High Voltage Connection	
Rated Output (HP)	2			Full Load Torque	5.99 LB-FT
Volts	230/460			Start Configuration	direct on line
Full Load Amps	5.8/2.9			Breakdown Torque	23.9 LB-FT
R.P.M.	1755			Pull-up Torque	15.9 LB-FT
Hz	60	Phase	3	Locked-rotor Torque	18.1 LB-FT
NEMA Design Code	B	KVA Code	L	Starting Current	24.3 A
Service Factor (S.F.)	1.15			No-load Current	1.82 A
NEMA Nom. Eff.	86.5	Power Factor	73	Line-line Res. @ 25°C	7.46 Ω
Rating - Duty	40C AMB-CONT			Temp. Rise @ Rated Load	61°C
S.F. Amps				Temp. Rise @ S.F. Load	74°C
				Locked-rotor Power Factor	50
				Rotor inertia	0.177 LB-FT ²

Load Characteristics 460 V, 60 Hz, 2 HP

% of Rated Load	25	50	75	100	125	150	S.F.
Power Factor	32	51	64	73	79	82	77
Efficiency	75.7	84.2	86.4	87.3	86.2	85.1	86.4
Speed	1788.5	1778	1766.7	1754.5	1740.8	1726.6	1746
Line amperes	1.92	2.17	2.51	2.94	3.46	4.01	3.25

Performance Graph at 460V, 60Hz, 2.0HP Typical performance - Not guaranteed values

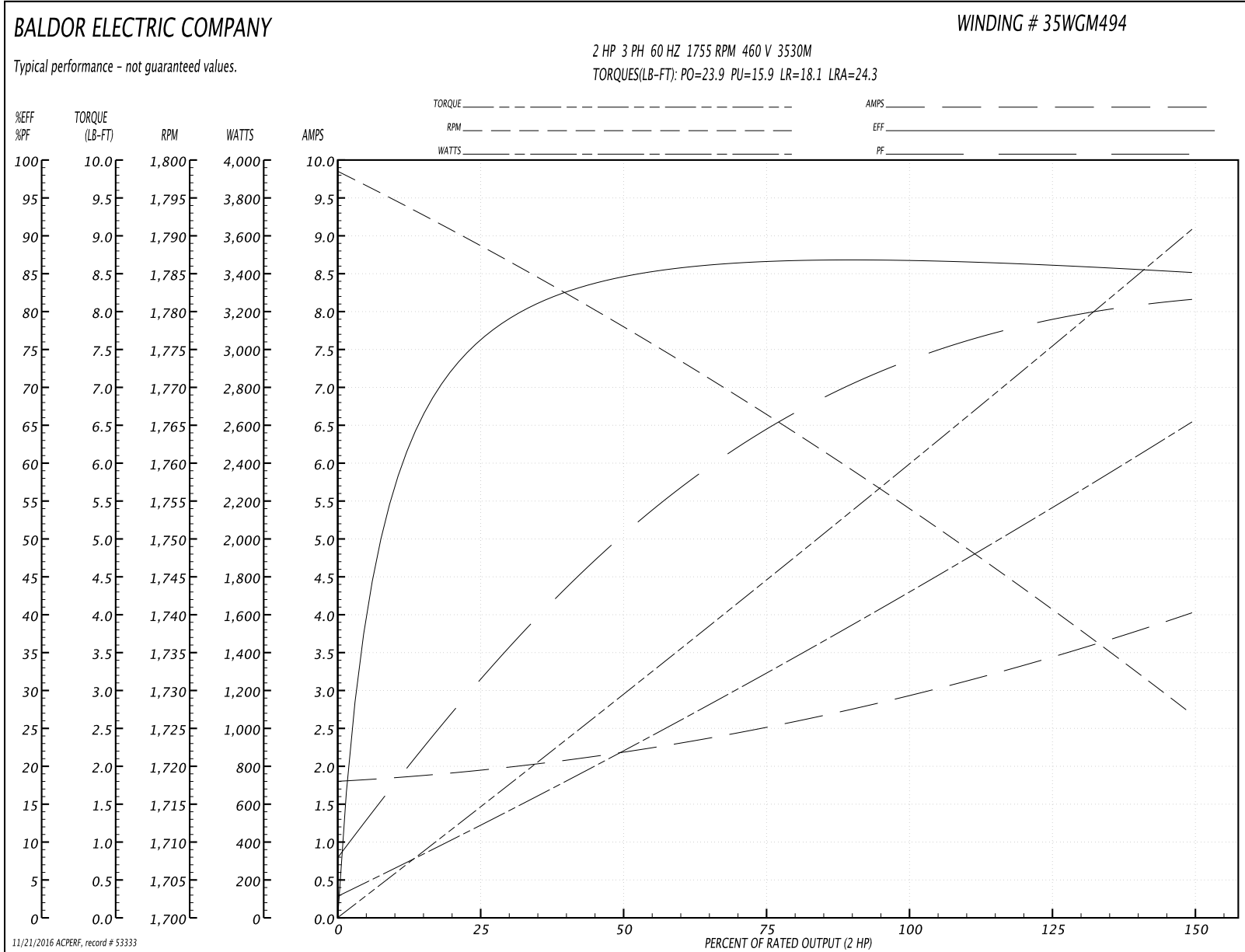

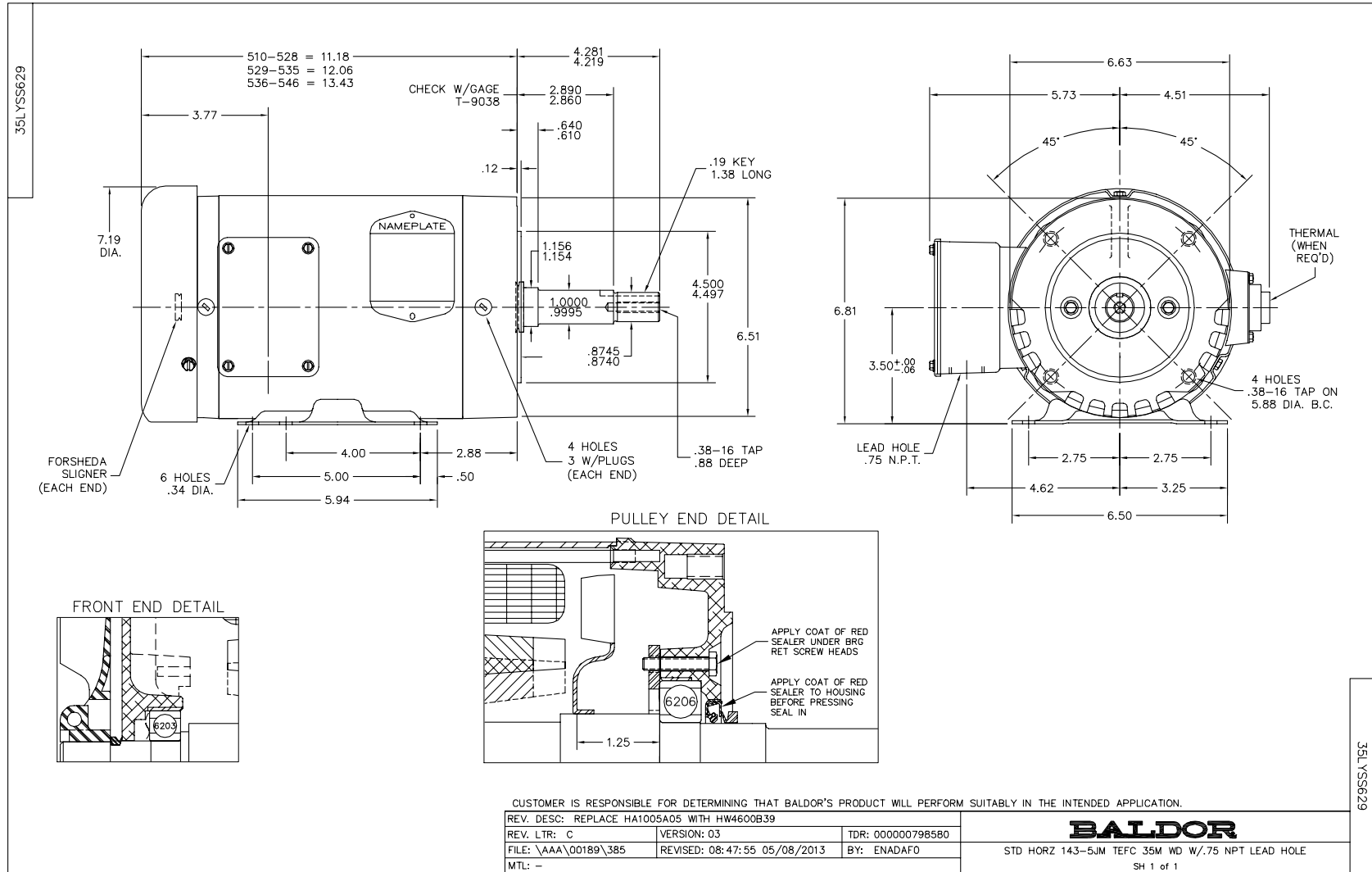

CD0005



LOW VOLTAGE
(2Y)



HIGH VOLTAGE
(1Y)

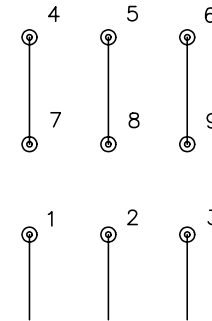

NOTES:

1. INTERCHANGE ANY TWO LINE LEADS TO REVERSE ROTATION.
2. OPTIONAL THERMOSTATS ARE PROVIDED WHEN SPECIFIED.
3. ACTUAL NUMBER OF INTERNAL PARALLEL CIRCUITS MAY BE A MULTIPLE OF THOSE SHOWN ABOVE.
4. LEAD COLORS ARE OPTIONAL. LEADS MUST ALWAYS BE NUMBERED AS SHOWN.

REV. DESC: REVISE TO SHOW OPTIONAL COLORS			
REV. LTR: E	BY: JLP	REVISED: 01/19/99 10:15	TDR: 0171435
90000		FILE: AAA00005140	MDL: -
		MTL: -	

BALDOR ELECTRIC Co.

3PH, DV, 9 LEADS

CD0005