

Submersible Fountain Pumps

DISCHARGE	2" NPT, Female, Vertical
LIQUID TEMPERATURE	77°F (25°C) Continuous
VOLUTE	Cast Iron ASTM A-48, Class 30
MOTOR HOUSING	Cast Iron ASTM A-48, Class 30
SEAL PLATE	Cast Iron ASTM A-48, Class 30
IMPELLER: Design	2 Vane open, with pump out vanes on back side. Dynamically balanced, ISO G6.3
Material:	Cast Iron ASTM A-48, Class 30
SHAFT	416 Stainless Steel
SQUARE RINGS	Buna-N
HARDWARE	300 Series Stainless Steel
PAINT	Air Dry Enamel
SEAL: Design	Single Mechanical, Oil Filled reservoir Secondary Exclusion Seal
Material	Carbon/Ceramic/Buna-N Hardware -300 Series Stainless
CORD ENTRY	15 ft. (5m) Quick Disconnect Cord with plug On 115 Volt, Pressure Grommet for sealing and strain relief
UPPER BEARING	Single Row, Ball, Oil Lubricated
LOWER BEARING	Single Row, Ball, Oil Lubricated
MOTOR: Design	NEMA L Torque curve, Oil Filled, Squirrel cage Induction
Insulation	Class B
SINGLE PHASE	Permanent Split Capacitor (PSC). Includes thermal overload protection in motor
OPTIONAL EQUIPMENT	Seal Material, Additional cord and Cast Iron Impeller

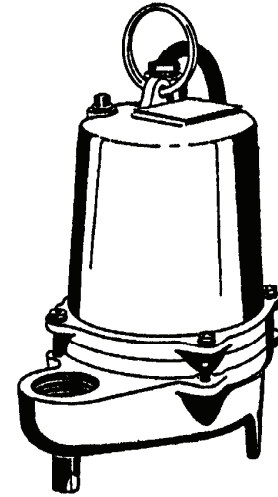

Series: SF
.4HP, 1750RPM, 60Hz



DESCRIPTION:

THESE PUMP ARE SPECIALLY DESIGNED FOR USE IN
DRAMATIC, DECORATIVE WATER DISPLAYS

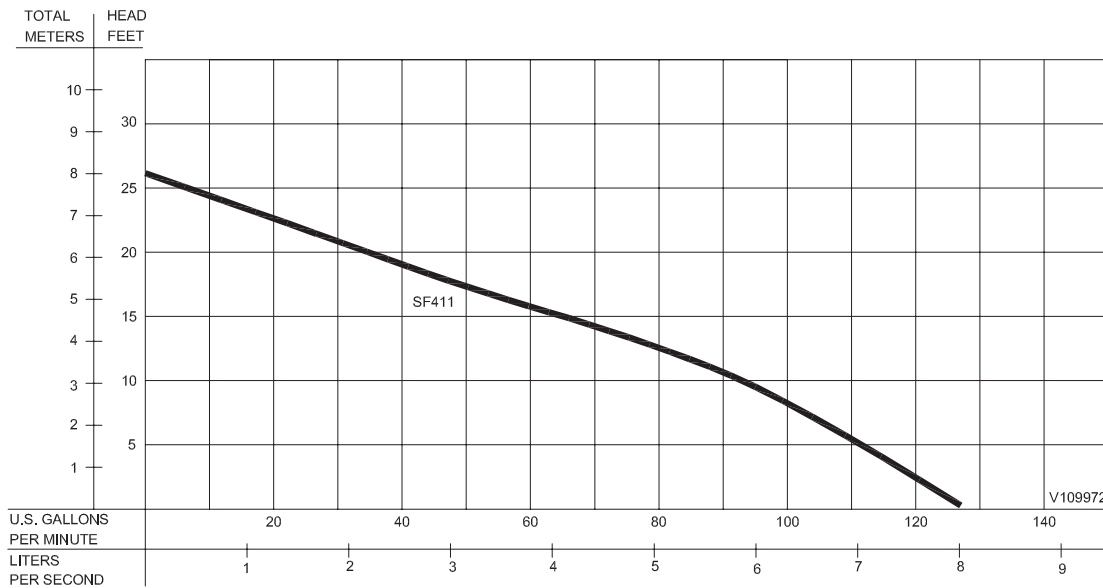

Testing is performed with water specific gravity of 1.0 @ 68°F (20°C), other fluids may vary performance

Submersible Fountain Pumps

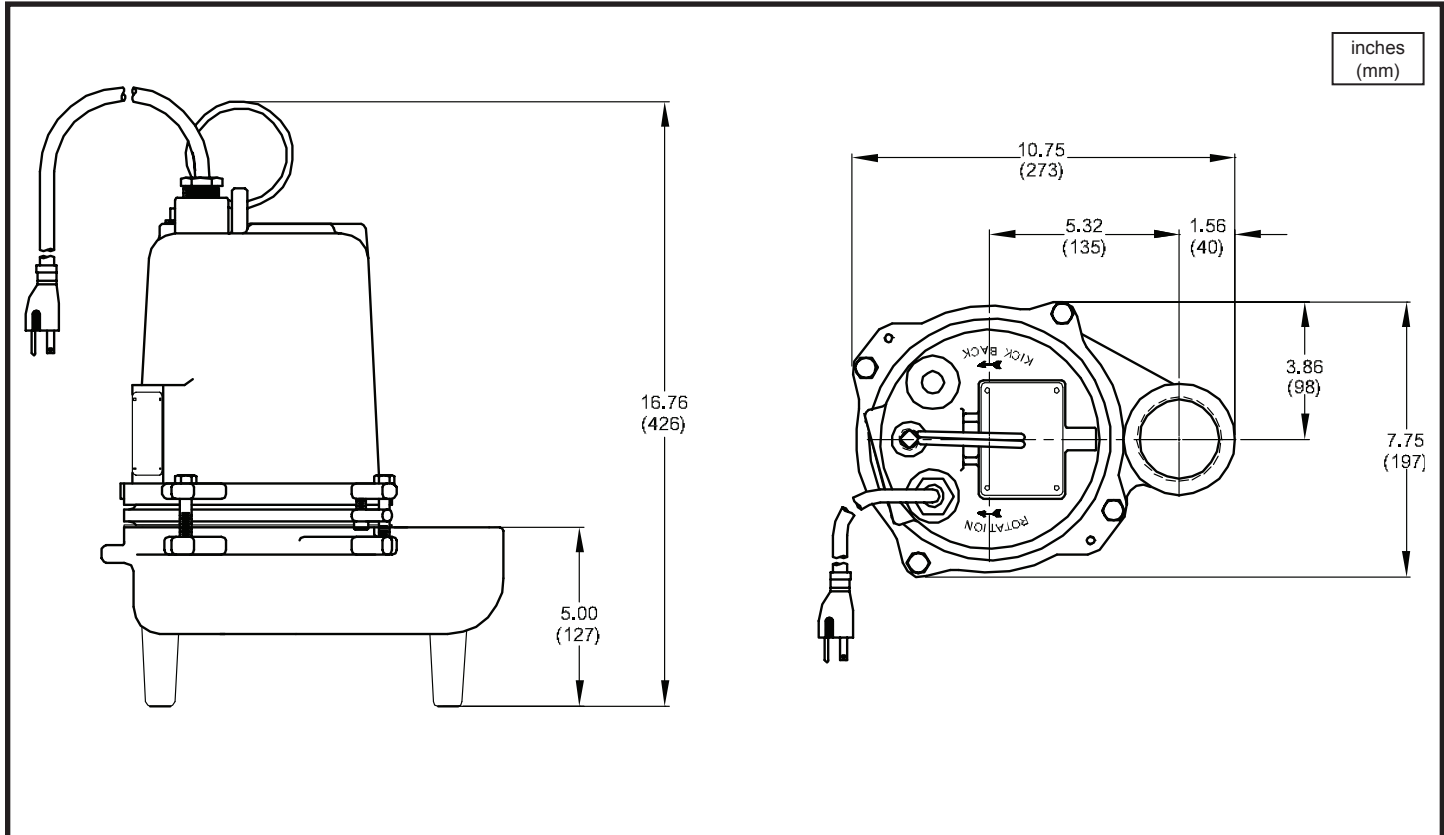

MODEL NO	PART NO	HP	VOLT/PH	Hz	RPM (Nom)	NEMA START CODE	FULL LOAD AMPS	LOCKED ROTOR AMPS	CORD SIZE	CORD TYPE	CORD O.D inch (mm)
SF411	109972	0.4	115/1	60	1750	C	12.0	19.0	14/3	SJTOW	0.375 (9.5)

IMPORTANT !

- 1.) **DO NOT USE TO PUMP FLAMMABLE LIQUIDS.**
- 2.) INSTALLATIONS SUCH AS DECORATIVE FOUNTAINS OR WATER FEATURES PROVIDED FOR VISUAL ENJOYMENT MUST BE INSTALLED IN ACCORDANCE WITH THE NATIONAL ELECTRIC CODE ANSI/NFPA 70 AND/OR THE AUTHORITY HAVING JURISDICTION. THIS PUMP IS NOT INTENDED FOR USE IN SWIMMING POOLS, RECREATIONAL WATER PARKS, OR INSTALLATIONS IN WHICH HUMAN CONTACT WITH PUMPED MEDIA IS A COMMON OCCURRENCE.