

## BERKELEY®

### Type "B" Close-Coupled End-Suction Centrifugal Pumps and Structural Considerations for Vertical Mounting

Providing proper procedures are followed, the Berkeley Type "B" Close-Coupled Electric Motor Drive End-Suction Centrifugal Pump may be mounted in a vertical position. The following are considerations that must be made:

#### Motor

When mounted vertically, the axial load on the motor bearings is generally insignificant for motors under 60 horsepower\*; however, other considerations in regard to the motor must be made. As in horizontal mounting positions, the pump must be first fastened securely at the motor feet using a proper anchor plate, foundation, and anchor bolts as outlined in Berkeley Owner's Manual, (publ. F00634, rev. 10/27/06, pg. 5)\*\*. Precaution must be taken to insure that the motor is protected from precipitation and/or humidity. These measures can be accomplished by using a drip cover or other bonneted-type motor enclosure. It is also necessary that all internal surfaces of the motor freely drain any accumulation of condensation.

#### Pump

When installing a pump in the vertical position, make sure the suction and discharge piping are naturally aligned and adequately supported. A flexible coupling may be used on the discharge side to reduce vibration that may be present. It will also be necessary to properly vent (upon priming) any air that may be trapped in the seal cavity area.

If you would like additional assistance, please consult the factory.

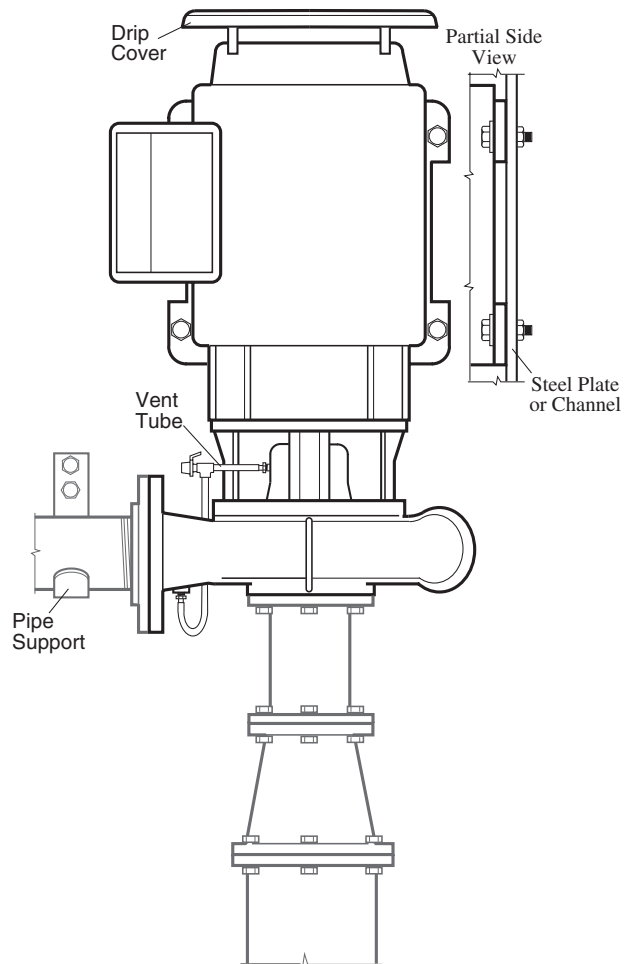

\* Please consult factory for motors larger than 60 horsepower.

\*\* For free standing vertical pump mounting, please consult the factory.

