



WS_BF Series

Model 3887BF 50 Hz

SUBMERSIBLE SEWAGE PUMP

FEATURES

Impeller: Cast iron, semi-open, non-clog, dynamically balanced with pump out vanes for mechanical seal protection. Optional silicon bronze impeller available.

Casing: Cast iron flanged volute type for maximum efficiency. Designed for easy installation on A10-20 slide rail.

Mechanical Seals: SILICON CARBIDE VS. SILICON CARBIDE sealing faces for superior abrasive resistance, stainless steel metal parts, BUNA-N elastomers.

Shaft: Corrosion resistant, 400 series stainless steel. Threaded design. Locknut on three phase models to guard against component damage on accidental reverse rotation.

Fasteners: 300 series stainless steel.

Capable of running dry without damage to components.

Designed for continuous operation, when fully submerged.

APPLICATIONS

Specifically designed for the following uses:

- Homes
- Sewage systems
- Dewatering/Effluent
- Water transfer
- Light industrial
- Commercial applications

Anywhere waste or drainage must be disposed of quickly, quietly and efficiently.

SPECIFICATIONS

Pump:

- Solids handling capabilities: 2" maximum
- Capacities: up to 160 GPM
- Total heads: up to 26 feet TDH
- Discharge size: 2" NPT threaded companion flange standard. 3" option available but must be ordered separately. (Order no. A1-3)
- 2" or 3" BSPP Connection (optional)
- Temperature:
 - 104°F (40°C) continuous
 - 140°F (60°C) intermittent.
- See order numbers on reverse side for specific HP, voltage, phase and RPMs available.

MOTORS

- Fully submerged in high grade turbine oil for lubrication and efficient heat transfer. All ratings are within the working limits of the motor.

Class B insulation

- All single phase models feature capacitor start motors for maximum starting torque.

Single phase (50 Hz):

- Built-in overload with automatic reset.
- 1/3 and 1/2 HP – 16/3 SJTOW with bare leads.
- 3/4 – 14/3 STOW with bare leads.

Three phase (50 Hz):

- Overload protection must be provided in starter unit.
- 1/3 - 3/4 HP – 14/4 STOW with bare leads.
- **Designed for Continuous Operation:** Pump ratings are within the motor manufacturer's recommended working limits, can be operated continuously without damage.
- **Bearings:** Upper and lower heavy duty ball bearing construction.
- **Power Cables:** Severe duty rated, oil and water resistant. Epoxy seal on motor end provides secondary moisture barrier in case of outer jacket damage and to prevent oil wicking. 20 foot standard with optional lengths available.
- **Motor Cover O-ring:** Assures positive sealing against contaminant and oil leakage.

MODELS

Order Number	HP	Volts	Phase	RPM	Impeller Diameter	Maximum Amps	Weight (lbs.)
WS0329BF	1/3	220	1	1450	5"	7.2	68
WS0346BF		380	3			1.3	
WS0529BF	1/2	220	1		5 3/8"	7.8	70
WS0546BF		380	3			1.5	
WS0729BF	3/4	220	1		5 3/4"	8.6	75
WS0746BF		380	3			2.3	

Complete System Components available in the accessory section of this catalog.

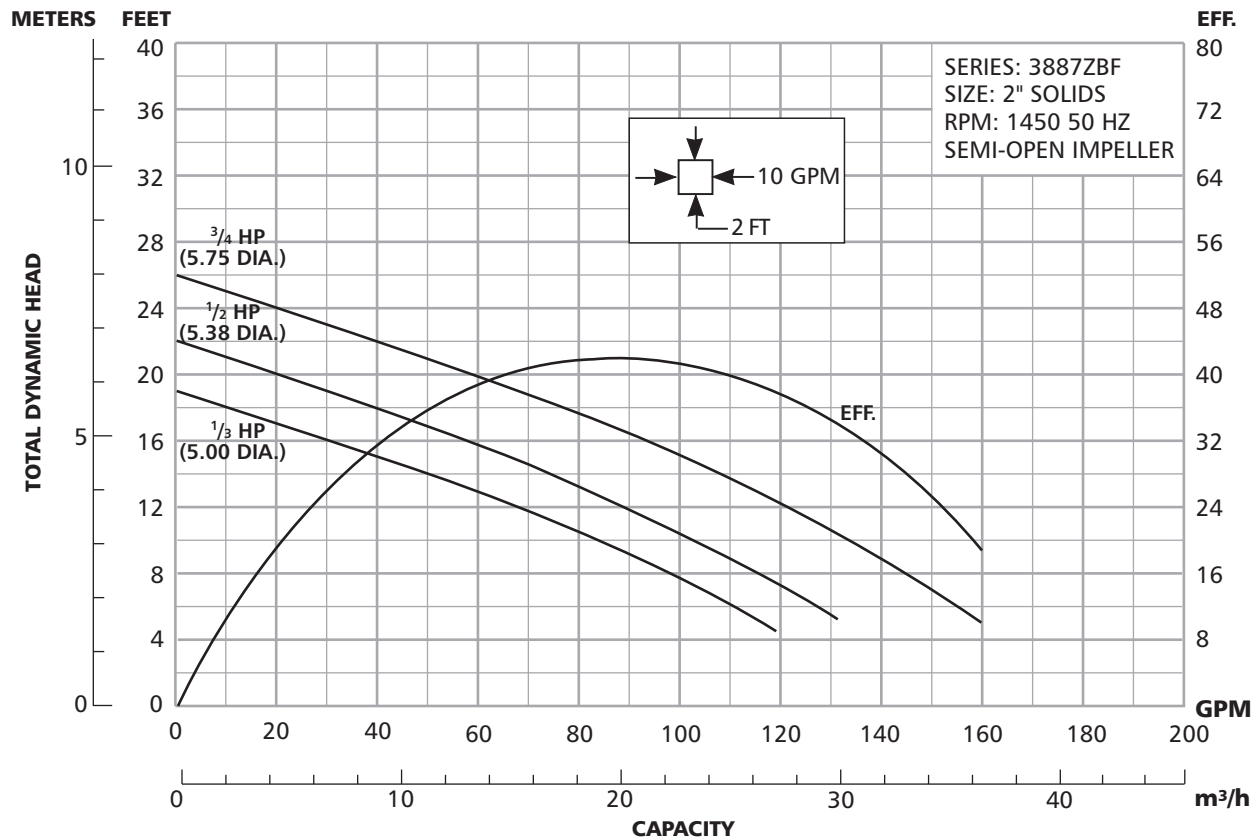

DIMENSIONS

(All dimensions are in inches. Do not use for construction purposes.)

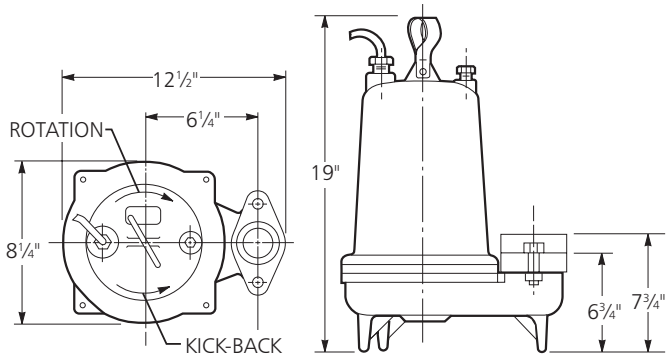

COMPONENTS FOR REFERENCE ONLY

Item No.	Description
1	Impeller
2	Casing
3	Silicon carbide vs. silicon carbide Mechanical seal
4	Shaft
5	Motor
6	Ball bearings
7	Power cable
8	O-ring

NOTE: Repair parts may be ordered from repair parts list.

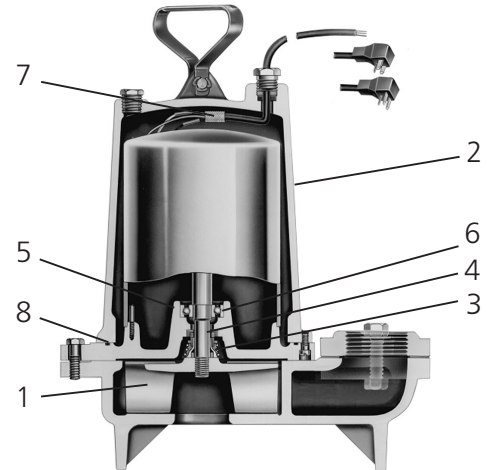

xylem
Let's Solve Water

Xylem, Inc.
2881 East Bayard Street Ext., Suite A
Seneca Falls, NY 13148
Phone: (866) 325-4210
Fax: (888) 322-5877
www.xylem.com/brands/gouldswatertechnology

Goulds is a registered trademark of Goulds Pumps, Inc. and is used under license.
© 2011 Xylem Inc. B3887ZBF December 2011