

# OPERATOR'S MANUAL EB20-XXXX-XXX-XXX

INCLUDING: OPERATION, INSTALLATION AND MAINTENANCE

RELEASED: 2-1-24  
(REV: A)

## 2" EVO SERIES™ DIAPHRAGM PUMP (METALLIC FLUID SECTIONS)

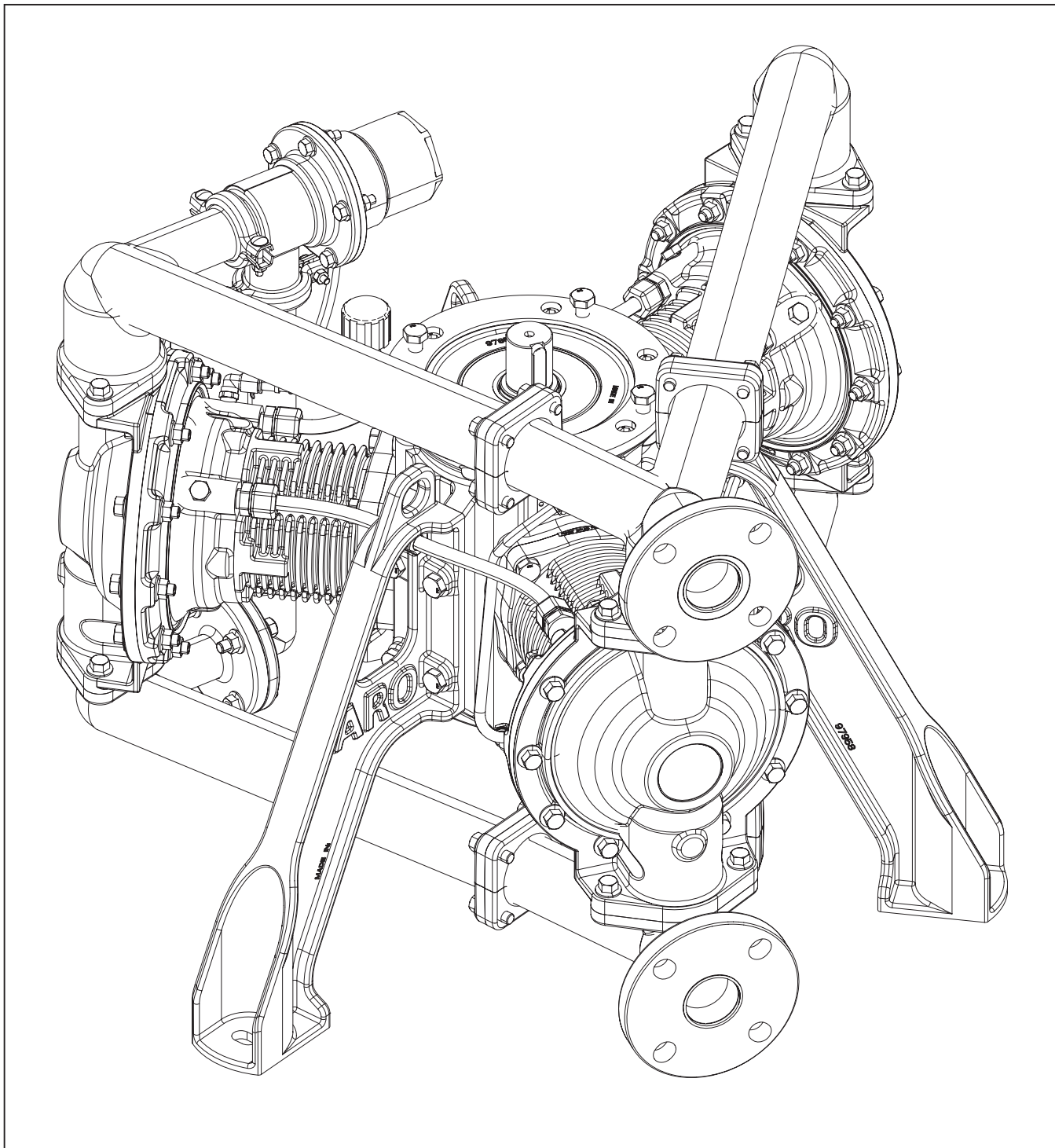

---

**TABLE OF CONTENTS**

---

1. TECHNICAL SPECIFICATIONS .....	3	8. MAINTENANCE .....	11
1.1. Pump Data .....	3	8.1. Service Kits.....	11
1.2. Nameplate Details.....	4	9. SUBSYSTEM OVERVIEW .....	12
1.2.1 Standard Nameplate .....	4	9.1. Fluid section .....	12
1.2.2 Hazardous Nameplate .....	4	9.2. PRV section .....	15
2. MODEL DESCRIPTION CHART.....	5	9.3. No PRV section.....	18
2.1. Model Code Explanation.....	5	9.4. Crankcase section .....	19
2.2. Model Code Details.....	6	9.5. Oil Piston pump section .....	22
3. OPERATING AND SAFETY PRECAUTIONS.....	7	10. TROUBLESHOOTING .....	24
4. GENERAL DESCRIPTION .....	8	11. DIMENSIONAL DATA.....	25
4.1. Introduction .....	8	11.1 Pump (with or without PRV) .....	25
4.2. Storage .....	8	11.2. Pump interface details .....	26
4.3. Unpacking .....	8	12. PERFORMANCE CURVE.....	27
5. MECHANICAL INSTALLATION.....	9	13. CERTIFICATION .....	29
5.1. Pump Installation .....	9	13.1 Certification Standards and Markings ....	29
5.2. Pump Breather Installation .....	9	13.2 Specific Conditions of Use .....	29
6. GROUNDING .....	10	14. WARRANTY DECLARATION.....	30
7. OPERATION.....	10		

# 1. TECHNICAL SPECIFICATIONS

## 1.1. Pump Data

**Models** . . . . . See Model Description Chart for “-XXXXX”.

**Pump Type** . . . Mechanically Driven Diaphragm Pump

**Material** . . . . . See Model Description Chart

**Weight**

EB20-CXXXX-XXX-XXA . . . . . 477 lbs (216 kg)

EB20-AXXXX-XXX-XXA . . . . . 376 lbs (171 kg)

EB20-SXXXX-XXX-XXA . . . . . 517 lbs (235 kg)

**Maximum Material**

**Inlet Pressure** <sup>②</sup> . . . . . 60 psig (4.14 bar)

**Maximum Outlet Pressure** . . . . . 120 psig (8.3 bar)

**Maximum Flow Rate** (flooded inlet) . . . 140 gpm (530 lpm)

**Displacement / Cycle @ 80 psig** . . . 0.66 gal. (2.5 lit.)

**Maximum Particle Size** . . . . . 1/4" dia. (6.4 mm)

**Wet Suction Lift** . . . . . 30 ft (9.1 m)

**Dry Suction Lift** . . . . . 18 ft (5.4 m)

**Maximum Temperature Limits**

	Min	Max	Min	Max
Ambient Temperature <sup>①</sup>	0° F	104° F	-18° C	40° C
Fluid Temperature	32° F	212° F	0° C	100° C
Fluid temperature should be further limited of one of the following materials of construction is used in the wetted sections:				
PTFE	40° F	212° F	4° C	100° C

**⚠ WARNING** *Maximum fluid temperature of 100° C should never be exceeded to maintain hazardous area surface temperature nameplate rating.*

**Dimensional Data** . . . . . See page 25 and 26

**Mounting Dimension** . . 3 Equally placed  
 Ø 0.63" (Ø 16 mm) x  
 0.94" (24 mm) hole on  
 Ø 29.8" (Ø 758 mm) B.C.

Noise Emission Values in accordance with ISO 4871 <sup>③</sup>		
Pump configuration	EP20-AFAAA-CSV-ACA (Santoprene® Balls / Seats)	EP20-SFSST-CSV-ACA (SST Balls / Seats)
Pump Only PN	EB20-AFAAA-CSV-00A	EB20-SFSST-CSV-00A
<b>Sound Power</b>		
99 rpm @ 100 psig	78.9 dB(A)	96.3 dB(A)
198 rpm @ 60 psig	88.5 dB(A)	101.2 dB(A)
<b>Sound Pressure</b>		
99 rpm @ 100 psig	68.8 dB(A)	86.1 dB(A)
198 rpm @ 60 psig	78.4 dB(A)	91.0 dB(A)





① Do not allow fluids to freeze inside of pump.  
 ② When using inlet pressures higher than 10 psig (0.69 bar), the outlet pressure should be monitored to ensure it does not exceed the max allowable pressure at each respective speed as defined by the performance curves in section 12. For example, the maximum outlet pressure at 99 rpm is 100 psig (6.89 bar). As the inlet pressure is increased, this maximum outlet pressure should not be exceeded as it will require a lower shaft torque to achieve this pressure.  
 ③ Values are determined according to noise test code ISO 20361 using ISO noise measurement standards. Measurement locations of 1m taken at pump/driver midline as per B.3.1 and 6.2 as defined in standard. Calculated A-weighted sound pressure level using half-spherical surface. Published using uncertainty value of 3.

## 1.2. Nameplate Details



Items supplied vary according to product configuration.

Make sure that the items supplied and the information on the nameplate correspond to the order confirmation.

### 1.2.1 Standard Nameplate

<b>ARO EVO SERIES</b>				<b>98179</b>
PUMP MODEL <sup>①</sup>	<input style="width: 150px;" type="text"/>	ASSEMBLED IN <sup>②</sup>	<input style="width: 50px;" type="text" value="USA"/>	
SERIAL NO. <sup>③</sup>	<input style="width: 150px;" type="text"/>	MFGR DATE <sup>④</sup>	<input style="width: 100px;" type="text"/>	
<input type="radio"/> AVG W.P. <sup>⑤</sup>	<input style="width: 50px;" type="text" value="psig"/> <input style="width: 50px;" type="text" value="bar"/>	MAX W.P. <sup>⑥</sup>	<input style="width: 50px;" type="text" value="psig"/> <input style="width: 50px;" type="text" value="bar"/>	
AMBIENT TEMP <sup>⑦</sup>	<input style="width: 150px;" type="text" value="-18°C TO 40°C"/>			
 US: Bryan, OH 43506 <sup>⑧</sup> EU: Lakeview Dr. IE Swords				  US

### 1.2.2 Hazardous Nameplate

PUMP MODEL <sup>①</sup>	<input style="width: 150px;" type="text"/>	SERIAL NO. <sup>③</sup>	<input style="width: 100px;" type="text"/>
		Tamb <sup>⑦</sup>	<input style="width: 100px;" type="text" value="-18°C TO +40°C"/>
  II 2G Ex h IIB T4 Gb II 2D Ex h IIIC T135°C Db			
1725 US HIGHWAY 1 NORTH, SOUTHERN PINES, NC 28387, USA <sup>⑧</sup> 			

#### Definitions

1. Pump Model - Configured Pump Model Number
2. Assembled In - Country of Assembly
3. Serial Number - Serial Identification Number (Includes Date of Manufacture - Month, Day, Year)
4. MGFR Date - Date of Manufacture
5. AVG W.P - Average Pump Working Pressure
6. Max W.P - Maximum Pump Working Pressure
7. Ambient Temp - Allowable Ambient Temperature Range
8. Customer service contact locations
  - USA: 209 N. Main Street, Bryan, OH 43506
  - EU: 165 Lakeview Drive, Swords, Ireland
9. Manufacturing location, USA: 1725 US Highway 1 North, Southern Pines, NC 28387

#### Serial Number Identification

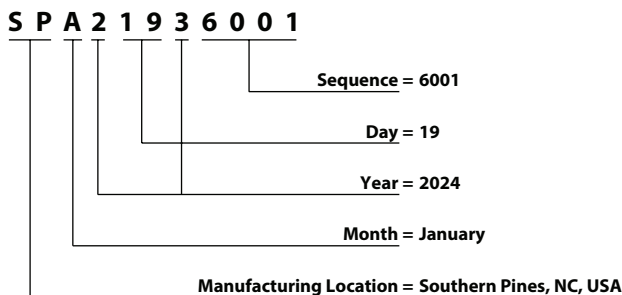

Code	Month
A	JAN
B	FEB
C	MAR
D	APR
E	MAY
F	JUN
G	JUL
H	AUG
I	SEP
J	OCT
K	NOV
L	DEC

• Viton® is a registered trademarks of the Chemours Company • Loctite® is a registered trademark of Henkel Corporation • Santoprene® is a registered trademark of Celanese • ARO® is a registered trademark of Ingersoll-Rand Company •

## 2. MODEL DESCRIPTION CHART

### 2.1. Model Code Explanation

	E	B	2	0	-	X		X		X		X	-	X		X	-	X		X		X	
<b>Wetted Parts</b>																							
A - Aluminum																							
C - Cast Iron																							
S - Stainless Steel																							
<b>Port</b>																							
F - ANSI / DIN Hybrid Flange with integrated PRV																							
G - ANSI / DIN Hybrid Flange without integrated PRV																							
<b>Seat</b>																							
A - Santoprene®																							
F - Aluminum																							
H - 440 SST																							
S - 316 SST																							
<b>Ball</b>																							
A - Santoprene®																							
S - 316 SST																							
T - PTFE																							
<b>Diaphragms</b>																							
A - Santoprene®																							
T - PTFE																							
<b>Pump Crank case</b>																							
C - Cast Iron																							
<b>Pump Input Shaft</b>																							
K - Keyed Shaft (40mm)																							
S - Integrated Spline Shaft																							
<b>Bellows</b>																							
V - Viton®																							
<b>Mount Option</b>																							
0 - None																							
<b>Option</b>																							
0 - None																							
<b>Revision</b>																							
A - Revision																							
<b>Special Testing</b>																							
<i>Pumps requiring special tests will have a separate line item on the Purchase Order</i>																							
<b>NOTICE: All possible options are shown in the chart, however, certain combinations may not be recommended. Consult a representative or the factory if you have questions concerning availability.</b>																							

## 2.2. Model Code Details

The EVO EB20-XXXXX-XXX-XXX model series is a pump only configuration that requires a customer-supplied power source, such as an electric motor, hydraulic motor, or gas powered engine. In most cases, a speed reducer will also be required which is not included. There are several details to consider when selecting an EB model:

### Customer-Pump Interface

The EB model can be selected with either an integrated spline crankshaft "S" or a keyed crankshaft "K". The keyed shaft interface is recommended since this is the most common interface. The spline shaft is offered for specific situations where a custom spline can be produced on the output shaft of a gearbox to eliminate the need for a bell housing and shaft coupling or when used with an ARO supplied motor (see EP20-XXXXX-XXX-XXX). For keyed shaft models, a pump-to-gearbox adapter (bell housing) and a shaft coupling will be required (not included). The shaft coupling should be selected to meet the torque requirements for the intended operating condition as shown by the performance curves in section 12.

Flange Shaft Detail: 250 mm B5 Flange per IEC 60072-1:2022 (see section 11.2)

Keyed Shaft Detail: Ø40 k6 x 50.5 mm, Shaft Key Included (see section 11.2)

Spline Shaft Detail: N35 x 2 x 16 x 9H per DIN 5480-1 (see section 11.2)

### Integrated Pressure Relief Valve (PRV)

The EB model can also be selected with or without an integrated pressure relief valve (PRV). The purpose of the PRV is to provide protection specifically to the pump in the event of a rapid pressure spike due to downstream fluid dynamics, sudden valve closure, or blockage. The integrated PRV does not replace the need for any system level protection downstream of the pump. It is only intended to handle transient events and should not be used for continuous by-pass. The PRV is not adjustable, and it is set to open above the max allowable pressure of the pump and should not open under normal operating conditions. The EB models are not intended for use in applications where deadhead is required or expected. For full deadhead capability, see the EP20-XXXXX-XXX-XXX model series. The "G" model can be selected to remove the integrated pressure relief valve when the application does not require the additional level of pump protection or when sufficient system level protection is in place.

### Diaphragm Leak Detection

The EB model series does not include integrated leak detection sensors. It is highly recommended that a method of leak detection is implemented to ensure that the pump does not continue to run in the event of a diaphragm failure. The pump is equipped with a rubber bellows for secondary containment to ensure separation of the process fluid and the crankcase oil, however, the bellows is not intended to operate for an extended period of time when exposed to the process fluid and pressure. To implement optical leak detection sensors for ordinary applications see EP20-XXXXX-XXX-XXX manual (PN 97999-1958) section 6.5.1. For hazardous applications, see section 7.3.1. It is also possible to implement visual leak detection using the 1/4" port on the bottom side of each air cap.

**NOTE:** The 1/4" NPT leak detect ports in the bottom of each air cap are open to atmosphere as shipped from the factory. It is the customer's responsibility to ensure proper leak detection and product containment are in place before the pump is put in operation.

### Performance

In order to select an appropriate motor and gearbox, please refer to the performance curves in section 12. The maximum published speed, torque, flow, and pressure should not be exceeded at any given operating point. The performance curves show the speed, torque, and power required at the pump input shaft to achieve the published pressure and flow points using water. The power motor sizing will need to take into account any gearbox losses.

### 3. OPERATING AND SAFETY PRECAUTIONS

READ, UNDERSTAND, AND FOLLOW THIS INFORMATION TO AVOID INJURY AND PROPERTY DAMAGE.



**⚠ WARNING** **STATIC SPARK.** Can cause explosion resulting in severe injury or death. Ground pump and pumping system.

- Sparks can ignite flammable material and vapors.
- The pumping system and object being sprayed must be grounded when it is pumping, flushing, recirculating or spraying flammable materials such as paints, solvents, lacquers, etc. or used in a location where surrounding atmosphere is conducive to spontaneous combustion. Ground the dispensing valve or device, containers, hoses and any object to which material is being pumped.
- Secure pump, connections and all contact points to avoid vibration and generation of contact or static spark.
- Consult local building codes and electrical codes for specific grounding requirements.
- After grounding, periodically verify continuity of electrical path to ground. Test with an ohmmeter from each component (e.g., hoses, pump, clamps, container, spray gun, etc.) to ground to ensure continuity. Ohmmeter should show 0.1 ohms or less.
- Submerge the outlet hose end, dispensing valve or device in the material being dispensed if possible. (Avoid free streaming of material being dispensed.)
- Use hoses incorporating a static wire.
- Use proper ventilation.
- Keep inflammables away from heat, open flames and sparks.
- Keep containers closed when not in use.

**⚠ WARNING** Excessive fluid pressure developed by pump can cause personal injury, pump damage or property damage.

- Fluid pressure developed by the pump should not exceed the maximum as stated on the pump model plate.
- Be sure material hoses and other components are able to withstand fluid pressures developed by this pump. Check all hoses for damage or wear. Be certain dispensing device is clean and in proper working condition.

**⚠ WARNING** **INSTALLATION OF COMPONENTS FOR HAZARDOUS DUTY APPLICATIONS.**

- Pumps that will operate in environments defined as "hazardous locations" must only be installed, connected and set-up by qualified personnel with knowledge and understanding of protection classes, regulations and provisions for apparatus in hazardous areas, for the region where the pump will operate, because these regulations and provisions, along with the definition of what constitutes hazardous areas vary by location.

**⚠ WARNING** **HAZARDOUS PRESSURE.** Can result in serious injury or property damage. Do not service or clean pump, hoses or dispensing valve while the system is pressurized.

- Disconnect and lockout / tagout power supply to the pump. Relieve pressure from the system by opening dispensing valve or device and / or carefully and slowly loosening and removing outlet hose or piping from pump.

**⚠ WARNING** **HAZARDOUS MATERIALS.** Can cause serious injury or property damage. Do not attempt to return a pump to the factory or service center that contains hazardous material. Safe handling practices must comply with local and national laws and safety code requirements.

- Obtain Material Safety Data Sheets on all materials from the supplier for proper handling instructions.

**⚠ WARNING** **EXPLOSION HAZARD.** Models containing aluminum wetted parts cannot be used with 1-1-1-Trichloroethane, Methylene Chloride or other Halogenated Hydrocarbon solvents which may react and explode.

- Check pump crankcase section, PRV section, Oil module section, fluid caps, manifolds and all wetted parts to assure compatibility before using with solvents of this type.

**⚠ WARNING** **MISAPPLICATION HAZARD.** Do not use models containing aluminum wetted parts with food products for human consumption. Plated parts can contain trace amounts of lead.

**⚠ CAUTION** Verify the chemical compatibility of the pump wetted parts and the substance being pumped, flushed or recirculated. Chemical compatibility may change with temperature and concentration of the chemical(s) within the substances being pumped, flushed or circulated. For specific fluid compatibility, consult the chemical manufacturer.

**⚠ CAUTION** **HOT SURFACE.** Metallic wetted sections can reach up to the same temperature as the fluid temperature (up to 100°C). Precautions should be taken to restrict access to hot surfaces when needed. Proper personal protective equipment (PPE) for hot surfaces should be worn. Check to ensure parts have cooled down sufficiently prior to any maintenance.

**⚠ CAUTION** Maximum temperatures are based on mechanical stress only. Certain chemicals will significantly reduce maximum safe operating temperature. Consult the chemical manufacturer for chemical compatibility and temperature limits. Refer to PUMP DATA on page 3 of this manual.

**⚠ CAUTION** Be certain all operators of this equipment have been trained for safe working practices, understand it's limitations, and wear safety goggles / equipment when required.

**⚠ CAUTION** Do not use the pump for the structural support of the piping system. Be certain the system components are properly supported to prevent stress on the pump parts.

- Suction and discharge connections should be flexible connections (such as hose), not rigid piped, and should be compatible with the substance being pumped.

**⚠ CAUTION** Prevent unnecessary damage to the pump. Do not allow pump to operate when out of material for long periods of time.

**⚠ CAUTION** Use only genuine ARO replacement parts to assure compatible pressure rating and longest service life.

**NOTICE** TORQUE ALL FASTENERS BEFORE OPERATION. Creep of housing and gasket materials may cause fasteners to loosen. Torque all fasteners to ensure against fluid or air leakage.

**⚠ WARNING** = Hazards or unsafe practices which could result in severe personal injury, death or substantial property damage.

**⚠ CAUTION** = Hazards or unsafe practices which could result in minor personal injury, product or property damage.

**NOTICE** = Important installation, operation or maintenance information.

## 4. GENERAL DESCRIPTION

### 4.1. Introduction

The EVO Series diaphragm pump offers a unique combination of benefits in the positive displacement pump market. It features a broad range of material compatibility options, high volume delivery, secondary containment and efficiency. The pump works on the principle of converting rotary motion to linear reciprocating motion to drive a diaphragm. A customer-supplied power source is coupled to a rotating eccentric crankshaft to drive connecting rods and pistons which in turn drive three independent diaphragms. Three diaphragms are used to ensure reduced pulsation and noise for smoother and more reliable flow.

### 4.2. Storage

Place the equipment in a clean dry area, protected from impacts, vibrations, temperature extremes and in an environment with relative humidity less than 90%. When storing for longer than six months, consult the manufacturer.

### 4.3. Unpacking

Items supplied vary according to product configuration. Make sure that the items supplied and the information on the nameplate correspond to the order confirmation. Check the individual packaging and the product visually for damage caused by inappropriate handling during shipment. **NOTE:** In-case of damage, report the damage to the transport company and thereafter contact IR distributor.

**NOTICE**

*To protect consumer rights please keep the Label intact on the Pump.*

## 5. MECHANICAL INSTALLATION

### 5.1. Pump Installation

**⚠ WARNING** Pumps are industrial products. They must therefore be installed by qualified, experienced and authorized personnel. The safety of people, animals and property must be ensured when installing the pump.

Once Pump has been fully unpackaged and inspected, use lifting points on Crankcase to move into final operating position (See Figure.1).

- Ensure straps and lifting device are properly rated. Refer section 1.1 for pump weight.
- All three lifting points should be used for stability.
- Lifting points on Crankcase are intended to only move the pump.
- Do not use pump Manifolds to lift the equipment.
- Ensure installation location has enough overhead room to install a power source vertically from above.
- Ensure adequate clearance around pump for sufficient access and ventilation.
- Ensure the pump is installed on flat level surface.

Secure pump legs to floor with M14 anchors.

- Refer to section 11.1 for bolt circle spacing.
- Pump must be positioned such that fluid inlet and fluid outlet port are easily accessible.

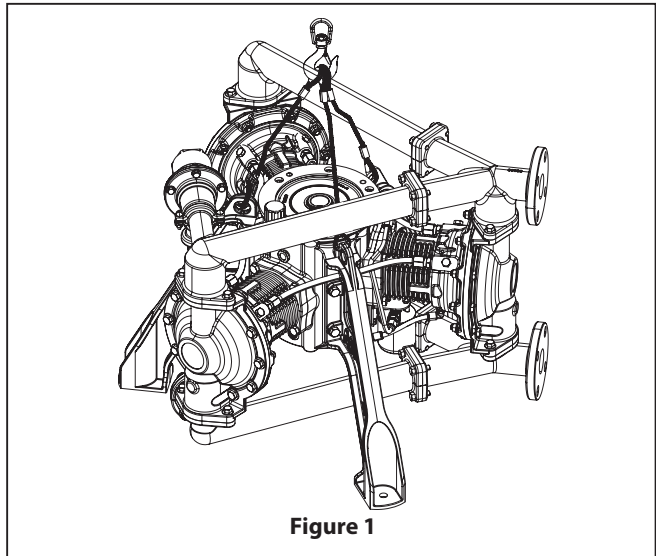

Figure 1

### 5.2. Pump Breather Installation

Once the pump is in place, the oil breather will need to be installed in the upper cap of the pump Crankcase.

- The pump Crankcase will come pre-filled with oil.
- Remove temporary shipping plug (orange) from the breather port in upper cap of the Crankcase housing.
- Remove the plastic elbow (127) and breather (126) secured to one of the pump legs.
- Install the plastic elbow until NPT connection is 1-2 turns from hand-tight with the outlet of the elbow pointing upwards.
- Install breather onto elbow such that it is in the vertical orientation.

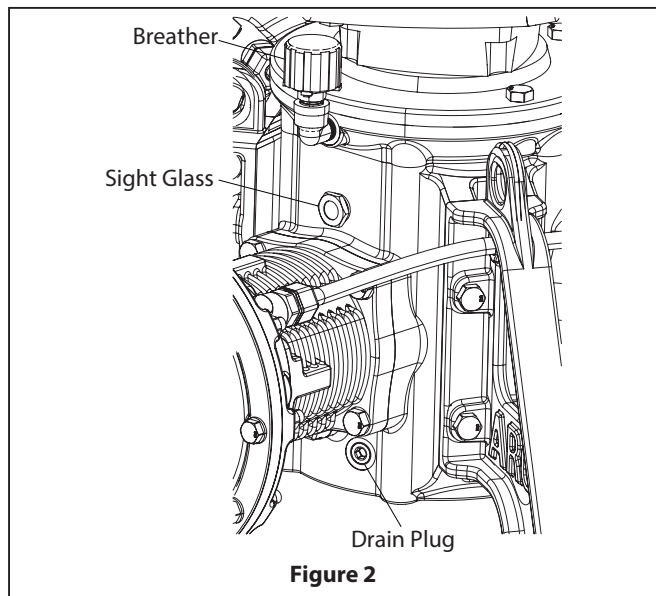

Figure 2

---

## 6. GROUNDING

---

Before operating the pump, ground the system as explained below.

### **Pump Grounding**

- All pumps have a ground screw installed in Crankcase housing. Connect one end of the grounding wire to ground screw and other end of the grounding wire to suitable earth ground.
- The cross section of the grounding wire must be at least 4 mm<sup>2</sup>.

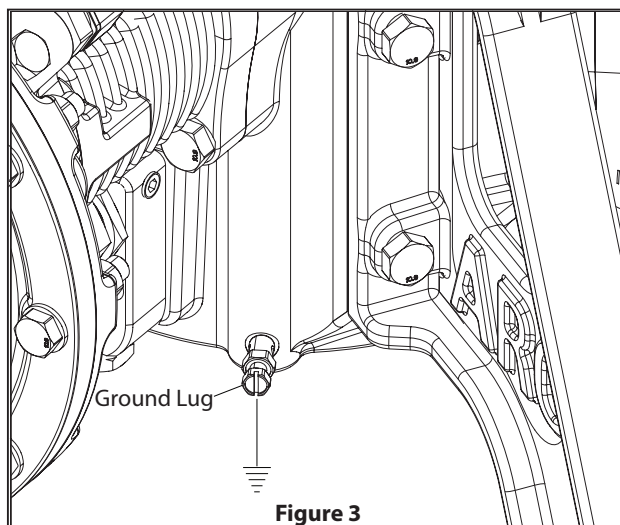

---

## 7. OPERATION

---

### **Pre Operation Checklist**

- Always flush the pump with a solvent compatible with the material being pumped if the material being pumped is subject to "setting up" when not in use for a period of time.
- The outlet material volume is governed not only by the Fluid pressure but also by the material supply available at the inlet. The material supply tubing should not be too small or restrictive. Be sure not to use hose which might collapse.
- Secure the pump legs and bolted to a suitable surface (concrete floor) to ensure against damage by vibration.

## 8. MAINTENANCE

Refer to the part views and descriptions as provided on page 12 through 23 for parts identification and Service Kit information.

- Service kits are divided to service four separate section: 1. CRANKCASE SECTION, 2. FLUID SECTION, 3. PRV SECTION, 4. OIL FILTRATION SECTION. The FLUID SECTION and PRV SECTION is divided further to match typical part MATERIAL OPTIONS.
- Provide a clean work surface to protect sensitive internal moving parts from contamination from dirt and foreign matter during service disassembly and reassembly.
- Keep good records of service activity and include pump in preventive maintenance program.
- Before disassembling
  - Empty oil from Crankcase housing through drain port. Remove 3/8" NPT drain plug in Crankcase housing below lowest cylinder.
  - Empty captured material in the outlet Manifold by running the pump long enough to thoroughly clean the pump and hoses.
  - Remove bolt from PRV Manifold and empty captured material from inlet Manifold.

### MAINTENANCE RECOMMENDATIONS – FLUID SECTION

Maintenance Item	Frequency	Indication
Diaphragms	As needed	It is recommended to install optical leak detection in the bottom 1/4" NPT port in each air cap to detect a diaphragm leak or failure. If optical leak detection is not permissible, then visual or some other detection method should be employed to prevent the pump from continuing to run with a failed diaphragm.
Rubber Bellows	Every Diaphragm change	Preventative to ensure robust protection of pump Crankcase.
Balls	As needed	Erratic pump behavior, excessive pulsation, reduction in flow; Visual inspection.
Seats	As needed	Visual inspection
PRV Bellows	As needed (EB20-XFXXX-XXX-XXX models with the integrated PRV only)	In the event of a PRV bellows rupture, fluid will be fully contained and directed to the air cap directly below the PRV.

**NOTE:** Frequency of maintenance fluid section maintenance items is dependent on fluid abrasiveness, cycle rate, pressure conditions, temperature, compatibility of the fluid, and duty cycle.

### MAINTENANCE RECOMMENDATIONS – PUMP CRANKCASE

Maintenance Item	Frequency	Indication
Oil Change/ Filter Element	Every 5,000 hrs or once per year	Scheduled

- During pump maintenance, it is recommended to rotate the Crankshaft manually to ensure that it is rotating freely.
- Monitor oil level in Crankcase assembly through sight glass fitted in pump. For hazardous applications, check oil level weekly.

**WARNING:** It is recommended to check the oil level in the pump crankcase once a week for hazardous applications.

Use only ARO genuine oil for crankcase oil changes to ensure proper functionality and compatibility (see service kit PN below). 7.5 liters of oil are included in the service kit. 6.0 liters are required for the crankcase. The remaining oil can be used to maintain proper oil levels in the event of any oil loss.

### 8.1. Service Kits

Refer to Model Description Chart to match the pump material options.

**637555-XX** for Fluid section repair (see page 12).

**67557-X** for PRV section assembly (see page 15).

**EP20-CXVX-01-A** for Crankcase section repair (see page 19).

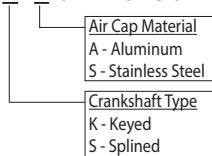

**637556** for Pump Crankcase seals service kit (see page 19).

**637557** for Oil and Filter replacement (see page 22).

**67558** for Oil piston pump assembly (see page 22).

### 9. SUBSYSTEM OVERVIEW

#### PARTS LIST / FLUID SECTION EB20-XXXXX-XXX-XXXX

##### Fluid Section Service Kits:

★ 637555-XX Fluid Section Service Kits include: Balls (see BALL Option, refer to -XX in chart below), Diaphragms (see DIAPHRAGM Option, refer to -XX in chart below), and items 3, 4, 12 and 13 (listed below).

##### EXTERNAL HARDWARE OPTIONS EB20-XXXXX-XXX-XXX

Item	Description	Qty	Aluminum / Cast Iron		Stainless Steel	
			Part No.	Mtl	Part No.	Mtl
26	Screw (M10 x 1.5 - 6g x 30 mm)	(12)	Y255-102-E	[C]	----	---
	Flange Screw (M10 x 1.5 - 6g x 30 mm)	(12)	----	---	95884	[SS]
27	Bolt (M10 x 1.5 - 6g x 45mm)	(30)	Y255-105-E	[C]	----	---
	Flange Bolt (M10 x 1.5 - 6g x 45mm)	(30)	----	---	94990	[SS]
28	Flat washer (M10)	(42)	98214	[C]	---	--
29	Flange Nut (M10 x 1.5 - 6H)	(30)	98217	[C]	94992	[SS]
68	Screw (M10 x 1.5 - 6g x 30 mm)	(16)	Y255-102-E	[C]	----	---
	Flange Screw (M10 x 1.5 - 6g x 30 mm)	(16)	----	---	95884	[SS]
69	Flat washer (M10)	(16)	98214	[C]	---	--

##### COMMON PARTS

Item	Description	Qty	Part No.	Mtl
9	Washer	(3)	98213	[SS]
★ 12	Diaphragm, Soft Washer	(3)	98026	[SP]
★ ⊙ 13	Bellows	(3)	97868-2	[V]
14	Screw (M16-2 x 70 mm)	(3)	98207	[SS]
⊙ 16	Bellows Plate	(3)	97864-2	[SS]
⊙ 17	Screw (M5 x 0.8 - 6g x 10 mm)	(12)	98057	[SS]
18	Spacer, Piston	(3)	98039	[C]
20	Roll Pin (1/8" x 0.5" length)	(6)	Y178-37-S	[SS]

⊙ Indicate parts included in Pump Crankcase Replacement Assembly, see page 19.

##### SEAT OPTIONS EB20-XXXXX-XXX-XXX

"21"							
-XXXXX	Seat	Qty	Mtl	-XXXXX	Seat	Qty	[Mtl]
-XXAXX	95825-A	(6)	[Sp]	-XXHXX	95891	(6)	[SH]
-XXFX	95892	(6)	[A]	-XXSXX	95877	(6)	[SS]

##### BALL OPTIONS EB20-XXXXX-XXX-XXX

★ "22" (2" dia.)							
-XXXXX	Ball	Qty	Mtl	-XXXXX	Ball	Qty	Mtl
-XXXAX	95826-A	(6)	[Sp]	-XXXTX	95826-4	(6)	[T]
-XXXSX	95878	(6)	[SS]	-XXXVX	95826-3	(6)	[V]

NOTE: Seat Option -XXAXX does not require item 19 "O" ring.

##### DIAPHRAGM OPTIONS EB20-XXXXX-XXX-XXX

Item	Description	QTY	Santoprene® Diaphragm EB-XXXXA		PTFE Diaphragm EB-XXXXT	
			Part No.	[Mtl]	Part No.	[Mtl]
★ 7	Diaphragm - Primary	(3)	97973-A	[Sp]	97975	[T]
★ 8	Diaphragm - Secondary	(3)	97974-A	[Sp]	97976-A	[Sp]
★ 10	Diaphragm - Tertiary	(3)	----	---	97977-A	[Sp]

##### FLUID SECTION SERVICE KIT

-XXXXX	★ Service Kit
	-XX = Ball
	-XX = Diaphragm
	637555-XX

##### MANIFOLD / FLUID CAP MATERIAL OPTIONS EB20-XXXXX-XXX-XXX

Item	Description	Qty	Aluminum EB20-AXXXX		Cast Iron EB20-CXXXX		Stainless Steel EB20-SXXXX	
			Part No.	[Mtl]	Part No.	[Mtl]	Part No.	[Mtl]
5	Backup Washer	(3)	98038-3	[C]	98038-3	[C]	98038-1	[SS]
6	Fluid Washer	(3)	98037-3	[C]	98037-3	[C]	98037-1	[SS]
15	Fluid Cap	(3)	97960	[A]	98090	[CI]	98091	[SS]
60	Manifold, Inlet Wye	(1)	98045	[A]	98069	[CI]	98083	[SS]
61	Manifold, Outlet Wye	(1)	98046	[A]	98070	[CI]	98085	[SS]
62	Manifold, Outlet Straight	(1)	98043	[A]	98068	[CI]	98082	[SS]
63	Manifold, Outlet PRV Wye	(1)	98042	[A]	98067	[CI]	98081	[SS]
64	Manifold, Inlet Straight	(1)	98040	[A]	98065	[CI]	98078	[SS]
65	Manifold, Inlet PRV Wye	(1)	98041	[A]	98066	[CI]	98079	[SS]

##### MATERIAL CODE

[A]	= Aluminum
[B]	= Nitrile
[Br]	= Brass
[C]	= Carbon Steel
[CI]	= Cast Iron
[Co]	= Copper
[D]	= Acetal
[EP]	= EPDM
[F]	= FEP
[H]	= Hytrel®
[NEP]	= Neoprene
[Ny]	= Nylon
[P]	= Polypropylene
[PU]	= Polyurethane
[SH]	= Hard Stainless Steel
[SP]	= Santoprene®
[SS]	= Stainless Steel
[T]	= PTFE
[V]	= Viton®

##### O-RING OPTIONS EB20-XXXXX-XXX-XXX

Item	Description	Qty	Santoprene® Diaphragm EB20-XXXXA		PTFE Diaphragm EB20-XXXXT		Part List
			Part No.	[Mtl]	Part No.	[Mtl]	
★ 3	O - Ring (1/16" x 3/4" OD) - Secondary	(3)	Y327-16	[V]	Y327-16	[V]	Page 13
★ 4	O - Ring (1/16" x 3/4" OD) - Primary	(3)	Y327-16	[V]	Y328-16	[T]	Page 13
★ 19	O - Ring (1/8" x 3-1/8" OD)	(6)	95992	[EP]	Y328-233	[T]	Page 13
67	O - Ring (1/8" x 2-5/8" OD)	(4)	Y323-229	[EP]	Y324-229	[F]	Page 13

**PARTS LIST / FLUID SECTION EB20-XXXXX-XXX-XXX**

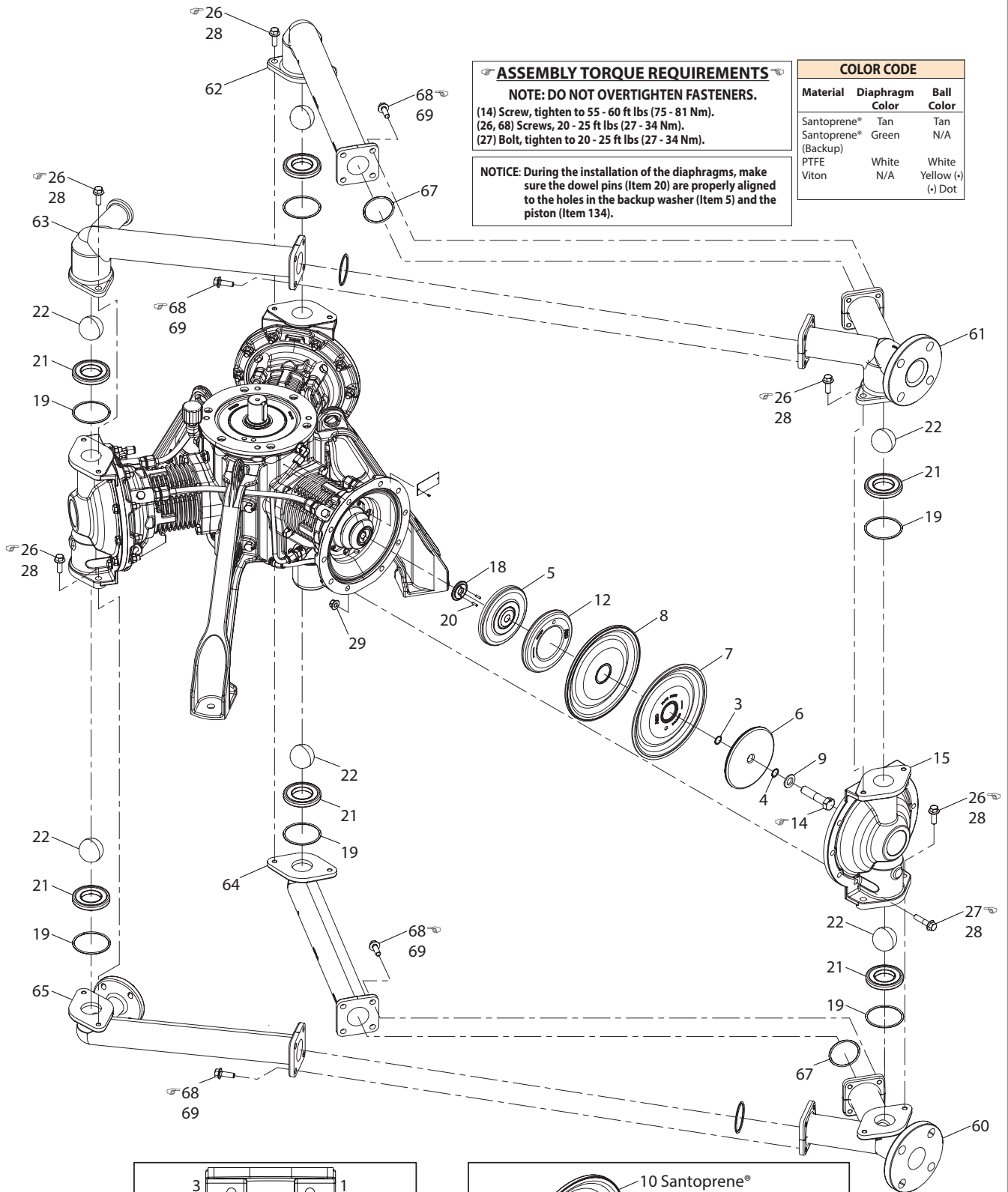

**ASSEMBLY TORQUE REQUIREMENTS**  
**NOTE: DO NOT OVERTIGHTEN FASTENERS.**  
 (14) Screw, tighten to 55 - 60 ft lbs (75 - 81 Nm).  
 (26, 68) Screws, 20 - 25 ft lbs (27 - 34 Nm).  
 (27) Bolt, tighten to 20 - 25 ft lbs (27 - 34 Nm).

**NOTICE:** During the installation of the diaphragms, make sure the dowel pins (Item 20) are properly aligned to the holes in the backup washer (Item 5) and the piston (Item 134).

COLOR CODE		
Material	Diaphragm Color	Ball Color
Santoprene®	Tan	Tan
Santoprene® (Backup)	Green	N/A
PTFE	White	White
Viton	N/A	Yellow (-) (-) Dot

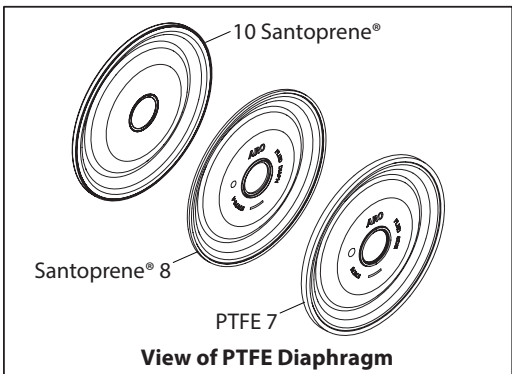
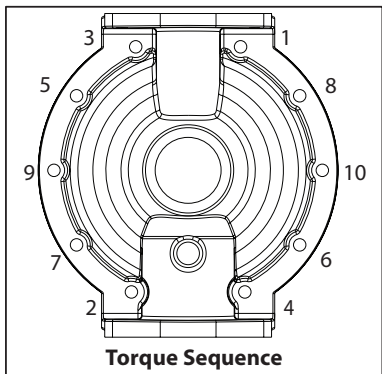

**Figure 4**

## FLUID SECTION DISASSEMBLY

- Remove inlet Manifolds (60, 64, 65) and outlet Manifolds (61, 62, 63) together.
- Separate inlet wye Manifold (60), Inlet PRV Manifold (65) and Inlet Straight Manifold(64).
- Separate outlet wye Manifold (61), outlet PRV Manifold (63) and Outlet Straight Manifold(62).
- Remove O-ring (67) between Manifold flanges.
- Remove (22) balls, (19) "O" rings and (21) seats.
- Remove (15) fluid caps.

**NOTE:** Bilayer Diaphragm used primary Diaphragm (7) and backup Diaphragm (8). PTFE Diaphragm models use a primary Diaphragm (7) and a bilayer backup Diaphragm (8 and 10). Refer to the auxiliary view in the Fluid Section illustration.

- Remove Diaphragm bolt (14), washer (9), outer Diaphragm washer (6), primary Diaphragm (7), back up Diaphragm (8 and 10), Inner Diaphragm washer (5), Diaphragm soft pad (12), spacer (18).
- Remove Bellows plate (16) and Bellows (13).

**NOTE:** Do not scratch or mark the surface of Piston rod (134).

## FLUID SECTION REASSEMBLY

- Reassemble parts in reverse order from the sequence in which they were removed. Refer to the torque requirements on page 13.
- Clean and inspect all parts. Replace worn or damaged parts with new parts as required.
- Install Bellows (13), Bellows plate (16) and secure with socket head screw (17).
- Diaphragms should be installed as marked and should be concave towards Fluid cap (15). "Fluid side" marking should face fluid cap. "Drive side" marking should face Crankcase.
- Install Spacer (18), Diaphragm soft pad (12), Inner Diaphragm washer (5), primary Diaphragm (7), back up Diaphragm (8 and 10), outer Diaphragm washer (6), screw washer and secure it with Diaphragm bolt (14). Ensure O-ring (3) is placed onto bore seal and O-ring (4) is placed onto face seal groove of outer Diaphragm washer (6)
- Install Fluid cap (15) through hex head bolt (27) and nut (29).
- Install (21) seats, (19) "O" rings and (22) balls.
- Assemble outlet wye Manifold (61) to outlet PRV Manifold (63) and Outlet Straight Manifold (62) and secure with hex head bolt (68). Ensure O-ring (67) is placed between Manifolds
- Assemble inlet wye Manifold (60) to Inlet PRV Manifold (65) and Inlet Straight Manifold (64) and secure with hex head bolt (68). Ensure O-ring (67) is placed between Manifolds.
- Install inlet Manifold assembly (60, 64, 65) and outlet Manifold assembly (61, 62, 63) and secure with hex head bolt (26).

**NOTE:** Washer (28, 69) is used for Aluminum and Cast Iron pump configuration.

- Re-check torque settings after pump has been restarted and run awhile.

**PARTS LIST / PRV EB20-XFXXX-XXX-XXX****PRV O-RING OPTIONS EB20-XFXXX-XXX-XXX**

Item	Description	Qty	Santoprene Diaphragm		PTFE Diaphragm		Part List
			Part No.	[Mtl]	Part No.	[Mtl]	
❖ 41	O-Ring (3/16" x 1-3/8" OD) - Primary	(2)	Y323-123	[EP]	Y324-123	[F]	Page 17
❖ 59	O-Ring (3/16" x 1-3/8" OD) - Secondary	(2)	Y323-123	[EP]	Y327-123	[V]	Page 17
❖ 58	O-Ring (1/8" x 2" OD)	(1)	Y323-224	[EP]	Y324-224	[F]	Page 17

**MANIFOLD / HOUSING MATERIAL OPTIONS EB20-XFXXX-XXX-XXX**

Item	Description	Qty	Aluminum		Cast Iron		Stainless Steel	
			Part No.	[Mtl]	Part No.	[Mtl]	Part No.	[Mtl]
40	PRV ASSY	(1)	67557-1	---	67557-2	---	67557-3	---
❖ 44	Housing, PRV	(1)	97971	[A]	98073	[CI]	98087	[SS]
66	Manifold, PRV Return	(1)	98048	[A]	98072	[CI]	98086	[SS]

**EXTERNAL HARDWARE OPTIONS EB20-XFXXX-XXX-XXX**

Item	Description	Qty	Aluminum / Cast Iron		Stainless Steel	
			Part No.	Mtl	Part No.	Mtl
❖ 46	Cylinder, PRV	(1)	97982-1	[C]	97982-2	[SS]
❖ 50	Cap Spring, PRV	(1)	97972-1	[C]	97972-2	[SS]
❖ 52	Bolt (M8 x 1.25 - 6g x 30 mm)	(5)	Y255-83-E	[C]	----	--
	Flange Bolt (M8 x 1.25 - 6g x 30 mm)		----	--	95880	[SS]
❖ 53	Flanged Top Lock Nut (M8 x 1.25)	(5)	98220	[C]	95879	[SS]
❖ 54	Washer (M8)	(5)	98215	[C]	----	--
55	Bolt (M10 x 1.5 - 6g x 45mm)	(4)	Y255-105-E	[C]	----	---
	Flange Bolt (M10 x 1.5 - 6g x 45mm)	(4)	----	---	94990	[SS]
56	Flat washer (M10)	(4)	98214	[C]	---	--
57	Flange Nut (M10 x 1.5 - 6H)	(4)	98217	[C]	94992	[SS]

**COMMON PARTS**

Item	Description	Qty	Part No.	Mtl
❖ 37	Clamp	(4)	93283	[SS]
❖ 38	Carriage Bolt (1/4" x 20 - 6g x 1-1/2")	(4)	Y84-403-T	[SS]
❖ 39	Nut (1/4" - 20)	(4)	Y12-4-S	[SS]
❖ 42	Bellows, PRV	(1)	97981	[T]
❖ 43	O-Ring (1/8" x 2-5/8" OD)	(1)	Y327-229	[V]
❖ 45	Rod, PRV	(1)	97980	[SS]
❖ 47	Piston, PRV	(1)	97979	[D]
❖ 48	O-Ring (3/16" x 2" OD)	(1)	Y327-326	[V]
❖ 49	Spring, PRV	(1)	97978	[C]
❖ 51	Fitting (3/8" OD Tube x 1/4" NPT)	(1)	59474-160	[Ny]
196	Tubing (3/8" OD Clear)	(0.6 ft)	98227-XXX-X	[F]

❖ Indicate parts included in PRV assembly 67557-X (40).

---

**PRV SECTION DISASSEMBLY**

---

- Disconnect 3/8" OD tube (196) between PRV cylinder (46) and air cap (147).
- Loosen clam shell (37) between PRV return Manifold (66) and PRV housing (44). Remove PRV return Manifold (66) from inlet PRV Manifold (65).
- Loosen clam shell (37) between outlet PRV Manifold (63) and PRV housing (44). Remove PRV housing (44).
- Remove PRV cap (50), spring (49), piston assembly (45 and 47), and O-ring (48).
- Remove PRV cylinder (46) from PRV housing (44).
- Remove Bellows (42) and O-ring (43) from PRV housing (44).

---

**PRV SECTION REASSEMBLY**

---

- Reassemble parts in reverse order from the sequence in which they were removed.
- Clean and inspect all parts. Replace worn or damaged parts with new parts as required.
- Assemble PTFE bellows (42) and O-ring (43) into PRV housing (44).
- Assemble PRV cylinder (46) to PRV Housing (44).
- Assemble O-ring (48) to piston assembly (45 and 47).
- Assemble piston assembly (45 and 47), spring (49) and PRV cap (50).
- Install O-ring (41) onto PRV housing (44) and PRV return Manifold (66).
- Assemble inlet of PRV housing (44) to Outlet PRV Manifold (63) and install clam shell (37) with carriage bolts (38) and nuts (39).
- Assemble outlet of PRV housing (44) to PRV return Manifold (66) and loosely install clam shell (37) with carriage bolts (38) and nut (39).
- Assemble PRV return Manifold (66) to inlet PRV Manifold (65) and ensure O-ring (58) is in place.
- Reconnect 3/8" OD tube (196) to push-to-connect fitting (51) installed in PRV cylinder (46).

**⚠ CAUTION** The PRV is intended only to protect the pump from rapid deadhead events and should not replace any system level protection that may be needed downstream of the pump.

**PARTS LIST / PRV EB20-XFXXX-XXX-XXX**

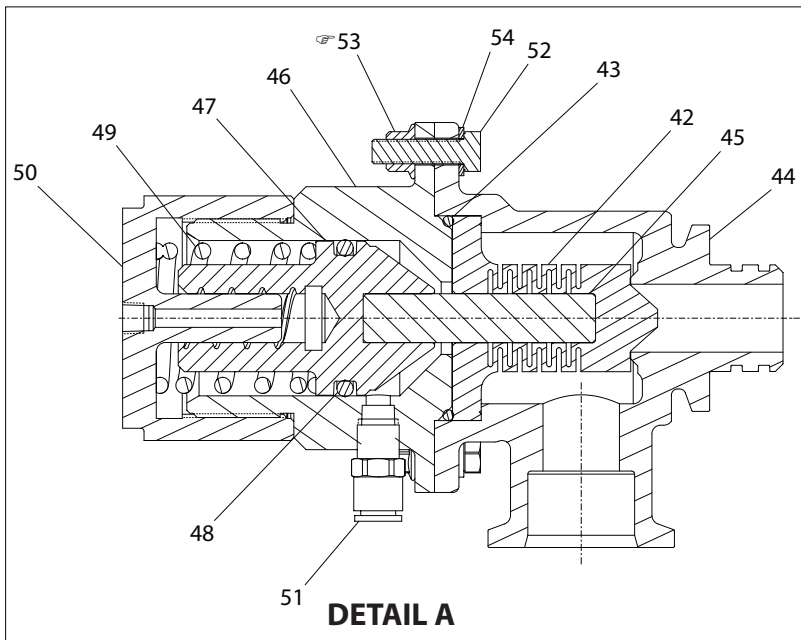
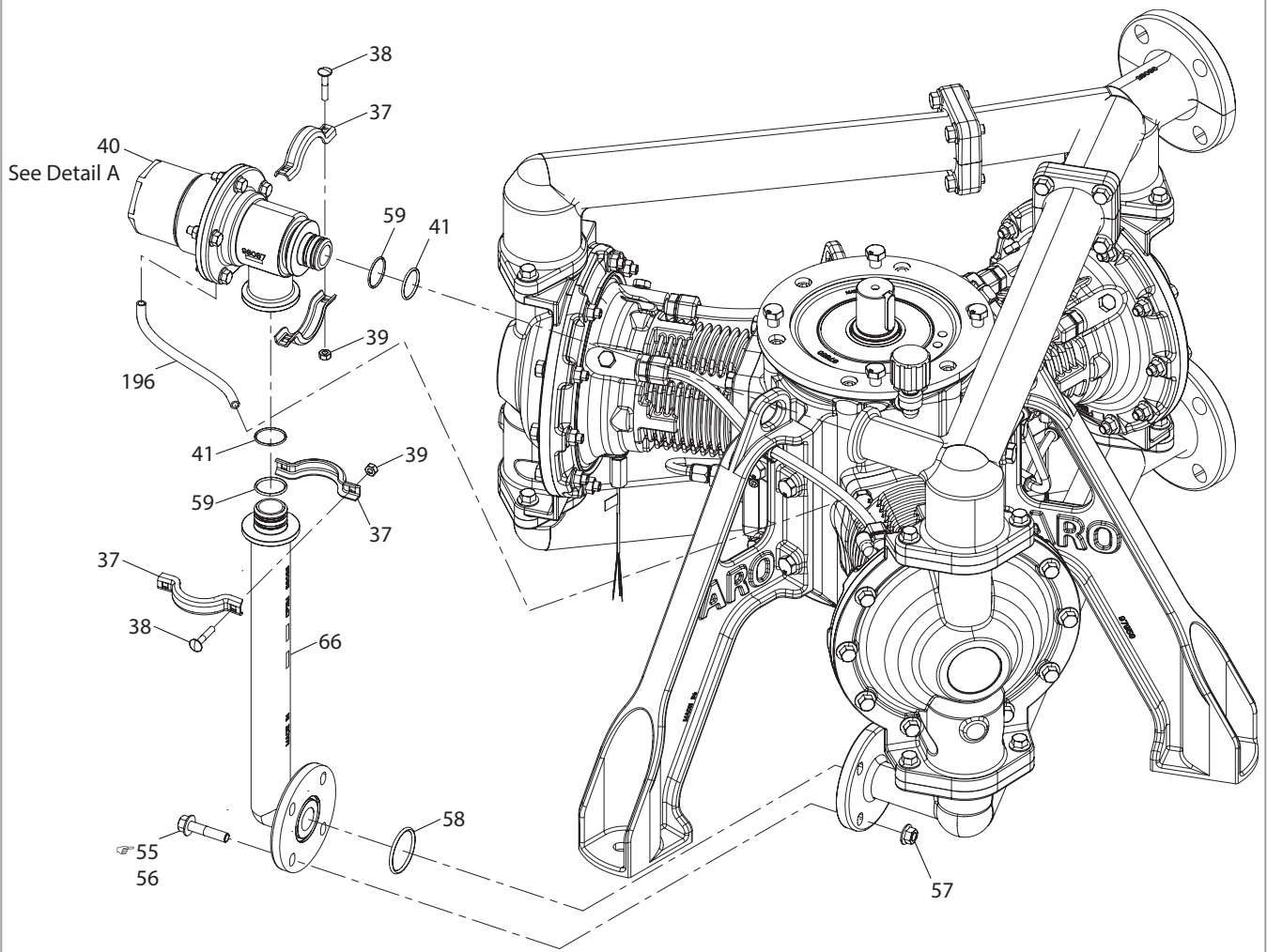

**ASSEMBLY TORQUE REQUIREMENTS**  
**NOTE: DO NOT OVERTIGHTEN FASTENERS.**  
 (53) Nut, tighten to 7 - 10 ft lbs (10 - 14 Nm).  
 (55) Bolt, tighten to 20 - 25 ft lbs (27 - 34 Nm).

**Figure 5**

**PARTS LIST / NO PRV EB20-XGXXX-XXX-XXX**

**NO PRV O-RING OPTIONS EB20-XGXXX-XXX-XXX**

Item	Description	Qty	Santoprene Diaphragm		PTFE Diaphragm	
			Part No.	[Mtl]	Part No.	[Mtl]
41	O-Ring (3/16" x 1-3/8" OD) - Primary	(1)	Y323-123	[EP]	Y324-123	[F]
59	O-Ring (3/16" x 1-3/8" OD) - Secondary	(1)	Y323-123	[EP]	Y327-123	[V]
58	O-Ring (1/8" x 2" OD)	(1)	Y323-224	[EP]	Y324-224	[F]

**MANIFOLD / HOUSING MATERIAL OPTIONS EB20-XGXXX-XXX-XXX**

Item	Description (size)	Qty	Aluminum		Cast Iron		Stainless Steel	
			Part No.	[Mtl]	Part No.	[Mtl]	Part No.	[Mtl]
70	PRV Inlet Plug	(1)	98349-1	[A]	98349-2	[CI]	98349-3	[SS]
71	PRV Outlet Plug	(1)	98352-1	[A]	98352-2	[CI]	98352-3	[SS]

**EXTERNAL HARDWARE OPTIONS EB20-XGXXX-XXX-XXX**

Item	Description	Qty	Aluminum / Cast Iron		Stainless Steel	
			Part No.	Mtl	Part No.	Mtl
55	Bolt (M10 x 1.5 - 6g x 45mm)	(4)	Y255-105-E	[C]	----	---
	Flange Bolt (M10 x 1.5 - 6g x 45mm)	(4)	----	---	94990	[SS]
56	Flat washer (M10)	(4)	98214	[C]	---	--
57	Flange Nut (M10 x 1.5 - 6H)	(4)	98217	[C]	94992	[SS]

**COMMON PARTS**

Item	Description	Qty	Part No.	Mtl
37	Clamp	(2)	93283	[SS]
38	Carriage Bolt (1/4" x 20 - 6g x 1-1/2")	(2)	Y84-403-T	[SS]
39	Nut (1/4" - 20)	(2)	Y12-4-5	[SS]
72	Plug (3/8" OD Tube)	(1)	59463-60	[Ny]

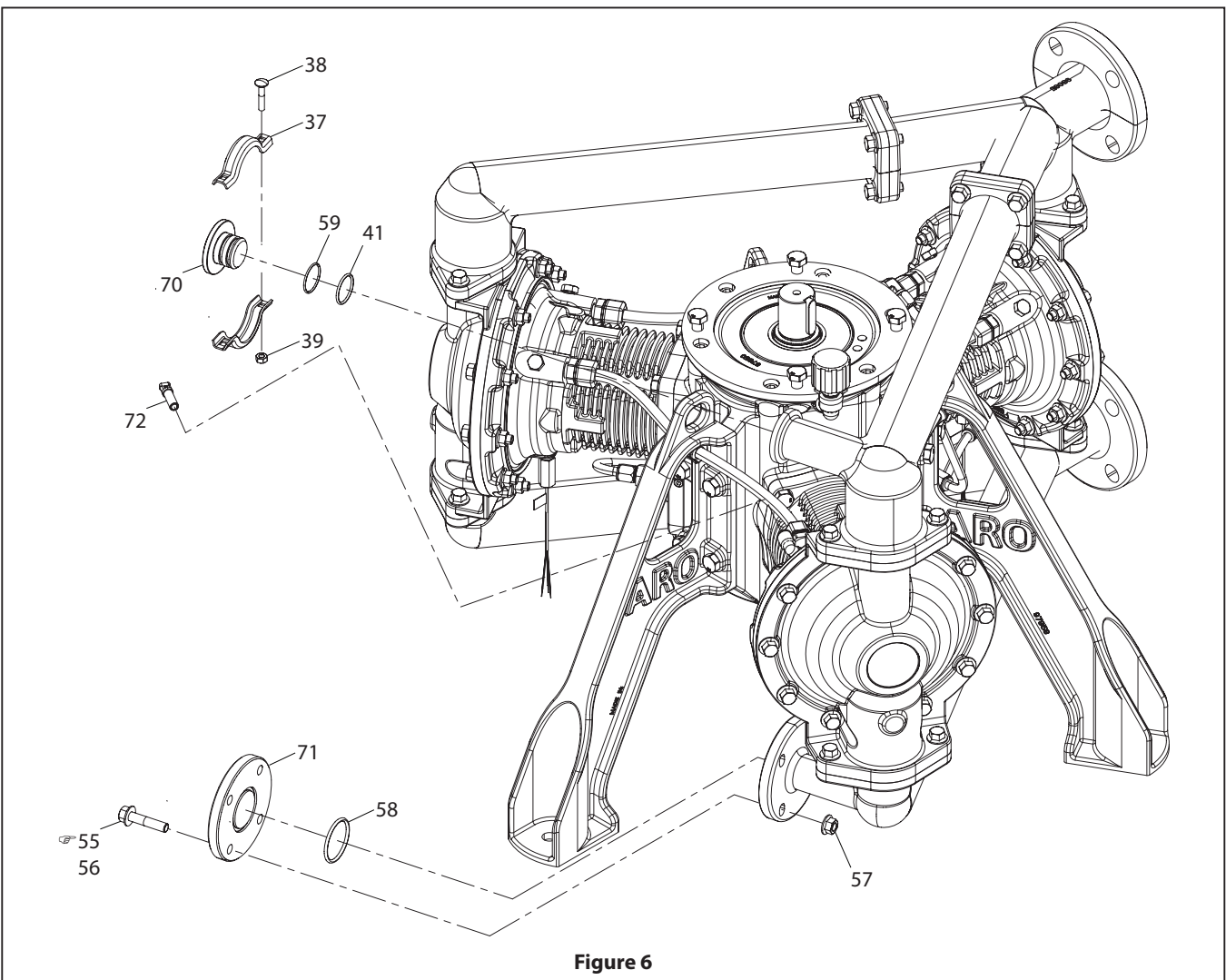

Figure 6

**PARTS LIST / CRANKCASE EB20-XXXXX-XXX-XXX**

© **Pump Crankcase Replacement Assembly EP20-CXVX-01-A:** Includes all Items shown in the Crankcase parts list (below) except for item 74 and 197. Includes all items shown in the oil pump parts list (page 22). Includes items 13, 16 and 17 shown on page 12.

**Note:** Crankcase components are designed for the intended life of the pump. Crankshaft bearings are press fit in place and are not individually available for aftermarket replacement.

Item	Description	Qty	Part No.	[Mtl]
74	Plug (1/4" NPT)	(3)	Y17-51-S	[SS]
101	Main Housing	(1)		[CI]
102	Housing Cap	(1)		[CI]
○ 103	O-Ring (1/8" x 7-3/4" OD)	(1)	Y325-264	[B]
104	Screw (M10 x 1.5 - 6g x 35 mm)	(6)	97997	[SS]
105	Leg	(3)	97958	[C]
106	Screw (M12 x 1.75 - 6g x 40 mm)	(12)	Y255-123-E	[C]
107	Bearing, Upper	(1)		[C]
108	Snap Ring (55 mm OD)	(1)	97956	[C]
109	Shaft Seal, Upper	(1)	98053	[B]
110	Shaft Sleeve, Upper	(1)		[SS]
111	Bearing, Lower	(1)		[C]
○ 112	Shaft Seal, Lower	(1)	97870	[B]
113	Shaft Sleeve, Lower	(1)		[SS]
114	Lower Cap	(1)	97869	[C]
115	Screw (M6 x 1 - 6g x 20 mm)	(3)	Y256-63-E	[C]
○ 116	O-Ring (1/8" x 1-3/4" OD)	(1)	Y325-222	[B]
○ 117	O-Ring (1/8" x 3-5/8" OD)	(1)	Y325-237	[B]
118	Crankshaft (Spline) (EB20-XXXXX-XXS-XXX)	(1)	67523	[C]
	Crankshaft (Keyed) (EB20-XXXXX-XXK-XXX)	(1)	67524	[C]
119	Bearing, Throw	(3)		[C]
120	Bearing, Spacer	(3)		[C]
121	Connecting Rod, Bearing-Side	(3)		[CI]
122	Roll Pin (M3 x 8 mm)	(6)	25M13EA213	[C]
124	Cam	(1)		[D]
125	Screw (M6 x 1 - 6g x 20 mm)	(2)	Y256-63-E	[C]
126	Breather (3/8"-18 NPT)	(1)	98178	[Ny]
127	Elbow (3/8" - 18 NPT)	(1)	98218	[Ny]
130	Cylinder	(3)	98182	[C]
131	Screw (M12 x 1.75 - 6g x 40 mm)	(12)	Y255-123-E	[C]
○ 132	O-Ring (1/8" x 5" OD)	(3)	Y325-248	[B]
133	Wear Sleeve	(3)	98183	[Ny]
134	Piston	(3)	98181-1	[C]
135	Wrist Pin	(3)	97873	[C]
136	Snap Ring (25mm ID)	(3)	161M13N25	[C]
137	Dowel Pin (M3 x 40 mm)	(3)	17M13B170	[C]

Item	Description	Qty	Part No.	[Mtl]
138	Screw (M4 x 0.7 - 6g x 8 mm)	(3)	119M2A126B	[C]
139	Wrist Pin Journal	(3)	98052	[Br]
140	Connecting Rod, Journal-Side	(3)	97855-1	[C]
141	Screw (5/16-18 x 1")	(6)	97867	[C]
142	Rider Band	(3)	98184	[Br]
○ 143	U-Cup Seal	(3)	97875	[PU]
144	Bushing, Vent	(3)	98180	[Ny]
○ 145	O-Ring (1/8" x 4-1/4" OD)	(3)	Y325-242	[B]
146	Screw (M12 x 1.75 - 6g x 30 mm) (EB20-XXXXX-XXX-XXX) (EB20-CXXXX-XXX-XXX)	(12)	Y256-122-E	[C]
	Screw (M12 x 1.75 - 6g x 30 mm) (EB20-SXXXX-XXX-XXX)	(12)	119M2H274	[SS]
147	Air Cap (EB20-XXXXX-XXX-XXX) (EB20-CXXXX-XXX-XXX)	(3)	97861	[A]
	Air Caps (EB20-SXXXX-XXX-XXX)	(3)	98088	[SS]
148	Roll Pin (M6 x 16 mm)	(7)	25M13EA467	[C]
180	Drain Plug (3/8"-18 NPT)	(1)	98062	[SS]
181	Fitting (3/8" OD Tube x 1/4" NPT 90° Elbow)	(3)	59756-160	[Ny]
182	Fitting (3/8" OD Tube x 1/4" NPT 45° Elbow)	(3)	98060	[Ny]
183	Fitting (1/2" OD Tube x 3/8" NPT)	(6)	98054	[P]
184	Tubing (3/8" OD) (Black)	(1.4 ft)	98225-XXX-X	[Ny]
185	Tubing (1/2" OD) (Black)	(3.6 ft)	98226-XXX-X	[Ny]
186	Grommet, Air Cap Tubing	(3)	98189	[NEP]
187	Ground Lug (1/4" - 20)	(1)	96878	[Co]
188	Fitting (3/8" OD Tube x 1/4" NPT 90° Elbow)	(1)	59756-160	[Ny]
189	Plug	(5)	98056	[P]
190	Sight Glass (1/2" - 14 NPT)	(1)	98061	[C]
192	Screw (M12 x 1.75 - 6g x 30 mm)	(4)	Y255-121-E	[C]
197	Crankshaft Key (8 x 12 x 45 mm)	(1)	97996	[C]
□ 200	Oil container (7.5 L) (Aftermarket Only)	(1)	67570	

□ Item 172 (see page 22) and Item 200 included in 637557 Oil and filter replacement kit.

○ Indicate parts included in 637556 Pump Crankcase Seal Service Kit shown above and items 151, 154, 156, 157 and 165 shown on page 22.

**CRANKCASE SERVICE**

- Crankcase section Service is continued from Fluid Section repair.
- Separate motor from pump.
- Inspect and replace old parts with new parts as necessary. Look for deep scratches on surfaces, and nicks or cuts in "O" rings.
- Take precautions to prevent cutting "O" rings upon installation.
- Lubricate "O" rings with crank case oil.
- Do not over-tighten fasteners, refer to torque specification block on view.
- Torque fasteners following restart.

**CRANKCASE DISASSEMBLY**

- Remove all flexible tube connection.
- Remove lower cap (114).
- Adjust Piston rod (134) position by rotating crank shaft (118) for ease in removing internal component.
- Remove Vent Bushing (144), Piston seal (143), Air cap (147), Piston wear ring (142), Cylinder(130).

**PARTS LIST / CRANKCASE EB20-XXXX-XXX-XXX**

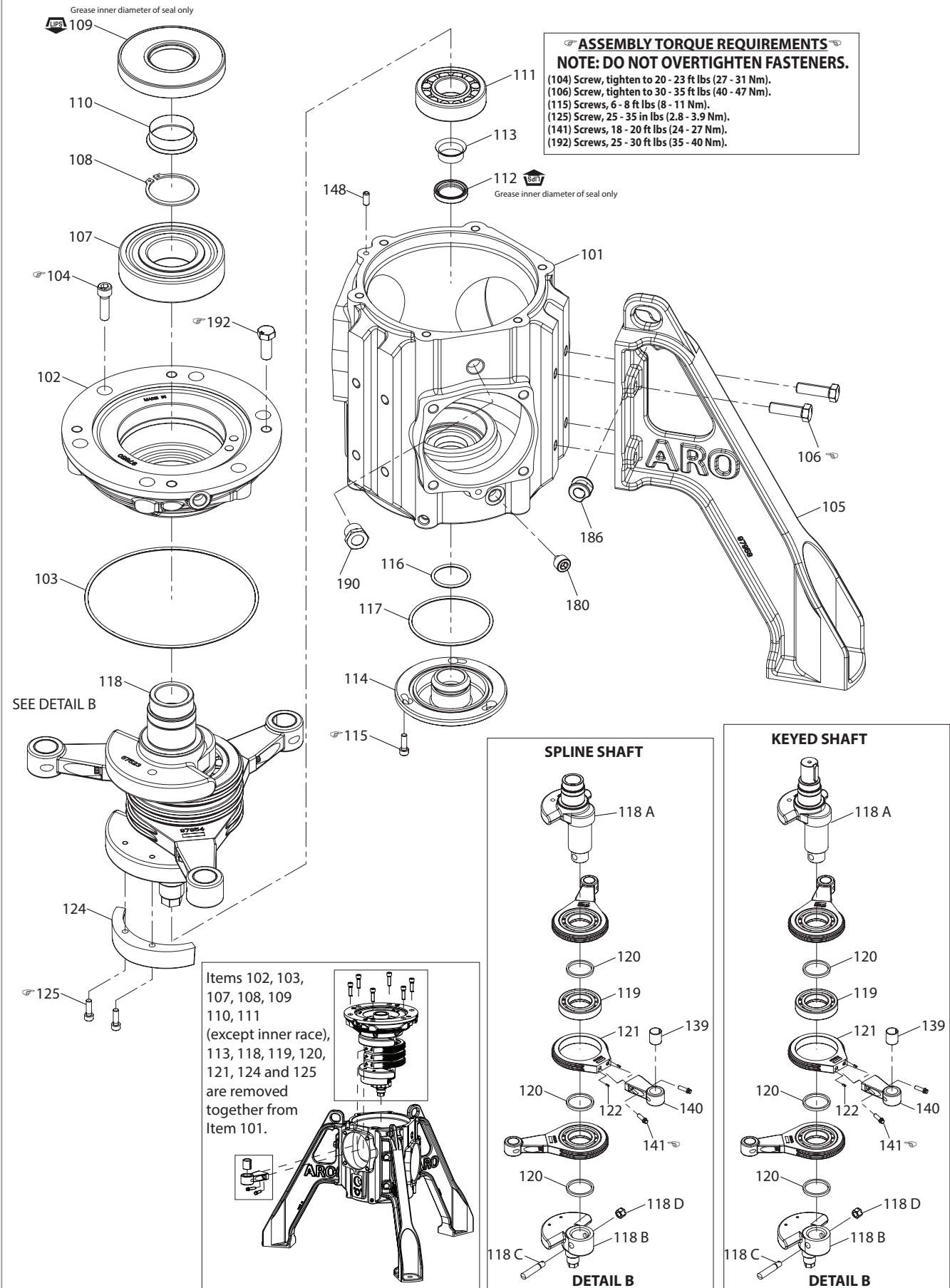

Figure 7

- Remove internal snap ring (136) and the wrist pin (135).
- Remove the piston rod (134) and rider band (133).
- Journal Bearing (139) is press fitted in to the connecting rod (140) from the factory. Remove the connecting rod (140) along with Journal (139).
- All bearing races are press fitted. However lower bearing (111) is separable between its Inner and outer race.
- Remove Housing cap (102), crank shaft assembly (118), Bearing housing (121) from Crankcase Housing (101).
- Ensure bearing housing (121) oriented in the same direction in order to remove from the Crankcase housing (101).

## CRANKCASE ASSEMBLY

- Reassemble parts in reverse order from the in a sequence in which they were are removed.
- Clean and inspect all parts. Replace worn or damaged parts with new parts as required.
- If cam (124) needs to be replaced. It should be serviced prior to installing the Crankshaft (118) into the housing (101).
- If wrist pin journal (139) needs to be replaced. It should be serviced prior to installing the connecting rod (140).
- To replace Journal (139), arbor press need to be use to press new Journal while simultaneously pushing out the old journal.
- Install lower shaft seal (112) into Crankcase housing (101). Ensure O-ring (103) is installed onto housing cap.

- Lower Crankshaft assembly vertically inside Crankcase housing (101) and allow inner race of lower bearing to gently engage with outer race. Secure housing cap to housing (101) with socket head screws (104).
- Install lower cap (114) and secure with socket head screws (115). Ensure O-rings (116 and 117) are installed onto the lower cap (114).
- Assemble each of the connecting rods (140) to bearing housings (121) securing with 12 point ferry cap head screws (141).
- Install wrist pin (135) to connect piston (134) to connecting rod (140). Ensure slotted side of wrist pin (135) is facing down and engages with dowel pin (137) to prevent rotation.
- Install retaining ring (136) to hold wrist pin (135) in place.
- Install rider band (133) onto the piston (134).
- Install cylinder (130) over piston (134) and secure to housing (101) with hex head screws (131). Ensure O-ring (132) is installed onto the cylinder (130).
- Install Piston wear ring (142), Piston seal (143), vent bushing (144), Bellows (13) and bellows plate (16) on to the air cap (147) and secure with socket head screws (17).
- Install air cap (147) to the cylinder (130) and secure with socket head screws (131). Ensure O-ring (145) is installed onto the air cap (147).

**NOTE:** Connecting rod housing (121) need to be oriented in the same direction to fit in the Crankcase housing (101).

## PARTS LIST / CRANKCASE EB20-XXXXX-XXX-XXX

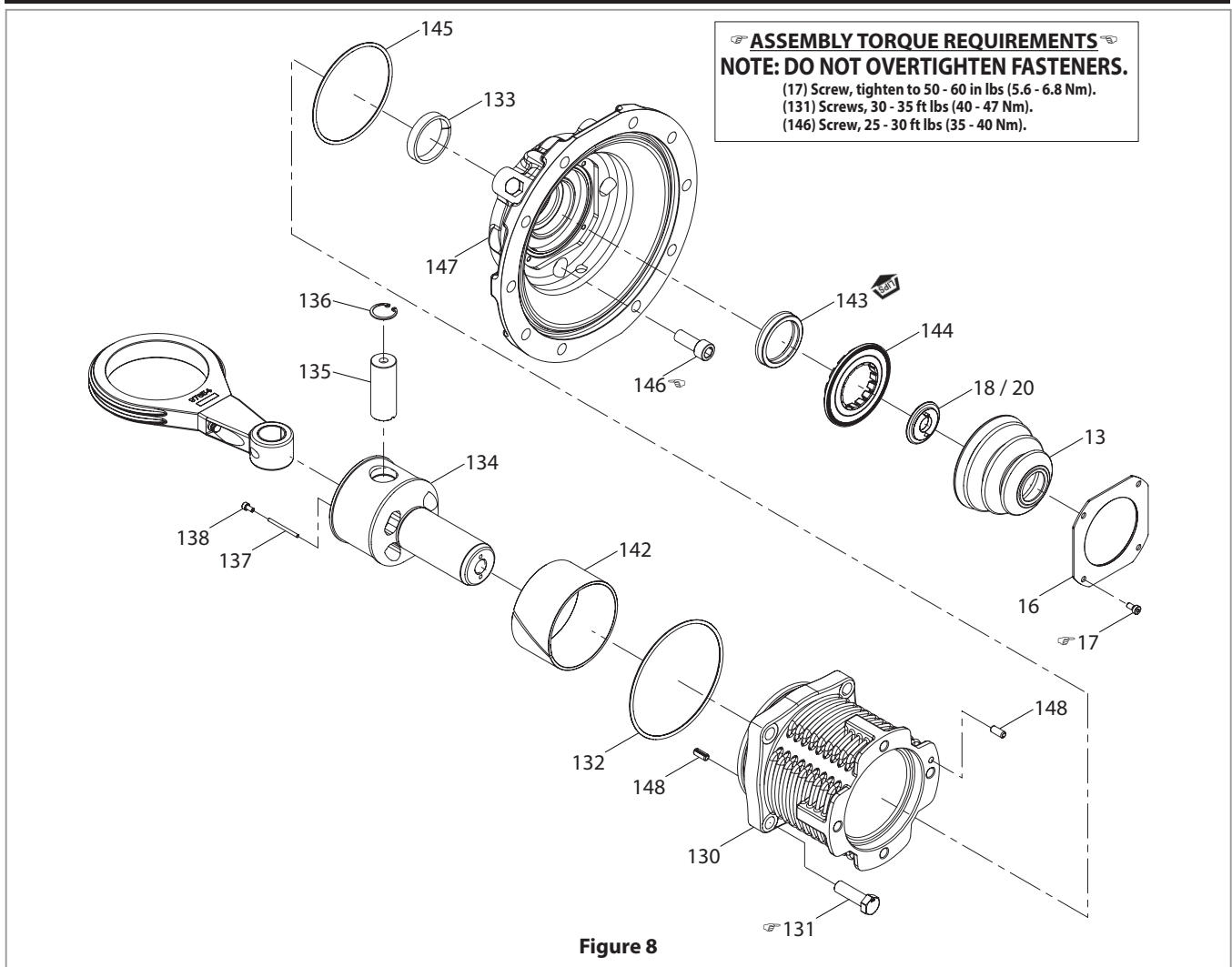

**PARTS LIST / OIL PISTON PUMP ASSEMBLY SECTION EB20-XXXX-XXX-XXX**

Item	Description	Qty	Part No.	[Mtl]
128	Plug (3/8" - 18 NPT)	(1)	Y17-52-S	[SS]
129	Fitting (9/16"-18 STOR x 3/8", 90°)	(1)	98059	[C]
149	Oil Pump Assy (Item include 150 to 170)	(1)	67558	
■ 150	Screw (M6 x 1 - 6g x 20 mm)	(2)	Y256-63-E	[C]
○ ■ 151	O-Ring (3/32" x 15/16" OD)	(1)	Y325-116	[B]
■ 152	Housing, Oil Return	(1)	98030	[C]
■ 153	Cylinder, Oil Pump	(1)	98028	[C]
○ ■ 154	O-Ring (3/32" x 1-9/16" OD)	(2)	Y325-126	[B]
■ 155	Outlet, Oil Pump	(1)	98029	[C]
○ ■ 156	O-Ring (3/32" x 1-1/8" OD)	(1)	Y325-119	[B]
○ ■ 157	O-Ring (3 mm x 36 mm OD)	(1)	97872	[B]
■ 158	Plug, Return	(1)	96610-1	[C]
■ 159	Piston, Oil Pump	(1)	98027	[C]
■ 160	Spring, Piston Return	(1)	98033	[C]
■ 161	Wrist Pin Journal (20 ID x 20 L)	(1)	98051	[Br]
■ 162	Ball	(1)	Y16-112	[C]
■ 163	Spring, Oil Relief	(1)	98034	[C]

Item	Description	Qty	Part No.	[Mtl]
■ 164	Plug (1/8" - 18 NPT ) (not shown)	(1)	Y17-50-S	[SS]
○ ■ 165	O-Ring (3/32" x 11/16" OD)	(1)	Y325-112	[B]
■ 166	Valve	(2)	48070	[D]
■ 167	Check Seat	(2)	48071	[H]
■ 168	Spring, Poppet Valve	(2)	98032	[C]
■ 169	Seat, Spring	(2)	98031	[A]
■ 170	Internal Snap Ring (16 mm)	(2)	97874	[C]
171	Oil Filter ASM	(1)	98063	[A]
□ 172	Oil Filter Element (Aftermarket Only)	(1)	98064	
173	Filter Bracket	(1)	97957	[C]
174	Screw (1/4" -20 x 0.5")	(2)	98211	[C]
175	Screw (1/4" -20 x 0.5")	(2)	98211	[C]
176	Fitting (9/16"-18 STOR x 3/8")	(2)	98058	[C]
177	Bent Tube, Post Filter (3/8" OD)	(1)	98050	[SS]
178	Bent Tube, Pre Filter (3/8" OD)	(1)	98049	[SS]
179	Fitting (3/4"-16 STOR x 3/8")	(1)	98055	[C]

- Indicate parts included in 67558 Oil piston pump replacement assembly.
- Indicate parts included in Pump Crankcase Seal Service Kit, see page 19.
- Indicate parts included in 637557 Oil and filter replacement kit, and item 200 shown on page 19.

**OIL REPLACEMENT**

**⚠ WARNING**

Dispose of oil according to any local regulatory requirements.

- Remove 3/8" NPT magnetic drain plug (Item - 180), from Crankcase housing below lowest cylinder.
  - Clean all foreign particles from the drain plug.
- Allow oil to drain from pump Crankcase to an approved oil container for disposal.
- Unscrew Filter element from filter head.
- Remove lower cap (Item - 114) for inspection of any oil leakage and replace the lower shaft seal (Item - 112) accordingly.
- Install new filter element.
  - Lubricate filter head threads.
  - Lubricate new oil filter gasket.
  - Hand screwed filter element to the head fully.
  - Extra half turn by external mean to make sure there is no oil leakage during pump operation.

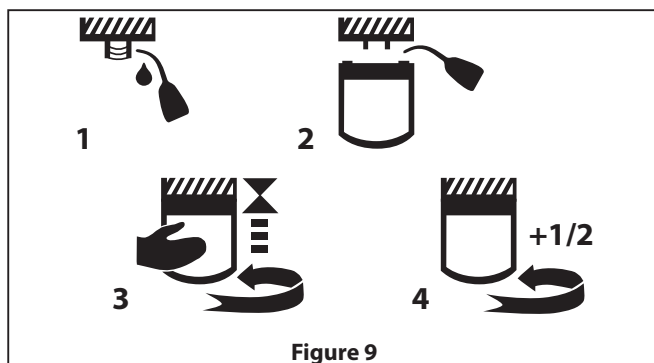

Figure 9

- Refill new oil to the Crankcase housing.

**DISASSEMBLY OIL FILTRATION**

- Ensure oil is drained from Crankcase housing (101) before disassembly.
- Loosen the compression fitting nuts (176, 129, 179) and remove tubing (177 and 178) from fittings.
- Remove the compression fittings (176) from oil filter (172).
- Remove the compression fitting (129) from Crankcase cap (102).
- Remove the compression fitting (179) from outlet of piston pump housing (155).
- Unscrew filter element (172) from filter head (171).
- Remove oil pump assembly (149).

**ASSEMBLY OIL FILTRATION**

- Reassemble parts in reverse order from the in a sequence in which they were removed.
- Look for deep scratches on surfaces, and nicks or cuts in "O" rings. Replace with new seals.
- Assemble oil pump assembly to the Crankcase housing (44).
- Assemble piston pump assembly (149) to oil pump return assembly. Ensure O-ring (151) is in place. Secure with socket head screws (150).
- Assemble Filter Head (171) to the oil filter bracket (173) and secure with hex head screws (174).
- Install 3/8" straight compression fittings (176) on both sides of filter head (172).
- Assemble filter element to the filter head.
- Assemble 3/8" straight compression fitting (179) to outlet of oil piston pump (155).
- Assemble 3/8" 90 degree compression fitting (129) to actuator cap (102).
- Assemble 3/8" OD metal tubing (177 and 178).

**PARTS LIST / OIL FILTER EB20-XXXXX-XXX-XXX**

**ASSEMBLY TORQUE REQUIREMENTS**  
**NOTE: DO NOT OVERTIGHTEN FASTENERS.**  
 (129, 176) Straight Thread O-Ring, tighten to 20-25 ft lbs (27-34 Nm)  
 (150) Screws, tighten to 6 - 8 ft lbs (8 - 11 Nm)  
 (174, 175) Screws, tighten to 40 - 50 in lbs (4.5 - 5.1 Nm)  
 (158) Plug, tighten to 45-50 ft lbs (61-68 Nm)  
 (179) Fitting Body, tighten to 45-50 ft lbs (61-68 Nm)

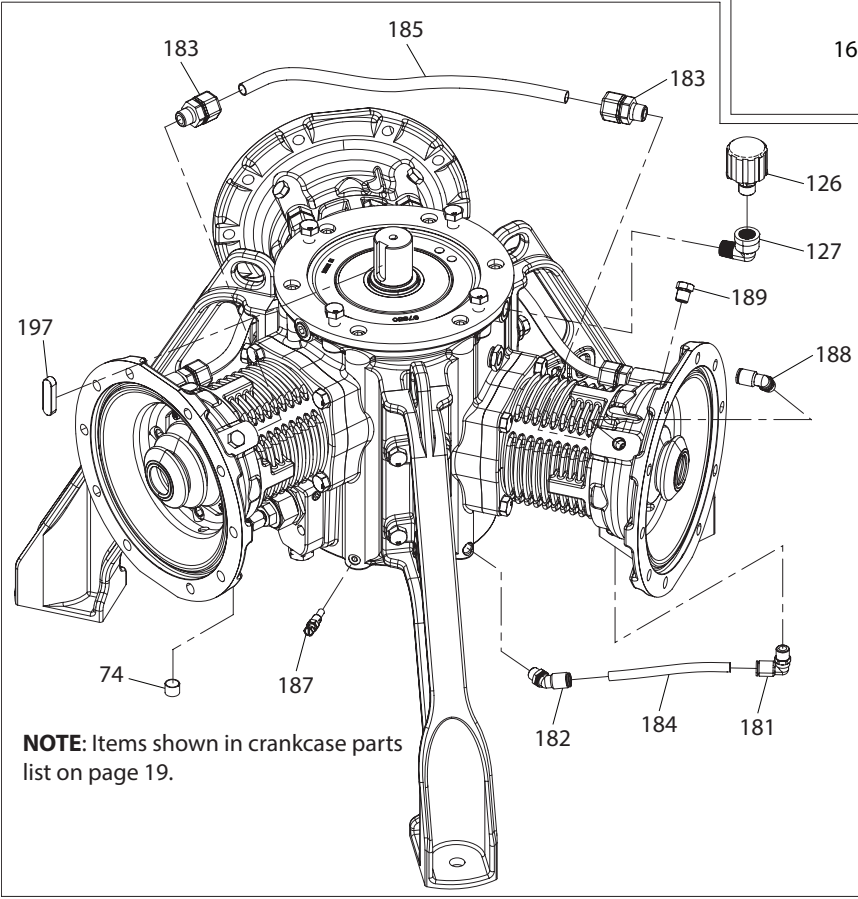
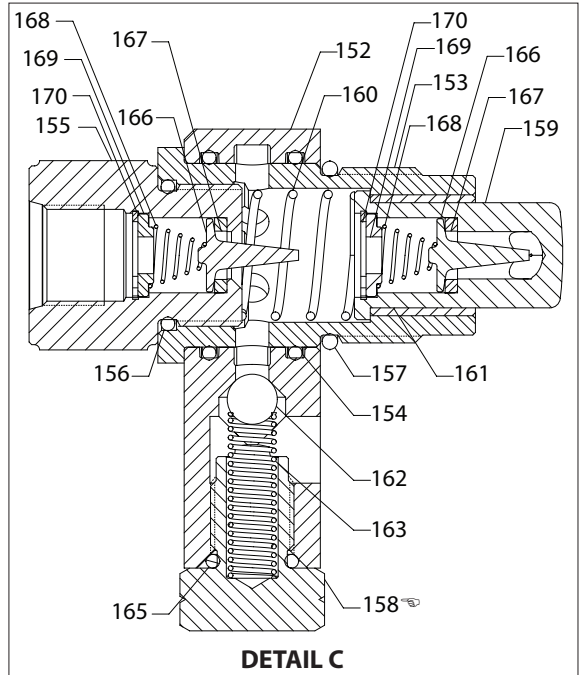
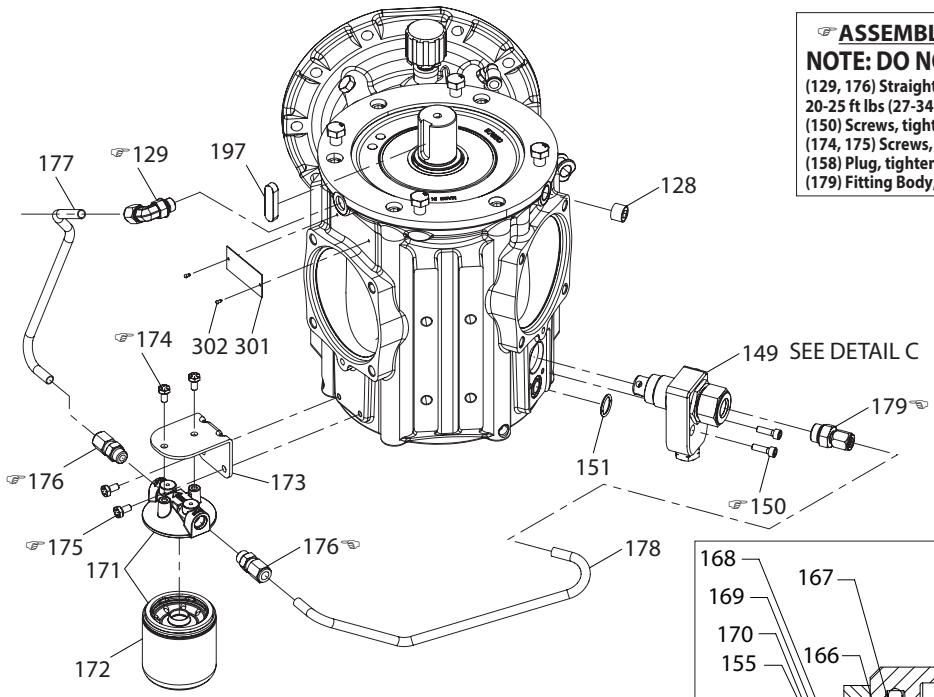

**NOTE:** Items shown in crankcase parts list on page 19.

**Figure 10**

## 10. TROUBLESHOOTING

Issue	Possible Cause	Action
Pump will not operate	Insufficient Torque	Increase torque to crankshaft
	Crankshaft bearing failure.	Replace pump Crankcase.
Erratic behavior or Excessive Noise / Knocking	Excessive wear of wrist pin and /or journal.	Replace wrist pin and journal.
	Excessive wear of piston rider band and/or wear ring.	Replace rider band and/or journal.
	Missing ball check or excessive ball check wear or failure.	Ensure ball checks are all installed, intact, and in place.
	System operating outside of NPSH requirements.	Ensure pump is running within NPSH requirements.
Pump will not achieve pressure	Foreign particle stuck in inlet Manifold or ball check.	Ensure no solid particles over solid passing capability are passed through the pump.
	Missing ball check or excessive ball check wear or failure.	Ensure ball checks are all installed, intact, and in place.
	Damage or failure of PRV bellows. (EB20-XFXXX-XXX-XXX Models Only)	Replace PRV Bellows.
Pump will not achieve flow	Insufficient Torque	Increase torque to crankshaft
	Missing ball check or excessive ball check wear or failure.	Ensure ball checks are all installed, intact, and in place.
Oil color turns black	Piston pump assembly is not functioning.	Bleed air from NPT plug on the top right side of oil pump housing.
	Crankshaft cam is broken or damaged.	Replace Crankshaft cam.
	Oil filter element needs to be replaced and is in bypass mode.	Replace oil and filter.
Pre-Mature Diaphragm Failure	Fluid cap bolts or Diaphragm bolt loosened allowing air in between Diaphragms.	Use recommended torques for all fasteners. Re-torque all fluid section bolts prior to operation.
PRV Bellows Failure	Pump PRV used for maintain system pressure spikes or shocks.	Pump PRV does not replace need for system safety or relief devices. Install system protection.
Rubber Bellows Failure	Bellows not replaced with each Diaphragm change.	Replace rubber bellows with each Diaphragm replacement.
	Excessive oil leak at piston seal limits breathing of rubber bellows and can collect in bellows.	Replace piston seals and piston if damaged.
Process Fluid Leak	Loose connections.	Use recommended torques for all fasteners. Re-torque all fluid section bolts prior to operation.
	Improper alignment of Manifolds, PRV, and fluid caps.	Follow recommended procedure from manual section 9 for proper alignment.
Excessive oil in outer section of lower cap, item 114	One or more of the reciprocating piston seals are worn or damaged.	Replace piston seal.
	Piston sealing surface is worn, scratched, or damaged.	Replace piston and seal.
	Excessive wear of piston wear ring or rider band.	Replace wear ring and rider band.
Excessive oil in inner section of lower cap, item 114	Shaft seal is worn or damaged.	Replace shaft seal.

## 11. DIMENSIONAL DATA

### 11.1 Pump (with or without PRV)

(Dimensions shown are for reference only, they are displayed in inches and millimeters (mm)).

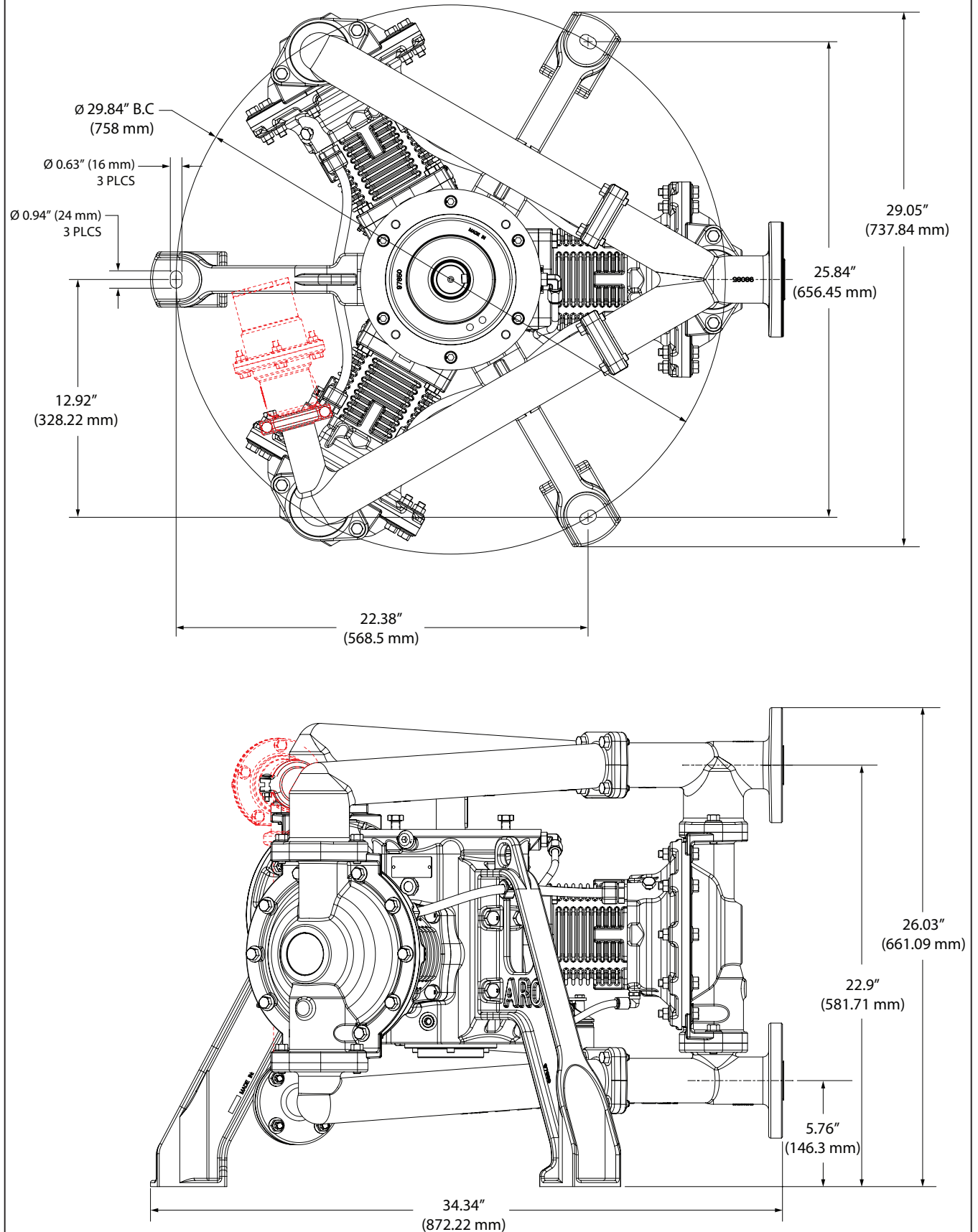
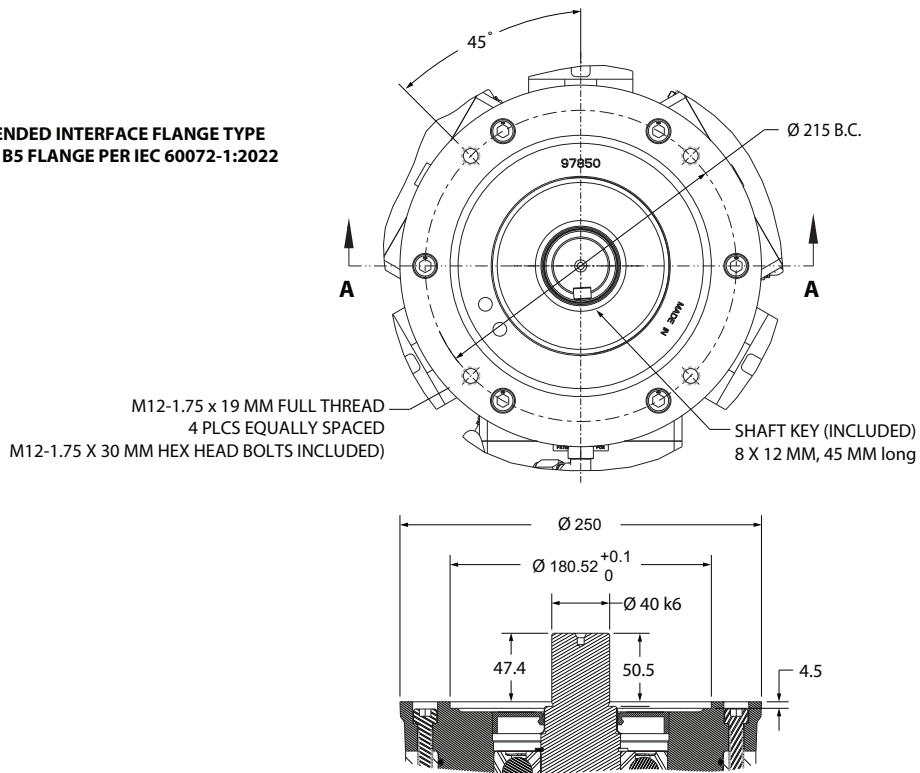

Figure 11

## 11.2. Pump interface details

### KEYED SHAFT

**RECOMMENDED INTERFACE FLANGE TYPE**  
250 Ø MM B5 FLANGE PER IEC 60072-1:2022



### SPLINE SHAFT

**RECOMMENDED INTERFACE FLANGE TYPE**  
250 Ø MM B5 FLANGE PER IEC 60072-1:2022

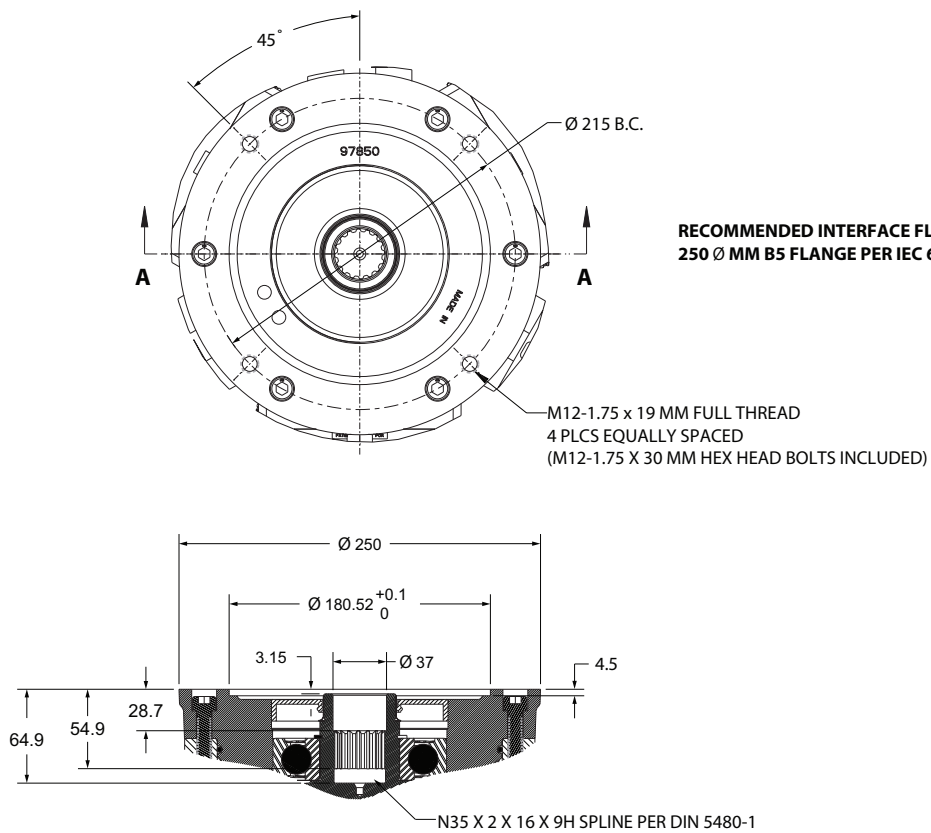
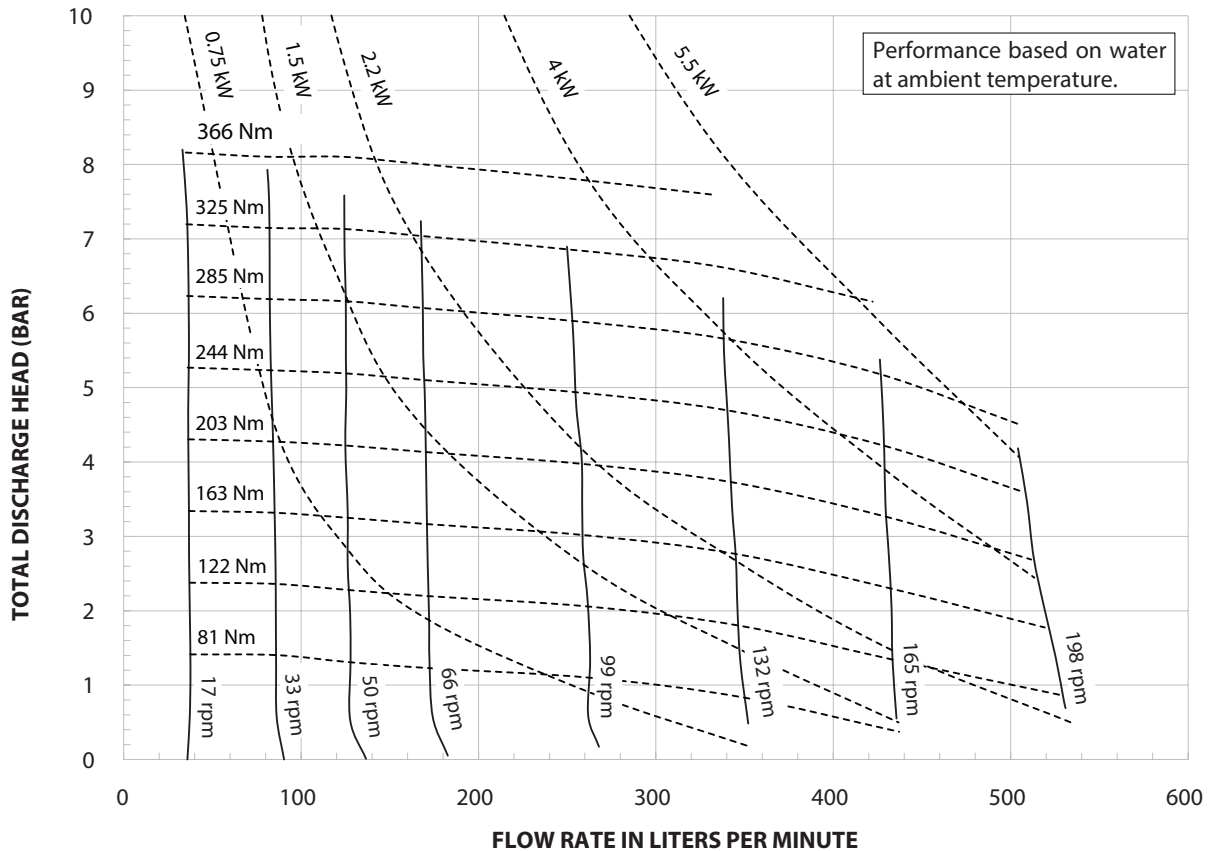
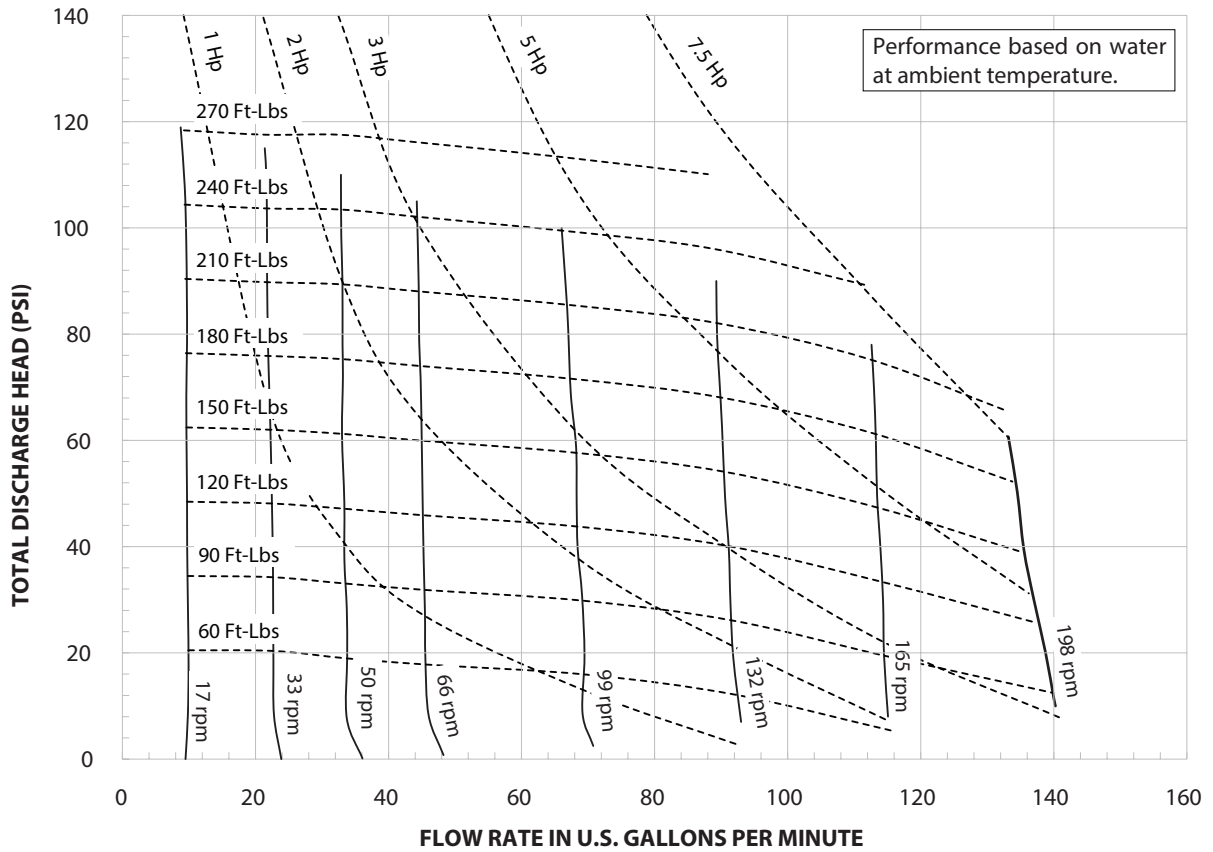

Figure 12

## 12. PERFORMANCE CURVE

### EB20-XXXXX-XXX-XXA 2" EVO DIAPHRAGM PUMP (METALLIC FLUID SECTION)



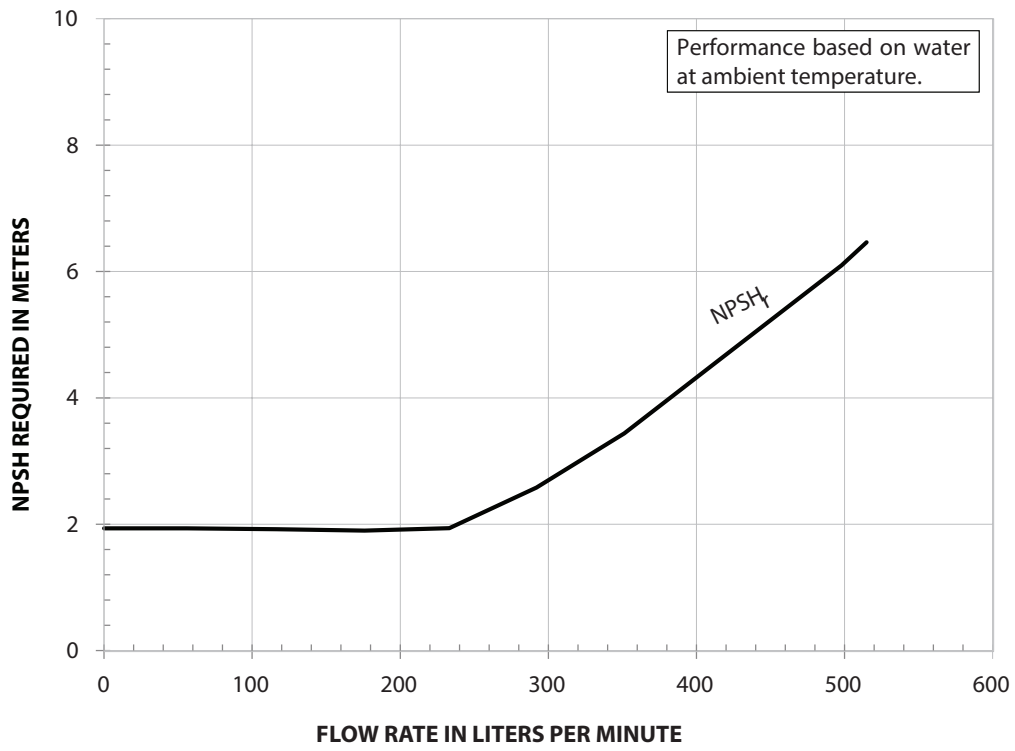
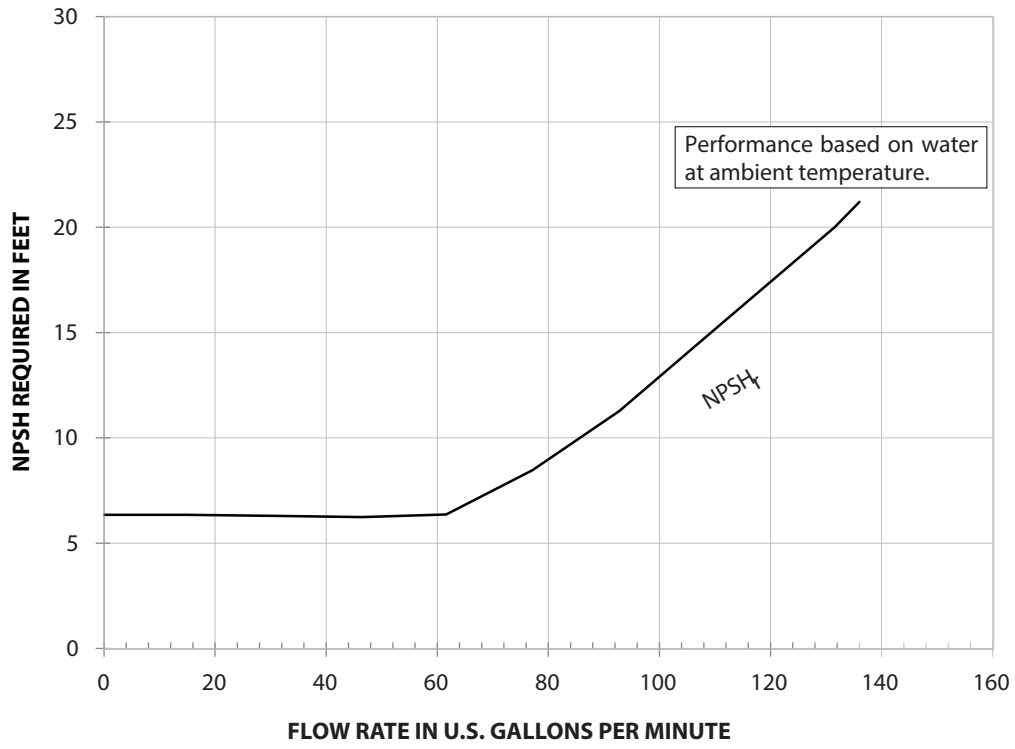

**NOTE:** When selecting a shaft coupling, it is recommended to multiply the average torque (the published value in the performance curves above) at the desired operating condition by a factor of 1.5 to account for peak torque oscillations above the average value. This does not take the place of any required safety factor.

### EB20-XXXXX-XXX-XXA 2" EVO DIAPHRAGM PUMP (METALLIC FLUID SECTION)



## 13. CERTIFICATION

### 13.1 Certification Standards and Markings

Description	Directive	Applicable Standards	Marking
Machinery Directive	2006/42/EC	EN ISO 12100:2010 EN 809:1998 + A1:2009	
RoHS Directive	2011/65/EU	EN IEC 63000:2018	
REACH Directive	1907/2006/EC		
ATEX Directive	2014/34/EU	EN ISO 80079 - 36:2016 EN ISO 80079 - 37:2016 EN IEC 60079 - 0:2018	

See 97999-2052 (S-1656, Declaration of Conformity)

#### Overview of hazardous location markings:

The non-electrical Ex h protection type used for the pump system is constructional safety type 'c'.

ATEX Marking	II 2G Ex h IIB T4 Gb II 2D Ex h IIIC T135°C Db
--------------	---

### 13.2 Specific Conditions of Use

1. During installation, equipment must be internally and externally grounded. Refer to instructions & maintenance manual grounding information.
2. Ambient temperature range  $(-18^{\circ}\text{C} \leq \text{Temp} \leq +40^{\circ}\text{C})$
3. Maximum temperature of the process fluid:  
+100 °C for EBX0-XXXXX-XXX-XXA; where X = A, C, or S

---

## 14. WARRANTY DECLARATION

---

Ingersoll-Rand/ARO®, through its Reseller, warrants the products to be free of defects in material and workmanship as determined by ARO® inspection, within (12) TWELVE MONTHS from the date of placing the product in operation with the initial end customer or (14) FOURTEEN MONTHS from the date of shipment, whichever occurs first. **Accordingly, the Warranty is not available for products purchased from unauthorized sellers, because IR cannot oversee or take action to correct product quality issues caused by unauthorized sellers.** This exclusion includes all products that are purchased from unauthorized sellers, including unauthorized Internet sites and unauthorized storefronts on online marketplaces.

Ingersoll-Rand/ARO® will provide a new part or repaired part, at its election, in place of any part which is found upon its inspection to be defective in material and workmanship during the period described above. Such part will be repaired or replaced without charge to the initial end customer during normal working hours at the place of business of a Reseller authorized to sell the type of Product involved or other establishment authorized by Company. Initial end customer must present proof of purchase (and purchase date) at the time of exercising this warranty and ship the product pre-paid authorized repair facility.

This warranty does not apply to wear parts, including but not limited to, pistons, oils, filters, diaphragms, balls, seats, washers, bellows, splines, PRV, bearings and/or manifolds without chemical attack/abrasion. This warranty also does not apply to failures occurring as a result of abuse, misuse, negligent repairs, corrosion, substitution of non-Ingersoll Rand / ARO® parts, erosion and normal wear and tear, alterations or modifications made to the Products without express written consent of Ingersoll-Rand/ARO®, or failure to follow the recommended operating practices and maintenance procedures as provided in the product's operating and maintenance publications.

**THIS WARRANTY IS IN LIEU OF ALL OTHER WARRANTIES (EXCEPT OF TITLE), EXPRESSED OR IMPLIED, AND THERE ARE NO WARRANTIES OF MERCHANTABILITY OR OF FITNESS FOR A PARTICULAR PURPOSE.**

The remedies of the initial end customer set forth under the provisions of warranty outlined above are exclusive. The total liability of Ingersoll-Rand/ARO®, or its Reseller, with respect to this sale or the Products and services furnished under this sale, in connection with the performance or breach of this warranty, or from the sale, delivery, installation, repair or technical direction covered by or furnished under this sale, whether based on contract, warranty, negligence, indemnity, strict liability or otherwise shall not exceed the purchase price of the unit or Products upon which such liability is based.

**INGERSOLL RAND/ARO® AND ITS RESELLER SHALL IN NO EVENT BE LIABLE TO THE INITIAL END CUSTOMER, ANY SUCCESSORS IN INTEREST OR ANY BENEFICIARY OR ASSIGNEE RELATING TO THIS SALE FOR ANY CONSEQUENTIAL, INCIDENTAL, INDIRECT, SPECIAL OR PUNITIVE DAMAGES ARISING OUT OF THIS SALE OR ANY BREACH THEREOF, OR ANY DEFECTS IN, OR FAILURE OF, OR MALFUNCTION OF THE PRODUCTS UNDER THIS SALE WHETHER BASED UPON LOSS OF USE, LOST PROFITS OR REVENUE, INTEREST, LOST GOODWILL, WORK STOPPAGE, IMPAIRMENT OF OTHER GOODS, LOSS BY REASON OF SHUTDOWN OR NON-OPERATION, INCREASED EXPENSES OF OPERATION, COST OF PURCHASE OF REPLACEMENT POWER OR CLAIMS OF USER OR CUSTOMERS OF THE USER FOR SERVICE INTERRUPTION WHETHER OR NOT SUCH LOSS OR DAMAGE IS BASED ON CONTRACT, WARRANTY, NEGLIGENCE, INDEMNITY, STRICT LIABILITY OR OTHERWISE.**



**About Ingersoll Rand**

Ingersoll Rand Inc. (NYSE:IR), driven by an entrepreneurial spirit and ownership mindset, is dedicated to helping make life better for our employees, customers and communities. Customers lean on us for our technology-driven excellence in mission-critical flow creation and industrial solutions across 40+ respected brands where our products and services excel in the most complex and harsh conditions. Our employees develop customers for life through their daily commitment to expertise, productivity and efficiency. For more information, visit [www.IRco.com](http://www.IRco.com)

In order to see updated information about ARO® or clarify any commercial or technical doubt, please visit [www.arozone.com](http://www.arozone.com)  
All brands and models have been registered and patents applied for.  
We reserve to the right to make changes without previous notice.

ARO® is a registered brand of Ingersoll Rand Company Inc. EVO Series™ is a trademark of Ingersoll Rand Company.

©2024 Ingersoll Rand. This material may not be reproduced without prior authorization.

We are committed to using environmentally conscious print practices

