

BALDOR® • *RELIANCE*

Product Information Packet

ECP2402T-4

10HP,880RPM,3PH,60HZ,284T,1060M,TEFC,F1

Part Detail							
Revision:	U	Status:	PRD/A	Change #:		Proprietary:	No
Type:	AC	Prod. Type:	1060M	Elec. Spec:	10WGY680	CD Diagram:	CD0006
Enclosure:	TEFC	Mfg Plant:		Mech. Spec:	10H292	Layout:	10LYH292
Frame:	284T	Mounting:	F1	Poles:	08	Created Date:	12-30-2010
Base:	RG	Rotation:	R	Insulation:	F	Eff. Date:	10-25-2016
Leads:	3#12					Replaced By:	
Literature:		Elec. Diagram:					

Nameplate NP3241											
CAT.NO.	ECP2402T-4	P/N		ENCLOSURE	TEFC						
SPEC.	10H292Y680	CC	010A	FRAME	284T	S/N					
HP	10	CLASS	F	HZ	60	DES	B				
RPM	880	RPM MAX	1325	PH	3	KVA-CODE	G				
VOLT	460	MOTOR WEIGHT	455								
AMP	14.4	SER.F.	1.15	PF	72	ODE BRG	6311	DE BRG	6311		
RATING	40C AMB-CONT	NEMA-NOM-EFF	90.2	GREASE	POLYREX EM						
				INV.TYPE	PWM						
TEMP CODE	T3A	INVERTER-TEMP-CODE	180								
TEMP =	180	C HP FR	60	C HP TO	90						
CT HZ FROM	6	CT HZ TO	60								
HTR-VOLTS		HTR-AMPS		HTR-WATTS		MAX. SPACE HEATER TEMP.		VT HZ FROM	3	VT HZ TO	60

Parts List		
Part Number	Description	Quantity
SA214271	SA 10H292Y680	1.000 EA
RA201482	RA 10H292Y680	1.000 EA
09FN3001C02	EXTERNAL FAN, PLASTIC	1.000 EA
10CB1000A09P	CONDUIT BOX, MACH W/EPOXY PRIMER	1.000 EA
09GS1010	GASKET, DWG, LEADWIRE SEPERATOR	1.000 EA
10XN3118K16	5/16-18 X 1' GRADE #5, STL, ZINC PLATE	4.000 EA
HW1001A31	LOCKWASHER 5/16, ZINC PLT.591 OD, .319 I	4.000 EA
10CB1503A01P	CONDUIT BOX LIPPED LID, MACH W/EPXY PRMR	1.000 EA
WD1000B16	T&B CX70TN TERMINAL	1.000 EA
10XN2520K06	1/4-20 X 3/8" HX HD SCREWGRADE 5, ZINC P	1.000 EA
HW1001A25	LOCKWASHER 1/4, ZINC PLT .493 OD, .255 I	1.000 EA
10XN3816K28	3/8-16 X 1.75 HEX HD CAP SCREW, GRADE 5	4.000 EA
HW1001A38	LOCKWASHER 3/8, ZINC PLT .688 OD, .382 I	4.000 EA
HW1001A38	LOCKWASHER 3/8, ZINC PLT .688 OD, .382 I	4.000 EA
HA4017A11	1/8 X 2.75 GREASE EXT (F/S)	1.000 EA
HA4017A03	.125 X 1.75 GREASE EXT (F/S)	1.000 EA
HW4019A01	PIPE COUPLING 1/8 NPT,STEEL,ZINC COATING	1.000 EA
HW4600B40	V-RING SLINGER 2.000 X 2.680 X .28 VITON	1.000 EA
HW5100A13	W4627-047 WVY WSHER	1.000 EA
HW4500A20	1/8NPT SL PIPE PLUG	1.000 EA
10XN3118K40	5/16-18 X 2.50" HEX HD, GRADE 5	4.000 EA
10EP1110A47P	PU ENDPLATE, MACH W/PRIMER	1.000 EA
10FH1007P	FAN COVER, CAST W/EPOXY PRIMER	1.000 EA
10XN3816K28	3/8-16 X 1.75 HEX HD CAP SCREW, GRADE 5	4.000 EA

Parts List (continued)		
Part Number	Description	Quantity
HW4500A20	1/8NPT SL PIPE PLUG	1.000 EA
HW4600B40	V-RING SLINGER 2.000 X 2.680 X .28 VITON	1.000 EA
10XN3118K40	5/16-18 X 2.50" HEX HD, GRADE 5	4.000 EA
10XN3118K20	5/16-18 X 1 1/4 GRADE 5 STEEL ZC PLATED	3.000 EA
HW1001A31	LOCKWASHER 5/16, ZINC PLT.591 OD, .319 I	3.000 EA
14GS1003	GASKET CONDUIT BOX LID, NEOP	1.000 EA
10XN2520K16	1/4-20 X 1" HX HD SCRW GRADE 5, ZINC P	4.000 EA
HW1001A25	LOCKWASHER 1/4, ZINC PLT .493 OD, .255 I	4.000 EA
HW2501H29	KEY, 1/2 SQ X 3.375	1.000 EA
MJ5001A27	32220KN GRAY SEALER *MIN BUY 4 QTS=1GAL	0.031 QT
MJ5001A14	DYNAPRO SEAL, CP MOTORS VC#2508050 (603	0.033 EA
MJ5002A01	SILICON RUBBER SEALANT, 732CL 10.3 OZ TU	0.025 EA
LB1115N	LABEL,LIFTING DEVICE (ON ROLLS)	1.000 EA
10EP1110A44GP6	FREP, MACH W/PRIMER & GREEN PAINT	1.000 EA
MN416A01	TAG-INSTAL-MAINT no wire (1200/bx) 11/14	1.000 EA
LB1002N	LABEL,MARINE DUTY (ON ROLLS)	1.000 EA
HA4051A00	PLASTIC CAP FOR GREASE FITTING	1.000 EA
HW4500A21	1618BALEMITE FITTING 825 UNIVERSAL	1.000 EA
HW4500A17	317400 ALEMITE GREASE RELIEF	1.000 EA
HA4054	SHORT T-DRAIN FITTING, .125" N.P.T.	1.000 EA
MJ1000A02	GREASE, POLYREX EM EXXON (USe 4824-15A)	0.130 LB
HA4051A00	PLASTIC CAP FOR GREASE FITTING	1.000 EA
HW4500A17	317400 ALEMITE GREASE RELIEF	1.000 EA
HW4500A03	GREASE FITTING, .125 NPT 1610(ALEMITE) 8	1.000 EA

Product Information Packet: ECP2402T-4 - 10HP,880RPM,3PH,60HZ,284T,1060M,TEFC,F1

HA4054	SHORT T-DRAIN FITTING, .125" N.P.T.	1.000 EA
HW2500A25	WOODRUFF KEY USA #1008 #BLOW CARBON STEE	1.000 EA
51XB1214A20	12-14X1.25 HXWSSLD SERTYB	1.000 EA
MG1025N19	WILKOFAS, 778.50, RELIANCE BLUE-GREEN	0.070 GA
85XU0407S04	4X1/4 U DRIVE PIN STAINLESS	4.000 EA
LB1119N	WARNING LABEL	1.000 EA
LC0006	CONNECTION LABEL	1.000 EA
NP3241	SS SUPER-E INV UL CSA-EEV PREM CC	1.000 EA
10PA1000	PACKAGING GROUP COMBINED PRINT PK1023A06	1.000 EA
LB1449	DIV-2/NEC WARNING LABEL	1.000 EA

AC Induction Motor Performance Data

Record # 47240 - Typical performance - not guaranteed values

Winding: 10WGY680-R011	Type: 1060M	Enclosure: TEFC
-------------------------------	--------------------	------------------------

Nameplate Data				460 V, 60 Hz: Single Voltage Motor	
Rated Output (HP)	10			Full Load Torque	59.6 LB-FT
Volts	460			Start Configuration	direct on line
Full Load Amps	14.4			Breakdown Torque	128 LB-FT
R.P.M.	880			Pull-up Torque	100 LB-FT
Hz	60	Phase	3	Locked-rotor Torque	144 LB-FT
NEMA Design Code	B	KVA Code	G	Starting Current	71.5 A
Service Factor (S.F.)	1.15			No-load Current	7.76 A
NEMA Nom. Eff.	90.2	Power Factor	72	Line-line Res. @ 25°C	1.02 Ω
Rating - Duty	40C AMB-CONT			Temp. Rise @ Rated Load	38°C
S.F. Amps				Temp. Rise @ S.F. Load	47°C
				Rotor inertia	7.39 LB-FT ²

Load Characteristics 460 V, 60 Hz, 10 HP

% of Rated Load	25	50	75	100	125	150	S.F.
Power Factor	34	53	66	72	74	74	73
Efficiency	84.9	90	90.9	90.6	90	88.2	90.2
Speed	895	891	886	880	874	866	876
Line amperes	8.31	9.84	11.8	14.4	17.4	21.2	16.2

Performance Graph at 460V, 60Hz, 10.0HP Typical performance - Not guaranteed values

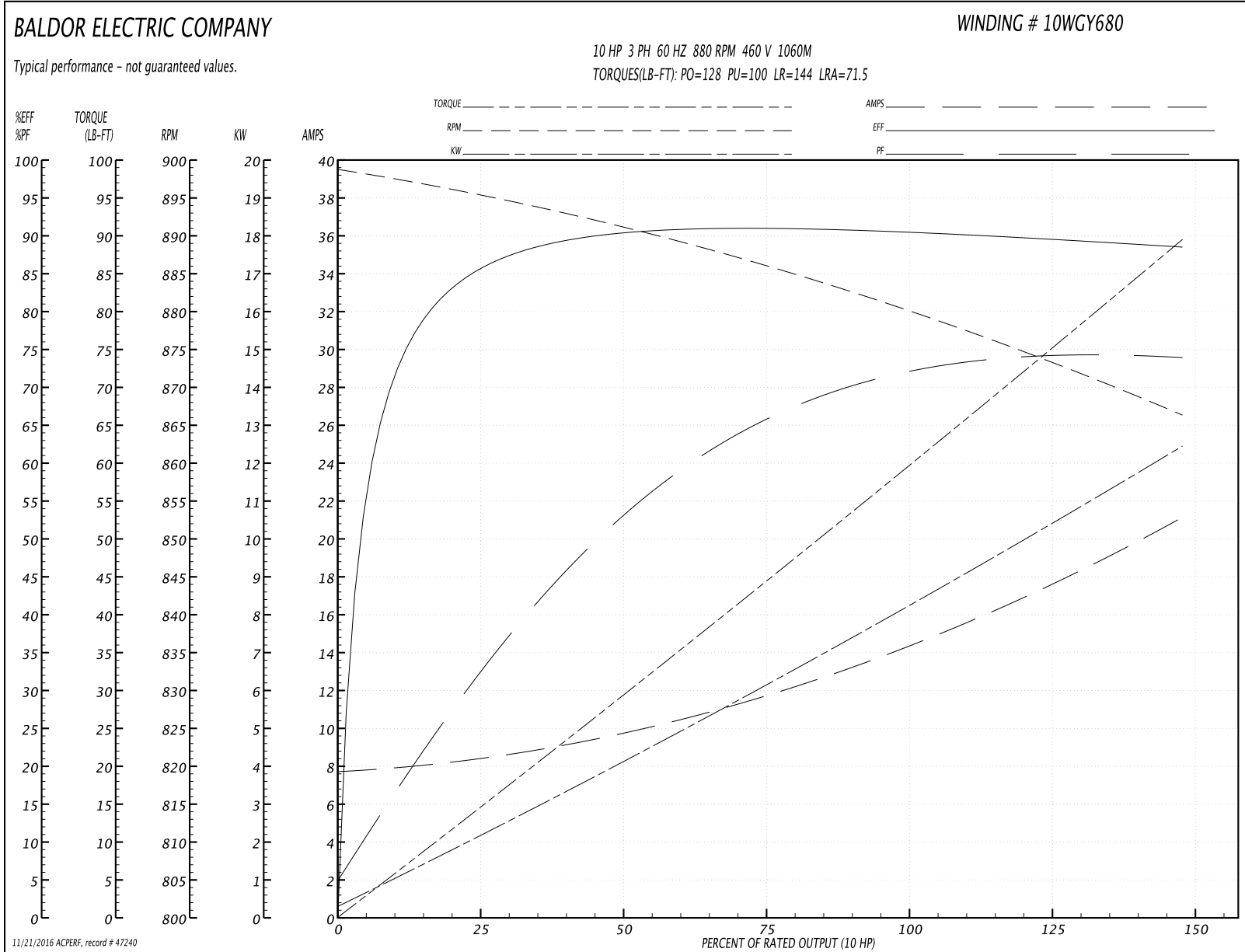

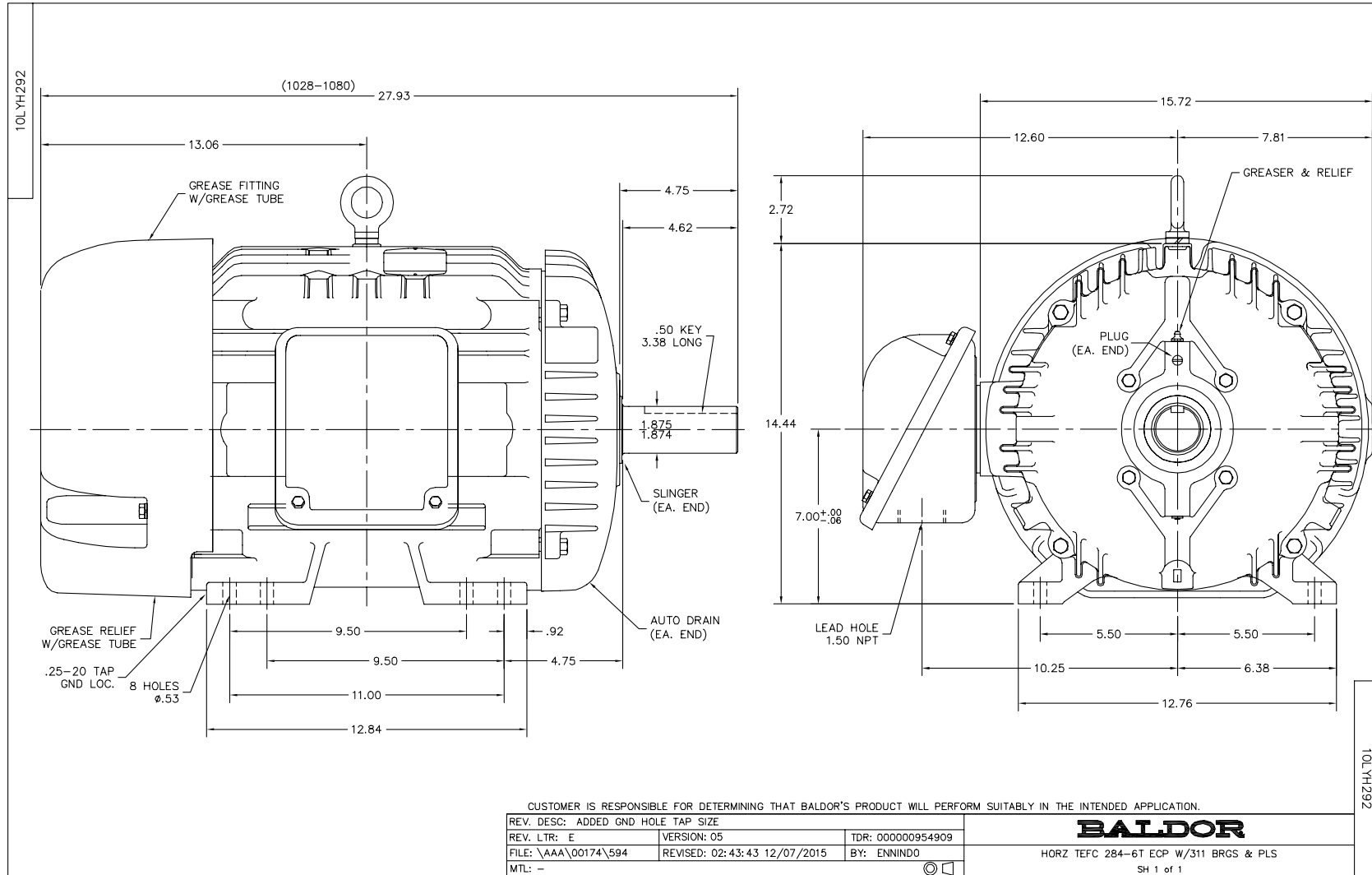

CD0006



NOTES:

1. THREE LEAD MOTOR MAY BE EITHER WYE CONNECTED OR DELTA CONNECTED.
2. INTERCHANGE ANY TWO LINE LEADS TO REVERSE ROTATION.
3. OPTIONAL THERMOSTATS ARE PROVIDED WHEN SPECIFIED.
4. ACTUAL NUMBER OF INTERNAL PARALLEL CIRCUITS MAY VARY.
5. LEAD COLORS ARE OPTIONAL. LEADS MUST BE NUMBERED AS SHOWN.

REV. DESC: REVISE TO SHOW OPTIONAL COLORS			
REV. LTR: D	BY: JLP	REVISED: 01/21/99 4:02	TDR: 0171435
9000D		FILE: AAA00005141	MDL: -
		MTL: -	

BALDOR ELECTRIC Co.

3PH, SV, 3 LEADS, WYE OR DELTA CONNECTED

CD0006