

BALDOR® • *RELIANCE*

Product Information Packet

JMEWDM23933T

15HP, 1765RPM, 3PH, 60HZ, 254JM, 3942M, TEFC, F

Part Detail							
Revision:	C	Status:	PRD/A	Change #:		Proprietary:	No
Type:	AC	Prod. Type:	3942M	Elec. Spec:	39WGW595	CD Diagram:	CD0005
Enclosure:	TEFC	Mfg Plant:		Mech. Spec:	39K68	Layout:	39LYK068
Frame:	254JM	Mounting:	F1	Poles:	04	Created Date:	12-05-2014
Base:	RG	Rotation:	R	Insulation:	F	Eff. Date:	06-06-2016
Leads:	9#12					Replaced By:	
Literature:		Elec. Diagram:					

Nameplate NP1669L										
CAT.NO.	JMEWDM23933T									
SPEC.	39K068W595G1									
HP	15									
VOLTS	230/460									
AMP	36/18									
RPM	1765									
FRAME	254JM				HZ	60			PH	3
SER.F.	1.15		CODE	H	DES	A		CLASS	F	
NEMA-NOM-EFF	92.4		PF	84						
RATING	40C AMB-CONT									
CC	010A				USABLE AT 208V			36		
DE	6309			ODE	6208					
ENCL	TEFC		SN							
BLANK										

Parts List		
Part Number	Description	Quantity
SA290804	SA 39K068W595G1	1.000 EA
RA276959	RA 39K068W595G1	1.000 EA
S/P107-000-005	SUPER-E PROC'S(254/6 FR.) ZK PLANT - POL	1.000 EA
HA6016P	ADAPTER, CAST CONDUIT BOX EPOXY PRIMER	1.000 EA
09GS1006	GASKET, CONDUIT BOX, NEOP-1/16 THICK-BLA	1.000 EA
09CB3000A02P	SPL 309 CONDUIT BOX W/1.25 N.P.T. W/PRI	1.000 EA
RM1017	LEAD SEPERATOR GASKET MODEL 307 1/8" THK	1.000 EA
51XW2520A12	.25-20 X .75, TAPTITE II, HEX WSHR SLTD	2.000 EA
HW1001A25	LOCKWASHER 1/4, ZINC PLT .493 OD, .255 I	2.000 EA
WD1000B17	T&B CX35TN TERMINAL	1.000 EA
11XW1032G06	10-32 X .38, TAPTITE II, HEX WSHR SLTD U	1.000 EA
39EP1100A08WP	FR ENDPLATE, MACH W/WHITE EPOXY, PRIMED	1.000 EA
HW4600B44	V-RING SLINGER 1.500 X 1.810 X .28 VITON	1.000 EA
HW5100A08	W3118-035 WVY WSHR (WB)	1.000 EA
10XN2520S28	1/4-20X 1 3/4 HEX HD SS X	4.000 EA
39EP1500A06P	PU ENDPLATE, MACH W/EPOXY PRIMER	1.000 EA
HW4600A27	SEAL 1.750 X 2.441 X 0.313 SINGLE LIP	1.000 EA
HW4600B67	V-RING SLINGER 1.770 X 2.170 X .28 VITON	1.000 EA
HA3154S02	THRUBOLT STUD 3/8-16 X 15.875 SS	4.000 EA
XY3816S12	3/8-16 HEX FINISHED NUT SS	8.000 EA
HA2001B08	SPL SPACER FOR AIR DEFLECTOR .50 O.D. X	3.000 EA
10XN2520S16	41/4-20 X 1 HEX HEAD SS	3.000 EA
09CB3500P	CONDUIT BOX LID, CAST W/PRIMER	1.000 EA
09GS1001A01	GASKET, BOX LID, 1/8 THICK BLACK NEOPREN	1.000 EA

Parts List (continued)		
Part Number	Description	Quantity
19XT2520S12	1/4-20X3/4 HWH NO SLOT TY.23 18-8 S.S.	2.000 EA
HW1001S25	WASHER, 1/4 SPLT LK, STAINLESS STEEL	2.000 EA
HW2502E18	#303 SS,SQ KEY 1/4 X 2.000	1.000 EA
MJ5001A27	32220KN GRAY SEALER *MIN BUY 4 QTS=1GAL	0.016 QT
MJ5002A01	SILICON RUBBER SEALANT, 732CL 10.3 OZ TU	0.025 EA
LB1115N	LABEL,LIFTING DEVICE (ON ROLLS)	1.000 EA
LB1164	LABEL,WARNING AND DRAIN	1.000 EA
HW4032A01	BLACK DRAIN PLUG FOR WASH DOWN MOTORS	3.000 EA
MJ1000A02	GREASE, POLYREX EM EXXON (USe 4824-15A)	0.085 LB
HW4032A01	BLACK DRAIN PLUG FOR WASH DOWN MOTORS	3.000 EA
09FN3001D01	EXTERNAL FAN, PLASTIC	1.000 EA
HW2500A25	WOODRUFF KEY USA #1008 #BLOW CARBON STEE	1.000 EA
51XB1214A20	12-14X1.25 HXWSSLD SERTYB	1.000 EA
09FH4000A23MWP	FAN COVER, MACH W/WHITE EPOXY	1.000 EA
MG1025W01	WILKOFAS, 781.01, SIGNAL WHITE #9003	0.050 GA
85XU0407S04	4X1/4 U DRIVE PIN STAINLESS	2.000 EA
LB1119N	WARNING LABEL	1.000 EA
LC0005	CONN.DIA.,TY M,9-LD,DUAL VOLT,REVERSING	1.000 EA
NP1669L	SS WD SUPER-E UL CSA-EEV PREM REV MTG	1.000 EA
39PA1000	PACKAGING GROUP 39 PRINT	1.000 EA
MN416A01	TAG-INSTAL-MAINT no wire (1200/bx) 11/14	1.000 EA

No performance data has been
assigned to this product.

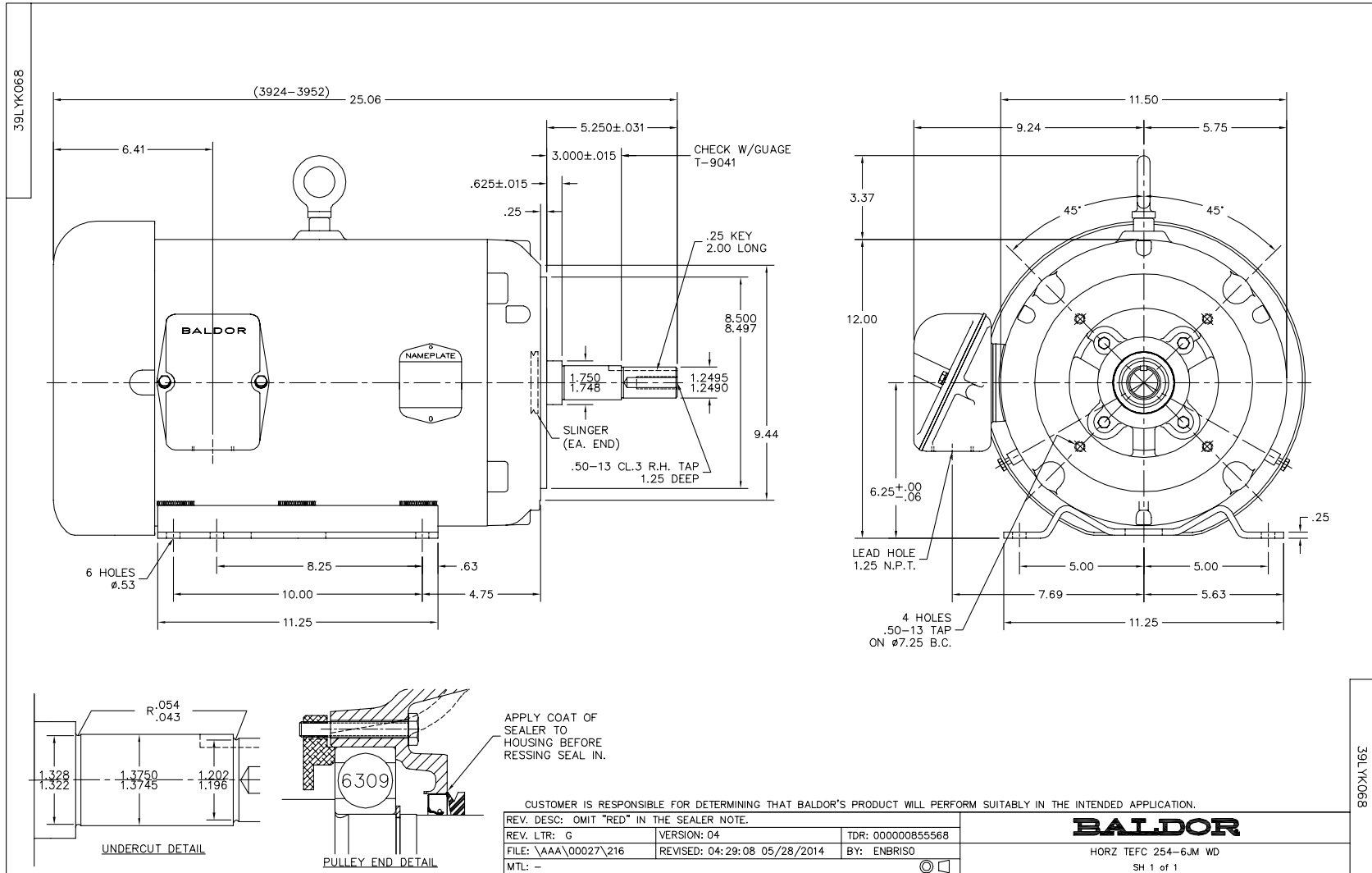

CD0005



LOW VOLTAGE
(2Y)

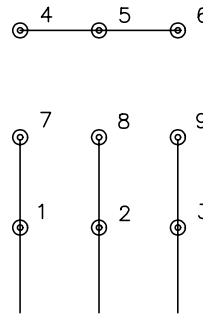

LINE

HIGH VOLTAGE
(1Y)



LINE

NOTES:

1. INTERCHANGE ANY TWO LINE LEADS TO REVERSE ROTATION.
2. OPTIONAL THERMOSTATS ARE PROVIDED WHEN SPECIFIED.
3. ACTUAL NUMBER OF INTERNAL PARALLEL CIRCUITS MAY BE A MULTIPLE OF THOSE SHOWN ABOVE.
4. LEAD COLORS ARE OPTIONAL. LEADS MUST ALWAYS BE NUMBERED AS SHOWN.

REV. DESC: REVISE TO SHOW OPTIONAL COLORS			
REV. LTR: E	BY: JLP	REVISED: 01/19/99 10:15	TDR: 0171435
900000		FILE: AAA00005140	MDL: -
		MTL: -	

BALDOR ELECTRIC Co.

3PH, DV, 9 LEADS

CD0005