

EOM

**ENGINEERING OPERATION
& MAINTENANCE MANUAL**

**GPS420/GPS430, GPS820/830
and GPS1520/GPS1530**

CSA-Certified Metal Pumps

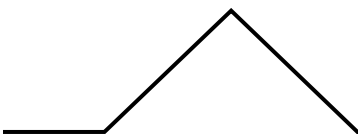
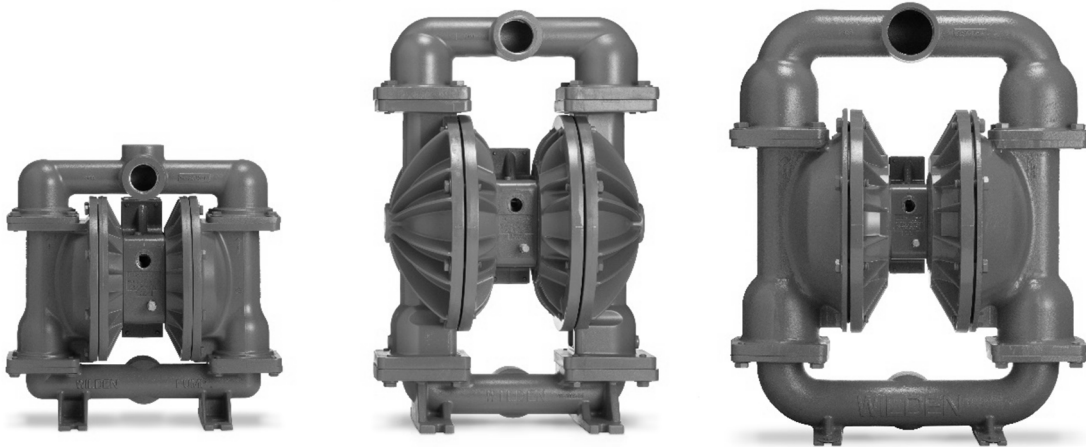

Where Innovation Flows

WILDEN®



Copyright

Copyright 2018 PSG®, a Dover Company. All rights reserved.

PSG reserves the right to modify the information and illustrations in this document without prior notice. The product described in this document is furnished under a license agreement or nondisclosure agreement. No part of this document may be reproduced, stored in a retrieval system, or transmitted in any form or any means electronic or mechanical, including photocopying and recording, without the written permission of PSG, a Dover Company, except as described by the terms of those agreements.

This is a non-contractual document.

Trademarks

PSG and the PSG logo are registered trademarks of PSG. Wilden® is a registered trademark of PSG California LLC. Pro-Flo® SHIFT and Pro-Flo® are registered trademarks of PSG California LLC. Wil-Flex® is a trademark of PSG California LLC. Saniflex™ is a trademark of PSG California LLC.

All trademarks, names, logos and service marks (collectively “trademarks”) in this document are registered and unregistered trademarks of their respective owners. Nothing contained in this document should be construed as granting any license or right to use any trademark without the prior written permission of the trademark owner.

Warranty

Each and every product manufactured by Wilden is built to meet the highest standards of quality. Every pump is functionally tested to ensure integrity of operation. Wilden warrants that pumps, accessories and parts manufactured or supplied by it to be free from defects in material and workmanship for a period of five (5) years from date of installation or six (6) years from date of manufacture, whichever comes first.

For more information, and to register your Wilden pump for warranty, please visit <https://www.psgdover.com/wilden/support/warranty-registration>.

Certifications





CONTENTS

SECTION 1: Precautions – Read First!	4
SECTION 2: Wilden Pump Designation System	5
SECTION 3: How It Works	6
SECTION 4: Dimensional Drawings	7
SECTION 5: Performance	12
GPS420/GPS430 Metal EZ-Install TPE-Fitted.....	12
GPS420/GPS430 Metal Full-Stroke PTFE-Fitted	12
GPS820/GPS830 Metal EZ-Install TPE-Fitted.....	13
GPS820/GPS830 Metal Full-Stroke PTFE-Fitted	13
GPS1520/GPS1530 Metal EZ-Install TPE-Fitted.....	14
GPS1520/GPS1530 Metal Full-Stroke PTFE-Fitted	14
Suction Lift Capability.....	15
SECTION 6: Suggested Installation, Operation, Maintenance, and Troubleshooting	17
SECTION 7: Disassembly/Reassembly	20
Pump Disassembly.....	20
Grounding Strap for CSA Pumps	22
Air Valve/Center Section Disassembly	23
Single-Point Exhaust.....	26
Reassembly Hints and Tips	26
SECTION 8: Exploded View and Parts List	28

SECTION 1

PRECAUTIONS – READ FIRST!

 **WARNING:** Always wear safety glasses when operating a pump to avoid eye injury. If diaphragm rupture occurs, material being pumped may be forced out of the air exhaust.

 **CAUTION:** Do not apply pressurized gas to the exhaust port – pump will not function.

 **CAUTION:** Do not over-lubricate air supply– excess lubrication will reduce pump performance. Pump is pre-lubed.

 **TEMPERATURE LIMITS:**

Buna-N	-12°C to 82°C	10°F to 180°F
PTFE*	4°C to 104°C	40°F to 220°F
Wil-Flex	-40°C to 107°C	-40°F to 225°F

*4°C to 149°C (40°F to 300°F) - 13 mm (1/2") and 25 mm (1") models only.

 **CAUTION:** Canadian Standards Association (CSA) configured pumps should not be used in temperatures lower than 0°C (32°F) or higher than 52°C (125°F).

 **CAUTION:** Maximum temperature limits are based on mechanical stress only. Certain chemicals will reduce maximum safe operating temperatures significantly. Consult the Chemical Resistance Guide for chemical compatibility and temperature limits.

 **WARNING:** Prevent static sparking – if static sparking occurs, fire or explosion could result. Pump, valves and containers must be grounded to a proper grounding point when handling flammable fluids and whenever discharge of static electricity is a hazard. Pumps must be electrically grounded using the grounding conductor provided. Improper grounding can cause improper and dangerous operation.

 **CAUTION:** Do not exceed 8.6 bar (125 psig) air supply pressure.

 **CAUTION:** Do not exceed 82°C (180°F) air inlet temperature for all models.

 **CAUTION:** The process fluid and cleaning fluids must be compatible chemically with all wetted pump components. Consult chemical resistance guide.

 **CAUTION:** Before attempting any maintenance or repair, disconnect the compressed air line to the pump and allow all air pressure to bleed from the pump. Disconnect all intake, discharge, and air lines. Drain the pump by turning it upside down and allowing any fluid to flow into a suitable container. Be aware of any hazardous effects of contact with your process fluid.

 **CAUTION:** Thoroughly flush pumps before installing them into process lines.

 **CAUTION:** Ensure that the gas supply line is clear of debris. Use an in-line air filter. A 5µ (micron) air filter is recommended.

 **CAUTION:** Before installation, tighten all hardware.

 **CAUTION:** All CSA-Certified pumps are fitted with a single-point exhaust to route all exhaust gas through the muffler exhaust port. The gas outlet must be vented to a safe location in accordance with local codes or, in the absence of local codes, an industry or nationally recognized code having jurisdiction over the specified installation.

 **NOTE:** Materials of construction and elastomer material may influence suction lift parameters. Please refer to "Performance" for specifics.

 **NOTE:** When installing PTFE diaphragms, it is important to tighten outer pistons simultaneously (turning in opposite directions) to ensure tight fit. (See "Maximum Torque Specifications").

 **NOTE:** Some PTFE-fitted pumps come standard from the factory with expanded PTFE gaskets installed in the diaphragm bead of the liquid chamber. PTFE gaskets cannot be re-used.

 **NOTE:** In the event of a power failure, close the shut-off valve if you do not want the pump to restart when the power returns.

 **NOTE:** The Safety Supplement document is a part of the manual. Please refer to the Safety Supplement document for a complete list of safety considerations including considerations for safe operation and maintenance of pumps marked for ATEX environments before starting the pump.

 **WARNING:** This product can expose you to chemicals including Nickel, Chromium, Cadmium, or Cobalt, which are known to the State of California to cause cancer and/or birth defects or other reproductive harm. For more information, go to www.P65Warnings.ca.gov.

SECTION 3

HOW IT WORKS – AIR-OPERATED DOUBLE-DIAPHRAGM PUMP

The Wilden diaphragm pump is an air-operated, positive displacement, self-priming pump. These drawings show flow pattern through the pump upon its initial stroke. It is assumed the pump has no fluid in it prior to its initial stroke.

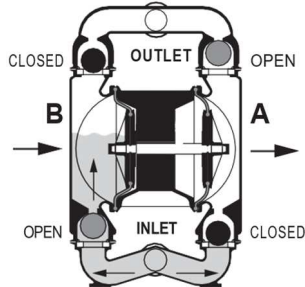

FIGURE 1 The air valve directs pressurized air to the back side of diaphragm A. The compressed air is applied directly to the liquid column separated by elastomeric diaphragms. The diaphragm acts as a separation membrane between the compressed air and liquid; a balanced load removes mechanical stress from the diaphragm. The compressed air moves the diaphragm away from the center of the pump. The opposite diaphragm is pulled in by the shaft connected to the pressurized diaphragm. Diaphragm B is on its suction stroke; air behind the diaphragm has been forced out to atmosphere through the exhaust port of the pump. The movement of diaphragm B toward the center of the pump creates a vacuum within chamber B. Atmospheric pressure forces fluid into the inlet manifold forcing the inlet valve ball off its seat. Liquid is free to move past the inlet valve ball and fill the liquid chamber (see shaded area).

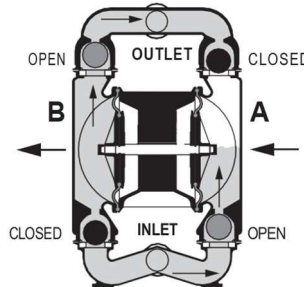

FIGURE 2 When the pressurized diaphragm, diaphragm A, reaches the limit of its discharge stroke, the air valve redirects pressurized air to the back side of diaphragm B. The pressurized air forces diaphragm B away from the center while pulling diaphragm A to the center. Diaphragm B is now on its discharge stroke. Diaphragm B forces the inlet valve ball onto its seat due to the hydraulic forces developed in the liquid chamber and manifold of the pump. These same hydraulic forces lift the discharge valve ball off its seat, while the opposite discharge valve ball is forced onto its seat, forcing fluid to flow through the pump discharge. The movement of diaphragm A toward the center of the pump creates a vacuum within liquid chamber A. Atmospheric pressure forces fluid into the inlet manifold of the pump. The inlet valve ball is forced off its seat allowing the fluid being pumped to fill the liquid chamber.

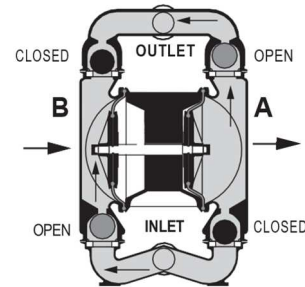
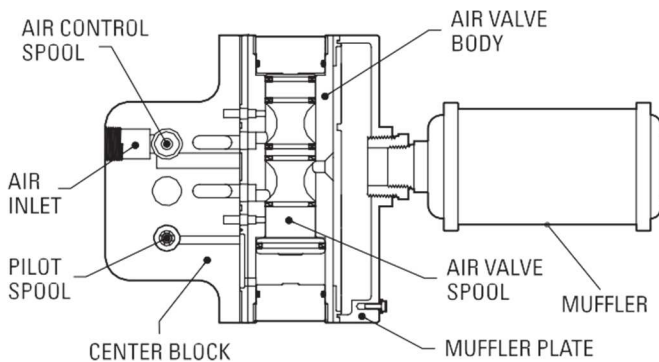

FIGURE 3 At completion of the stroke, the air valve again redirects air to the back side of diaphragm A, which starts diaphragm B on its exhaust stroke. As the pump reaches its original starting point, each diaphragm has gone through one exhaust and one discharge stroke. This constitutes one complete pumping cycle. The pump may take several cycles to completely prime depending on the conditions of the application.

HOW IT WORKS – AIR DISTRIBUTION SYSTEM



The heart of the patented Pro-Flo® SHIFT Air Distribution System (ADS) is the air valve assembly. The air valve design incorporates an unbalanced spool with the small end of the spool being pressurized continuously while the large end of the spool is alternately pressurized, then exhausted to move the spool. The air valve spool directs pressurized air to one chamber while exhausting the other. The air forces the main shaft/diaphragm assembly to move to one side – discharging liquid on that side and pulling liquid in on the other side. When the shaft reaches the end of the stroke, the inner piston actuates the pilot spool, which controls the air to the large end of the air valve spool. The repositioning of the air valve spool routes the air to the other air chamber. The air control spool allows air to flow freely into the air chamber for the majority of each pump stroke, but it significantly restricts the flow of air into the air chamber when activated by the inner piston near the end of each stroke.

SECTION 4

DIMENSIONAL DRAWING

GPS420 METAL

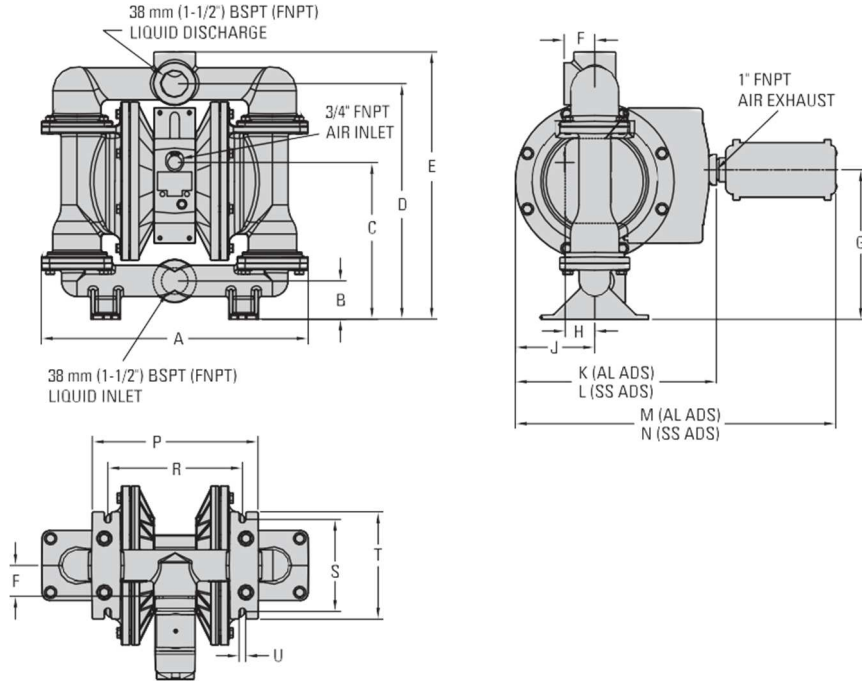

DIMENSIONS

ITEM	METRIC (mm)	STANDARD (inch)
A	442	17.4
B	64	2.5
C	261	10.3
D	391	15.4
E	445	17.5
F	51	2.0
G	249	9.8
H	49	1.9
J	132	5.2
K	333	13.1
L	326	12.9
M	531	20.9
N	525	20.7
P	274	10.8
R	224	8.8
S	152	6.0
T	178	7.0
U	11	0.4

LW0231 REV. E

GPS430 ALUMINUM

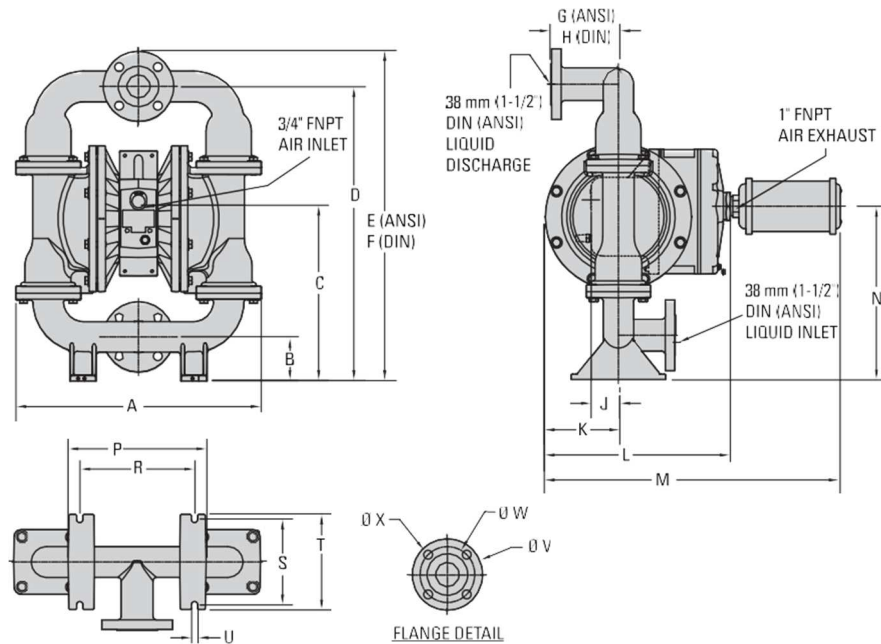

DIMENSIONS

ITEM	METRIC (mm)	STANDARD (inch)
A	442	17.4
B	80	3.1
C	324	12.7
D	531	20.9
E	594	23.4
F	606	23.9
G	122	4.8
H	122	4.8
J	50	2.0
K	132	5.2
L	334	13.1
M	531	20.9
N	312	12.3
P	274	9.7
R	206	8.1
S	152	6.0
T	170	6.7
U	11	0.4
	DIN (mm)	ANSI (Inch)
V	150 DIA.	5.0 DIA.
W	109 DIA.	4.3 DIA.
X	16 DIA.	0.6 DIA.

LW0296 REV. B

DIMENSIONAL DRAWING

GPS430 STAINLESS STEEL

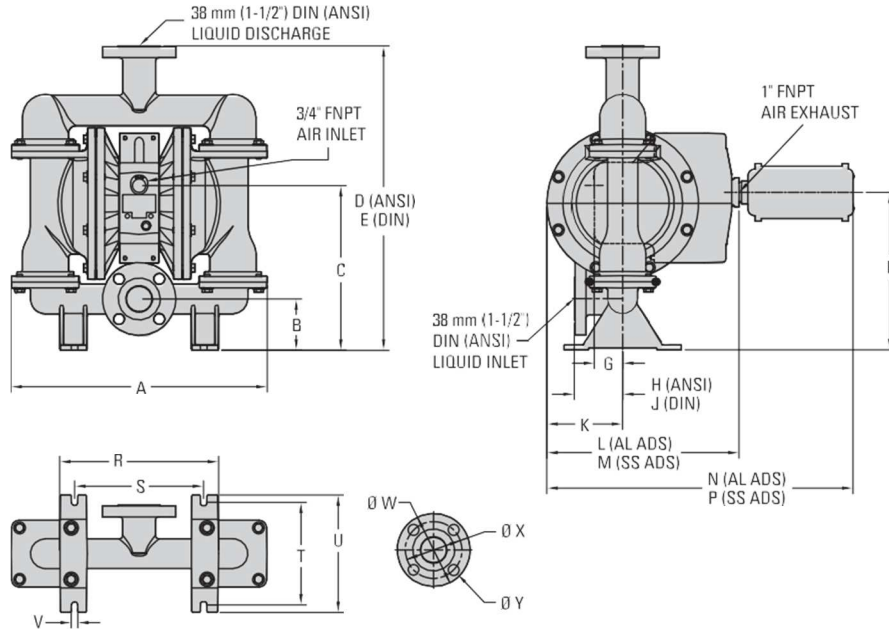

DIMENSIONS

ITEM	METRIC (mm)	STANDARD (inch)
A	443	17.5
B	89	3.5
C	285	11.2
D	528	20.8
E	529	20.8
F	273	10.8
G	49	1.9
H	84	3.3
J	86	3.4
K	132	5.2
L	333	13.1
M	326	12.9
N	531	20.9
P	525	20.7
R	274	10.8
S	224	8.8
T	178	7.0
U	203	8.0
V	11	0.4
	DIN (mm)	ANSI (Inch)
W	150 DIA.	5.0 DIA.
X	109 DIA.	4.3 DIA.
Y	16 DIA.	0.6 DIA.

LW0233 REV. D

GPS820 ALUMINUM

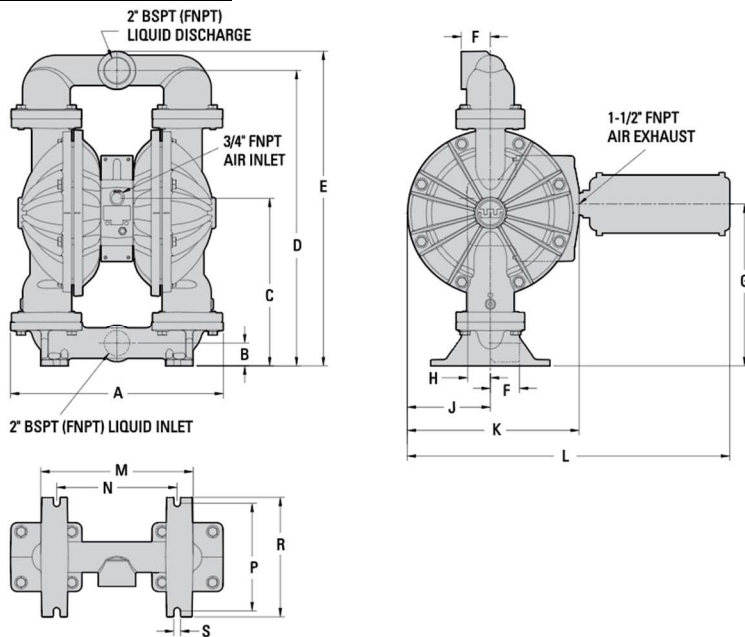

DIMENSIONS

ITEM	METRIC (mm)	STANDARD (inch)
A	453	17.9
B	48	1.9
C	358	14.1
D	630	24.8
E	670	26.4
F	62	2.4
G	346	13.6
H	48	1.9
J	177	7.0
K	366	14.4
L	687	27.1
M	324	12.8
N	257	10.1
P	229	9.0
R	254	10.0
S	14	0.6

LW0238 REV. C

DIMENSIONAL DRAWING

GPS820 STAINLESS STEEL

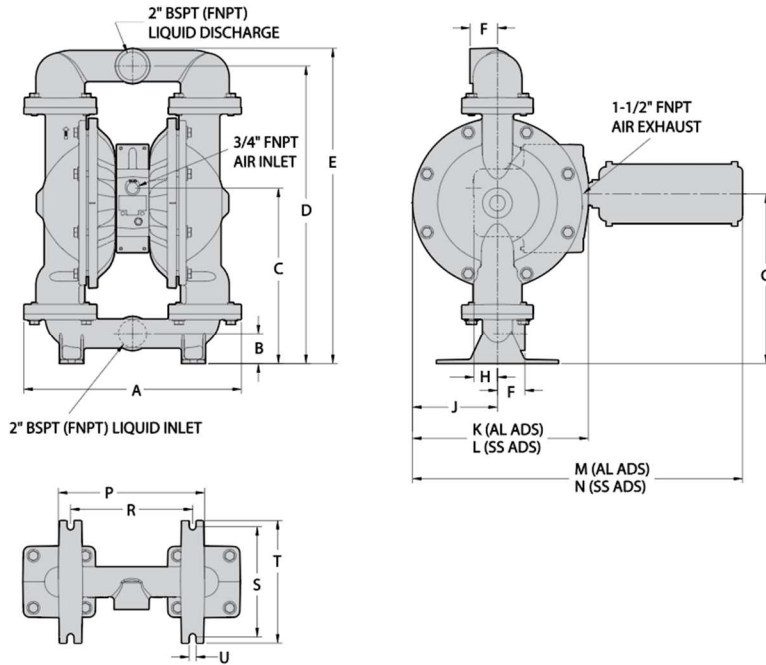

DIMENSIONS

ITEM	METRIC (mm)	STANDARD (inch)
A	452	17.8
B	64	2.5
C	367	14.3
D	620	24.4
E	658	25.9
F	58	2.3
G	354	14.0
H	48	1.9
J	178	7.0
K	366	14.4
L	359	14.2
M	687	27.0
N	679	26.8
P	305	12.0
R	254	10.0
S	229	9.0

LW0240 REV. B

GPS830 ALUMINUM

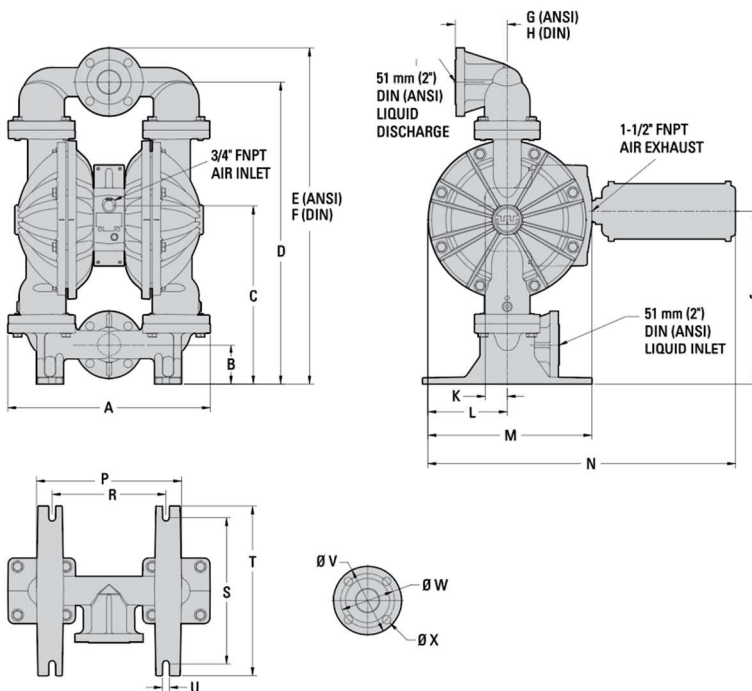

DIMENSIONS

ITEM	METRIC (mm)	STANDARD (inch)
A	452	17.8
B	89	3.5
C	400	15.7
D	675	26.6
E	752	29.6
F	758	29.8
G	116	4.6
H	117	4.6
J	387	15.3
K	48	1.9
L	177	7.0
M	366	14.4
N	687	27.1
P	324	12.8
R	254	10.0
S	326	12.8
T	378	14.9
U	16	0.6
	DIN (mm)	ANSI (Inch)
V	165 DIA.	6.0 DIA.
W	125 DIA.	4.8 DIA.
X	18 DIA.	0.8 DIA.

LW0239 REV. C

DIMENSIONAL DRAWING

GPS830 STAINLESS STEEL

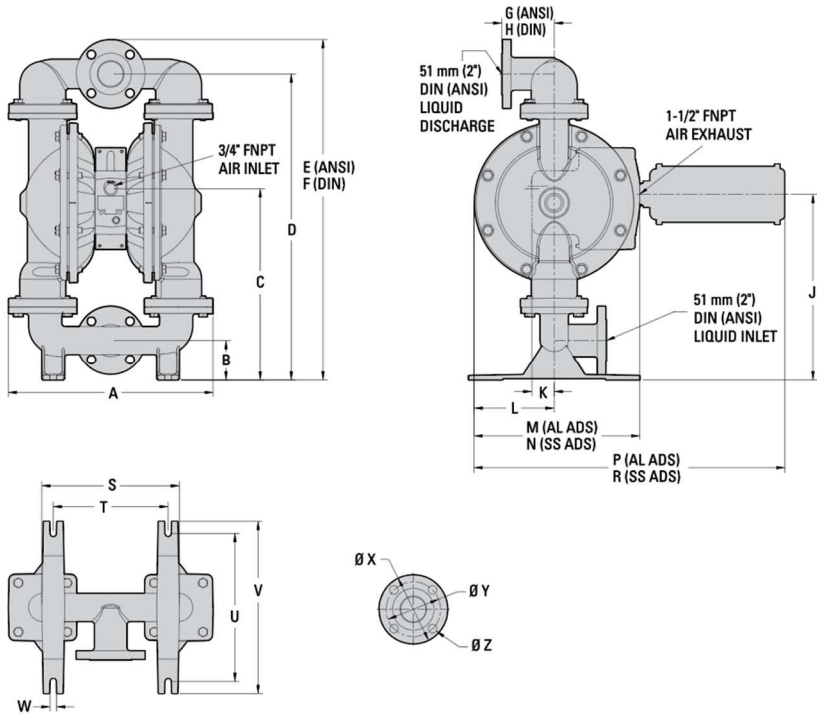

DIMENSIONS

ITEM	METRIC (mm)	STANDARD (inch)
A	452	17.8
B	89	3.5
C	424	16.7
D	678	26.7
E	754	29.7
F	760	29.9
G	116	4.6
H	115	4.5
J	412	16.2
K	48	1.9
L	177	7.0
M	361	14.2
N	361	14.2
P	677	27.1
R	682	26.9
S	304	12.0
T	254	10.0
U	325	12.8
	DIN (mm)	ANSI (Inch)
X	165 DIA.	6.0 DIA.
Y	125 DIA.	4.8 DIA.
Z	18 DIA.	0.8 DIA.

LW0241 REV. B

GPS1520 ALUMINUM

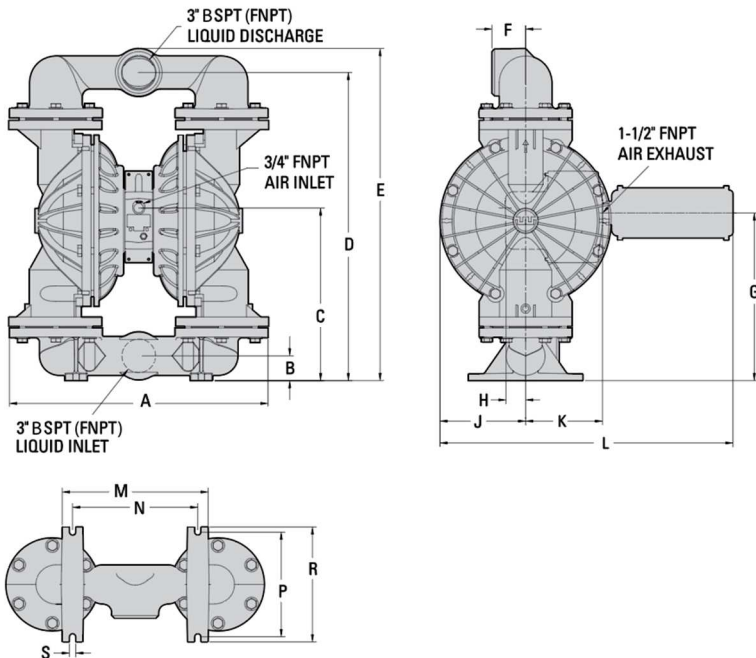

DIMENSIONS

ITEM	METRIC (mm)	STANDARD (inch)
A	635	25.0
B	61	2.4
C	426	16.8
D	759	29.9
E	818	32.2
F	84	3.3
G	414	16.3
H	48	1.9
J	211	8.3
K	189	7.4
L	720	28.4
M	358	14.1
N	307	12.1
P	257	10.1
R	282	11.1
S	15	0.6

LW0258 REV. C

DIMENSIONAL DRAWING

GPS1520 STAINLESS STEEL

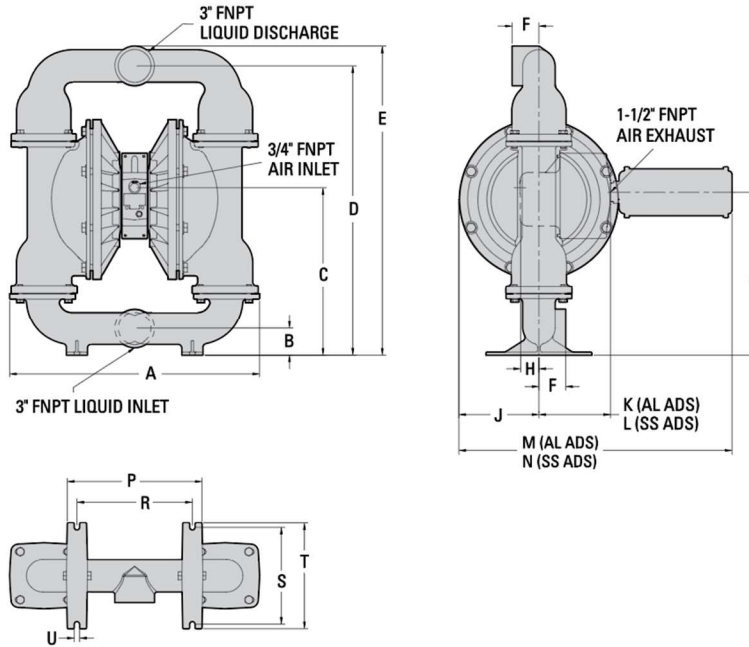

DIMENSIONS

ITEM	METRIC (mm)	STANDARD (inch)
A	650	25.6
B	71	2.8
C	443	17.5
D	765	30.1
E	815	32.1
F	71	2.8
G	431	17.0
H	48	1.9
J	211	8.3
K	189	7.4
L	184	7.3
M	721	28.4
N	715	28.2
P	356	14.0
R	305	12.0
S	257	10.1
T	279	11.0
U	15	0.6

LW0259 REV. C

GPS1530 STAINLESS STEEL

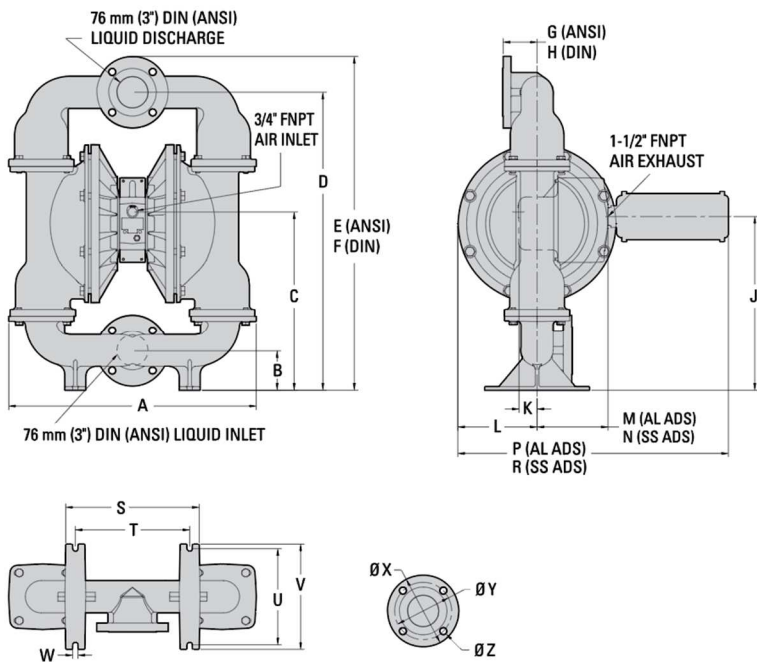

DIMENSIONS

ITEM	METRIC (mm)	STANDARD (inch)
A	673	26.5
B	105	4.1
C	477	18.8
D	796	31.3
E	890	35.1
F	891	35.3
G	90	3.6
H	88	3.5
J	465	18.3
K	48	1.9
L	211	8.3
M	189	7.4
N	184	7.3
P	721	28.4
R	715	28.2
S	356	14.0
T	305	12.0
U	256	10.1
	DIN (mm)	ANSI (inch)
X	200 DIA.	7.5 DIA.
Y	160 DIA.	6.0 DIA.
Z	18 DIA.	0.8 DIA.

LW0260 REV. C

SECTION 5

PERFORMANCE

**GPS420/GPS430 METAL
EZ-INSTALL TPE-FITTED**

Ship Weights...420 Threaded AL 26 kg (57 lb)
420 Threaded SS 50 kg (111 lb)
430 Flanged AL 28 kg (62 lb)
430 Flanged SS 53 kg (116 lb)

Air Inlet.....3/4"
Inlet.....38 mm (1-1/2")
Outlet.....38 mm (1-1/2")
Suction Lift.....4.7 m Dry (15.3')
9.0 m Wet (29.5')

Disp. per Stroke¹.....0.8 L (0.22 gal)
Max. Flow Rate.....441 lpm (117 gpm)
Max. Size Solids.....6.4 mm (1/4")

¹Displacement per stroke was calculated at 4.8 bar (70 psig) air inlet pressure against a 2.1 bar (30 psig) head pressure.

Example: To pump 242 lpm (64 gpm) against a discharge head of 2.1 bar (30 psig) requires 4.1 bar (60 psig) and 63 Nm³/h (37 scfm) air consumption.

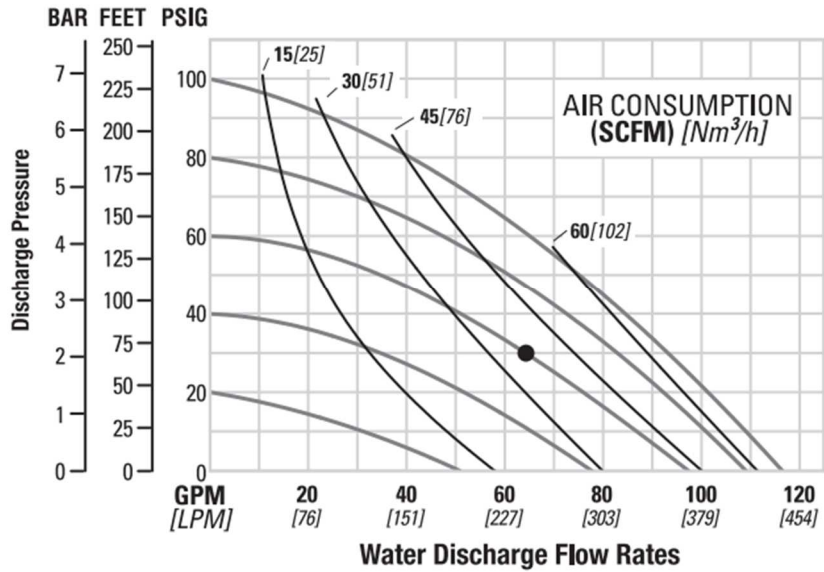

Flow rates indicated on chart were determined by pumping water. For optimum life and performance, pumps should be specified so that daily operation parameters will fall in the center of the pump's performance curve.

Caution: Do not exceed 6.9 bar (100 psig) air supply pressure.

**GPS420/GPS430 METAL
FULL-STROKE
PTFE-FITTED**

Ship Weights...420 Threaded AL 26 kg (57 lb)
420 Threaded SS 50 kg (111 lb)
430 Flanged AL 28 kg (62 lb)
430 Flanged SS 53 kg (116 lb)

Air Inlet.....3/4"
Inlet.....38 mm (1-1/2")
Outlet.....38 mm (1-1/2")
Suction Lift.....4.5 m Dry (14.8')
8.6 m Wet (28.4')

Disp. per Stroke¹.....0.9 L (0.24 gal)
Max. Flow Rate.....460 lpm (122 gpm)
Max. Size Solids.....6.4 mm (1/4")

¹Displacement per stroke was calculated at 4.8 bar (70 psig) air inlet pressure against a 2.1 bar (30 psig) head pressure.

Example: To pump 280 lpm (74 gpm) against a discharge head of 2.1 bar (30 psig) requires 5.5 bar (80 psig) and 88 Nm³/h (52 scfm) air consumption.

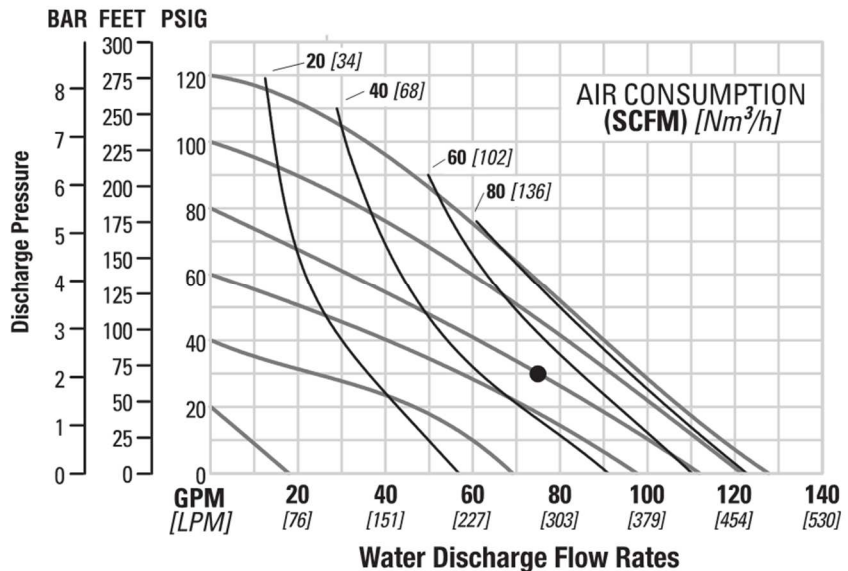

Flow rates indicated on chart were determined by pumping water. For optimum life and performance, pumps should be specified so that daily operation parameters will fall in the center of the pump's performance curve.

Caution: Do not exceed 6.9 bar (100 psig) air supply pressure.

PERFORMANCE

**GPS820/GPS830 METAL
EZ-INSTALL TPE-FITTED**

Ship Weight...820 Threaded AL 47 kg (104 lb)
820 Threaded SS 73 kg (161 lb)
830 Flanged AL 54 kg (118 lb)
830 Flanged SS 81 kg (178 lb)
Air Inlet.....3/4"
Inlet.....51 mm (2")
Outlet.....51 mm (2")
Suction Lift.....5.5 m Dry (18.2')
9.0 m Wet (29.5')
Disp. per Stroke¹.....2.1 L (0.55 gal)
Max. Flow Rate.....645 lpm (171 gpm)
Max. Size Solids.....6.4 mm (1/4")

¹Displacement per stroke was calculated at 4.8 bar (70 psig) air inlet pressure against a 2.1 bar (30 psig) head pressure.

Example: To pump 416 lpm (110 gpm) against a discharge head of 2.1 bar (30 psig) requires 5.5 bar (80 psig) and 102 Nm³/h (60 scfm) air consumption.

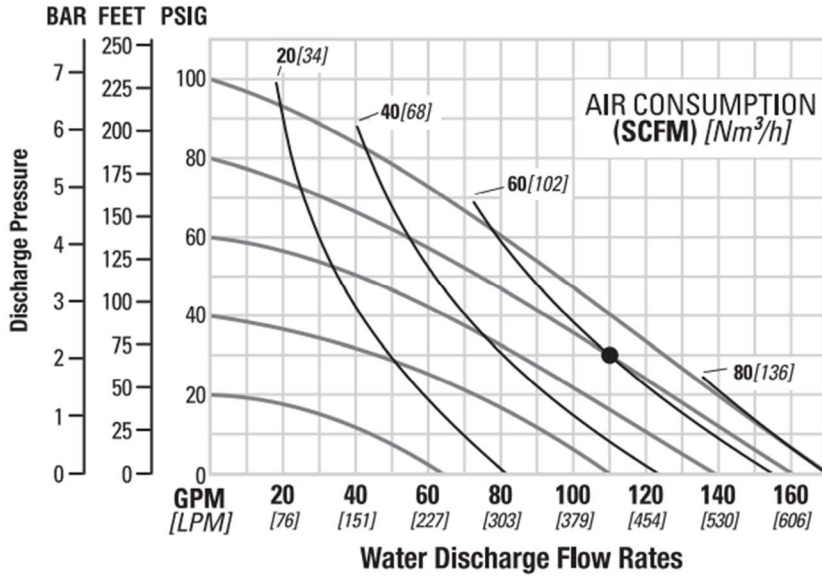

Flow rates indicated on chart were determined by pumping water. For optimum life and performance, pumps should be specified so that daily operation parameters will fall in the center of the pump's performance curve.

Caution: Do not exceed 6.9 bar (100 psig) air supply pressure.

**GPS820/GPS830 METAL
FULL-STROKE
PTFE-FITTED**

Ship Weight...820 Threaded AL 47 kg (104 lb)
820 Threaded SS 73 kg (161 lb)
830 Flanged AL 54 kg (118 lb)
830 Flanged SS 81 kg (178 lb)
Air Inlet.....3/4"
Inlet.....51 mm (2")
Outlet.....51 mm (2")
Suction Lift.....6.1 m Dry (20.0')
9.0 m Wet (29.5')
Disp. per Stroke¹.....2.4 L (0.63 gal)
Max. Flow Rate.....636 lpm (168 gpm)
Max. Size Solids.....6.4 mm (1/4")

¹Displacement per stroke was calculated at 4.8 bar (70 psig) air inlet pressure against a 2.1 bar (30 psig) head pressure.

Example: To pump 379 lpm (100 gpm) against a discharge head of 2.1 bar (30 psig) requires 5.5 bar (80 psig) and 112 Nm³/h (66 scfm) air consumption.

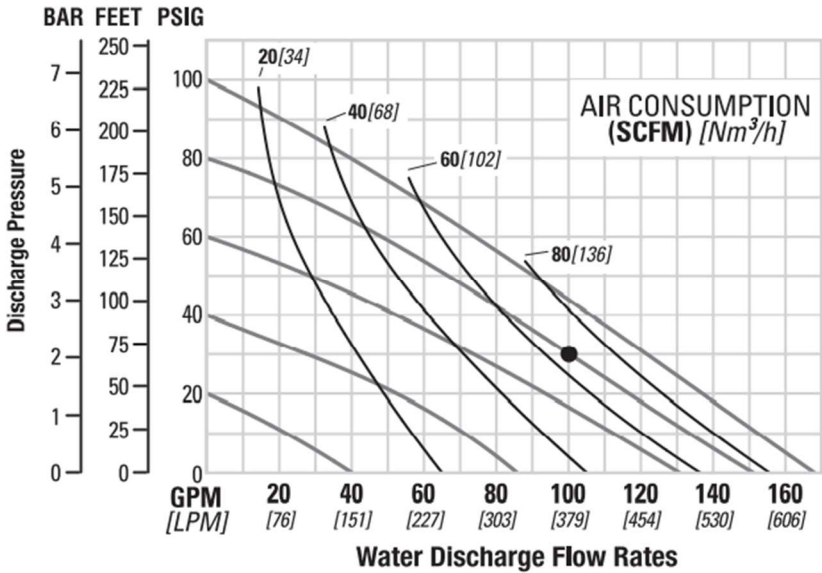

Flow rates indicated on chart were determined by pumping water. For optimum life and performance, pumps should be specified so that daily operation parameters will fall in the center of the pump's performance curve.

Caution: Do not exceed 6.9 bar (100 psig) air supply pressure.

PERFORMANCE

**GPS1520/GPS1530 METAL
EZ-INSTALL TPE-FITTED**

Ship Weight:
1520 Threaded AL 69 kg (152 lb)
1520 Threaded SS 126 kg (278 lb)
1530 Flanged SS 137 kg (300 lb)

Air Inlet.....3/4"
Inlet.....76 mm (3")
Outlet.....76 mm (3")
Suction Lift.....4.7 m Dry (15.3')
 9.0 m Wet (29.5')
Disp. per Stroke¹.....4.2 L (1.11 gal)
Max. Flow Rate.....884 lpm (234 gpm)
Max. Size Solids.....12.7 mm (1/2")

¹Displacement per stroke was calculated at 4.8 bar (70 psig) air inlet pressure against a 2.1 bar (30 psig) head pressure.

Example: To pump 659 lpm (174 gpm) against a discharge head of 1.4 bar (20 psig) requires 5.5 bar (80 psig) and 143 Nm³/h (84 scfm) air consumption.

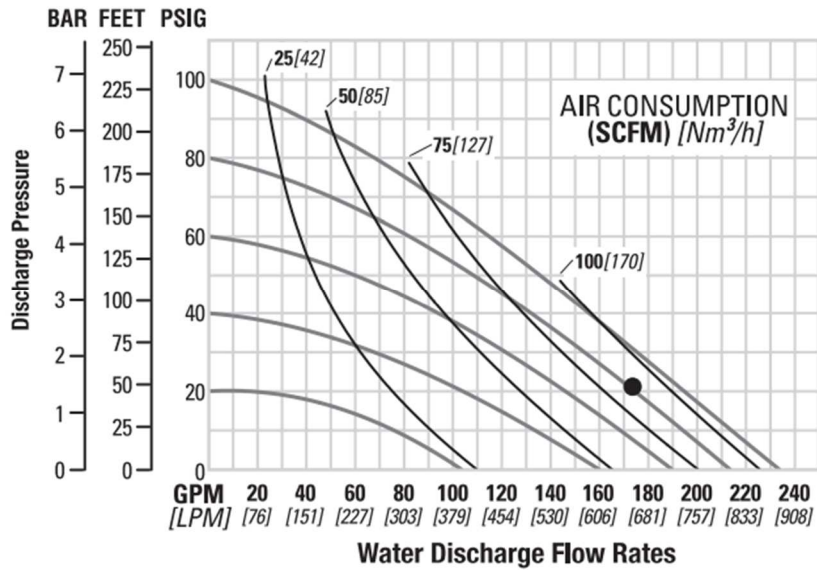

Flow rates indicated on chart were determined by pumping water. For optimum life and performance, pumps should be specified so that daily operation parameters will fall in the center of the pump's performance curve.

Caution: Do not exceed 6.9 bar (100 psig) air supply pressure.

**GPS1520/GPS1530 METAL
FULL-STROKE
PTFE-FITTED**

Ship Weight:
1520 Threaded AL 69 kg (152 lb)
1520 Threaded SS 126 kg (278 lb)
1530 Flanged SS 137 kg (300 lb)

Air Inlet.....3/4"
Inlet.....76 mm (3")
Outlet.....76 mm (3")
Suction Lift.....5.9 m Dry (19.3')
 8.6 m Wet (28.4')
Disp. per Stroke¹.....5.0 L (1.32 gal)
Max. Flow Rate.....993 lpm (246 gpm)
Max. Size Solids.....12.7 mm (1/2")

¹Displacement per stroke was calculated at 4.8 bar (70 psig) air inlet pressure against a 2.1 bar (30 psig) head pressure.

Example: To pump 420 lpm (111 gpm) against a discharge head of 2.8 bar (40 psig) requires 4.8 bar (70 psig) and 110 Nm³/h (65 scfm) air consumption.

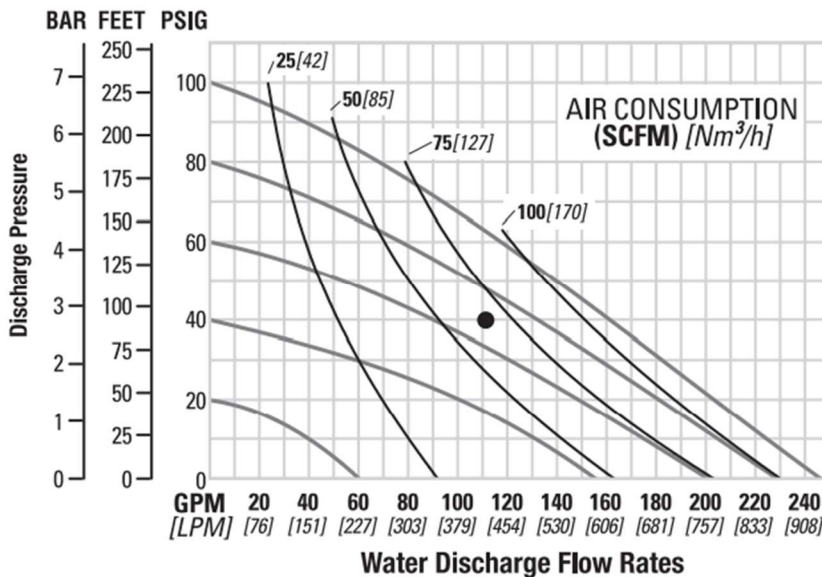

Flow rates indicated on chart were determined by pumping water. For optimum life and performance, pumps should be specified so that daily operation parameters will fall in the center of the pump's performance curve.

Caution: Do not exceed 6.9 bar (100 psig) air supply pressure.

SUCTION LIFT CAPABILITY

**GPS420/GPS430
 SUCTION LIFT
 CAPABILITY**

Suction-lift curves are calibrated for pumps operating at 305 m (1,000') above sea level. This chart is meant to be a guide only. There are many variables that can affect your pump's operating characteristics. The number of intake and discharge elbows, viscosity of pumping fluid, elevation (atmospheric pressure) and pipe friction loss all affect the amount of suction lift your pump will attain.

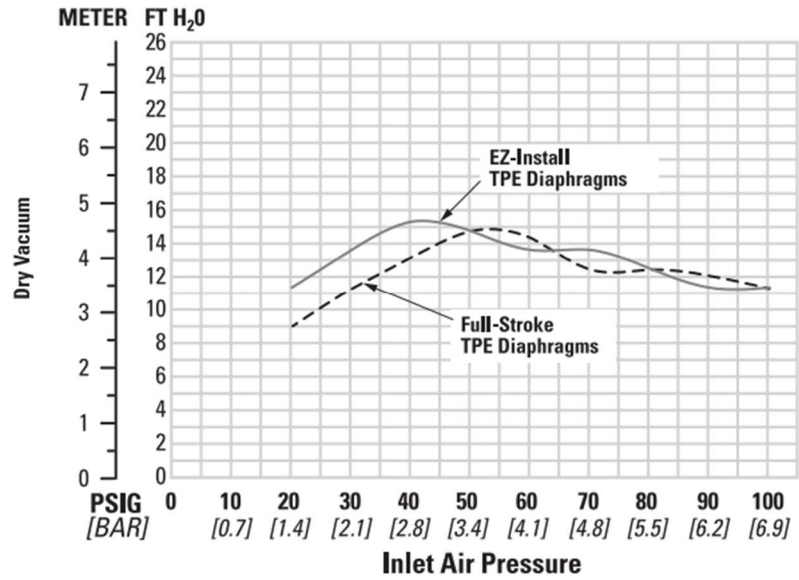

**GPS820/GPS830
 SUCTION LIFT
 CAPABILITY**

Suction-lift curves are calibrated for pumps operating at 305 m (1,000') above sea level. This chart is meant to be a guide only. There are many variables that can affect your pump's operating characteristics. The number of intake and discharge elbows, viscosity of pumping fluid, elevation (atmospheric pressure) and pipe friction loss all affect the amount of suction lift your pump will attain.

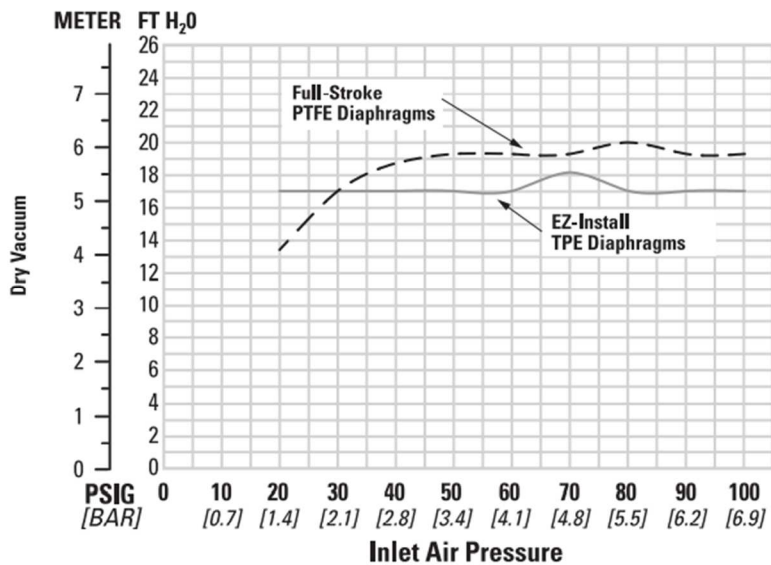

SUCTION LIFT CAPABILITY

**GPS1520/GPS1530
 SUCTION LIFT
 CAPABILITY**

Suction-lift curves are calibrated for pumps operating at 305 m (1,000') above sea level. This chart is meant to be a guide only. There are many variables that can affect your pump's operating characteristics. The number of intake and discharge elbows, viscosity of pumping fluid, elevation (atmospheric pressure) and pipe friction loss all affect the amount of suction lift your pump will attain.

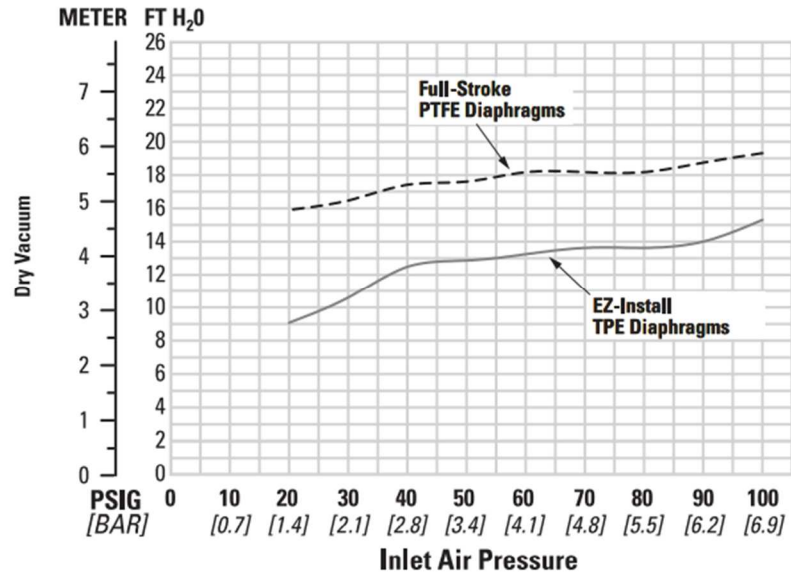

SECTION 6

SUGGESTED INSTALLATION, OPERATION, MAINTENANCE AND TROUBLESHOOTING

Prior to pump installation, ensure that the flow and suction lift requirements are within the pump model's capabilities. Refer to the Section 5, Performance of the Engineering, Operation and Maintenance (EOM) Manual for specific flow and suction-lift capabilities.

Before installation confirm that the pump materials of construction are compatible with pumping application. Refer to the Wilden Chemical Resistance Guide for assistance with wetted path and elastomer options.

Piping

The pump should be located so that the length and complexity of the suction and discharge piping is minimized. Unnecessary elbows, bends and fittings can increase friction losses and should be avoided.

Pipe sizes should be selected to keep friction losses within practical limits. The suction pipe diameter should be equivalent or larger than the diameter of the suction inlet on your Wilden pump. The suction hose must be non-collapsible, reinforced type as these pumps are capable of pulling a high vacuum. Discharge piping should also be the equivalent or larger than the diameter of the pump discharge to help reduce friction losses.

All piping should be supported independently of the pump. In addition, the piping should be correctly aligned with the inlet and discharge connection of the pump to avoid placing stress on the pump fittings. Flexible hose can be installed to aid in absorbing the forces created by the natural reciprocating action of the pump and will also assist in minimizing pump vibration.

Gas Supply

The pump should have a supply line large enough (a 3/4" supply line is recommended for 1-1/2" and larger pumps) to supply the volume of air necessary to achieve the desired pumping rate. Gas pressure to the pump should be controlled by a pressure-regulating valve and should not exceed a maximum of 6.9 bar (100 psig). It is suggested that a needle valve be placed in the supply line to control the flow of gas to the pump. For best results, a 5µ (micron) filter should be installed before the gas inlet of the pump to eliminate the majority of compressed gas line contaminants.

Type of Gas

Sweet gas is required for natural gaspowered pumps. Please consult the factory if considering using sour gas as levels of hydrogen sulfide (H2S) may cause unacceptable corrosion and chemical attack.

Pump Mounting and Installation

For simple installation and removal of the pump shut-off valves should be installed in the inlet and discharge plumbing. If the pump is to be mounted in a fixed location, a mounting pad placed between the pump and the foundation will assist in minimizing pump vibration. If quick-closing valves are installed at any point in the discharge system, or if pulsation within a system becomes a problem, a surge suppressor should be installed to protect the pump, piping and gauges from surges and water hammer.

Solids Passage

All Wilden pumps are capable of passing solids. A strainer should be used at the inlet of the pump to ensure that the pump's rated solids capabilities are not exceeded. Refer to the Section 5 of this EOM manual for specific solids-passage capabilities.

Flooded Suction

Pumps in service with a positive suction head are most efficient when the inlet pressure is limited to 0.5–0.7 bar (7–10 psig). Premature diaphragm failure may occur if positive suction is 0.7 bar (10 psig) or higher.

Suction Lift

When used in self-priming applications, it is critical that all fittings and connections are airtight, or a reduction or loss of pump suction capability will result.

Gas Outlet

All CSA-certified pumps are fitted with the single point exhaust option so that all exhaust gases are routed through the muffler plate exhaust port. The gas outlet must be recaptured or vented to a safe location in accordance with locally, nationally and/or industry recognized codes.

Grounding

Pumps and accessories must be electrically grounded to a proper grounding point to prevent an accumulation of electro-static charge when used in potentially explosive areas. CSA-certified pumps come with a grounding strap and are fitted with a grounding screw for the purpose of electrically grounding the pump. Periodic inspection of the ground connection should be performed to ensure the equipment is properly grounded. Refer to the Wilden CE Safety Supplement and Safety Manual for additional ATEX-certified pump considerations.

Functional Testing

1. Tighten all hardware prior to initial start-up. Refer to Section 7, Reassembly Hints & Tips in the EOM manual for torque specifications.
2. Prior to pump installation connect compressed gas line [do not exceed rated pressure of 6.9 bar (100 psig)] to gas inlet of pump to ensure that pump cycles consistently.
3. Cycle pump for 2-3 minutes.
4. After pump installation, check piping connections for leaks.

Pump Operation

1. To avoid damage to the pump new installations should be checked for any debris in tank or piping system.
2. Once installation is complete, pump operation can be started. Confirm the shut-off valves in the inlet and discharge plumbing are open. Do not exceed the pump's maximum rated pressure of 6.9 bar (100 psig). A pressure regulating valve and needle valve can be used to adjust the speed of the pump.
3. Retighten all exposed fasteners after two (2) hours of operation. Refer to Section 7, Reassembly Hints & Tips in the EOM manual for torque specifications.

Emergency Shut-Down Procedure

In the case of an emergency situation, the pump should be stopped immediately. To stop the pump's operation, close the gas shut-off valve (user-supplied). A properly functioning valve will cut-off the gas supply, stopping the pump. The shut-off valve should be located far enough away from the pumping equipment such that it can be reached safely in an emergency situation. In the event of pump or diaphragm failure, close shut-off valves at the inlet and discharge of pump to eliminate the possibility of medium leakage. In the event of a power failure, the gas shut-off valve should be closed, if restarting of the pump is not desirable once power is regained.

Refer to the Wilden CE Safety Supplement, Safety Manual and EOM Manual for additional information.

SUGGESTED INSTALLATION, OPERATION, MAINTENANCE AND TROUBLESHOOTING

This illustration is a generic representation of an air-operated double-diaphragm pump.

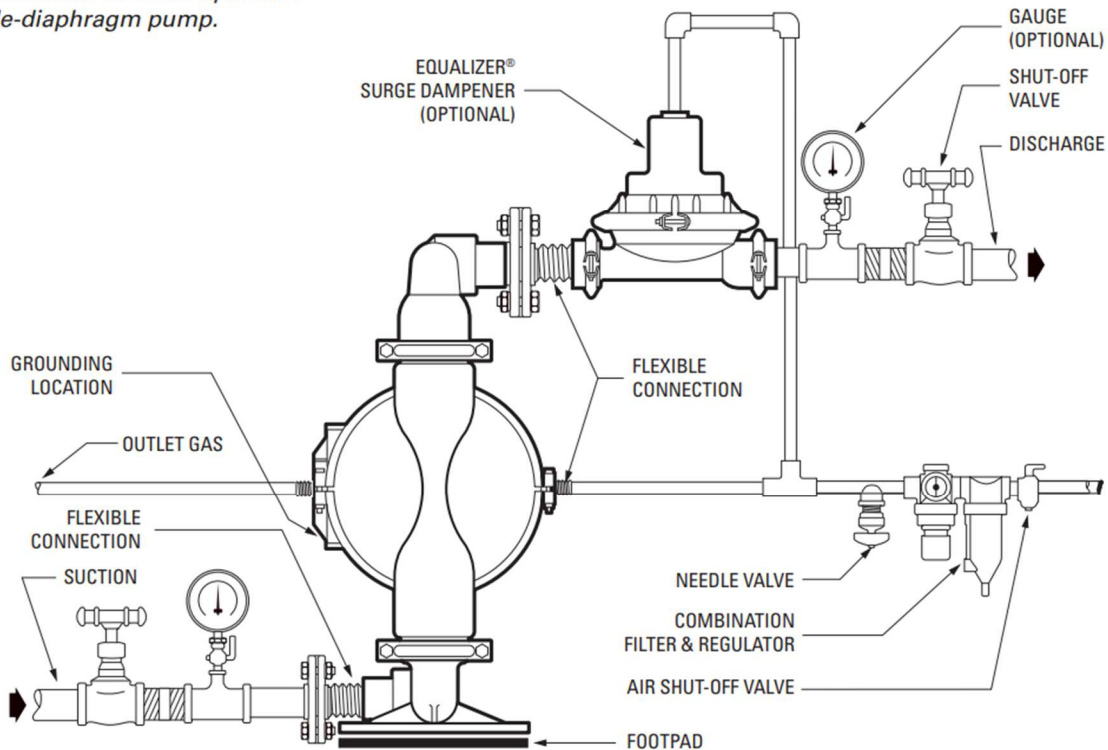

Prior to Maintenance

Before any maintenance is performed, confirm pump is completely de-energized by shutting off the pump and disconnecting the gas supply line to the pump. Refer to Section 7, Reassembly Hints & Tips and Section 8, Exploded View & Parts Listings in the EOM manual for maintenance and spare parts information

Operation

CSA-certified pumps are pre-lubricated, and do not require in-line lubrication. Additional lubrication will not damage the pump, however if the pump is heavily lubricated by an external source, the pump's internal lubrication may be washed away. If the pump is then moved to a non-lubricated location, it may need to be disassembled and re-lubricated as described in the "Disassembly/Reassembly". Pump discharge rate can be controlled by limiting the volume and/or pressure of the air supply to the pump. An air regulator is used to regulate air pressure. A needle valve is used to regulate volume.

Pump discharge rate can also be controlled by throttling the pump discharge by partially closing a valve in the discharge line of the pump. This action increases friction loss which reduces flow rate. (See Section 5.) This is useful when the need exists to control the pump from a remote location. When the pump discharge pressure equals or exceeds the air supply pressure, the pump will stop; no bypass or pressure relief valve is needed, and pump damage will not occur. The pump has reached a "deadhead" situation and can be

restarted by reducing the fluid discharge pressure or increasing the air inlet pressure. CSA-certified pumps run on pressurized sweet gas and do not generate heat; therefore, your process fluid temperature will not be affected.

Maintenance and Inspections

Because each application is unique, maintenance schedules may be different for every pump. Frequency of use, line pressure, viscosity and abrasiveness of process fluid all affect the parts life of a Wilden pump. Periodic inspections have been found to offer the best means for preventing unscheduled pump downtime. Personnel familiar with the pump's construction and service should be informed of any abnormalities that are detected during operation.

Records

When service is required, a record should be made of all necessary repairs and replacements. Over a period of time, such records can become a valuable tool for predicting and preventing future maintenance problems and unscheduled downtime. In addition, accurate records make it possible to identify pumps that are poorly suited to their applications.

SUGGESTED INSTALLATION, OPERATION, MAINTENANCE AND TROUBLESHOOTING

Troubleshooting

Pump will not run or runs slowly.

1. Remove plug from pilot spool exhaust.
2. Ensure that the air inlet pressure is at least 0.4 bar (5 psig) above startup pressure and that the differential pressure (the difference between air inlet and liquid discharge pressures) is not less than 0.7 bar (10 psig).
3. Check air inlet filter for debris (see "Suggested Installation, Operation, Maintenance and Troubleshooting").
4. Check for extreme air leakage (blow by) that would indicate worn seals/bores in the air valve, pilot spool and main shaft.
5. Disassemble the pump and check for obstructions in the air passageways or objects that would obstruct the movement of internal parts.
6. Check for sticking ball check valves.
 - a. If material being pumped is not compatible with pump elastomers, swelling may occur. Replace ball check valves and seals with proper elastomers.
 - b. Also, as the check valve balls wear out, they become smaller and can become stuck in the seats. In this case, replace balls and seats.
7. Check for any broken inner piston that would cause the air valve spool to be unable to shift.

Pump runs, but little or no product flows.

1. Check for pump cavitation. Slow pump speed down to allow thick material to flow into liquid chambers.
2. Verify that vacuum required to lift liquid is not greater than the vapor pressure of the material being pumped (cavitation).
3. Check for sticking ball check valves.
 - a. If material being pumped is not compatible with pump elastomers, swelling may occur. Replace ball check valves and seals with proper elastomers.
 - b. Also, as the check valve balls wear out, they become smaller and can become stuck in the seats. In this case, replace balls and seats.

Pump air valve freezes.

1. Check for excessive moisture in the compressed air.
 - a. Either install a dryer or a hot air generator for compressed air.
 - b. Alternatively, you may use coalescing filter to remove the water from the compressed air in some applications.

Air bubbles in pump discharge.

1. Check for a ruptured diaphragm.
2. Check tightness of outer pistons (see "Disassembly/Reassembly").
3. Check tightness of fasteners and integrity of O-rings and seals, especially at intake manifold.
4. Ensure pipe connections are airtight.

Product comes out air exhaust.

1. Check for a diaphragm rupture.
2. Check the tightness of the outer pistons to the shaft.

SECTION 7

DISASSEMBLY / REASSEMBLY

PUMP DISASSEMBLY

Tools Required:

- 9/16" and 23 mm Socket Wrench (GPS420/430)
- 1" Socket Wrench (GPS820/830)
- 9/16", 5/16" and 1-1/8" Socket Wrench (GPS1520/1530)
- Snap-Ring Pliers
- Vise equipped with soft jaws (such as plywood, plastic or other suitable material)



CAUTION: Before attempting any maintenance or repair, disconnect the compressed air line to the pump and allow all air pressure to bleed from the pump. Disconnect all intake, discharge, and air lines. Drain the pump by turning it upside down and allowing any fluid to flow into a suitable container. Be aware of any hazardous effects of contact with your process fluid.



NOTE: Your specific pump model may vary from the configuration shown; however, pump disassembly procedure will be the same.



NOTE: Replace worn parts with genuine Wilden parts for reliable performance.

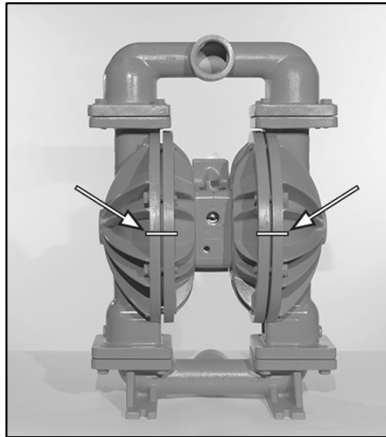

Step 1

Before starting disassembly, mark a line from each liquid chamber to its corresponding air chamber. This line will assist in proper alignment during reassembly.

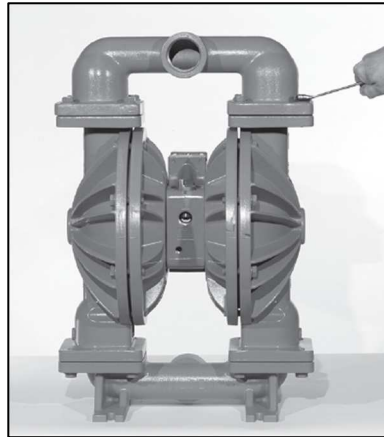

Step 2

Using the appropriate-sized wrench, loosen the discharge manifold from the liquid chambers.

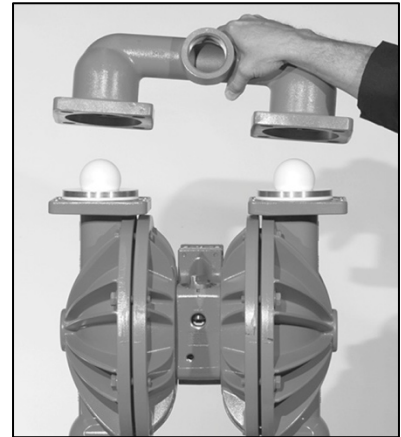

Step 3

Lift the discharge manifold to expose discharge valve balls and valve seats. Inspect ball cage area of manifold for excessive wear or damage.

DISASSEMBLY / REASSEMBLY

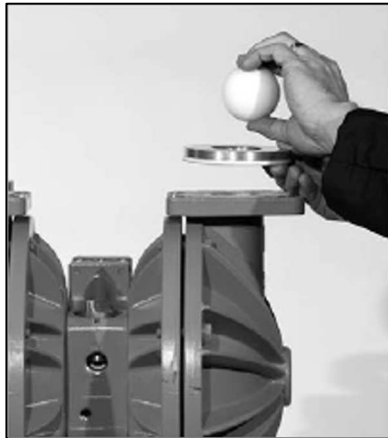

Step 4

Remove the discharge valve balls and valve seats from the liquid chambers and inspect for nicks, gouges, chemical attack or abrasive wear. Replace worn parts with genuine Wilden parts for reliable performance.

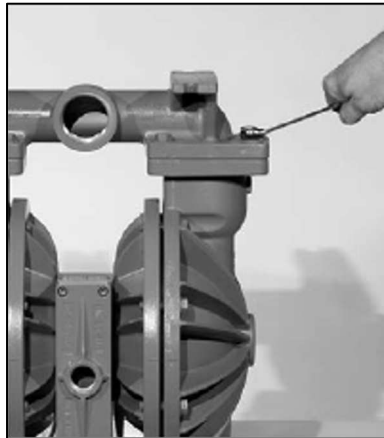

Step 5

Using the appropriate-sized wrench, loosen the inlet manifold from the liquid chambers.

NOTE: Inverting the pump will facilitate removal of inlet manifold.



Step 6

Remove the inlet manifold to expose the valve balls and valve seats. Inspect ball cage area of manifold for excessive wear or damage.

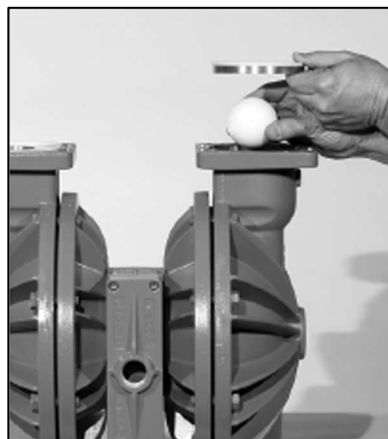

Step 7

Remove the inlet valve balls and valve seats from the inlet manifold and liquid chambers and inspect for nicks, gouges, chemical attack or abrasive wear. Replace worn parts with genuine Wilden parts for reliable performance.

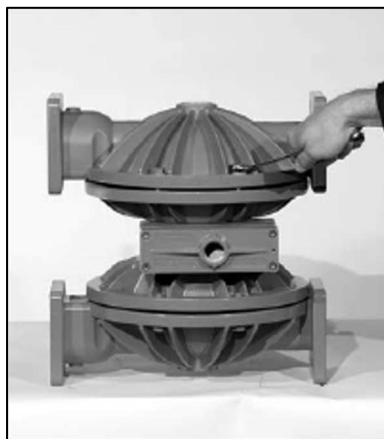

Step 8

Using the appropriate-sized wrench, remove the liquid chamber from the center section.



Step 9

The liquid chamber should be removed to expose the diaphragm and outer piston using an adjustable wrench. Remove the diaphragm assembly from the center section. Repeat for opposite side.

DISASSEMBLY / REASSEMBLY



Step 10

Inspect the diaphragm assembly for wear, damage or chemical attack. Replace any damaged components with genuine Wilden parts for reliable performance.



Step 11

To remove the diaphragm assembly from shaft, secure shaft with soft jaws (aluminum, plastic, or plywood) to ensure the shaft is not damaged. Using an adjustable wrench, remove the diaphragm assembly from the shaft.

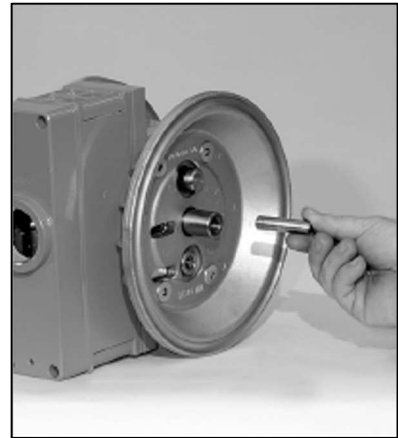

Step 12

Remove outer piston and stud if equipped. Inspect for wear and replace if necessary.

GROUNDING STRAP FOR CSA PUMPS

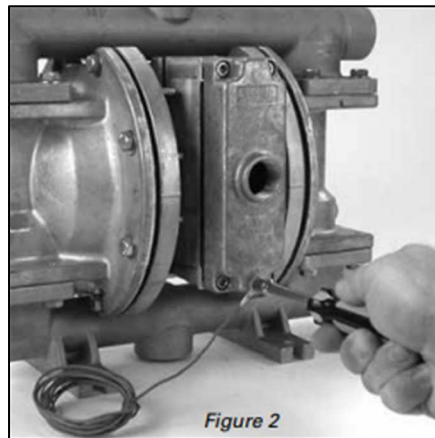
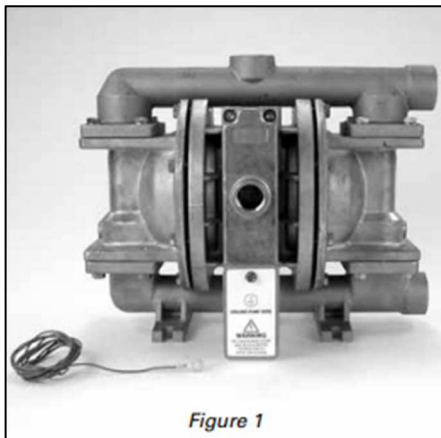

Canadian Standards Association (CSA) configured pumps must be electrically grounded using the grounding strap provided (Figure 1). Improper grounding can cause improper and dangerous operation. To properly attach the grounding strap to a CSA-configured pump, identify the designated grounding location on the muffer plate; using the provided self-tapping screw and grounding wire, thread the grounding screw through the grounding wire lug, into the muffer plate and tighten securely (Figure 2). Completion of the pump grounding procedure must be done in accordance with local codes, or in the absence of local codes, an industrial or nationally recognized code having jurisdiction over the specified installation.

DISASSEMBLY / REASSEMBLY

AIR VALVE / CENTER SECTION DISASSEMBLY

Tools Required:

- 3/16" Hex-Head Wrench
- 1/4" Hex-Head Wrench
- Snap-Ring Pliers
- O-Ring Pick



CAUTION: Before attempting any maintenance or repair, disconnect the compressed air line to the pump and allow all air pressure to bleed from the pump. Disconnect all intake, discharge, and air lines. Drain the pump by turning it upside down and allowing any fluid to flow into a suitable container. Be aware of any hazardous effects of contact with your process fluid.



NOTE: Replace worn parts with genuine Wilden parts for reliable performance.



Step 1

Using a pair of snap-ring pliers, remove the snap ring from the pilot sleeve.



Step 2

Using an O-ring pick, remove the O-ring from modulator spool.



Step 3

Using the appropriate-sized wrench, loosen and remove the fasteners that attach the air chamber to the center section.



Step 4

Lift the air chamber away from the center section and remove the center block gasket. Replace gasket, if necessary.



Step 5

Turn the assembly over and remove the pilot spool sleeve from the center section.

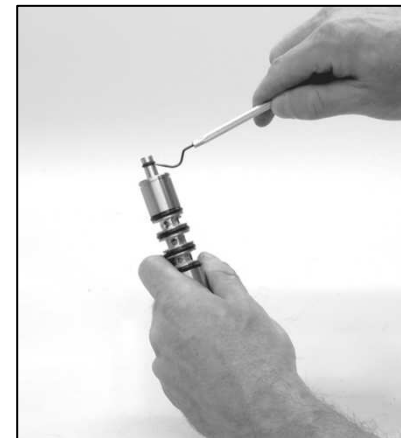

Step 6

Using an O-ring pick, gently remove the O-ring from the opposite side of the dimpled end of the pilot spool.

DISASSEMBLY / REASSEMBLY

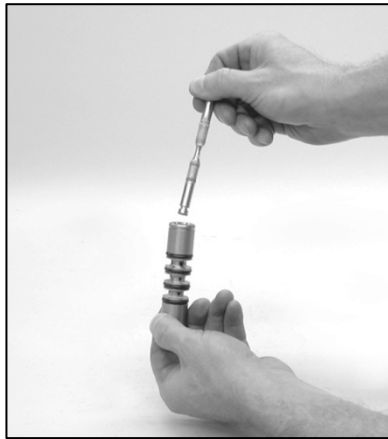

Step 7

Gently remove the pilot spool from the sleeve and inspect for nicks, wear or damage. Replace the pilot spool assembly or sleeve O-rings, if necessary. During reassembly, never insert the dimpled end of the pilot spool first. This will damage the single urethane O-ring bypassing it over the ports in the pilot sleeve.

NOTE: Do not remove seals from the assembly. Seals are not sold separately.



Step 8

Remove the modulator spool from the center section. Check for wear to the spool or O-rings and replace, if necessary.



Step 9

Using the appropriate-sized wrench, loosen the fasteners and lift away remaining air chamber and center block gasket from center section. Replace gasket if necessary.

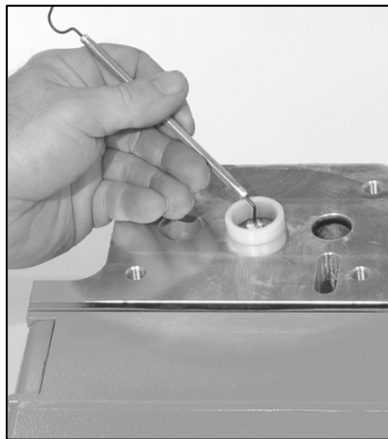

Step 10

Using an O-ring pick, remove the two (2) shaft bushings from center block. Inspect and replace if necessary. Using an O-ring pick, gently remove the two (2) Glyd™ rings from the center block. Inspect and replace if necessary.

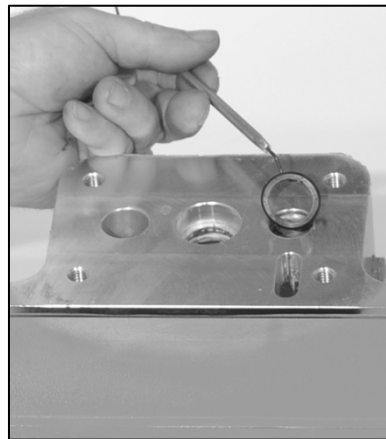

Step 11

Using an O-ring pick, remove the two (2) Glyd™ rings from modulator spool bore. Inspect and replace if necessary.

DISASSEMBLY / REASSEMBLY

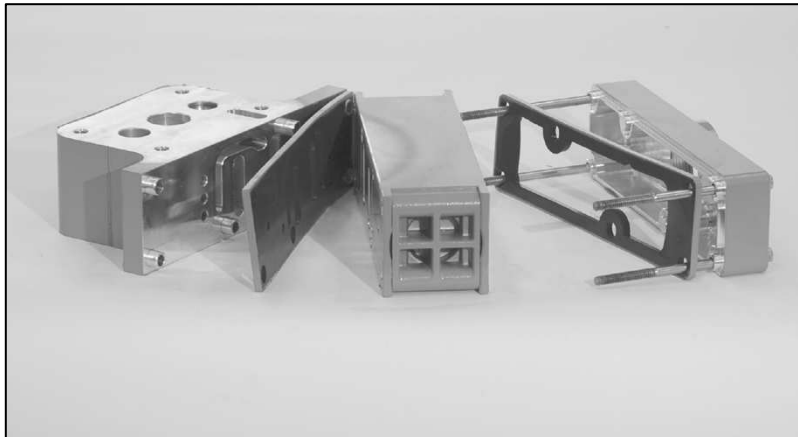

Step 12

Loosen and remove the four (4) air valve bolts from the center section assembly.

Lift the muffer plate and muffer plate gasket away from the center block. Inspect for wear and replace, if necessary.

Lift the air valve assembly and remove the air valve gasket. Inspect the gasket and replace, if necessary.

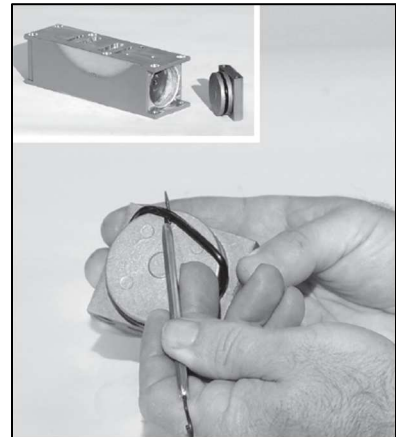

Step 13

Remove the air valve end cap to expose the air valve spool by lifting up on the end cap. Inspect the O-ring on the end cap using an O-ring pick. Replace the O-ring(s), if necessary.

NOTE: The Pro-Flo SHIFT air valve incorporates an end cap at both ends of the air valve.

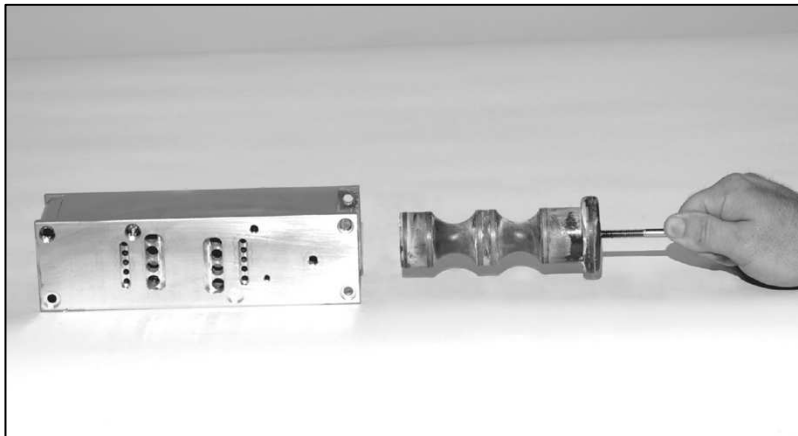

Step 14

Remove the air valve spool from the air valve body by threading one air valve bolt into the end of the air valve spool and gently sliding the spool out of the air valve body. Inspect seals for signs of wear and replace the entire air valve assembly, if necessary. Re-insert the spool immediately into the air valve body after inspection because the seals expand and cannot be reinserted after a length of time.

NOTE: Do not remove seals from the assembly. Seals are not sold separately.

DISASSEMBLY / REASSEMBLY

SINGLE-POINT EXHAUST

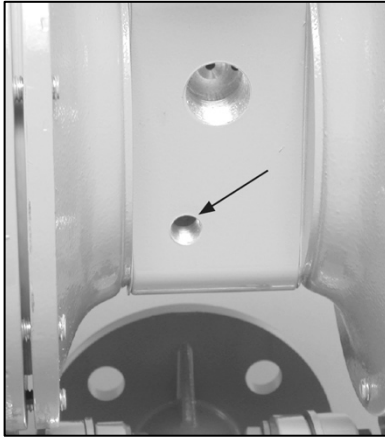

Step 1

Remove the pilot exhaust muffler in the pilot bleed port located at the front of the center block. Install 1/4" NPT pipe plug (00-7010-08) into the bleed port.

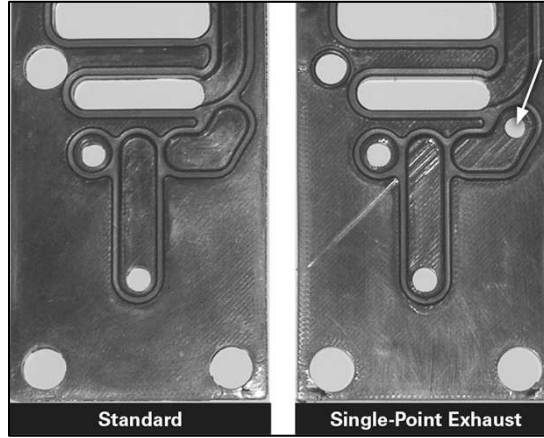

Step 2

Optional: Install a single-point exhaust gasket (04-2639-52). The single-point air valve gasket can be purchased as a spare part or included with the purchase of a new Pro-Flo SHIFT pump.

REASSEMBLY HINTS AND TIPS

Upon performing applicable maintenance to the air distribution system, the pump can now be reassembled. Please refer to the disassembly instructions for photos and parts placement.

To reassemble the pump, follow the disassembly instructions in reverse order. The air distribution system needs to be assembled first, then the diaphragms and finally the wetted path. The applicable torque specifications are on this page.

The following tips will assist in the assembly process:

- Lubricate the air valve bore, center section shaft and pilot spool bore with NLGI grade 2 white EP bearing grease or equivalent.
- Clean the inside of the center section shaft bore to ensure no damage is done to new shaft seals.
- A small amount of NLGI grade 2 white EP bearing grease can be applied to the muffler and air valve gaskets to lubricate gaskets during assembly.
- Make sure that the exhaust port on the muffler plate is centered between the two exhaust ports on the center section.
- Stainless bolts should be lubed to reduce the possibility of seizing during tightening.

Maximum Torque Specifications	
Description	Torque
Air Valve (Aluminum, Stainless Steel)	13.6 N·m (120 in-lb)
Air Chamber/Center Block	27.1 N·m (20 ft-lb)
Outer Pistons (GPS420/430)	54.2 N·m (40 ft-lb)
Outer Pistons, Aluminum (GPS820/830)	109 N·m (80 ft-lb)
Outer Pistons, Stainless Steel (GPS820/830)	119 N·m (88 ft-lb)
Outer Pistons (GPS1520/1530)	136 N·m (100 ft-lb)
Liquid Chamber to Air Chamber (GPS420/430)	47.5 N·m (35 ft-lb)
Liquid Chamber to Air Chamber (GPS820/830)	75.6 N·m (55 ft-lb)
Liquid Chamber to Air Chamber (GPS1520/1530)	149 N·m (110 ft-lb)
Manifolds to Liquid Chamber (GPS420/430)	47.5 N·m (35 ft-lb)
Manifolds to Liquid Chamber (GPS820/830)	75.6 N·m (55 ft-lb)
Manifolds to Liquid Chamber (GPS1520/1530)	149 N·m (110 ft-lb)
Inner Piston Ring (GPS1520/1530)	19 N·m (14 ft-lb)

DISASSEMBLY / REASSEMBLY

SHAFT SEAL INSTALLATION

Pre-Installation

After all the old seals have been removed, the inside of the bushing should be cleaned to ensure no debris is left that may cause premature damage to the new seals.

Installation

1. To prevent damaging the inside surface of the new seal, wrap electrical tape around each leg of the needle-nose pliers. (Heat shrink tubing may also be used.)
2. With a new seal in hand, place the two legs of the needle-nose pliers inside the seal ring. (See Figure A.)
3. Open the pliers as wide as the seal diameter will allow, then with two fingers pull down on the top portion of the seal to form a kidney bean shape. (See Figure B.)
4. Lightly clamp the pliers together to hold the seal into the kidney shape. Be sure to pull the seal into as tight of a kidney shape as possible. This will allow the seal to travel down the bushing bore with greater ease.
5. With the seal clamped in the pliers, insert the seal into the bushing bore and position the bottom of the seal into the correct groove. When the bottom of the seal is seated in the groove, release the clamp pressure on the pliers. This will allow the seal to partially snap back to its original shape.
6. After removing the pliers, you will notice a slight bump in the seal shape. Before the seal can be resized properly, the bump in the seal should be removed as much as possible. This can be done with either a Phillips screwdriver or your finger. With the side of the screwdriver or your finger, apply light pressure to the peak of the bump. This pressure will cause the bump to be eliminated almost completely.
7. Lubricate the edge of the shaft with NLGI grade 2 white EP bearing grease.
8. Slowly insert the center shaft with a rotating motion. This will complete the resizing of the seal.
9. Repeat these steps for the remaining seals.

Tools

The following tools can be used to aid in the installation of the new seals:

- Needle-Nose Pliers
- Phillips Screwdriver
- Electrical Tape

Figure A

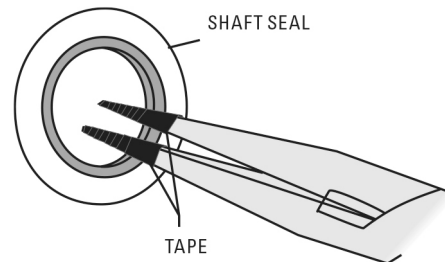
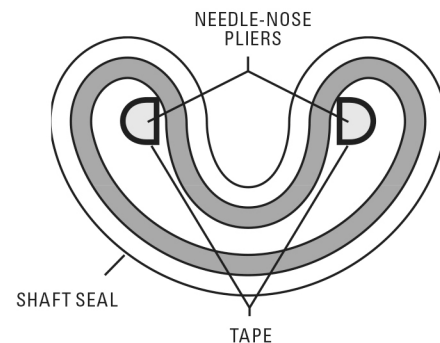

Figure B



SECTION 8

EXPLODED VIEW AND PARTS LIST

GPS420/GPS430 METAL

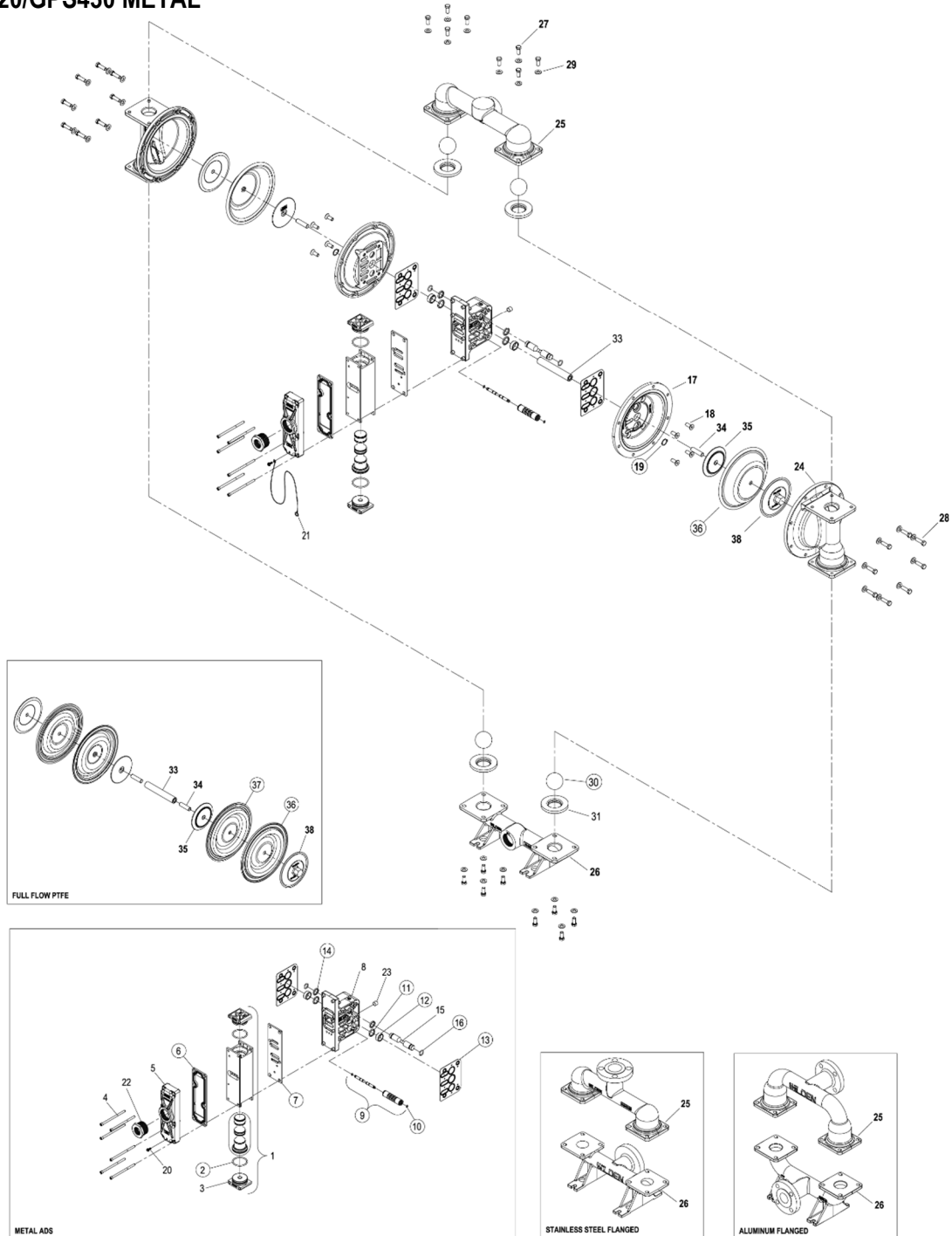

ALL CIRCLED PART IDENTIFIERS ARE INCLUDED IN REPAIR KITS

LW0299 REV. G

EXPLODED VIEW AND PARTS LIST

Item	Description	Model Description	Qty.	GPS420/430/SSSAA/.../ P/N	GPS420/430/SSSSS/.../ P/N	GPS420/430/AAAAA/.../ P/N
Air Distribution Components						
1	Air Valve Assembly, Pro-Flo® Shift ¹		1	04-2039-01	04-2039-03	04-2039-01
2	O-Ring, End Cap (-225, Ø1.859" x Ø.139")		2		04-2390-52-700	
3	End Cap		2	04-2340-01	04-2340-03	04-2340-01
4	Screw, SHC, Air Valve (1/4"-20 x 4 1/2")		6		01-6000-03	
5	Muffler Plate, Pro-Flo® SHIFT		1	04-3189-01	04-3189-03	04-3189-01
6	Gasket, Muffler Plate, Pro-Flo® Shift		1		04-3509-52	
7	Gasket, Air Valve, Pro-Flo® Shift		1		04-2638-52	
8	Center Block Assembly, Pro-Flo® Shift ²		1	04-3129-01	04-3129-03	04-3129-01
9	Pilot Sleeve Assembly		1		04-3880-99	
10	Pilot Spool Retaining O-Ring (-009, Ø.208" x Ø.070")		2		04-2650-49-700	
11	Seal, Shaft		2		08-3210-55-225	
12	Bushing, Shaft		2		08-3306-13	
13	Gasket, Center Block Pro-Flo Shift™		2		04-3529-56	
14	Seal, Air Control Spool		2		04-3219-49	
15	Air Control Spool		1		04-3859-03	
16	Air Control Spool Retaining O-Ring (-114, Ø.612" x Ø.103")		2		04-3879-50	
17	Air Chamber, Pro-Flo V™		2	04-3698-03	04-3698-03	04-3694-01
18	Screw, HSFHS (3/8"-16 x 1")		8	71-6250-08	71-6250-03	71-6250-08
19	Retaining Ring		2		04-3890-03	
20	Grounding Screw, (10-32 x 1/2") Self Tapping		1		04-6345-08	
21	Grounding Strap, CSA		1		01-8303-99	
22	Bushing Reducer 1-1/2" MNPT to 1" FNPT		1	04-6959-08	04-6959-03	04-6959-08
23	Plug, Pipe, 1/4" MNPT		1	00-7010-08	00-7010-03	00-7010-08
Wetted Path Components						
24	Liquid Chamber		2		04-5015-03	04-5015-01
25	Manifold, Discharge, 1-1/2" (NPT)		1		04-5035-03	04-5035-01
	Manifold, Discharge, 1-1/2" (BSPT)		1		04-5036-03	04-5036-01
	Manifold, Discharge, 1-1/2" (ANSI)		1		04-5045-03	04-5045-01
	Manifold, Discharge, 1-1/2" (DIN)		1		04-5046-03	04-5046-01
26	Manifold, Inlet, 1-1/2" (NPT)		1		04-5095-03	04-5095-01
	Manifold, Inlet, 1-1/2" (BSPT)		1		04-5096-03	04-5096-01
	Manifold, Inlet, 1-1/2" (ANSI)		1		04-5125-03	04-5125-01
	Manifold, Inlet, 1-1/2" (DIN)		1		04-5126-03	04-5126-01
27	Screw, HHC (3/8"-16 x 1")		16		08-6130-03	
28	Screw, HHC (3/8"-16 x 1-1/4")		16		04-6190-03	04-6140-08
29	Washer, Flat, (Ø.406" x Ø.812" x .065")		32		04-6740-03	15-6740-08-50
Valve Balls/Valve Seats/Valve O-Rings						
30	Ball, Valve		4		08-1080-58-50	
	Ball, Valve, PTFE Fitted		4		04-1085-55	
31	Seat, Valve		4		04-1128-58	
	Seat, Valve, PTFE Fitted		4	04-1129-03		04-1129-01
32	Valve Seat O-Ring, PTFE Fitted (-338, Ø3.100" x Ø.210") (not shown)		4		71-1281-55	
TPE/PTFE Components						
33	Shaft, Stallion		1		04-3848-03	
	Shaft, PTFE Fitted		1		04-3800-03-700	
34	Shaft Stud, 1/2"-20 X 1-7/8"		2		08-6150-08	
35	Piston, Inner		2		04-3700-01-700	
36	Diaphragm, Primary		2		04-1022-58	
	Diaphragm, Primary, PTFE Fitted		2		04-1040-55-42	
37	Diaphragm, Back-Up, PTFE Fitted		2		04-1065-57	
38	Piston, Outer		2	04-4550-03		04-4552-01

LW0300 Rev. G

¹ Air Valve Assembly includes items 2 and 3.

² Metal Center Block Assembly includes item 11, 12 and 14.

All boldface items are primary wear parts.

EXPLODED VIEW AND PARTS LIST

GPS820/GPS830 ALUMINUM

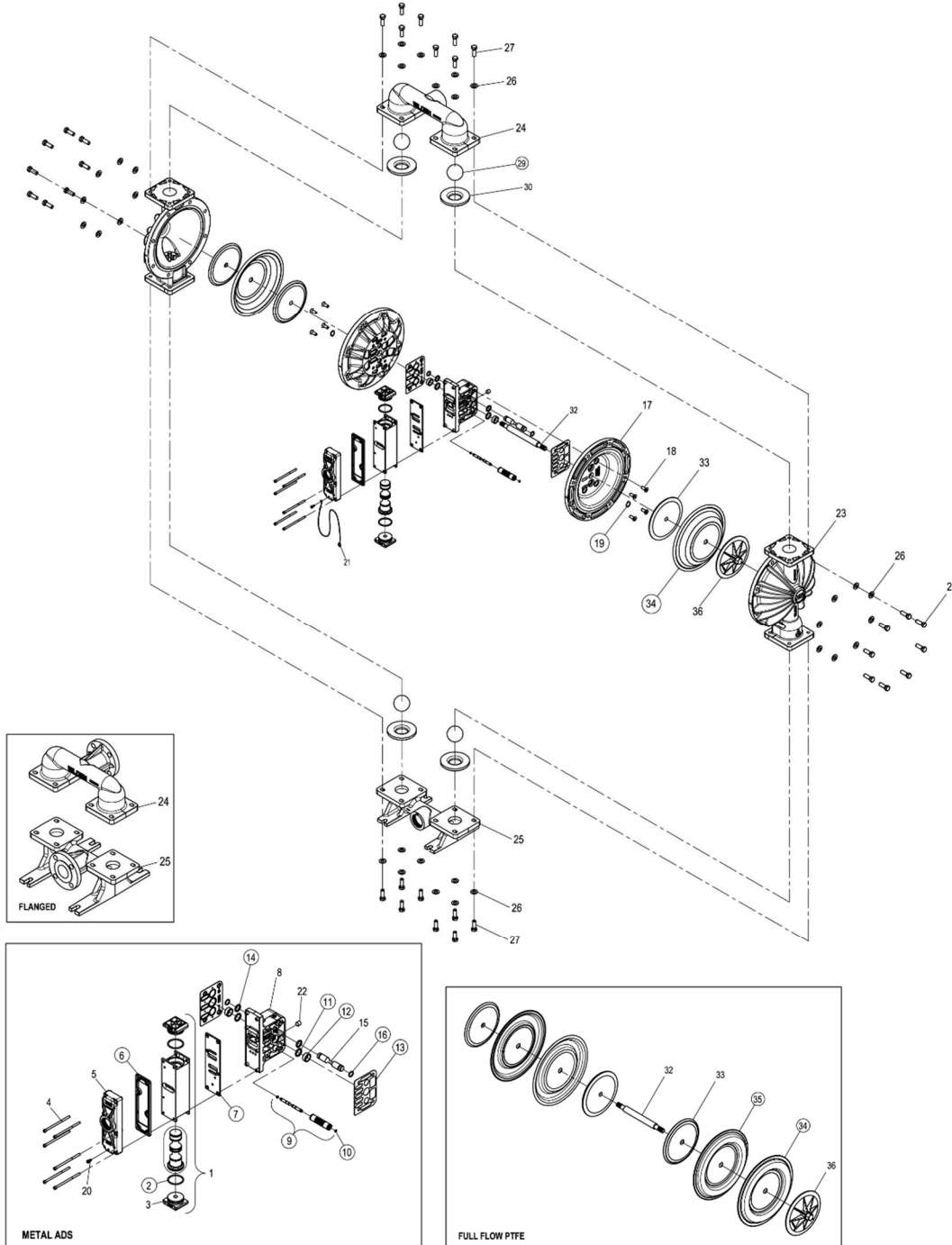

ALL CIRCLED PART IDENTIFIERS ARE INCLUDED IN REPAIR KITS

LW0301 REV. F

EXPLODED VIEW AND PARTS LIST

Item	Description	Model Description	Qty.	GPS820/830/AAAAA.../ P/N
Air Distribution Components				
1	Air Valve Assembly, Pro-Flo Shift™ 1		1	04-2039-01
2	O-Ring, End Cap (-225, Ø1.859" x Ø.139")		2	04-2390-52-700
3	End Cap		2	04-2340-01
4	Screw, SHC, Air Valve (1/4"-20 x 4-1/2")		6	01-6000-03
5	Muffler Plate, Pro-Flo Shift™		1	04-3189-01
6	Gasket, Muffler Plate, Pro-Flo Shift™		1	04-3509-52
7	Gasket, Air Valve, Pro-Flo Shift™		1	04-2638-52
8	Center Block Assembly, Pro-Flo Shift™ 2		1	04-3129-01
9	Pilot Sleeve Assembly		1	04-3880-99
10	O-Ring, Pilot Spool Retaining (-009, Ø.208" x Ø.070")		2	04-2650-49-700
11	Seal, Shaft		2	08-3210-55-225
12	Bushing, Shaft		2	08-3306-13
13	Gasket, Center Block Pro-Flo V™		2	04-3529-56
14	Seal, Air Control Spool		2	04-3219-49
15	Air Control Spool		1	04-3859-03
16	O-ring, Air Control Spool Retaining (-114, Ø.612" x Ø.103")		2	04-3879-50
17	Air Chamber, Pro-Flo X™ Drop-In		2	08-3694-01
18	Screw, HSFHS (3/8"-16 x 1")		8	71-6250-08
19	Retaining Ring		2	04-3890-03
20	Grounding Screw, (10-32 x 1/2") Self Tapping		1	04-6345-08
21	Grounding Strap, CSA		1	01-8303-99
22	Plug, Pipe, 1/4" MNPT		1	00-7010-08
Wetted Path Components				
23	Liquid Chamber, Bolted		2	08-5015-01
24	Manifold, Discharge (NPT)		1	08-5035-01
	Manifold, Discharge (BSPT)		1	08-5036-01
	Manifold, Discharge (ANSI)		1	08-5045-01
	Manifold, Discharge (DIN)		1	08-5046-01
25	Manifold, Inlet (NPT)		1	08-5095-01
	Manifold, Inlet (BSPT)		1	08-5096-01
	Manifold, Inlet (ANSI)		1	08-5125-01
	Manifold, Inlet (DIN)		1	08-5126-01
26	Washer, Flat (Ø.531" x Ø1.062" x .095")		32	04-6730-08
27	Screw, HHC (1/2"-13 x 1-3/4")		16	08-6190-08
28	Screw, HHC (1/2"-13 x 2")		16	04-6210-08
Gaskets/Valve Balls/Valve Seats/Valve O-Rings				
29	Ball, Valve		4	08-1080-58
	Ball, Valve, PTFE Fitted		4	08-1080-55
30	Seat, Valve		4	08-1128-58
	Seat, Valve, PTFE Fitted		4	08-1129-01
31	O-Ring, Valve Seat PTFE Fitted, (-347, Ø4.225 x Ø.210) (not shown)		4	08-1209-55
TPE/PTFE Components				
32	Shaft, Stallion		1	08-3848-03
	Shaft, PTFE Fitted		1	08-3812-03
33	Piston, Inner		2	08-3700-01
34	Diaphragm, Primary		2	08-1022-58
	Diaphragm, Primary, PTFE Fitted		2	08-1040-55-42
35	Diaphragm, Back-Up, PTFE Fitted		2	08-1065-57
36	Piston, Outer		2	08-4550-01

LW0302 Rev. G

¹ Air Valve Assembly includes items 2 and 3.

² Metal Center Block Assembly includes item 11, 12, 14, 15 and 16.

All boldface items are primary wear parts.

EXPLODED VIEW AND PARTS LIST

GPS820/GPS830 STAINLESS STEEL

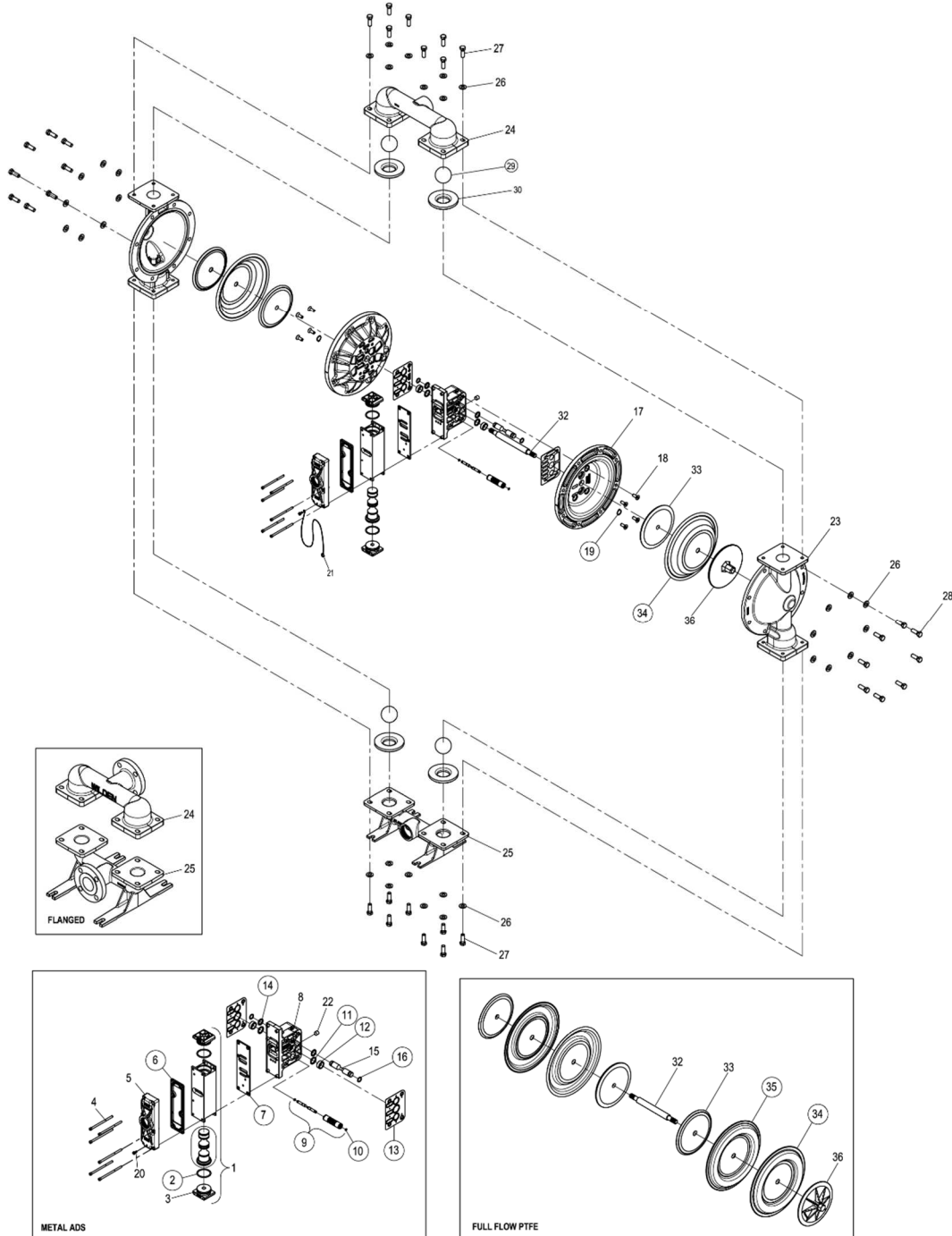

ALL CIRCLED PART IDENTIFIERS ARE INCLUDED IN REPAIR KITS

LW0303 REV. E

EXPLODED VIEW AND PARTS LIST

Item	Description	Qty.	Model Description	GPS820/830/SSSAA/.../	GPS820/830/SSSS/.../
				P/N	P/N
Air Distribution Components					
1	Air Valve Assembly, Pro-Flo Shift™ 1	1		04-2039-01	04-2039-03
2	O-Ring, End Cap (-.225, Ø1.859" x Ø.139")	2		04-2390-52-700	
3	End Cap	2		04-2340-01	04-2340-03
4	Screw, SHC, Air Valve (1/4"-20 x 4-1/2")	6		01-6000-03	
5	Muffler Plate, Pro-Flo Shift™	1		04-3189-01	04-3189-03
6	Gasket, Muffler Plate, Pro-Flo Shift™	1		04-3509-52	
7	Gasket, Air Valve, Pro-Flo Shift™	1		04-2638-52	
8	Center Block Assembly, Pro-Flo Shift™ 2, 3	1		04-3129-01	04-3129-03
9	Pilot Sleeve Assembly	1		04-3880-99	
10	O-Ring, Pilot Spool Retaining (-.009, Ø.208" x Ø.070")	2		04-2650-49-700	
11	Seal, Shaft	2		08-3210-55-225	
12	Bushing, Shaft	2		08-3306-13	
13	Gasket, Center Block Pro-Flo V™	2		04-3529-56	
14	Seal, Air Control Spool	2		04-3219-49	
15	Air Control Spool	1		04-3859-03	
16	O-ring, Air Control Spool Retaining (-114, Ø.612" x Ø.103")	2		04-3879-50	
17	Air Chamber, Pro-Flo X™ Drop-In	2		08-3698-03	
18	Screw, HSFHS (3/8"-16 x 1")	8		71-6250-08	71-6250-03
19	Retaining Ring	2		04-3890-03	
20	Grounding Screw, (10-32 x 1/2") Self Tapping	1		04-6345-08	
21	Grounding Strap, CSA	1		01-8303-99	
22	Plug, Pipe, 1/4" MNPT	1		00-7010-08	00-7010-03
Wetted Path Components					
23	Liquid Chamber, Bolted	2		08-5015-03	
24	Manifold, Discharge (NPT)	1		08-5035-03	
	Manifold, Discharge (BSPT)	1		08-5036-03	
	Manifold, Discharge (ANSI)	1		08-5045-03	
	Manifold, Discharge (DIN)	1		08-5046-03	
25	Manifold, Inlet (NPT)	1		08-5095-03	
	Manifold, Inlet (BSPT)	1		08-5096-03	
	Manifold, Inlet (ANSI)	1		08-5125-03	
	Manifold, Inlet (DIN)	1		08-5126-03	
26	Washer, Flat (Ø.531" x Ø1.062" x .095")	32		04-6730-03	
27	Screw, HHC (1/2"-13 x 1-1/2")	16		04-6180-03	
28	Screw, HHC (1/2"-13 x 2")	16		04-6210-03	
Valve Balls/Valve Seats/Valve O-Rings					
29	Ball, Valve	4		08-1080-58	
	Ball, Valve, PTFE Fitted	4		08-1080-55	
30	Seat, Valve	4		08-1128-58	
	Seat, Valve, PTFE Fitted	4		08-1129-03	
31	O-Ring, Valve Seat PTFE Fitted, (-.347, Ø4.225 x Ø.210) (not shown)	4		08-1209-55	
TPE/PTFE Components					
32	Shaft, Stallion	1		08-3848-03	
	Shaft, PTFE Fitted	1		08-3812-03	
33	Piston, Inner	2		08-3700-01	08-3700-03
34	Diaphragm, Primary	2		08-1022-58	
	Diaphragm, Primary, PTFE Fitted	2		08-1040-55-42	
35	Diaphragm, Back-Up, PTFE Fitted	2		08-1065-57	
36	Piston, Outer	2		08-4550-03	

LW0304 Rev. H

¹ Air Valve Assembly includes items 2 and 3.

² Metal Center Block Assembly includes item 11, 12 and 14.

All boldface items are primary wear parts.

EXPLODED VIEW AND PARTS LIST

GPS1520 ALUMINUM

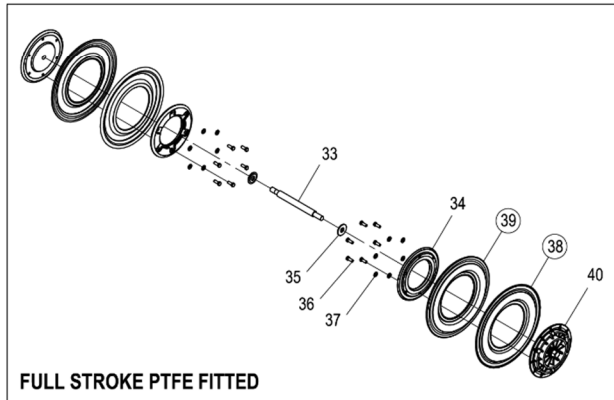
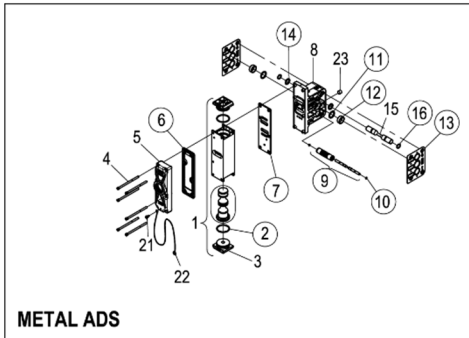
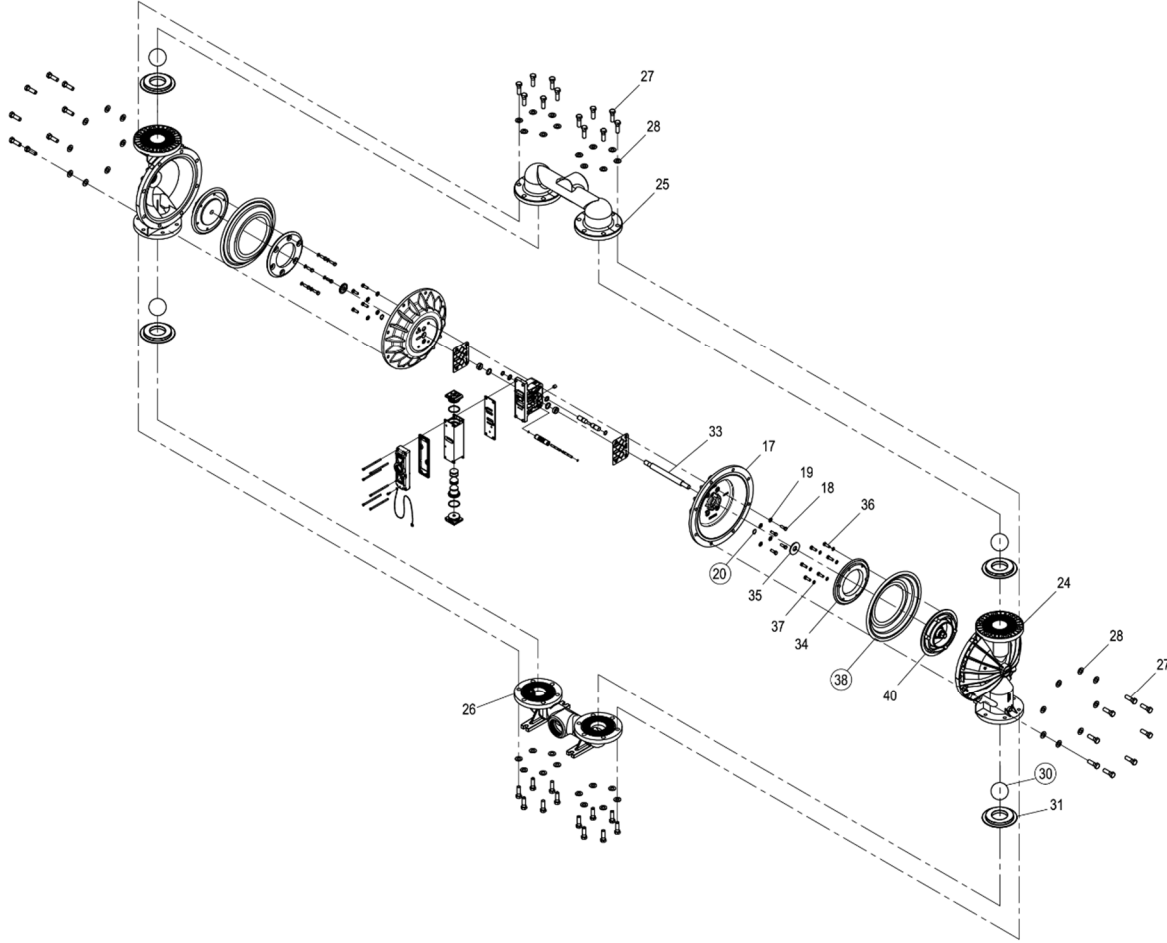

ALL CIRCLED PART IDENTIFIERS ARE INCLUDED IN REPAIR KITS

LW0305 REV. F

EXPLODED VIEW AND PARTS LIST

Item	Description	Model Description	GPS1520/AAAAA.../
		Qty.	P/N
Air Distribution Components			
1	Air Valve Assembly, Pro-Flo Shift™ 1	1	04-2039-01
2	O-Ring, End Cap (-225, Ø1.859" x Ø.139")	2	04-2390-52-700
3	End Cap	2	04-2340-01
4	Screw, SHC, Air Valve (1/4"-20 x 4-1/2")	6	01-6000-03
5	Muffler Plate, Pro-Flo Shift™	1	04-3189-01
6	Gasket, Muffler Plate, Pro-Flo Shift™	1	04-3509-52
7	Gasket, Air Valve, Pro-Flo Shift™	1	04-2638-52
8	Center Block Assembly, Pro-Flo Shift™ 2	1	15-3129-01
9	Pilot Sleeve Assembly	1	15-3884-99
10	O-Ring, Pilot Spool Retaining (-009, Ø.208" x Ø.070")	2	04-2650-49-700
11	Seal, Shaft	2	15-3210-55-225
12	Bushing, Shaft	2	15-3306-13
13	Gasket, Center Block Pro-Flo Shift™	2	04-3529-56
14	Seal, Air Control Spool	2	04-3219-49
15	Air Control Spool	1	15-3859-03
16	O-Ring, Air Control Spool Retaining (-114, Ø.612" x Ø.103")	2	04-3879-50
17	Air Chamber, Pro-Flo Shift™	2	15-3694-01
18	Screw, HHC (3/8"-16 x 1-1/8")	8	15-6130-08
19	Washer, Flat (Ø.406" x Ø.812" x .065")	8	15-6740-08-50
20	Retaining Ring	2	04-3890-03
21	Grounding Screw, (10-32 x 1/2") Self Tapping	1	04-6345-08
22	Grounding Strap, CSA	1	01-8303-99
23	Plug, Pipe, 1/4" MNPT	1	00-7010-08
Wetted Path Components			
24	Liquid Chamber, Bolted	2	15-4980-01
25	Manifold, Discharge (NPT)	1	15-5035-01
	Manifold, Discharge (BSPT)	1	15-5036-01
26	Manifold, Inlet (NPT)	1	15-5095-01
	Manifold, Inlet (BSPT)	1	15-5096-01
27	Screw, HHC (5/8"-11 x 2")	40	15-6180-08
28	Washer, Flat (Ø.656" x Ø1.312" x .095")	40	15-6732-08
Gaskets/Valve Balls/Valve Seats/Valve O-Rings			
29	Manifold Gasket, PTFE Fitted (not shown)	4	15-1405-55
30	Ball, Valve	4	15-1080-58
	Ball, Valve, PTFE Fitted	4	15-1080-55
31	Seat, Valve	4	15-1126-58
	Seat, Valve, PTFE Fitted	4	15-1125-03
32	O-Ring, Valve Seat PTFE Fitted (-250, Ø4.984" x Ø.139") (Not Shown)	4	15-1205-55
TPE/PTFE Components			
33	Shaft, Stallion	1	15-3848-03
	Shaft, PTFE Fitted	1	15-3805-03
34	Piston, Inner	2	15-3700-01
35	Washer, Inner Piston Back-up	2	15-6850-08
36	Inner Piston Screw, HHC (3/8"-16 x 1-1/8")	12	15-6130-08
37	Inner Piston Washer (Ø.406" x Ø.812" x .065")	12	15-6740-08-50
38	Diaphragm, Primary	2	15-1022-58
	Diaphragm, Primary, PTFE Fitted	2	15-1040-55-42
39	Diaphragm, Back-Up, PTFE Fitted	2	15-1065-57
40	Piston, Outer	2	15-4550-01

LW0306 REV. G

¹ Air Valve Assembly includes items 2 and 3.

² Metal Center Block Assembly includes item 11, 12, 14, 15 and 16.

All boldface items are primary wear parts.

EXPLODED VIEW AND PARTS LIST

Item	Description	Model Description	Qty.	GPS1520/1530/SSSAA/.../	GPS1520/1530/SSSS/.../
				P/N	P/N
Air Distribution Components					
1	Air Valve Assembly, Pro-Flo Shift™ 1		1	04-2039-01	04-2039-03
2	O-Ring, End Cap (-225, Ø1.859" x Ø.139")		2	04-2390-52-700	04-2390-52-700
3	End Cap		2	04-2340-01	04-2340-03
4	Screw, SHC, Air Valve (1/4"-20 x 4-1/2")		6		01-6000-03
5	Muffler Plate, Pro-Flo Shift™		1	04-3189-01	04-3189-03
6	Gasket, Muffler Plate, Pro-Flo Shift™		1		04-3509-52
7	Gasket, Air Valve, Pro-Flo Shift™		1		04-2638-52
8	Center Block Assembly, Pro-Flo Shift™ 2		1	15-3129-01	15-3129-03
9	Pilot Sleeve Assembly		1		15-3884-99
10	O-Ring, Pilot Spool Retaining (-009, Ø.208" x Ø.070")		2		04-2650-49-700
11	Seal, Shaft		2		15-3210-55-225
12	Bushing, Shaft		2		15-3306-13
13	Gasket, Center Block Pro-Flo V™		2		04-3529-56
14	Seal, Air Control Spool		2		04-3219-49
15	Air Control Spool		1		15-3859-03
16	O-Ring, Air Control Spool Retaining (-114, Ø.612" x Ø.103")		2		04-3879-50
17	Air Chamber, Pro-Flo V™		2		15-3690-03
18	Screw, HHC (3/8"-16 x 1")		8		08-6130-03
19	Washer, Flat (Ø.406" x Ø.812" x .065")		8	15-6740-08-50	04-6740-03
20	Retaining Ring		2		04-3890-03
21	Grounding Screw, (10-32 x 1/2") Self Tapping		1		04-6345-08
22	Grounding Strap, CSA		1		01-8303-99
23	Plug, Pipe, 1/4" MNPT		1	00-7010-08	00-7010-03
Wetted Path Components					
24	Liquid Chamber, Bolted		2		15-5006-03
25	Manifold, Discharge (NPT)		1		15-5035-03
	Manifold, Discharge (BSPT)		1		15-5036-03
	Manifold, Discharge (ANSI)		1		15-5045-03
	Manifold, Discharge (DIN)		1		15-5046-03
26	Manifold, Inlet (NPT)		1		15-5095-03
	Manifold, Inlet (BSPT)		1		15-5096-03
	Manifold, Inlet (ANSI)		1		15-5125-03
	Manifold, Inlet (DIN)		1		15-5126-03
27	Screw, HHC (5/8"-11 x 2")		16		15-6180-03
28	Spring, Disk (5/8")		16		15-6820-03
29	Screw, HHC (1/2"-13 x 1-1/2")		16		04-6180-03
30	Spring, Disk (1/2")		16		15-6810-03
Gaskets/Valve Balls/Valve Seats/Valve O-Rings					
31	Ball, Valve		4		15-1085-58
	Ball, Valve, PTFE Fitted		4		15-1085-55
32	Seat, Valve		4		15-1128-58
	Seat, Valve, PTFE Fitted		4		15-1129-03
33	O-Ring, Valve Seat PTFE Fitted (-358, Ø5.600" x Ø.210") (not shown)		4		15-1209-55
TPE/PTFE Components					
34	Shaft, Stallion		1		15-3848-03
	Shaft, PTFE Fitted		1		15-3805-03
35	Piston, Inner		2	15-3700-01	15-3700-03
36	Washer, Inner Piston Back-up		2		15-6850-08
37	Screw, HHC (3/8"-16 x 1-1/8")		12	15-6130-08	
	Screw, HHC (3/8"-16 x 1")		12		08-6130-03
38	Washer (Ø.406" x Ø.812" x .065")		12	15-6740-08-50	04-6740-03
39	Diaphragm, Primary		2		15-1022-58
	Diaphragm, Primary, PTFE Fitted		2		15-1040-55-42
40	Diaphragm, Back-Up, PTFE Fitted		2		15-1065-57
41	Piston, Outer		2		15-4550-03

LW0308 REV. G

¹ Air Valve Assembly includes items 2 and 3.

² Metal Center Block Assembly includes item 11, 12 and 14.

All boldface items are primary wear parts.

NOTES

NOTES

WILDEN®

PSG
22069 Van Buren Street
Grand Terrace, CA 92313-5651 USA
P: +1 (909) 422 -1730
psgdover.com



Where Innovation Flows

PSG® reserves the right to modify the information and illustrations contained in this document without prior notice. This is a non-contractual document.