

EXPLODED VIEW & PARTS LISTING

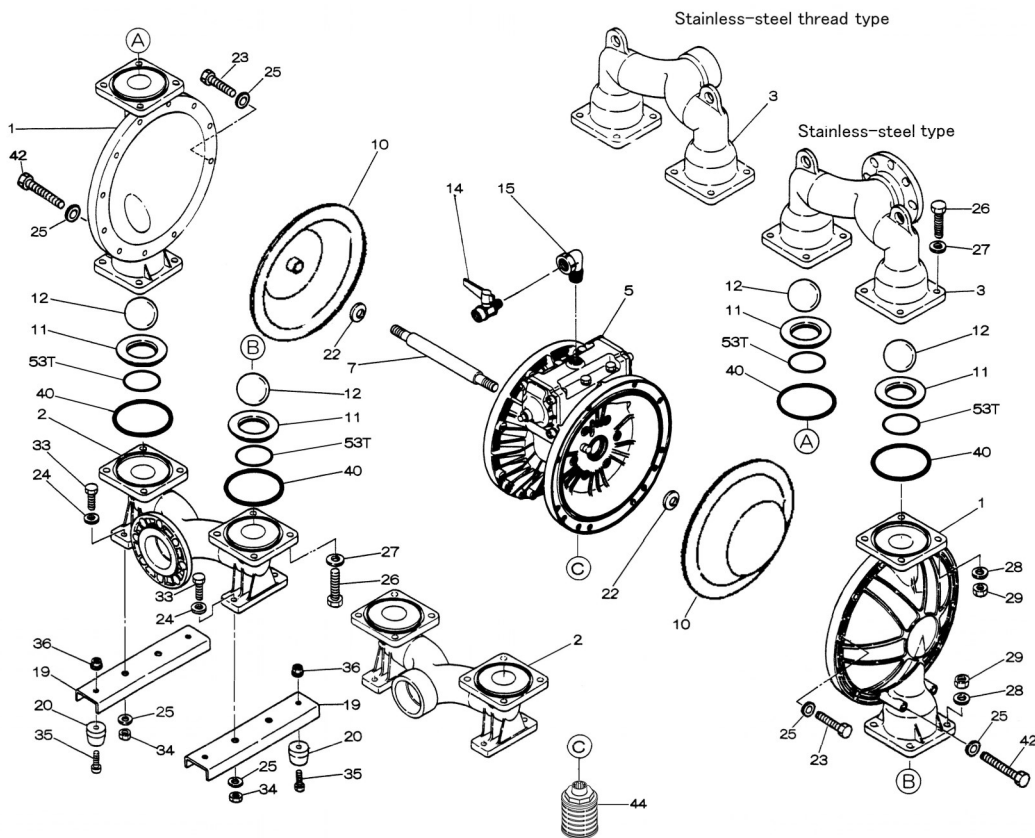

Air Operated Double Diaphragm Pump

Model: NDP-80BSU  
 Model #: 852651-U (NPT)  
 Model #: 852243-U (FLG)

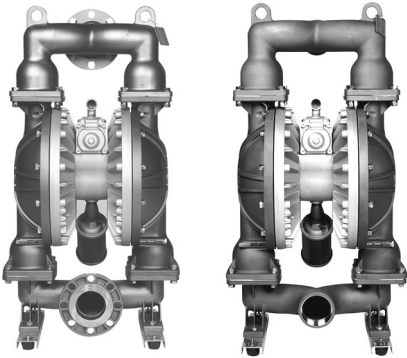

■ Body Assembly

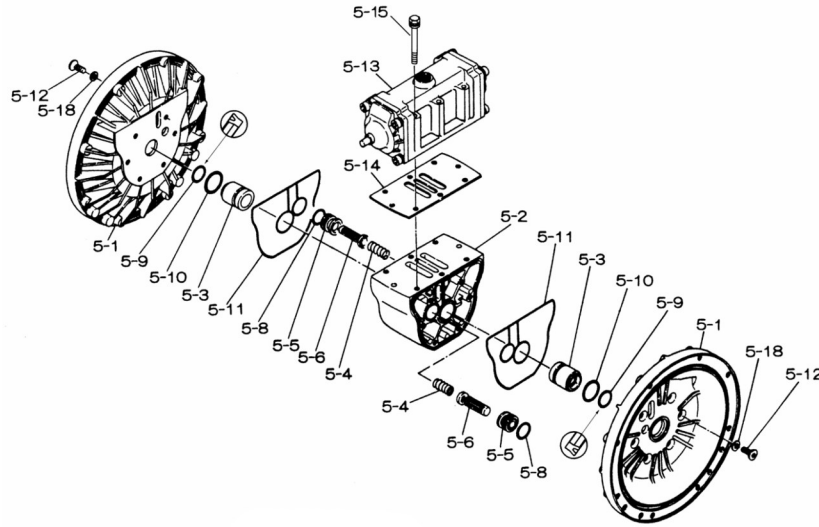

■ Valve Body Assembly

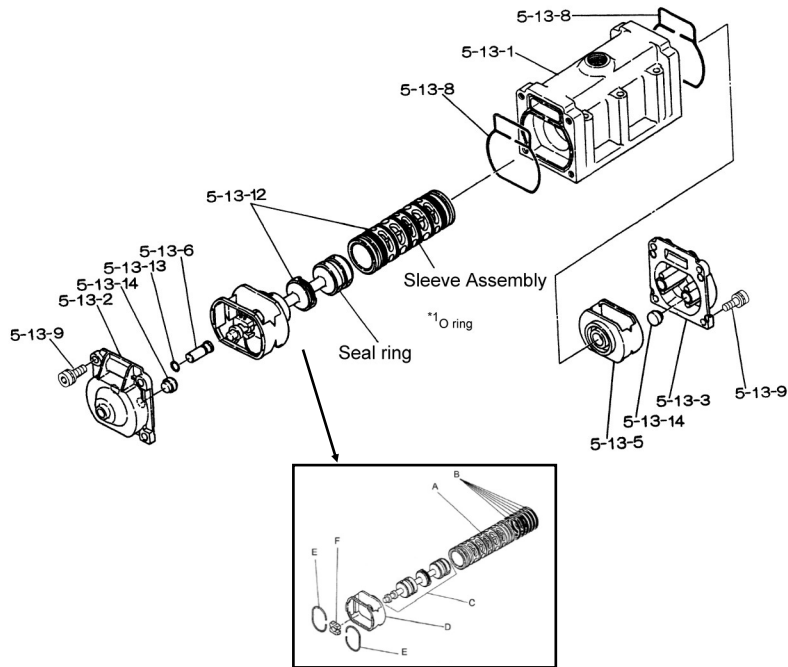

Air Operated Double Diaphragm Pump

NPT	852651-U			
FLG	852243-U			
REF. NO.	PART NO.	DESCRIPTION	QTY.	REORDER
1	712933	OUT CHAMBER	2	
2	712605	IN MANIFOLD (NPT)	1	
2	712603	IN MANIFOLD (FLG)	1	
3	712604	OUT MANIFOLD (NPT)	1	
3	712602	OUT MANIFOLD (FLG)	1	
<b>5</b>	<b>803113</b>	<b>CENTER BODY ASSY</b>	<b>1</b>	
5-1	711935	AIR CHAMBER	2	
5-2	711936	BODY	1	
5-3	772689	THROAT BEARING	2	
5-4	711937	PILOT VALVE SPRING	2	
5-5	771740	PILOT VALVE SEAT	2	
5-6	832163	PILOT VALVE ASSY	2	
5-8	640020	O RING	2	
5-9	685444	V PACKING	2	
5-10	640029	O RING	2	
5-11	771742	GASKET	2	
5-12	683812	FLAT SOCKET	12	
5-13	802971	VALVE BODY ASSY.	1	
5-13-1	711931	VALVE BODY	1	
5-13-2	580999	CAP A	1	
5-13-3	581000	CAP B	1	
5-13-5	771735	SPRING RETAINER	1	
5-13-6	712976	RESET BUTTON	1	
5-13-8	771738	GASKET	2	
5-13-9	685036	SOCKET BOLT	8	
5-13-12	805084	C SPOOL ASSY	1	
A	803675	SLEEVE ASSY	1	
B	640036	O RING	6	
C	805085	SPOOL ASSY	1	
D	771735	SPRING RETAINER	1	
E	711932	C-SPRING	2	
F	771734	BLOCK	1	
5-13-13	640005	O RING	1	
5-13-14	684128	CUSHION	4	
5-14	771712	GASKET	1	
5-15	684240	BOLT W/WASHERS	6	
5-18	684987	WASHER	12	
7	717131	CENTER ROD	1	
10	833231	DIAPHRAGM	2	
11	711910	VALVE SEAT	4	
12	770694	BALL	4	
14	686974	BALL VALVE	1	
15	682523	ELBOW	1	
19	711912	BASE	2	
20	771402	FOOT RUBBER	4	
22	682740	WASHER	2	
23	621182	BOLT	20	
23	631937	WAVE WASHER	20	

NPT	852651-U			
FLG	852243-U			
REF. NO.	PART NO.	DESCRIPTION	QTY.	REORDER
24	631174	FLAT WASHER	4	
25	631937	WAVE WASHER	4	
26	621203	BOLT	16	
27	631175	FLAT WASHER	16	
28	631938	WAVE WASHER	16	
29	628014	NUT	16	
33	621177	BOLT	4	
34	628013	NUT	4	
35	611149	BOLT	4	
36	682276	NUT W/FLANGE	4	
40	643078	O RING	4	
42	683543	BOLT	4	
53	631937	WAVE WASHER	4	
44	804764	SILENCER ASSY.	1	
53T	643145	O RING	4	
KIT	K80-MU	LIQUID SIDE KIT		
KIT	K80-AM	AIR MOTOR KIT		

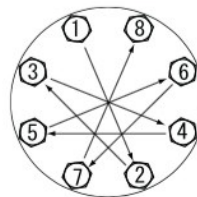

**Tightening torque for out chambers.**  
 Out Chambers 29 ft-lbf {40 N-m}

**Tightening torque for manifold retainer bolts.**  
 BSU 18 ft-lbf {25 N-m}

**General Tools:**

- Socket wrenches - 24mm
- Hexagonal box wrench - 5mm, 6mm
- Open-end wrenches - 19mm, 24mm
- Plastic hammer

**Special Tools:**

- Sleeve remover (713180) sold separately

**Miscellaneous:**

- Assembly Oil - turbine oil class 1 (equivalent to ISO VG32 grade)
- Thread locker
- Urea grease grade (NLGI) No. 2

**Customer Notes**

Model #: \_\_\_\_\_  
 Description: \_\_\_\_\_  
 Serial #: \_\_\_\_\_  
 Date Installed: \_\_\_\_\_  
 Department Location: \_\_\_\_\_  
 Tag/Project: \_\_\_\_\_