

# **BALDOR**® • **RELIANCE**

## **Product Information Packet**

# **CL5031T**

**2HP,3450RPM,1PH,60HZ,143TC,X3535L,XPFC**

Part Detail							
Revision:	AW	Status:	PRD/A	Change #:		Proprietary:	No
Type:	AC	Prod. Type:	3535L	Elec. Spec:	35WG0506	CD Diagram:	CD0001
Enclosure:	XPFC	Mfg Plant:		Mech. Spec:	35L966	Layout:	35LYL966
Frame:	143TC	Mounting:	F1	Poles:	02	Created Date:	06-27-2007
Base:	RG	Rotation:	R	Insulation:	B	Eff. Date:	06-29-2016
Leads:	4#14 A PH,2#18 B PH					Replaced By:	
Literature:		Elec. Diagram:					

Nameplate NP1426XPSL				
NO.	<input type="text"/>	CC	<input type="text"/>	
SER.	<input type="text"/>			
SPEC.	35L966-506			
CAT.NO.	CL5031T			
HP	2	T. CODE	T3C	
VOLTS	115/208-230			
AMPS	23/12-11.5			
RPM	3450			
HZ	60	PH	1	
SER.F.	1.00	DES	L	
RATING	40C AMB-CONT		CL	B
FRAME	143TC	NEMA-NOM-EFF		74
USABLE AT 208V	12	PF	82	
BLANK	<input type="text"/>			

Parts List		
Part Number	Description	Quantity
SA027461	SA 35L966-506	1.000 EA
RA023509	RA 35L966-506	1.000 EA
EC1324A02	ELEC CAP, 324-389 MFD, 125V, 1.48D X 3.	2.000 EA
MJ5000A09	EFI KIT #1578 (400 ML CARTRIDGE OF EFI	0.050 EA
35CB3001A02SP	EXPL PROOF CONDUIT BOX, 3/4"PIPE TAP LEA	1.000 EA
11XW1032G06	10-32 X .38, TAPTITE II, HEX WSHR SLTD U	1.000 EA
HW3001B01	BRASS CUP WASHER, FOR #8 SCREW	1.000 EA
35EP3700A01SP	FR ENDPLATE, XPFC	1.000 EA
51XW0832A07	8-32 X .44, TAPTITE II, HEX WSHR SLTD SE	2.000 EA
WD1000A03	41531 AMP FLG.TERM,4M/REEL(2.5MIL)	8.000 EA
WD1000A04	1-480307-1AMP REC(200/PKG)ACC#081693-10-	8.000 EA
HA6003A52	CLAMP, CAPACITOR, WHITE ZINC PLATED	2.000 EA
51XW0832A07	8-32 X .44, TAPTITE II, HEX WSHR SLTD SE	2.000 EA
HW5100A03SP	WAVY WASHER (W1543-017)	1.000 EA
35EP3702A01SP	PU EP-205 BRG-35X-56C-143-5TC	1.000 EA
51XN1032A18	10-32 X 1 1/8 HX WS SL SR (ESKAY)	2.000 EA
HW3021C06	3/32 DI X .625 PIN (F/S)	2.000 EA
HA3013A01	1/2-20X5/8 SPL.HX BOLT	2.000 EA
XY3118A12	5/16-18 HEX NUT DIRECTIONAL SERRATION	4.000 EA
MG1025G29	WILKOFASST, 789.229, DARK CHARCOAL GRAY	0.014 GA
51XB1214A16	12-14X1.00 HXWSSLD SERTYB	1.000 EA
51XW1032A06	10-32 X .38, TAPTITE II, HEX WSHR SLTD S	3.000 EA
35CB3500A01SP	CONDUIT BOX LID, MACH	1.000 EA
51XN2520A16	SCREW, HEX WS SLT, ZN, 1/4-20 X 1.00	4.000 EA

<b>Parts List (continued)</b>		
<b>Part Number</b>	<b>Description</b>	<b>Quantity</b>
HW2501D13	KEY, 3/16 SQ X 1.375	1.000 EA
HA7000A01	KEY RETAINER 7/8" DIA SHAFT	1.000 EA
85XU0407S04	4X1/4 U DRIVE PIN STAINLESS	6.000 EA
NP0018W	ALUM UL XP CONDUIT BOX NAMEPLATE	1.000 EA
MJ1000A02	GREASE, POLYREX EM EXXON (USe 4824-15A)	0.050 LB
34FN3002A01SP	EXTERNAL FAN, PLASTIC, .637/.639 HUB W/	1.000 EA
35FH4005A01SP	IEC FH NO GREASER W/PRIMED	1.000 EA
HA3104A10	THRUBOLT, 5/16-18 X 10.25	4.000 EA
SP5055A11	MODEL 35 TYPE L STATIONARY SWITCH WITH L	1.000 EA
LB1119N	WARNING LABEL	1.000 EA
LC0081	CONNECTION LABEL X	1.000 EA
NP1426XPSL	SS XP UL CSA CC CL-I GP-D CL-II GP-F&G	1.000 EA
36PA1000	PKG GRP, PRINT PK1016A06	1.000 EA

**AC Induction Motor Performance Data**

Record # 20313 - Typical performance - not guaranteed values

<b>Winding:</b> 35WG0506-R005	<b>Type:</b> 3535L	<b>Enclosure:</b> XPFC
-------------------------------	--------------------	------------------------

Nameplate Data				230 V, 60 Hz: High Voltage Connection	
Rated Output (HP)	2			Full Load Torque	3 LB-FT
Volts	115/208-230			Start Configuration	direct on line
Full Load Amps	23/12-11.5			Breakdown Torque	9 LB-FT
R.P.M.	3450			Pull-up Torque	6 LB-FT
Hz	60	Phase	1	Locked-rotor Torque	7.5 LB-FT
NEMA Design Code	L	KVA Code	K	Starting Current	78 A
Service Factor (S.F.)	1			No-load Current	6 A
NEMA Nom. Eff.	74	Power Factor	82	Line-line Res. @ 25°C	0.864 Ω A Ph 1.26 Ω B Ph
Rating - Duty	40C AMB-CONT			Temp. Rise @ Rated Load	78°C

Load Characteristics 230 V, 60 Hz, 2 HP

% of Rated Load	25	50	75	100	125	150
Power Factor	50	65	75	81	85	87
Efficiency	49.1	64.2	70.5	73.4	74.3	74.1
Speed	3569	3548	3524	3499	3471	3438
Line amperes	6.65	7.75	9.2	10.9	12.9	15.1

Performance Graph at 230V, 60Hz, 2.0HP Typical performance - Not guaranteed values

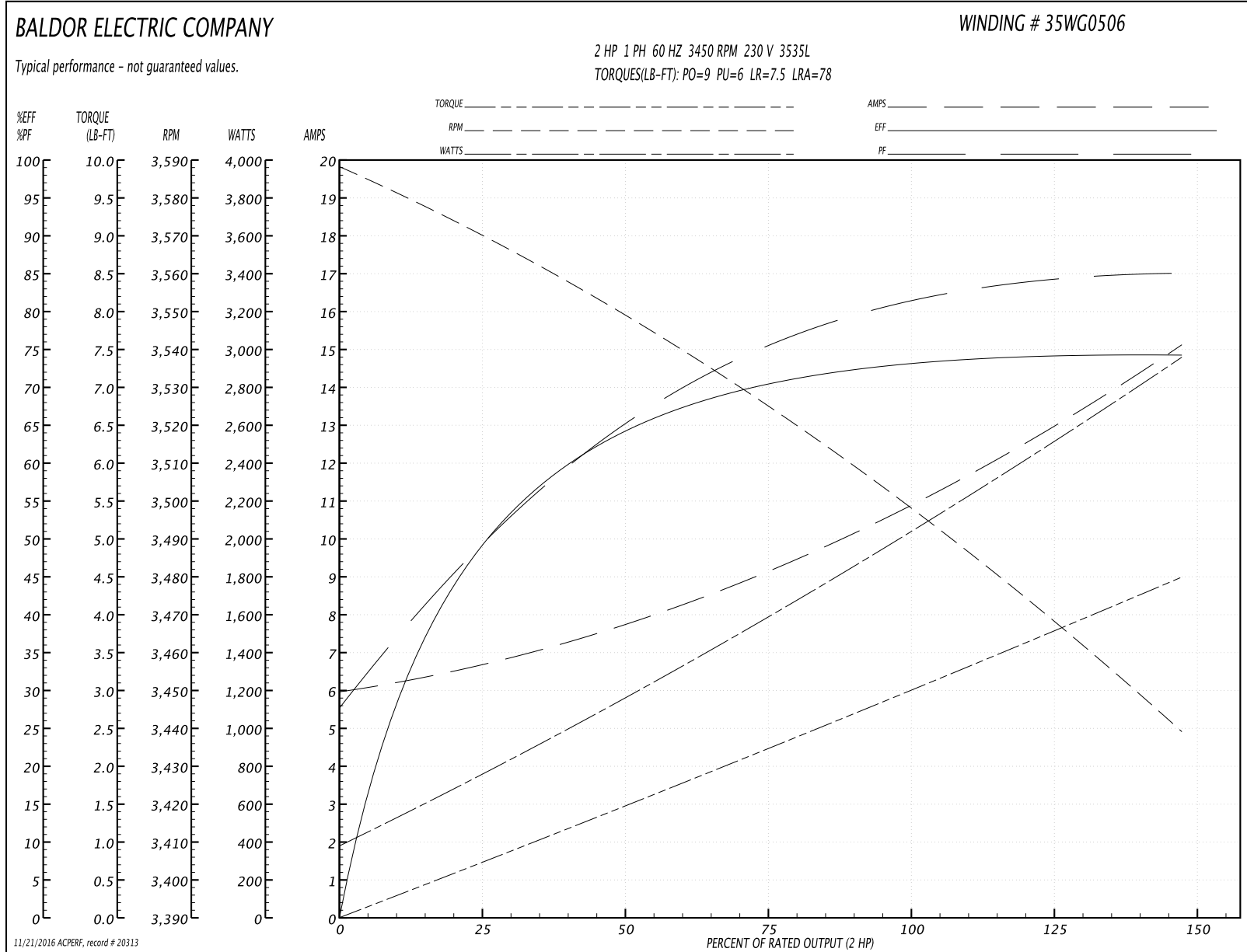

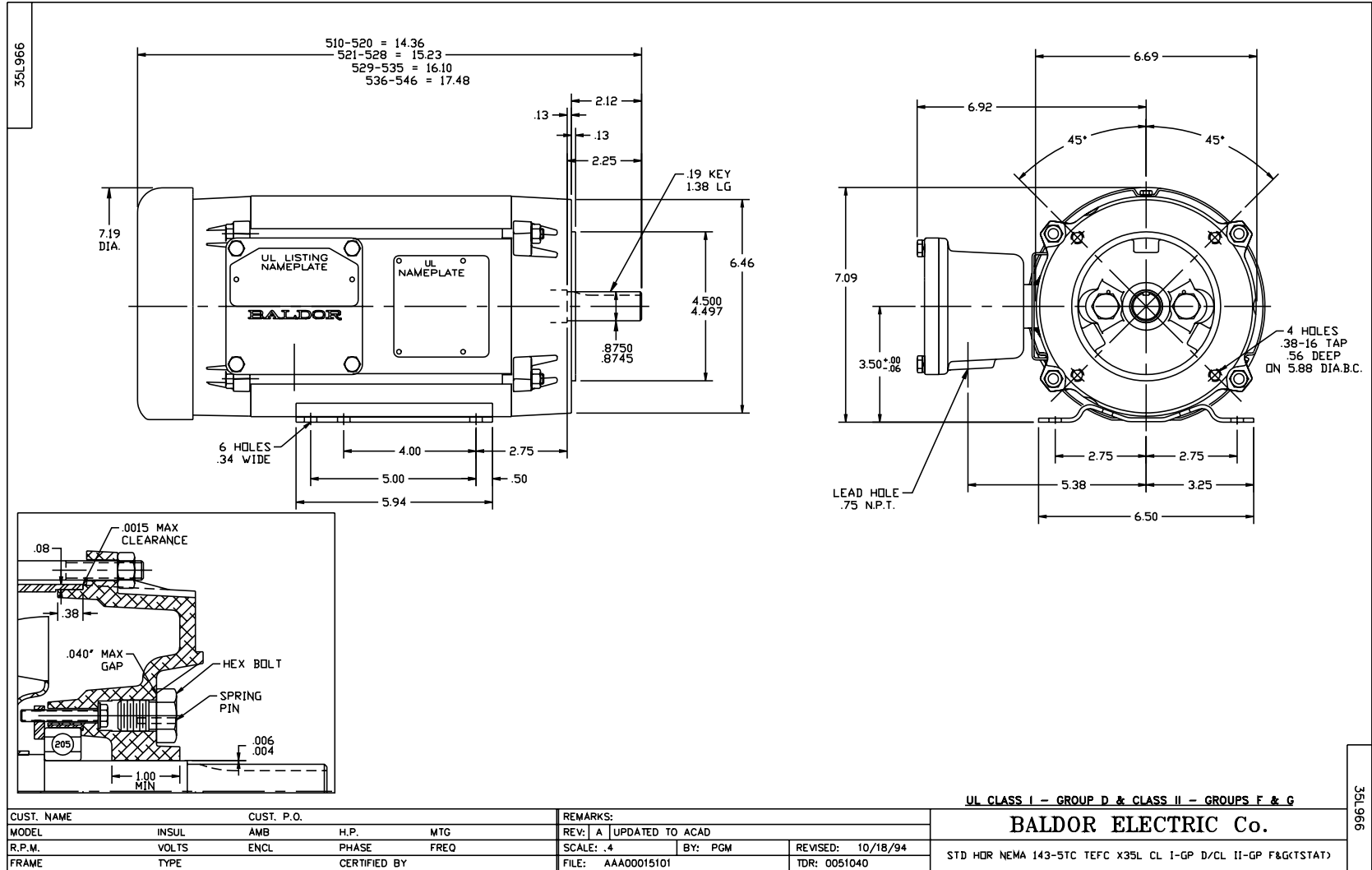

CD0001



CD0001

REV. DESC: REVISE TO SHOW OPTIONAL COLORS			
REV. LTR: D	BY: JLP	REVISED: 04/08/99 1:16	TDR: 0178636
100000		FILE: AAA00007405	MDL: -
		MTL: -	

**BALDOR ELECTRIC Co.**

TYPE L, DV, REV, 6 LEADS