

BALDOR® • ***RELIANCE***

Product Information Packet

ECP83770T-5

7.5HP, 1765RPM, 3PH, 60HZ, 213T, 0737M, TEFC, F

Part Detail							
Revision:	Z	Status:	PRD/A	Change #:		Proprietary:	No
Type:	AC	Prod. Type:	0737M	Elec. Spec:	07WGX614	CD Diagram:	CD0006
Enclosure:	TEFC	Mfg Plant:		Mech. Spec:	07K629	Layout:	07LYK629
Frame:	213T	Mounting:	F1	Poles:	04	Created Date:	07-13-2006
Base:	RG	Rotation:	R	Insulation:	F	Eff. Date:	01-27-2016
Leads:	3#14					Replaced By:	
Literature:		Elec. Diagram:					

Nameplate NP3235E			
CAT.NO.	ECP83770T-5		
SPEC.	07K629X614		
HP	7.5 TE		IP 56
VOLTS	575		
AMP	7.6		
RPM	1765		
FRAME	213T	HZ	60
SER.F.	1.15	CODE H	DES B
RATING	40C AMB-CONT		
SN			
DE	6307	ODE	6307
NEMA-NOM-EFF	91.7	PF	81
G.MIN.EFF	90.2	CC	010A
T. CODE	T3C	T=	160
		PH	3
		CL	F

Nameplate NP3186E			
SPEC.	07K629X614		
D.E. BRG.	35BC03X30X		
O.D.E. BRG.	35BC03X30X		
GREASE	POLYREX EM		
WEIGHT	199	# OF ROTOR BARS	28
RPM MAX	2700	MAX. KVAR	1.46
BLANK			
INV. TYPE	PWM	# OF STATOR SLOTS	36
T=	160	C HP TO	90
C HP FR	60	CT HZ TO	60
CT HZ FROM	1.2	VT HZ TO	60
VT HZ FROM	0-	HTR-AMPS	N/A
HTR-VOLTS	N/A	MAX. SPACE HEATER TEMP.	N/A
HTR-WATTS			

Parts List		
Part Number	Description	Quantity
SA145842	SA 07K629X614	1.000 EA
RA134961	RA 07K629X614	1.000 EA
37FN3002C01	EXFN, PLASTIC, 6.00 OD, 1.155 ID	1.000 EA
HW3201A05	3/8-16 EYEBOLT	1.000 EA
09CB1002A05G	CONDUIT BOX, 1.00 N.P.T. (GRAY)	1.000 EA
RM1017	LEAD SEPERATOR GASKET MODEL 307 1/8" THK	1.000 EA
51XW2520A12	.25-20 X .75, TAPTITE II, HEX WSHR SLTD	2.000 EA
HW1001A25	LOCKWASHER 1/4, ZINC PLT .493 OD, .255 I	2.000 EA
11XW1032G06	10-32 X .38, TAPTITE II, HEX WSHR SLTD U	1.000 EA
HW3001B01	BRASS CUP WASHER, FOR #8 SCREW	1.000 EA
10XN2520S06	1/4 20X3/8 HX HD CAP S.S.	2.000 EA
WD1000B16	T&B CX70TN TERMINAL	2.000 EA
07EP1119A02G	206 BRG,C.I.FH,GRSR,RLF,DRAIN FITTING,IN	1.000 EA
HW4601B25	INPRO SEAL, 307 BRG, MINI66	1.000 EA
10XN2520A26	1/4-20X 1 5/8 HEX HD	4.000 EA
XY3118A12	5/16-18 HEX NUT DIRECTIONAL SERRATION	4.000 EA
HW4500A32	FIT./EXT 1698-B (ALEMITE)GREASE FITTING	1.000 EA
HA4051A00	PLASTIC CAP FOR GREASE FITTING	1.000 EA
HW4500A17	317400 ALEMITE GREASE RELIEF	1.000 EA
HA4010A01	DRAIN PLUG,416 S.S.,W/ 1/4-28 THD & .076	1.000 EA
10XN2520A26	1/4-20X 1 5/8 HEX HD	4.000 EA
HW5100A08	W3118-035 WVY WSHR (WB)	1.000 EA
07EP1119A01G	307 BRG,BRG RET,GRSR,RLF,DRAIN FITTING,I	1.000 EA
HW4601B25	INPRO SEAL, 307 BRG, MINI66	1.000 EA

Parts List (continued)		
Part Number	Description	Quantity
HW4500A01	1641B(ALEMITE)400 UNIV, GREASE FITT	1.000 EA
HA4051A00	PLASTIC CAP FOR GREASE FITTING	1.000 EA
HW4500A17	317400 ALEMITE GREASE RELIEF	1.000 EA
HA4010A01	DRAIN PLUG,416 S.S.,W/ 1/4-28 THD & .076	1.000 EA
07FH1001A01G	SPL FAN HOUSING, 307, W/GREASER, GRAY EP	1.000 EA
10XN2520A28	1/4-20X 1 3/4 HEX HD	3.000 EA
WD4100A02	DP-1000 HEYCO PLUG OR 62MP1000 MICRO PL	1.000 EA
12CB1503A03G	CONDUIT BOX LID, MACH (GRAY), WITH LIP	1.000 EA
09GS1013A01	09 GS FOR 09CB3501 LID - BLACK NEOPRENE	1.000 EA
10XN2520A12	O1/4-20X 3/4 HEX HEAD CAP	2.000 EA
MJ5004A59	ADHESIVE LOCTITE #401 SURFACE INSENSITIV	0.010 EA
HW2501F21	KEY, 5/16 SQ X 2.375	1.000 EA
HA7000A02	KEY RETAINER RING, 1 1/8 DIA, 1 3/8 DIA	1.000 EA
MJ5001A27	32220KN GRAY SEALER *MIN BUY 4 QTS=1GAL	0.001 QT
MJ1000A73	INPRO P-80 ASSEMBLY LUB./ 1 QT. CONTAIN	0.001 QT
85XU0407S04	4X1/4 U DRIVE PIN STAINLESS	4.000 EA
LB1115N	LABEL,LIFTING DEVICE (ON ROLLS)	1.000 EA
LT0019A00	MOTOR NO-LOAD PERFORMANCE DATA SHEET	1.000 EA
WD1000D21	TRM,T&B #B71M,RING,18-14,.25,NON-INSL	3.000 EA
MJ1000A02	GREASE, POLYREX EM EXXON (USe 4824-15A)	0.050 LB
HA3104A32	THRUBOLT- 5/16-18 X12.750	4.000 EA
51XB1214A20	12-14X1.25 HXWSSLD SERTYB	1.000 EA
MG1025N19	WILKOFASST, 778.50, RELIANCE BLUE-GREEN	0.036 GA
LB1119N	WARNING LABEL	1.000 EA

LC0006	CONNECTION LABEL	1.000 EA
LB1449	DIV-2/NEC WARNING LABEL	1.000 EA
NP3235E	SS IEEE841 DIV-2 UL CSA-C US EEV PREM	1.000 EA
NP3186E	SS IEEE841 INV AUX DATA INFORMATION	1.000 EA
07PA1011	PKG GRP, 07 CAST IRON PK1181	1.000 EA
10XL3808A28	3/8 X 1 3/4" LAG SCREW	2.000 EA
MN416A01	TAG-INSTAL-MAINT no wire (1000/bx) 11/14	1.000 EA

AC Induction Motor Performance Data

Record # 47344 - Typical performance - not guaranteed values

Winding: 07WGX614-R013	Type: 0737M	Enclosure: TEFC
-------------------------------	--------------------	------------------------

Nameplate Data				575 V, 60 Hz: Single Voltage Motor	
Rated Output (HP)	7.5			Full Load Torque	22.2 LB-FT
Volts	575			Start Configuration	direct on line
Full Load Amps	7.6			Breakdown Torque	62.1 LB-FT
R.P.M.	1765			Pull-up Torque	33.9 LB-FT
Hz	60	Phase	3	Locked-rotor Torque	41.3 LB-FT
NEMA Design Code	B	KVA Code	H	Starting Current	50.7 A
Service Factor (S.F.)	1.15			No-load Current	3.07 A
NEMA Nom. Eff.	91.7	Power Factor	81	Line-line Res. @ 25°C	2.31 Ω
Rating - Duty	40C AMB-CONT			Temp. Rise @ Rated Load	47°C
S.F. Amps				Temp. Rise @ S.F. Load	58°C
				Locked-rotor Power Factor	37
				Rotor inertia	0.91 LB-FT ²

Load Characteristics 575 V, 60 Hz, 7.5 HP

% of Rated Load	25	50	75	100	125	150	S.F.
Power Factor	45	67	76	80	82	83	81
Efficiency	88.3	91.6	91.9	91.9	91	89	91.4
Speed	1791	1783	1774	1765	1754	1742	1758
Line amperes	3.52	4.55	5.91	7.58	9.42	11.4	8.68

Performance Graph at 575V, 60Hz, 7.5HP Typical performance - Not guaranteed values

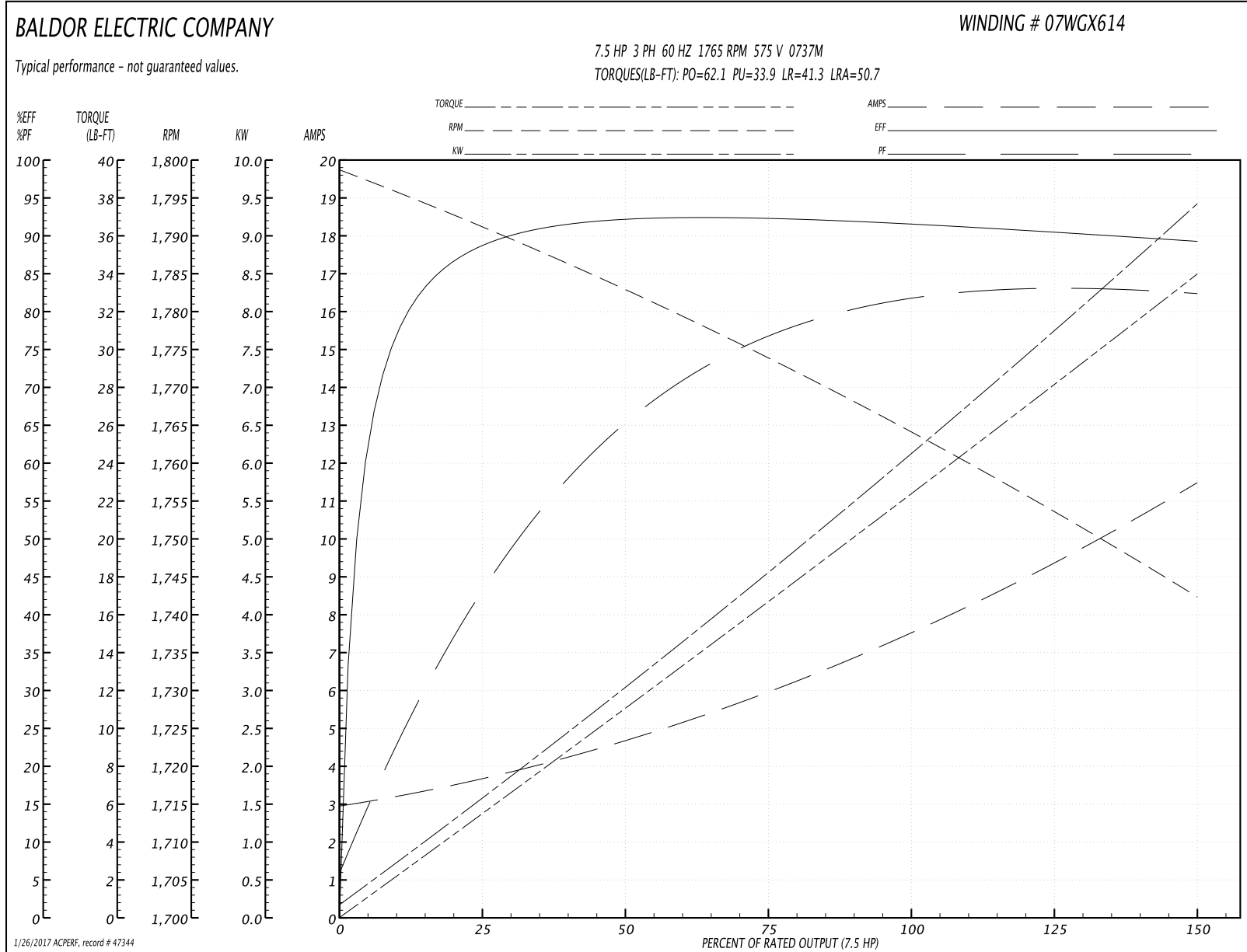

07LYK629

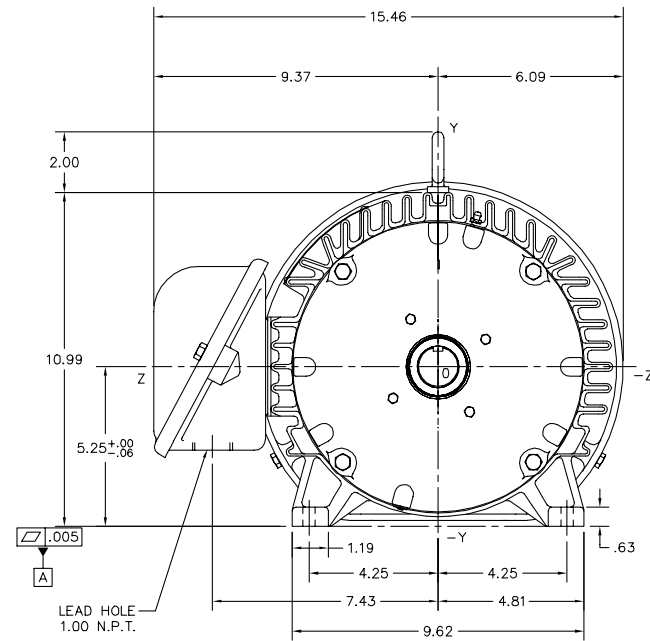
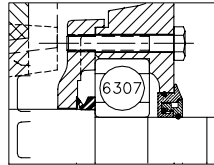
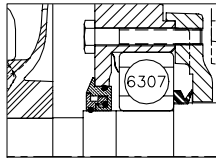
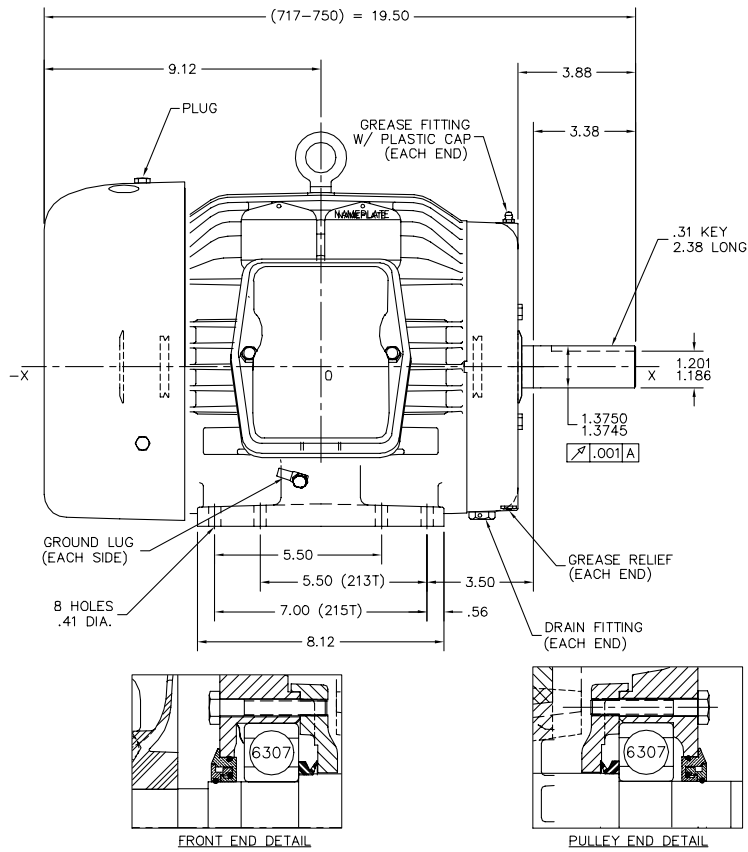

SPEC	MOTOR WEIGHT	C.O.G. FROM CENTERLINE
07K629X813G32	231 LBS	X=.01, Y=.48, Z=.24

CUSTOMER IS RESPONSIBLE FOR DETERMINING THAT BALDOR'S PRODUCT WILL PERFORM SUITABLY IN THE INTENDED APPLICATION.

REV. DESC: ADD X, Y, Z & 0,0,0	VERSION: 07	TDR: 000000996213
REV. LTR: G	REVISD: 03:23:06 09/08/2016	BY: ENALEMO
FILE: \AAA\00118\406		
MTL: -		

BALDOR

STD HORZ 213-5T TEFC 07M (ECP) IEEEB41
SH 1 of 1

07LYK629

CD0006



NOTES:

1. THREE LEAD MOTOR MAY BE EITHER WYE CONNECTED OR DELTA CONNECTED.
2. INTERCHANGE ANY TWO LINE LEADS TO REVERSE ROTATION.
3. OPTIONAL THERMOSTATS ARE PROVIDED WHEN SPECIFIED.
4. ACTUAL NUMBER OF INTERNAL PARALLEL CIRCUITS MAY VARY.
5. LEAD COLORS ARE OPTIONAL. LEADS MUST BE NUMBERED AS SHOWN.

REV. DESC: REVISE TO SHOW OPTIONAL COLORS			
REV. LTR: D	BY: JLP	REVISED: 01/21/99 4:02	TDR: 0171435
9000D		FILE: AAA00005141	MDL: -
		MTL: -	

BALDOR ELECTRIC Co.

3PH, SV, 3 LEADS, WYE OR DELTA CONNECTED

CD0006