

**BERKELEY®**

## **MODELS**

**Medium Head – Noryl® Impellers**

**Medium Head – Brass Impellers**

**High Head – Noryl® Impellers**

**High Head – Brass Impellers**

**1/3 H.P.: 115 Volt Single Phase**

**1/2 through 2-1/2 H.P.:**

**115/230 Volt Single Phase**

**230 Volt Single Phase**

**230/460 Volt Three Phase**

**575 Volt Three Phase**

NORYL® IS A REGISTERED TRADEMARK OF THE GENERAL ELECTRIC COMPANY  
BERKELEY® IS A REGISTERED TRADEMARK OF PENTAIR LTD.

293 WRIGHT STREET, DELAVAN, WI 53115 WWW.BERKELEYPUMPS.COM  
PH: 888-782-7483

© 2013 Pentair, Ltd. All Rights Reserved.

BE873T (Rev. 02/22/13)



## PIPING - GENERAL

Support both suction and discharge piping independently at a point near the pump to avoid putting a strain on the pump housing. Start all piping **AT THE PUMP**.

Increase pipe diameter at both the suction and discharge by one (1) standard pipe size (minimum) to obtain desired performance and flow rate. Refer to Table I when sizing pipe for your pumping system.

**NOTICE:** Do not use pipe with **smaller** diameter on the suction side of pump.

**TABLE I**

Pump Port Size (NPT)		Recommended Pipe Size	
Suction	Discharge	Suction	Discharge
1-1/4	1	1-1/2	1-1/4
1-1/2	1-1/4	2	1-1/2
2	1-1/2	3	2

## SUCTION PIPE

Increase pipe size from pump suction port as shown in Table I.

Figure 1 (Page 2) depicts a recommended run of pipe and fittings for the suction side of a centrifugal pump. Please refer to this illustration when choosing pipe and fittings for your suction connection.

**IMPORTANT:** All connections must be air tight!

Figure 2 (Page 2) depicts conditions that are **NOT DESIRABLE** on the suction side of a centrifugal pump and may cause problems in flow rate and priming. Please look this illustration over carefully before choosing pipe and fittings for your suction connection.

## DISCHARGE PIPING

Increase pipe size from pump discharge port as shown in Table I. Figure 1 (Page 2) depicts a recommended run of pipe and fittings for the discharge. Install tee with priming plug as close to pump as possible. Figure 2 (Page 2) notes conditions that should be avoided. Please read over carefully before making discharge connection.

## PRIMING THE PUMP

A pump is primed when all air in the suction line and pump volute has been evacuated and replaced with water.

**To Prime:**

1. Close valve in discharge line.
2. Remove priming plug from tee and fill pump and suction line with water until water is flowing back out of tee.
3. Replace priming plug.
4. Start pump and slowly open valve until desired water flow is achieved.

**NOTICE:** If water is not being pumped, turn off pump, close valve, and repeat steps 1 thru 4.

If pump volute is rotated as shown in Figure 1 (Page 2), loosen vent plug when priming to evacuate air trapped inside volute and tighten when volute is completely filled with water.

**NOTICE:** Do not run the pump dry. This will damage mechanical seal and void warranty.

**CAUTION** Burn hazard. Motor normally operates at high temperature and will be too hot to touch. It is protected from heat damage during operation by an automatic internal cutoff switch. Before handling pump or motor, stop motor and allow it to cool for 20 minutes.

**TABLE II - RECOMMENDED FUSING AND WIRING DATA – 60 CYCLE TEFC MOTORS**

MOTOR HP	MAX. LOAD AMPERES	BRANCH FUSE* RATING AMPS	DIAMETER IN FEET FROM MOTOR TO METER				
			0' TO 100'	101' TO 200'	201' TO 300'	301' TO 400'	401' TO 500'
			WIRE SIZE				
<b>SINGLE PHASE - 115 VOLT</b>							
1/2	8.2/4.1	15/15	14/14	12/14	10/14	8/14	8/12
3/4	11.6/5.8	20/15	14/14	10/14	8/14	6/14	6/12
1	18.0/9.0	30/15	10/14	8/14	6/12	6/12	4/10
1-1/2	18.0/9.0	30/15	10/14	8/14	6/12	6/12	4/10
<b>SINGLE PHASE - 230 VOLT</b>							
2	10.4	15	14	14	12	10	10
2-1/2	11.7	15	14	14	12	10	10
<b>THREE PHASE - 230/460 VOLT</b>							
1/2	2.2/1.1	15/15	14/14	14/14	14/14	14/14	14/14
3/4	2.9/1.45	15/15	14/14	14/14	14/14	14/14	14/14
1	3.6/1.8	15/15	14/14	14/14	14/14	14/14	14/14
1-1/2	4.8/2.4	15/15	14/14	14/14	14/14	14/14	14/14
2	7.0/3.5	15/15	14/14	14/14	14/14	12/14	12/14
2-1/2	7.0/3.5	15/15	14/14	14/14	14/14	12/14	12/14
<b>THREE PHASE - 575 VOLT</b>							
1/2	1.16	15	14	14	14	14	14
3/4	1.44	15	14	14	14	14	14
1	1.92	15	14	14	14	14	14
1-1/2	2.4	15	14	14	14	14	14
2	2.92	15	14	14	14	14	14
2-1/2		15	14	14	14	14	14

\* Time delay fuse or circuit breakers are recommended in any motor circuit.

# ELECTRICAL

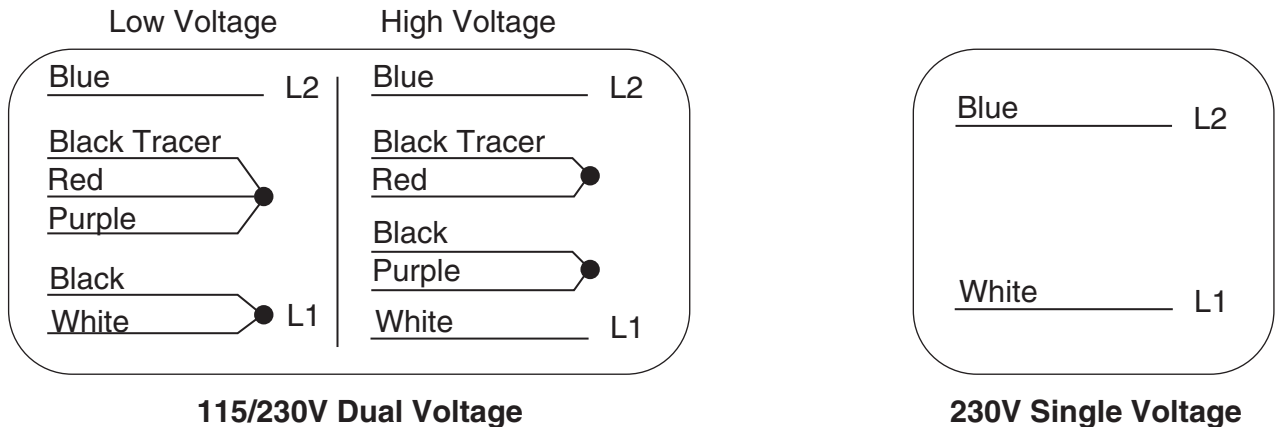

**Figure 3 – 115/230V Dual Voltage and 230V Single Voltage TEFC Wiring Diagram**

**⚠ WARNING Hazardous voltage.** Can shock, burn, or cause death. Disconnect power to motor before working on pump or motor. Ground motor before connecting to power supply.

**California Proposition 65 Warning**

**⚠ WARNING** This product and related accessories contain chemicals known to the State of California to cause cancer, birth defects or other reproductive harm.

**WIRING**

**⚠ Ground motor before connecting to electrical power supply. Failure to ground motor can cause severe or fatal electrical shock hazard.**

**⚠ Do not ground to a gas supply line.**

**⚠ To avoid dangerous or fatal electrical shock, turn OFF power to motor before working on electrical connections.**

**⚠ Supply voltage must be within ±10% of nameplate voltage. Incorrect voltage can cause fire or damage motor and voids warranty. If in doubt consult a licensed electrician.**

**⚠ Use wire size specified in Wiring Chart (Page 3). If possible, connect pump to a separate branch circuit with no other appliances on it.**

**⚠ Wire motor according to diagram on motor nameplate. If nameplate diagram differs from diagrams above, follow nameplate diagram.**

1. Install, ground, wire and maintain your pump in compliance with the National Electrical Code (NEC) in the U.S., or the Canadian Electrical Code (CEC), as applicable, and with all local codes and ordinances that apply. Consult your local building inspector for code information.

2. Provide a correctly fused disconnect switch for protection while working on motor. For switch requirements, consult your local building inspector for information about codes.
  3. Disconnect power before servicing motor or pump. If the disconnect switch is out of sight of pump, lock it open and tag it to prevent unexpected power application.
  4. Ground the pump permanently using a wire of the same size as that specified in wiring chart (Page 3). Make ground connection to green grounding terminal under motor canopy marked GRD. or Ⓧ.
  5. Connect ground wire to a grounded lead in the service panel or to a metal underground water pipe or well casing at least 10 feet long. Do not connect to plastic pipe or insulated fittings.
  6. Protect current carrying and grounding conductors from cuts, grease, heat, oil, and chemicals.
  7. Connect current carrying conductors to terminals L1 and L2 under motor canopy. When replacing motor, check wiring diagram on motor nameplate against Figure 3. If the motor wiring diagram does not match either diagram in Figure 3, follow the diagram on the motor.
- IMPORTANT:** 115/230 Volt single phase models are shipped from factory with motor wired for 230 volts. If power supply is 115 volts, remove motor canopy and reconnect motor as shown in Figure 3. Do not try to run motor as received on 115 volt current.
8. Motor has automatic internal thermal overload protection. If motor has stopped for unknown reasons, thermal overload may restart it unexpectedly, which could cause injury or property damage. Disconnect power before servicing motor.
  9. If this procedure or the wiring diagrams are confusing, consult a licensed electrician.

# SERVICE

## PUMP SERVICE

This centrifugal pump requires little or no service other than reasonable care and periodic cleaning. Occasionally, however, a shaft seal (Key No. 4, Page 6) may become damaged and must be replaced. The procedure as outlined below will enable you to replace the seal.

**NOTICE:** These mechanical seals are supplied with either a rubber seat ring or a sealing O-Ring. They are completely interchangeable.

**NOTICE:** The highly polished and lapped faces of this seal are easily damaged. Read instructions and handle the seal with care.

Some models are equipped with an impeller screw, which has a left hand thread. Before unscrewing the impeller, remove the impeller screw.

## REMOVAL OF OLD SEAL

1. After unscrewing impeller (Key No. 5, Page 6), carefully remove rotating part of seal by prying up on sealing washer, using two screwdrivers (see Figure 4A). Use care not to scratch motor shaft.
2. Remove seal plate (Key No. 3) from motor and place on flat surface, face down. Use a screwdriver to push ceramic seat out from seal cavity (see Figure 4B).

## INSTALLATION OF FLOATING SEAT

(Figure 4C)

1. Clean polished surface of floating (ceramic) seat with clean cloth.
2. Turn seal plate over so seal cavity is up; clean cavity thoroughly.
3. Lubricate outside rubber surface or O-Ring of ceramic seat with soapy water and press firmly into seal cavity with finger pressure. If seat will not locate properly in this manner, place cardboard washer over polished face of seat and press into seal cavity using a 3/4" socket or 3/4" piece of standard pipe.
4. **DISPOSE OF CARDBOARD WASHER.** Be sure polished surface of seat is free of dirt and has not been damaged by insertion. Remove excess soapy water.

## INSTALLATION OF ROTATING PART OF SEAL UNIT

(Figure 4D)

1. Reinstall seal plate using extreme caution not to hit ceramic portion of seal on motor shaft.
2. Inspect shaft to make sure that it is clean.
3. Clean face of sealing washer with clean cloth.
4. Lubricate inside diameter and outer face of rubber drive ring (see Figure 4D) with soapy water and slide assembly on motor shaft (sealing face first) until rubber drive ring hits shaft shoulder.
5. Screw impeller on shaft until impeller hub hits shaft shoulder. This will automatically locate seal in place and move the sealing washer face up against the facing seat. Reinstall impeller screw (if used).

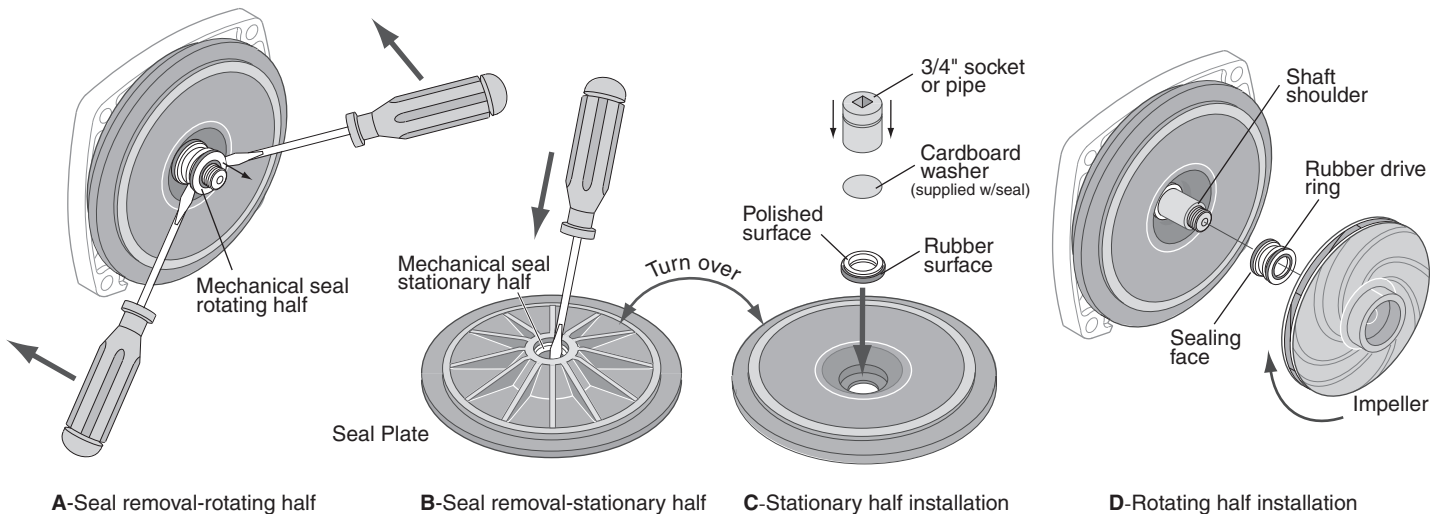
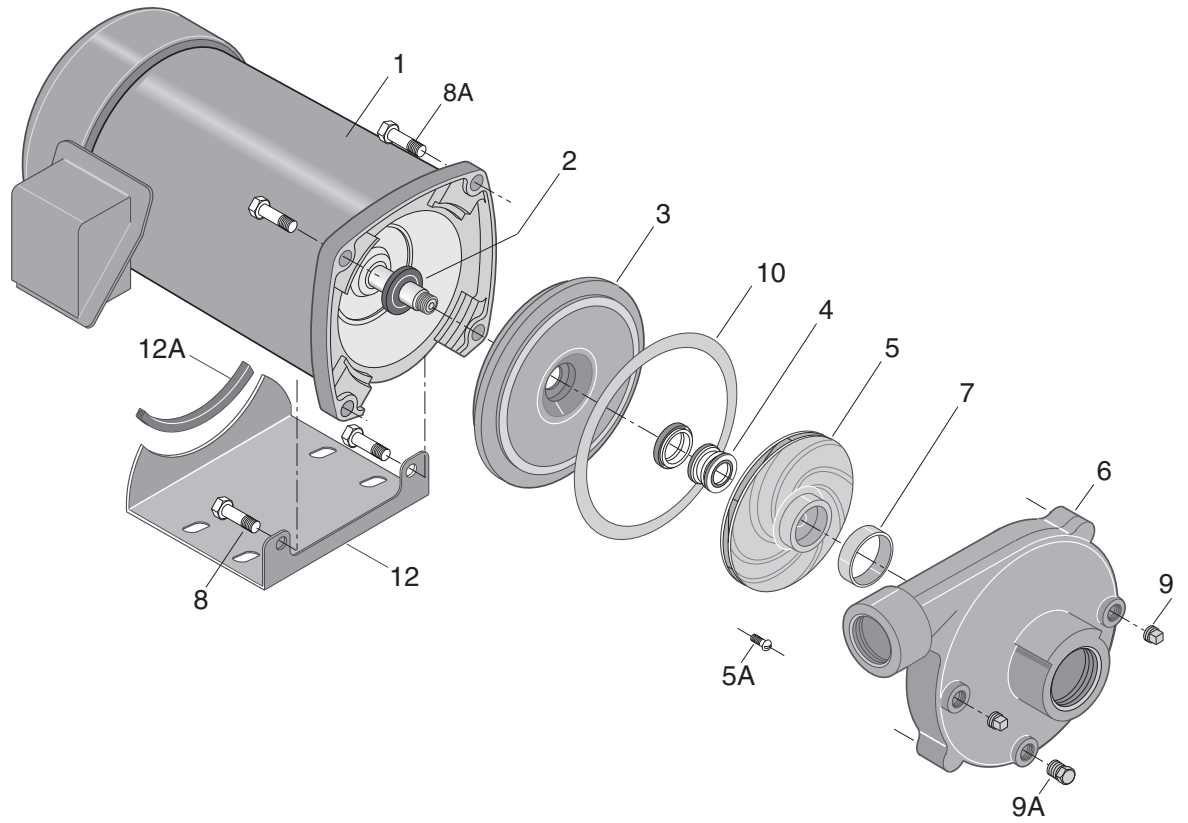

FIGURE 4

5939 0109



**Capscrew Configuration**

1228T 0894

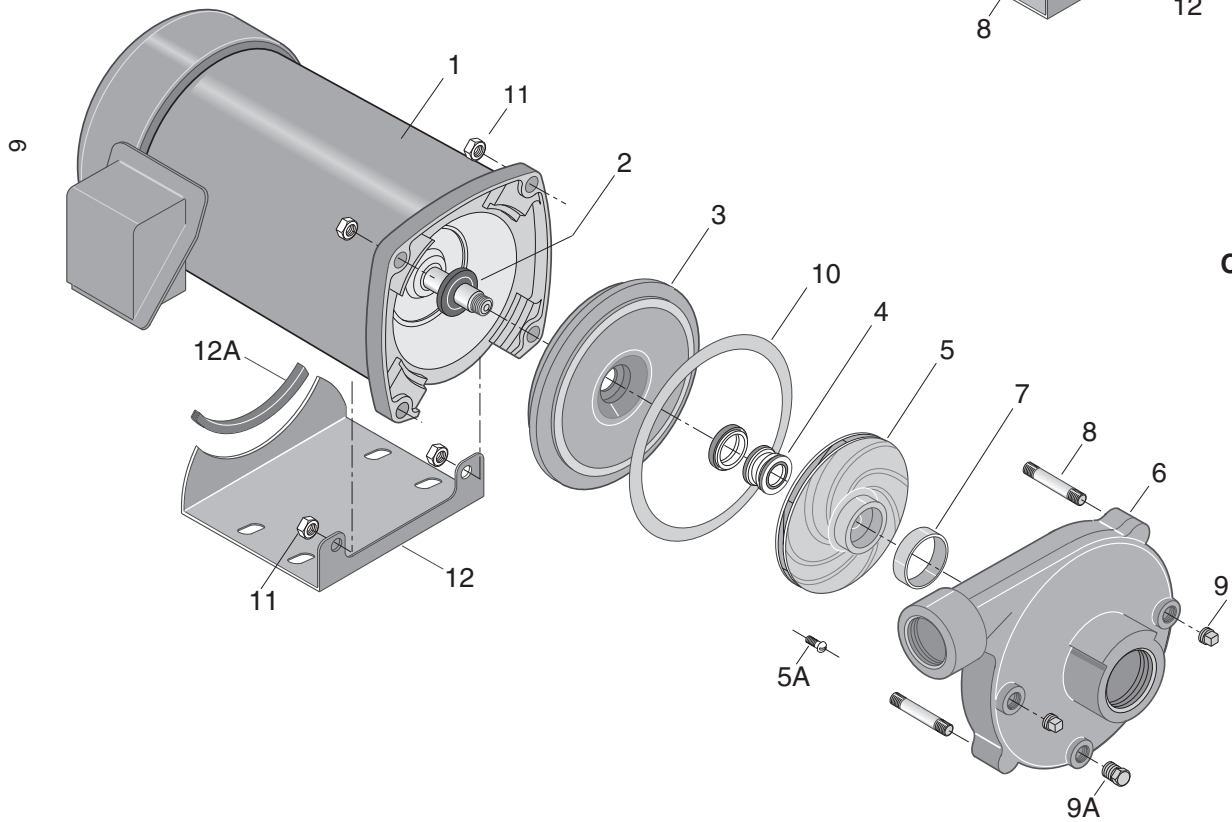

**Stud Configuration**

1228T 0894

## REPAIR PARTS LIST – MEDIUM HEAD – NORYL® IMPELLER – TEFC MOTOR

Key No.	Part Description	No. Used	MOTOR AND HORSEPOWER				
			CP1MPS		CP1 1/2 XPS		
			1/2 HP 05CPM11T 05CPM53T	3/4 HP 07CPM11T 07CPM53T	1 HP 10CPM11T 10CPM53T	1-1/2 HP 15CPM11T 15CPM53T	2 HP 20CPM21T 20CPM53T
1*	Motor - 115/230V, 60 Cycle, Single Phase	1	A100CL-T	A100DL-T	A100EL-T	A100FL-T	–
1*	Motor - 230V, 60 Cycle, Single Phase	1	–	–	–	–	AE100GL-T
1*	Motor - 575V, 60 Cycle, Three Phase	1	J218-996AC	J218-997AC	J218-998AC	J218-999AC	J218-1000AC
2	Water Slinger	1	C69-2	C69-2	C69-2	C69-2	C69-2
3	Seal Plate	1	N3-8	N3-8	N3-8	C3-52	C3-52
4	Shaft Seal	1	U109-93SS	U109-93SS	U109-93SS	U109-93SS	U109-93SS
5	Impeller - Single Phase	1	J105-42PH	J105-42PJ	J105-42PP	C105-114PC	C105-114PNA
5	Impeller - Three Phase	1	J105-42PHA	J105-42PJA	J105-42PPA	C105-114PCA	C105-114PNA
5A	Impeller Screw - Single Phase	1	–	–	–	–	C30-14
5A	Impeller Screw - Three Phase	1	C30-20	C30-20	C30-20	C30-14	C30-14
6	Volute Assembly - Complete	1	–	–	–	C201-123	C201-123
6	Volute Assembly - w/Wear Ring	1	C101-122E	C101-122E	C101-122	–	–
7	Wear Ring (only)	(1)	N23-7	N23-7	N23-7	C23-19	C23-19
8	Studs - 3/8 - 16 x 2" Lg.	(4)	–	–	–	U30-29	U30-29
9	Pipe Plug - 1/4" NPT	(3)	–	–	–	U78-57CT	U78-57CT
9A	Drain Plug - 1/4" NPT	(1)	–	–	–	U78-941ZPV	U78-941ZPV
8	Capscrew - 3/8 - 16 x 1-1/2" Lg.	2	U30-76ZP	U30-76ZP	U30-76ZP	–	–
8A	Capscrew - 3/8 - 16 x 1-1/4" Lg.	2	U30-75ZP	U30-75ZP	U30-75ZP	–	–
9	Pipe Plug - 1/4" NPT	3	U78-57CT	U78-57CT	U78-57CT	–	–
9A	Drain Plug - 1/4" NPT	1	U78-941ZPV	U78-941ZPV	U78-941ZPV	–	–
10	Gasket - Volute	1	N20-26	N20-26	N20-26	C20-21	C20-21
11	Nuts - 3/8 - 16 Hex	4	–	–	–	U36-38ZP	U36-38ZP
12	Base	1	J4-9A	J4-9A	J4-9A	J4-9A	J4-9A
12A	Motor Pad	1	C35-5	C35-5	C35-5	C35-5	C35-5

\* For repair or service to motors, always give the motor Model Number and any other data found on the Motor Model Plate.

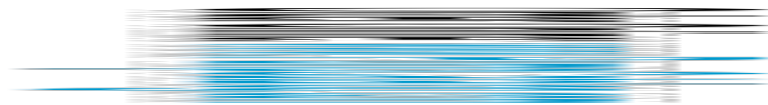



## REPAIR PARTS LIST – MEDIUM HEAD – BRASS IMPELLER – TEFC MOTOR

Key No.	Part Description	No. Used	MOTOR AND HORSEPOWER					
			CB1MPS		CB1 1/2 XPS			CB1 1/2 XPS
			1/2 HP 05CBM11T 05CBM53T	3/4 HP 07CBM11T 07CBM53T	1 HP 10CBM11T 10CBM53T	1-1/2 HP 15CBM11T 15CBM53T	2 HP 20CBM53T	2-1/2 HP 25CBM53T
1*	Motor - 115/230V, 60 Cycle, Single Phase	1	A100CL-T	A100DL-T	A100EL-T	A100FL-T	–	–
1*	Motor - 575V, 60 Cycle, Three Phase	1	J218-996AC	J218-997AC	J218-998AC	J218-999AC	J218-1000AC	J218-1001AC
2	Water Slinger	1	17351-0009	17351-0009	17351-0009	17351-0009	17351-0009	17351-0009
3	Seal Plate	1	N3-8	N3-8	N3-8	C3-52	C3-52	C3-52
4	Shaft Seal	1	U109-6A	U109-6A	U109-6A	U109-6A	U109-6A	U109-6A
5	Impeller - Single Phase	1	J105-42CA	J105-42BA	J105-42HA	C105-79	C105-73A	C105-80BA
5	Impeller - Three Phase	1	J105-42CA	J105-42BA	J105-42HA	C105-79	C105-73A	C105-80BA
5A	Impeller Screw - Single Phase	1	–	–	–	–	C30-14	C30-12
5A	Impeller Screw - Three Phase	1	C30-20	C30-20	C30-20	C30-14	C30-14	C30-12
6	Volute Assembly - Complete	1	–	–	–	C201-123	C201-123	C201-123B
6	Volute Assembly - w/Wear Ring	1	C101-122E	C101-122E	C101-122	–	–	–
7	Wear Ring (only)	(1)	N23-27	N23-27	N23-27	C23-19	C23-19	C23-19
8	Studs - 3/8 - 16 x 2" Lg.	(4)	–	–	–	U30-29	U30-29	U30-29
9	Pipe Plug - 1/4" NPT	(3)	–	–	–	U78-57CT	U78-57CT	U78-57CT
9A	Drain Plug - 1/4" NPT	(1)	–	–	–	U78-941ZPV	U78-941ZPV	U78-941ZPV
8	Capscrew - 3/8 - 16 x 1-1/2" Lg.	2	U30-76ZP	U30-76ZP	U30-76ZP	–	–	–
8A	Capscrew - 3/8 - 16 x 1-1/4" Lg.	2	U30-75ZP	U30-75ZP	U30-75ZP	–	–	–
9	Pipe Plug - 1/4" NPT	3	U78-57CT	U78-57CT	U78-57CT	–	–	–
9A	Drain Plug - 1/4" NPT	1	U78-941ZPV	U78-941ZPV	U78-941ZPV	–	–	–
10	Gasket - Volute	1	N20-26	N20-26	N20-26	C20-21	C20-21	C20-21
11	Nuts - 3/8 - 16 Hex	4	–	–	–	U36-38ZP	U36-38ZP	U36-38C
12	Base	1	J4-9A	J4-9A	J4-9A	J4-9A	J4-9A	J4-9A
12A	Motor Pad	1	C35-5	C35-5	C35-5	C35-5	C35-5	C35-5

\* For repair or service to motors, always give the motor Model Number and any other data found on the Motor Model Plate.



## REPAIR PARTS LIST – HIGH HEAD – NORYL® IMPELLER – TEFC MOTOR

Key No.	Part Description	No. Used	MOTOR AND HORSEPOWER					
			CP1XPHS				CP1 <sup>1</sup> / <sub>2</sub> TPHS	CP1 <sup>2</sup> / <sub>2</sub> TPHS
			1/2 HP 05CPH11T 05CPH53T	3/4 HP 07CPH11T 07CPH53T	1 HP 10CPH11T 10CPH53T	1-1/2 HP 15CPH11T 15CPH53T	2 HP 20CPH21T 20CPH33T 20CPH53T	2-1/2 HP 25CPH21T 25CPH33T 25CPH53T
1*	Motor - 115/230V, 60 Cycle, Single Phase	1	A100CL-T	A100DL-T	A100EL-T	A100FL-T	–	–
1*	Motor - 230V, 60 Cycle, Single Phase	1	–	–	–	–	AE100GL-T	AE100G5L-T
1*	Motor - 230/460V, 60 Cycle, Three Phase	1	–	–	–	–	AP100GL-T	AP100G5L-T
1*	Motor - 575V, 60 Cycle, Three Phase	1	J218-996AC	J218-997AC	J218-998AC	J218-999AC	J218-1000AC	J218-1001AC
2	Water Slinger	1	17351-0009	17351-0009	17351-0009	17351-0009	17351-0009	17351-0009
3	Seal Plate	1	C3-1042P	C3-1042P	C3-1042P	C3-1042P	C3-181	C3-181
4	Shaft Seal	1	U109-6A	U109-6A	U109-6A	U109-6A	U109-93SS	U109-93SS
5	Impeller - Single Phase	1	C105-92PN	C105-92PM	C105-92PL	C105-92PB	C105-214PCA	C105-214PA
5	Impeller - Three Phase	1	C105-92PNA	C105-92PMA	C105-92PLA	C105-92PBA	C105-214PCA	C105-214PA
5A	Impeller Screw - Single Phase	1	–	–	–	–	C30-14	C30-14
5A	Impeller Screw - Three Phase	1	C30-12	C30-12	C30-12	C30-12	C30-14	C30-14
6	Volute Assembly - Complete	1	C101-281E	C101-281E	C101-281E	C101-281E	C101-264E	C101-264E
7	Wear Ring (only)	(1)	C23-27	C23-27	C23-27	C23-27	C23-19	C23-19
8	Capscrew - 3/8 - 16 x 1" **	2	–	–	–	–	U30-74ZP	U30-74ZP
8A	Capscrew - 3/8 - 16 x 1-1/4" **	2	U30-75ZP	U30-75ZP	U30-75ZP	U30-104ZP	U30-75ZP	U30-75ZP
8	Capscrew - 3/8 - 16 x 1-1/2"	2	U30-76ZP	U30-76ZP	U30-76ZP	U30-104ZP	–	–
9	Pipe Plug - 1/4" NPT	(2)	U78-57CT	U78-57CT	U78-57CT	U78-57CT	U78-57CT	U78-57CT
9A	Drain Plug - 1/4" NPT	(1)	U78-941ZPV	U78-941ZPV	U78-941ZPV	U78-941ZPV	U78-941ZPV	U78-941ZPV
10	Gasket - Volute	1	C20-121	C20-121	C20-121	C20-121	C20-122	C20-122
12	Base	1	J4-9A	J4-9A	J4-9A	J4-9A	J4-9A	J4-9A
12A	Motor Pad	1	C35-5	C35-5	C35-5	C35-5	C35-5	C35-5

\* For repair or service to motors, always give the motor Model Number and any other data found on the Motor Model Plate.

\*\* Models 20CPH21T, 20CPH33T, 25CPH21T, 25CPH33T and 25CPH53T use (4) U30-104ZP Socket Head Capscrews.

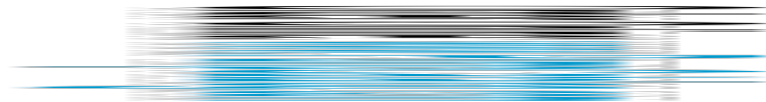

## REPAIR PARTS LIST – HIGH HEAD – BRASS IMPELLER – TEFC MOTOR

Key No.	Part Description	No. Used	MOTOR AND HORSEPOWER					
			CB1XPHS				CB1 <sup>1</sup> / <sub>2</sub> TPHS	CB1 <sup>1</sup> / <sub>2</sub> TPHS
			1/2 HP 05CBH11T 05CBH53T	3/4 HP 07CBH11T 07CBH53T	1 HP 10CBH11T 10CBH53T	1-1/2 HP 15CBH11T 15CBH53T	2 HP 20CBH21T 20CBH33T 20CBH53T	2-1/2 HP 25CBH21T 25CBH33T 25CBH53T
1*	Motor - 115/230V, 60 Cycle, Single Phase	1	A100CL-T	A100DL-T	A100EL-T	A100FL-T	–	–
1*	Motor - 230V, 60 Cycle, Single Phase	1	–	–	–	–	AE100GL-T	AE100G5L-T
1*	Motor - 230/460V, 60 Cycle, Three Phase	1	–	–	–	–	AP100GL-T	AP100G5L-T
1*	Motor - 575V, 60 Cycle, Three Phase	1	J218-996AC	J218-997AC	J218-998AC	J218-999AC	J218-1000AC	J218-1001AC
†2	Water Slinger	1	17351-0009	17351-0009	17351-0009	17351-0009	17351-0009	17351-0009
3	Seal Plate	1	C3-1042P	C3-1042P	C3-1042P	C3-1042P	C3-181	C3-181
†4	Shaft Seal	1	U109-6A	U109-6A	U109-6A	U109-6A	U109-6A	U109-6A
5	Impeller - Single Phase	1	C5-256BA	C105-94B	C5-254B	C5-254BB	C5-257BB	C5-257B
5	Impeller - Three Phase	1	C5-256BA	C105-256BAA	C5-254BA	C5-254BC	C5-257BB	C5-257B
5A	Impeller Screw - Single Phase	1	–	–	–	–	C30-14	C30-14
5A	Impeller Screw - Three Phase	1	C30-12	C30-12	C30-12	C30-12	C30-14	C30-14
6	Volute Assembly - Complete	1	C101-281E	C101-281E	C101-281E	C101-281E	C101-264E	C101-264EB
7	Wear Ring (only)	(1)	C23-27	C23-27	C23-27	C23-27	C23-19	C23-19
8	Capscrew - 3/8 - 16 x 1" **	2	–	–	–	–	U30-74ZP	U30-74ZP
8A	Capscrew - 3/8 - 16 x 1-1/4" **	2	U30-75ZP	U30-75ZP	U30-75ZP	U30-104ZP	U30-75ZP	U30-75ZP
8	Capscrew - 3/8 - 16 x 1-1/2"	2	U30-76ZP	U30-76ZP	U30-76ZP	U30-104ZP	U30-76ZP	U30-76ZP
9	Pipe Plug - 1/4" NPT	(3)	U78-57CT	U78-57CT	U78-57CT	U78-57CT	U78-57CT	U78-57CT
9A	Drain Plug - 1/4" NPT	(1)	U78-941ZPV	U78-941ZPV	U78-941ZPV	U78-941ZPV	U78-941ZPV	U78-941ZPV
†10	Gasket - Volute	1	C20-121	C20-121	C20-121	C20-121	C20-122	C20-122
12	Base	1	J4-9A	J4-9A	J4-9A	J4-9A	J4-9A	J4-9A
12A	Motor Pad	1	C35-5	C35-5	C35-5	C35-5	C35-5	C35-5

\* For repair or service to motors, always give the motor Model Number and any other data found on the Motor Model Plate.

\*\* Models 20CBH21T, 20CBH33T, 25CBH21T, 25CBH33T and 25CBH53T use (4) U30-104ZP Socket Head Capscrews.

† Included in Seal and Gasket Kit.

## TROUBLE - CAUSES AND REMEDY

TROUBLE AND CAUSE	REMEDY
<b>FAILURE TO PUMP</b> 1. Pump not properly primed.	1. Make sure pump casing and suction line are full of water. See priming instructions.
<b>REDUCED CAPACITY AND/OR HEAD</b> 1. Air pockets or leaks in suction line. 2. Clogged impeller.	1. Check suction piping. 2. Remove and clean.
<b>PUMP LOSES PRIME</b> 1. Air leaks in suction line. 2. Excessive suction lift and operating too near shut-off point. 3. Water level drops while pumping, uncovering suction piping.	1. Check suction piping 2. Move pump nearer to water level. 3. Check water supply. Add length of pipe to suction to keep submerged end under water.
<b>MECHANICAL TROUBLES AND NOISE</b> 1. Bent shaft and/or damaged bearings. 2. Suction and/or discharge piping not properly supported and anchored.	1. Take motor to authorized motor repair shop. 2. See that all piping is supported to relieve strain on pump assembly.

### Limited Warranty

BERKELEY warrants to the original consumer purchaser ("Purchaser" or "You") of the products listed below, that they will be free from defects in material and workmanship for the Warranty Period shown below.

Product	Warranty Period
<b>Water Systems:</b>	
Water Systems Products — jet pumps, small centrifugal pumps, submersible pumps and related accessories	<i>whichever occurs first:</i> 12 months from date of original installation, or 18 months from date of manufacture
Pro-Source® Composite Tanks	5 years from date of original installation
Pro-Source® Steel Pressure Tanks	5 years from date of original installation
Pro-Source® Epoxy-Lined Tanks	3 years from date of original installation
Sump/Sewage/Effluent Products	12 months from date of original installation, or 18 months from date of manufacture
<b>Agricultural/Commercial:</b>	
Centrifugals – close-coupled motor drive, frame mount, SAE mount, engine drive, VMS, SSCX, SSHM, solids handling, submersible solids handling	12 months from date of original installation, or 24 months from date of manufacture
Submersible Turbines, 6" diameter and larger	12 months from date of original installation, or 24 months from date of manufacture

Our limited warranty will not apply to any product that, in our sole judgement, has been subject to negligence, misapplication, improper installation, or improper maintenance. Without limiting the foregoing, operating a three phase motor with single phase power through a phase converter will void the warranty. Note also that three phase motors must be protected by three-leg, ambient compensated, extra-quick trip overload relays of the recommended size or the warranty is void.

Your only remedy, and BERKELEY's only duty, is that BERKELEY repair or replace defective products (at BERKELEY's choice). You must pay all labor and shipping charges associated with this warranty and must request warranty service through the installing dealer as soon as a problem is discovered. No request for service will be accepted if received after the Warranty Period has expired. This warranty is not transferable.

BERKELEY SHALL NOT BE LIABLE FOR ANY CONSEQUENTIAL, INCIDENTAL, OR CONTINGENT DAMAGES WHATSOEVER.

THE FOREGOING LIMITED WARRANTIES ARE EXCLUSIVE AND IN LIEU OF ALL OTHER EXPRESS AND IMPLIED WARRANTIES, INCLUDING BUT NOT LIMITED TO IMPLIED WARRANTIES OF MERCHANTABILITY AND FITNESS FOR A PARTICULAR PURPOSE. THE FOREGOING LIMITED WARRANTIES SHALL NOT EXTEND BEYOND THE DURATION PROVIDED HEREIN.

Some states do not allow the exclusion or limitation of incidental or consequential damages or limitations on the duration of an implied warranty, so the above limitations or exclusions may not apply to You. This warranty gives You specific legal rights and You may also have other rights which vary from state to state.

This Limited Warranty is effective June 1, 2011 and replaces all undated warranties and warranties dated before June 1, 2011.

**In the U.S.: BERKELEY, 293 Wright St., Delavan, WI 53115**  
**In Canada: 269 Trillium Dr., Kitchener, Ontario N2G 4W5**

