

**BERKELEY®**

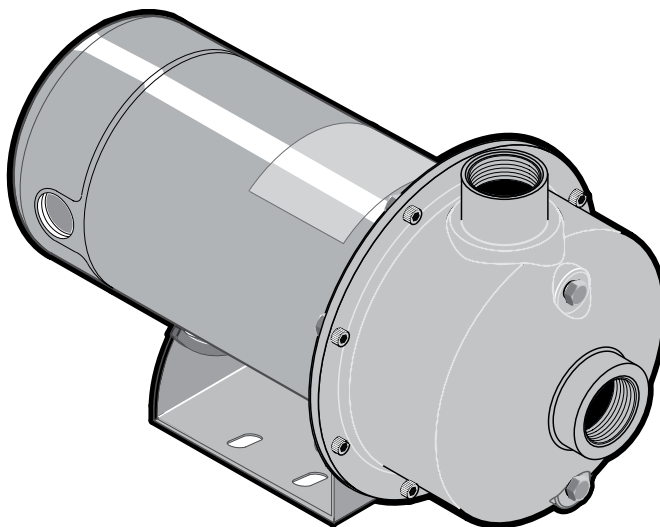

**SSCX, SSCXS Series**

HP	Model Number	ODP MOTORS		TEFC MOTORS	
		115/230/60/1	208-230/460/60/3	115/230/60/1	208-230/460/60/3
1/2	SS1XN-1/2	B78635	B78636	B78647	B78648
3/4	SS1XN-3/4	B78637	B78638	B78649	B78650
3/4	SS1XS-3/4	B82411	B82412	B82413	B82414
1	SS1XN-1	B78639	B78640	B78651	B78652
1	SS1XS-1	B82415	B82416	B82417*	B82418
1-1/2	SS1XN-11/2	B78641	B78642	B78653*	B78654
1-1/2	SS1XS-11/2	B82419	B82420	B82421	B82422
2	SS114XN-2	B78643*	B78644	B78655*	B78656
2	SS1XS-2	B82423*	B82424	B82425*	B82426
2-1/2	SS114XN-21/2	B78645*	B78646	B78657*	B78658
2-1/2	SS1XS-21/2	B82427*	B82428	B82429*	B82430

\* 230 Volt only.

**Important**

For best possible performance and continuous, satisfactory operation, read these instructions before installing your new pump. Should service be required, this manual can be a valuable guide. It should be kept near the installation for ready reference.

**Order Online: [www.PumpCatalog.com](http://www.PumpCatalog.com)**

## Important Safety Instructions

**SAVE THESE INSTRUCTIONS** - This manual contains important instructions that should be followed during installation, operation, and maintenance of the product. Save this manual for future reference.

**⚠** This is the safety alert symbol. When you see this symbol on your pump or in this manual, look for one of the following signal words and be alert to the potential for personal injury!

**⚠ DANGER** indicates a hazard which, if not avoided, *will* result in death or serious injury.

**⚠ WARNING** indicates a hazard which, if not avoided, *could* result in death or serious injury.

**⚠ CAUTION** indicates a hazard which, if not avoided, *could* result in minor or moderate injury.

**NOTICE** addresses practices not related to personal injury.

The manufacturer cannot anticipate every possible circumstance that might involve a hazard. The warnings in this manual, and the tags and decals affixed to the unit are, therefore, not all-inclusive. If you use a procedure or operating technique that the manufacturer does not specifically recommend, you must satisfy yourself that it is safe for you and others. You must also make sure that the procedure or operating technique that you choose does not render the system unsafe.

To avoid risk of serious bodily injury and property damage, read and follow all safety instructions in this manual and on equipment carefully before installing this pump. Keep safety labels in good condition; replace if missing or damaged.

**⚠ WARNING Risk of explosion.** The pump body may explode if used to boost pressure above 100 psi (689 kPa). Do not use this pump with inlet pressure greater than 70 psi (483 kPa). If not already in the piping system, install a pressure relief valve in the pump discharge line capable of passing the full pump flow at 100 psi (689 kPa). If local code requires installation of a pressure relief valve capable of handling the full pump flow at a pressure less than 100 psi (689 kPa), follow the code requirements.

**⚠ WARNING Risk of fire or explosion.** To avoid risk of fire and explosion, Pump Water Only with this pump. Do not pump salt water, flammable liquids or chemicals. Do not use the pump near gas pilot lights or where chemical or gas fumes are present. Use of an electric pump with liquids other than water or in an atmosphere containing chemical or gas fumes may ignite those liquids or gases and cause injury or death due to an explosion and/or fire.

**⚠ WARNING Burn hazard.** If water is trapped in the pump during operation it may turn to steam. Trapped steam can lead to an explosion and burns. Never run the pump with the outlet closed or obstructed.

### California Proposition 65 Warning

**⚠ WARNING** This product and related accessories contain chemicals known to the State of California to cause cancer, birth defects or other reproductive harm.

## Limited Warranty

BERKELEY warrants to the original consumer purchaser (“Purchaser” or “You”) of the products listed below, that they will be free from defects in material and workmanship for the Warranty Period shown below.

Product	Warranty Period
<b>Water Systems:</b>	
Water Systems Products — jet pumps, small centrifugal pumps, submersible pumps and related accessories	<i>whichever occurs first:</i> 12 months from date of original installation, or 18 months from date of manufacture
Pro-Source™ Composite Tanks	5 years from date of original installation
Pro-Source™ Steel Pressure Tanks	5 years from date of original installation
Pro-Source™ Epoxy-Lined Tanks	3 years from date of original installation
Sump/Sewage/Effluent Products	12 months from date of original installation, or 18 months from date of manufacture
<b>Agricultural/Commercial:</b>	
Centrifugals – close-coupled motor drive, frame mount, SAE mount, engine drive, VMS, SSCX, SSHM, solids handling, submersible solids handling	12 months from date of original installation, or 24 months from date of manufacture
Submersible Turbines, 6” diameter and larger	12 months from date of original installation, or 24 months from date of manufacture

Our limited warranty will not apply to any product that, in our sole judgement, has been subject to negligence, misapplication, improper installation, or improper maintenance. Without limiting the foregoing, operating a three phase motor with single phase power through a phase converter will void the warranty. Note also that three phase motors must be protected by three-leg, ambient compensated, extra-quick trip overload relays of the recommended size or the warranty is void.

Your only remedy, and BERKELEY’s only duty, is that BERKELEY repair or replace defective products (at BERKELEY’s choice). You must pay all labor and shipping charges associated with this warranty and must request warranty service through the installing dealer as soon as a problem is discovered. No request for service will be accepted if received after the Warranty Period has expired. This warranty is not transferable.

BERKELEY SHALL NOT BE LIABLE FOR ANY CONSEQUENTIAL, INCIDENTAL, OR CONTINGENT DAMAGES WHATSOEVER. THE FOREGOING LIMITED WARRANTIES ARE EXCLUSIVE AND IN LIEU OF ALL OTHER EXPRESS AND IMPLIED WARRANTIES, INCLUDING BUT NOT LIMITED TO IMPLIED WARRANTIES OF MERCHANTABILITY AND FITNESS FOR A PARTICULAR PURPOSE. THE FOREGOING LIMITED WARRANTIES SHALL NOT EXTEND BEYOND THE DURATION PROVIDED HEREIN.

Some states do not allow the exclusion or limitation of incidental or consequential damages or limitations on the duration of an implied warranty, so the above limitations or exclusions may not apply to You. This warranty gives You specific legal rights and You may also have other rights which vary from state to state.

This Limited Warranty is effective June 1, 2011 and replaces all undated warranties and warranties dated before June 1, 2011.

**In the U.S.: BERKELEY, 293 Wright St., Delavan, WI 53115**  
**In Canada: 269 Trillium Dr., Kitchener, Ontario N2G 4W5**

## Recommended pump suction and discharge connections

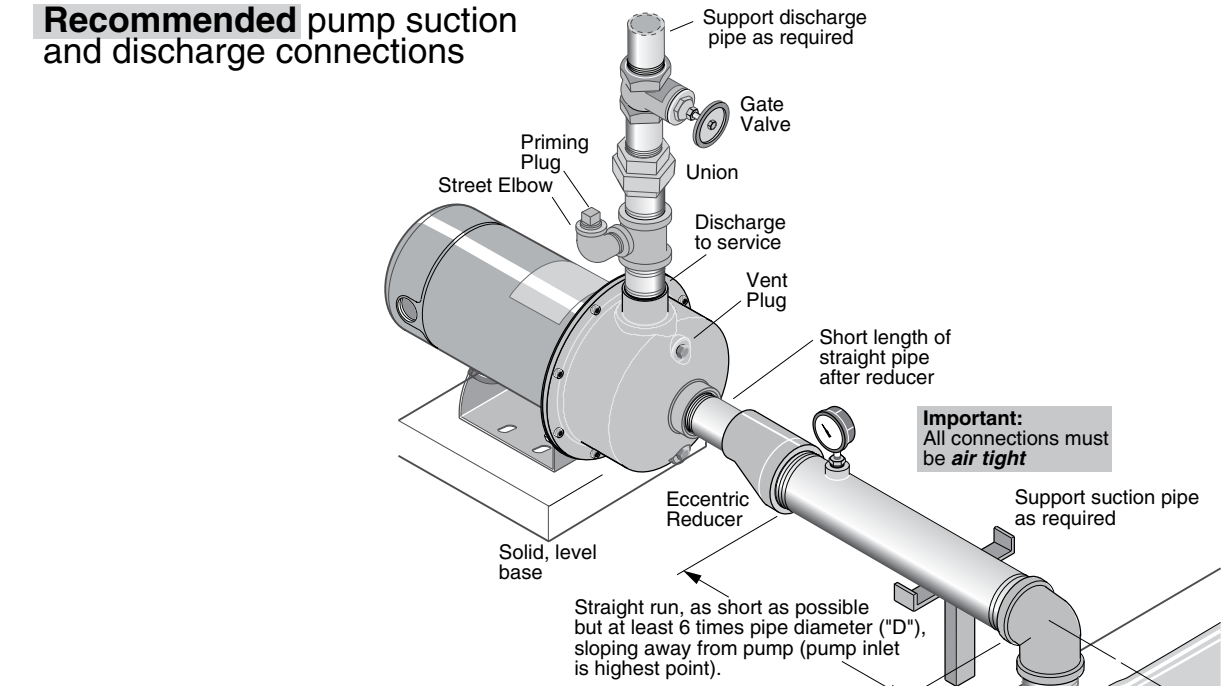

Figure 1

## Not recommended pump suction and discharge connections

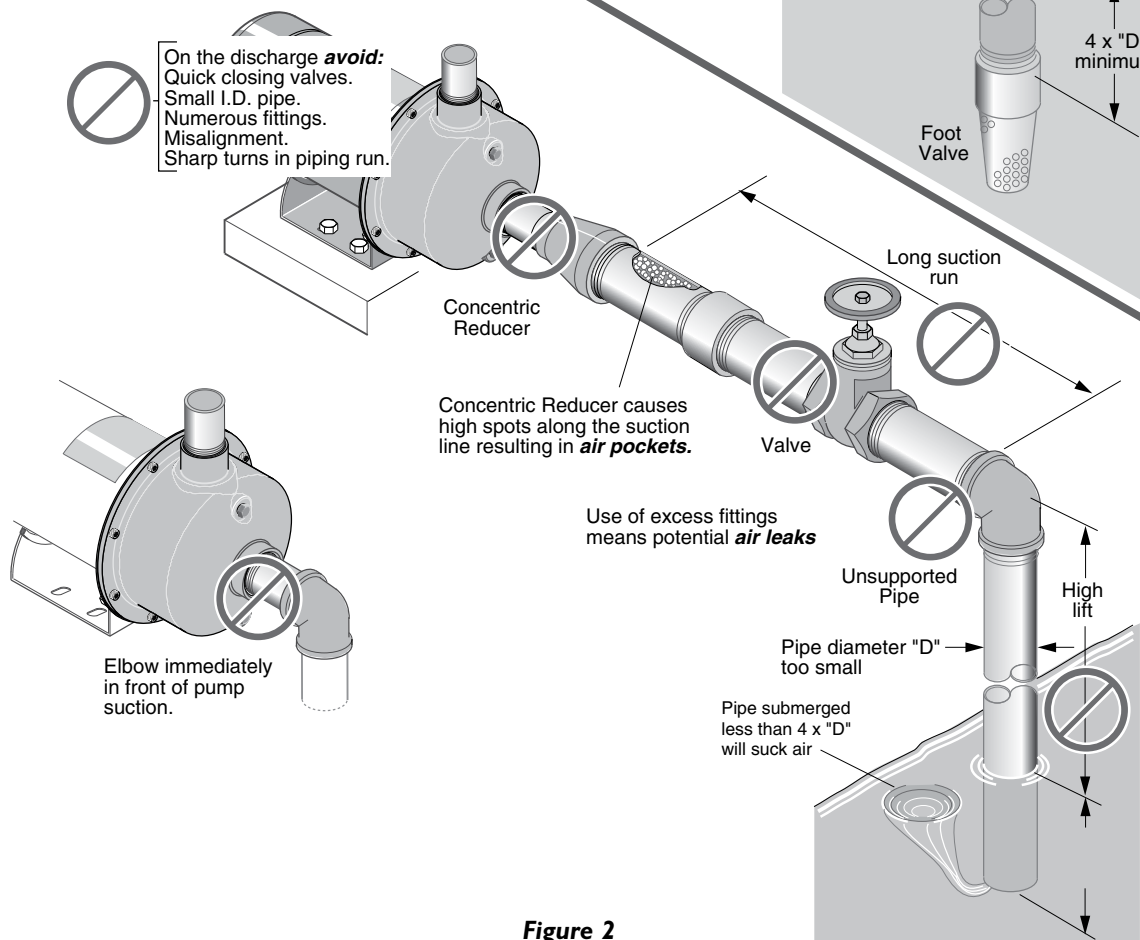

Figure 2

## Piping - General

Support both suction and discharge piping independently at a point near the pump to avoid putting a strain on the pump housing. Start all piping AT THE PUMP.

Increase pipe diameter at both the suction and discharge by one (1) standard pipe size (minimum) to obtain desired performance and flow rate. Refer to Table I when sizing pipe for your pumping system.

**NOTICE** Do not use pipe with smaller diameter on the suction side of pump.

**Table I**

Pipe Tapping Size On Pump		Recommended Pipe Size	
Suction	Discharge	Suction	Discharge
1-1/4	1	1-1/2	1-1/4
1-1/2	1-1/4	2	1-1/2

## Suction Pipe

Increase pipe size from pump tapping as shown in Table I.

Figure 1 depicts a recommended run of pipe and fittings for the suction side of a centrifugal pump. Please refer to this illustration when choosing pipe and fittings for your suction connection.

**NOTICE** All connections must be air tight!

Figure 2 depicts conditions that are NOT DESIRABLE on the suction side of a centrifugal pump and may cause problems in flow rate and priming. Please look this illustration over carefully before choosing pipe and fittings for your suction connection.

## Discharge Piping

Increase pipe size from pump tapping as shown in Table I. Figure 1 depicts a recommended run of pipe and fittings for the discharge. Install tee with priming plug as close to pump as possible. Figure 2 notes conditions that should be avoided. Please read over carefully before making discharge connection.

## Priming The Pump

A pump is primed when all air in the suction line and pump volute has been evacuated and replaced with water.

### To Prime:

1. Close valve in discharge line.
2. Remove priming plug from tee and fill pump and suction line with water until water is flowing back out of tee.
3. Replace priming plug.
4. Start pump and slowly open valve until desired water flow is achieved.

**NOTICE** If no water is pumped after 5 minutes, turn off pump, close valve, and repeat steps 1 thru 4.

**⚠ WARNING Risk of explosion and scalding.** Never run pump against closed discharge. To do so can boil water inside pump, causing hazardous pressure buildup and possible explosion.

**⚠ CAUTION Risk of flooding.** Can cause personal injury and/or property damage. Do not run the pump dry. This will damage mechanical seal and void warranty. It may cause burns to person handling pump.

**⚠ CAUTION Risk of burns.** Motor normally operates at high temperature and will be too hot to touch. It is protected from heat damage during operation by an automatic internal cutoff switch. Before handling pump or motor, stop motor and allow it to cool for 20 minutes.

## Connection Diagram For Dual Voltage, Single-Phase Motors

Your dual-voltage motor's terminal board (under the motor end cover) will match one of the diagrams below. Follow that diagram if necessary to convert motor to 115 Volt power. Connect power supply wires to L1 and L2.

For TEFC motors, see Figure 5.

For 3-phase motors, TEFC motors, and motors that do not match these pictures, follow the connection diagram on the motor nameplate, or in the connection box.

**The motor is set for 230 volts when shipped.**

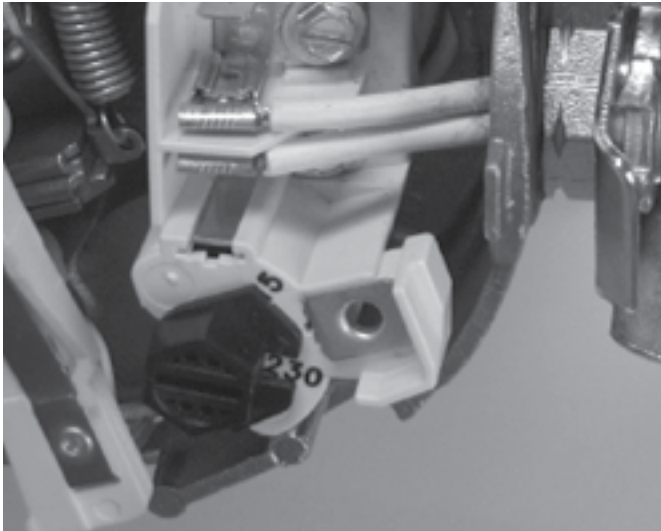

**Figure 3: 230 Volt Setting**

To change the motor to use 115 volts:

1. Turn off power
2. Remove the back motor cover.
3. Use a 1/2" wrench to turn the voltage selector dial counterclockwise until 115 shows in the dial opening.
4. Reinstall the motor cover.



**Figure 4: Motor Set for 115 Volt Operation**

## Wiring

**⚠ WARNING Risk of electric shock.** Can shock, burn or kill. Disconnect power to motor before working on pump or motor. Ground motor before connecting to power supply.

- Ground motor before connecting to electrical power supply. Failure to ground motor can cause severe or fatal electrical shock hazard.
- Do not ground to a gas supply line.  
To avoid dangerous or fatal electrical shock, turn OFF power to motor before working on electrical connections.
- Supply voltage must be within  $\pm 10\%$  of nameplate voltage. Incorrect voltage can cause fire or damage motor and voids warranty. If in doubt consult a licensed electrician.
- Use wire size specified in Table II. If possible, connect pump to a separate branch circuit with no other appliances on it.
- Wire motor according to diagram on motor nameplate. If nameplate diagram differs from diagrams above, follow nameplate diagram.

## ODP Motors, Single Phase

1. Install, ground, wire and maintain your pump in compliance with the National Electrical Code (NEC) in the U.S., or the Canadian Electrical Code (CEC), as applicable, and with all local codes and ordinances that apply. Consult your local building inspector for code information.
2. Provide a correctly fused disconnect switch for protection while working on motor. For switch requirements, consult your local building inspector for information about codes.
3. Disconnect power before servicing motor or pump. If the disconnect switch is out of sight of pump, lock it open and tag it to prevent unexpected power application.
4. Ground the pump permanently using a wire of the same size as that specified in wiring chart (Page 3). Make ground connection to green grounding terminal under motor canopy marked GRD. or  $\oplus$ .
5. Connect ground wire to a grounded lead in the service panel or to a metal underground water pipe or well casing at least 10 feet long. Do not connect to plastic pipe or insulated fittings.
6. Protect current carrying and grounding conductors from cuts, grease, heat, oil, and chemicals.

## Table II - Recommended Fusing And Wiring Data - 60/50 Cycle Motors

Model	Motor Hp	Voltage	Max. Load Amperes	Branch Fuse* Rating Amps	Distance In Feet From Motor To Meter								
					0' To 100'	101' To 200'	201' To 300'	301' To 400'	401' To 500'				
					Wire Size								
<b>Single Phase - ODP Motors</b>													
SS1XN-1/2	1/2	115/230	9.9/4.95	15/15	14/14	10/14	10/14	6/14	6/12				
SS1XN-3/4	3/4		12.4/6.2	20/15	12/14		8/14	8/14		6/12			
SS1XS-3/4	1		14.8/7.4			25/15		10/14	6/12		6/14	4/10	
SS1XN-1			19.9/9.95	30/15	6/12		4/10						
SS1XS-1	1-1/2		24.0/12.0			8/12		6/12	4/10				
SS1XN-11/2			2	26.0/13.0	35/20		8/12			4/10			
SS1XS-11/2	2-1/2		35/20			8/12		4/10					
SS11/4XN-2				2	35/20		8/12		4/10				
SS1XS-2	2-1/2		35/20	8/12		4/10							
SS11/4XN-21/2					2-1/2		35/20	8/12	4/10				
SS1XS-21/2	2-1/2	35/20	8/12	4/10									
<b>Single Phase - TEFC Motors</b>													
SS1XN-1/2	1/2	115/230	8.2/4.1	15/15	14/14	12/14	10/14	8/14	8/12				
SS1XN-3/4	3/4		11.6/5.8	20/15	12/14	10/14	8/14	6/14	6/12				
SS1XS-3/4			13.2/6.6					6/12					
SS1XN-1	1	230	6.9	15	14	14	12	12	12				
SS1XS-1	1-1/2		8.7							12	10		
SS1XN-11/2			9.8									10	10
SS1XS-11/2	2		10			10							
SS11/4XN-2	2-1/2						10	10					
SS1XS-2			2-1/2			10			10				
SS11/4XN-21/2	2-1/2	10	10										
SS1XS-21/2	2-1/2			10	10								
<b>Three Phase - ODP Motors</b>													
SS1XN-1/2	1/2	230/460	2.3/1.15	15	14/14	14/14	14/14	14/14	14/14				
SS1XN-3/4	3/4		3.1/1.55							12/14	10/14	8/14	6/12
SS1XS-3/4			3.6/1.8										
SS1XN-1	1		4.7/2.35							6/12	4/10		
SS1XS-1	1-1/2		6.8/2.4									4/10	3/8
SS1XN-11/2			2			8.5/4.25	3/8	3/8					
SS1XS-11/2	2-1/2		8.5/4.25						3/8	3/8			
SS11/4XN-2						2-1/2	8.5/4.25	3/8			3/8		
SS1XS-2	2-1/2		8.5/4.25			3/8			3/8				
SS11/4XN-21/2	2-1/2						8.5/4.25	3/8		3/8			
SS1XS-21/2	2-1/2	8.5/4.25	3/8	3/8									
<b>Three Phase - TEFC Motors</b>													
SS1XN-1/2	1/2	208-230/460	2.2/1.1	15	14/14	14/14	14/14	14/14	14/14				
SS1XN-3/4	3/4		2.9/1.45							12/14	10/14	8/14	6/12
SS1XS-3/4			3.6/6.8										
SS1XN-1	1		4.8/2.4							6/12	4/10		
SS1XS-1	1-1/2		6.0/3.0									4/10	3/8
SS1XN-11/2			2			7.0/3.5	3/8	3/8					
SS1XS-11/2	2-1/2		7.0/3.5						3/8	3/8			
SS11/4XN-2						2-1/2	7.0/3.5	3/8			3/8		
SS1XS-2	2-1/2		7.0/3.5			3/8			3/8				
SS11/4XN-21/2	2-1/2						7.0/3.5	3/8		3/8			
SS1XS-21/2	2-1/2	7.0/3.5	3/8	3/8									

\*Time delay fuse or circuit breakers are recommended in any motor circuit.

7. Connect current carrying conductors to terminals L1 and L2 under motor canopy. When replacing motor, check wiring diagram on motor nameplate against Figure 3. If the motor wiring diagram does not match either diagram in Figure 3, follow the diagram on the motor.

**NOTICE** 115/230 Volt single phase models are shipped from factory with motor wired for 230 volts. If power supply is 115 volts, remove motor canopy and reconnect motor for 230 volts. Do not try to run motor as received on 115 volt current.

8. Motor has automatic internal thermal overload protection. If motor has stopped for unknown reasons, thermal overload may restart it unexpectedly, which could cause injury or property damage. Disconnect power before servicing motor.

9. If this procedure or the wiring diagrams are confusing, consult a licensed electrician.

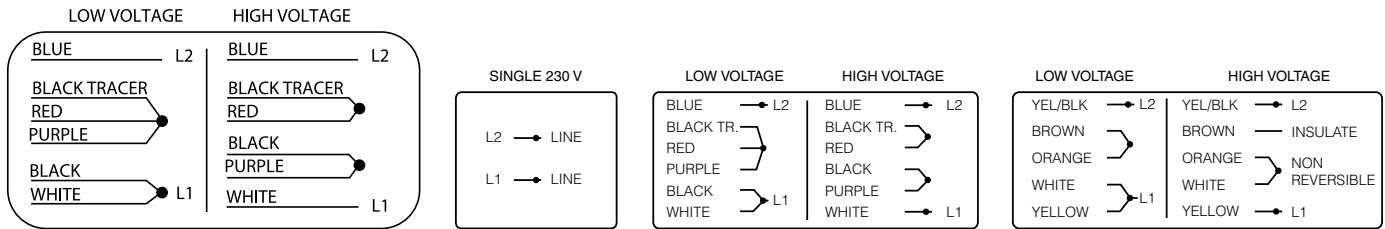

**Figure 5: Wiring connection diagram for 115/230V Dual Voltage and 230V Single Voltage TEFC motors. Follow either diagram if wire colors do not match.**

## Troubleshooting

Symptom	Possible Cause(s)	Corrective Action
Failure to pump.	Pump not properly primed.	Make sure pump casing and suction line are full of water. See priming instructions.
Reduced capacity and/or head.	Air pockets or leaks in suction line.	Check suction piping.
	Clogged impeller.	Remove and clean.
Pump loses prime.	Air leaks in suction line.	Check suction piping.
	Excessive suction lift and operating too near shut-off point.	Move pump nearer to water level.
	Water level drops while pumping, uncovering suction piping.	Check water supply. Add length of pipe to suction to keep submerged end under water.
Mechanical troubles and noise.	Bent shaft and/or damaged bearings.	Take motor to authorized motor repair shop.
	Suction and/or discharge piping not properly supported and anchored.	Confirm that all piping is supported to relieve strain on pump assembly.

## Ordering Replacement Parts:

Locate the Berkeley nameplate on pump. This plate is normally on the pump case or bracket. (Seal Plate). A typical nameplate is shown in Figure 6.

To be sure of receiving correct parts, provide all nameplate data when ordering. B.M. (Bill of Material) number is most important.

Write the nameplate information below, as nameplates can become worn or lost.

Model: \_\_\_\_\_

S.N. or Date: \_\_\_\_\_

Impeller Dia.: \_\_\_\_\_

B.M. \_\_\_\_\_

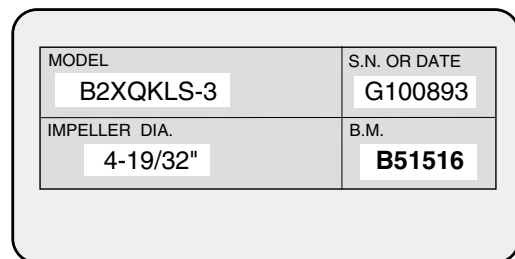

**Figure 6 - Example nameplate**

## Pump Service

This centrifugal pump requires little or no service other than reasonable care and periodic cleaning. Occasionally, however, a shaft seal may become damaged and must be replaced. The procedure as outlined below will enable you to replace the seal.

**NOTICE** Pumps use mechanical seals with a rubber seat ring or a sealing O-Ring. THESE SEALS ARE COMPLETELY INTERCHANGEABLE.

**NOTICE** The highly polished and lapped faces of this seal are easily damaged. Read instructions and handle the seal with care.

Some models are equipped with an impeller screw, which has a left hand thread. Before unscrewing the impeller, remove the impeller screw.

## Removal of Old Seal

1. After unscrewing impeller, carefully remove rotating part of seal by prying up on sealing washer, using two screwdrivers (see figure 7A). Use care not to scratch motor shaft.
2. Remove seal plate from motor and place on flat surface, face down. Use a screwdriver to push ceramic seat out from seal cavity (see figure 7B).

## Installation of Floating Seat

1. Clean polished surface of floating seat with clean cloth (figure 7C).
2. Turn seal plate over so seal cavity is up, clean cavity thoroughly.
3. Lubricate outside rubber surface of ceramic seat with soapy water and press firmly into seal cavity with finger pressure. If seat will not locate properly in this manner, place cardboard washer over polished face of seat and press into seal cavity using a 3/4" socket or 3/4" piece of standard pipe.
4. Dispose of cardboard washer. Be sure polished surface of seat is free of dirt and has not been damaged by insertion. Remove excess soapy water.

## Installation of Rotating Part of Seal

1. Reinstall seal plate (figure 7D) using extreme caution not to hit ceramic portion of seal on motor shaft.
2. Inspect shaft to make sure that it is clean.
3. Clean face of sealing washer with clean cloth.
4. Lubricate inside diameter and outer face of rubber drive ring with soapy water and slide assembly on motor shaft (sealing face first) until rubber drive ring hits shaft shoulder.
5. Screw impeller onto shaft until impeller hub hits shaft shoulder. This will automatically locate seal in place and move the sealing washer face up against seat facing. Reinstall impeller screw (if used).

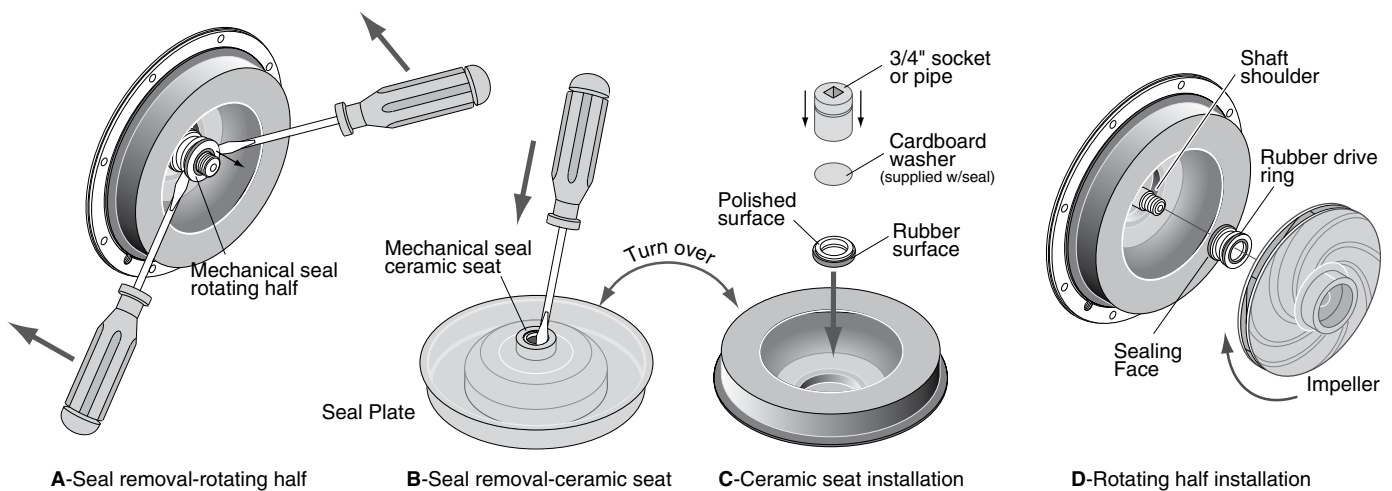

**Figure 7: Seal replacement**

SSCX Series

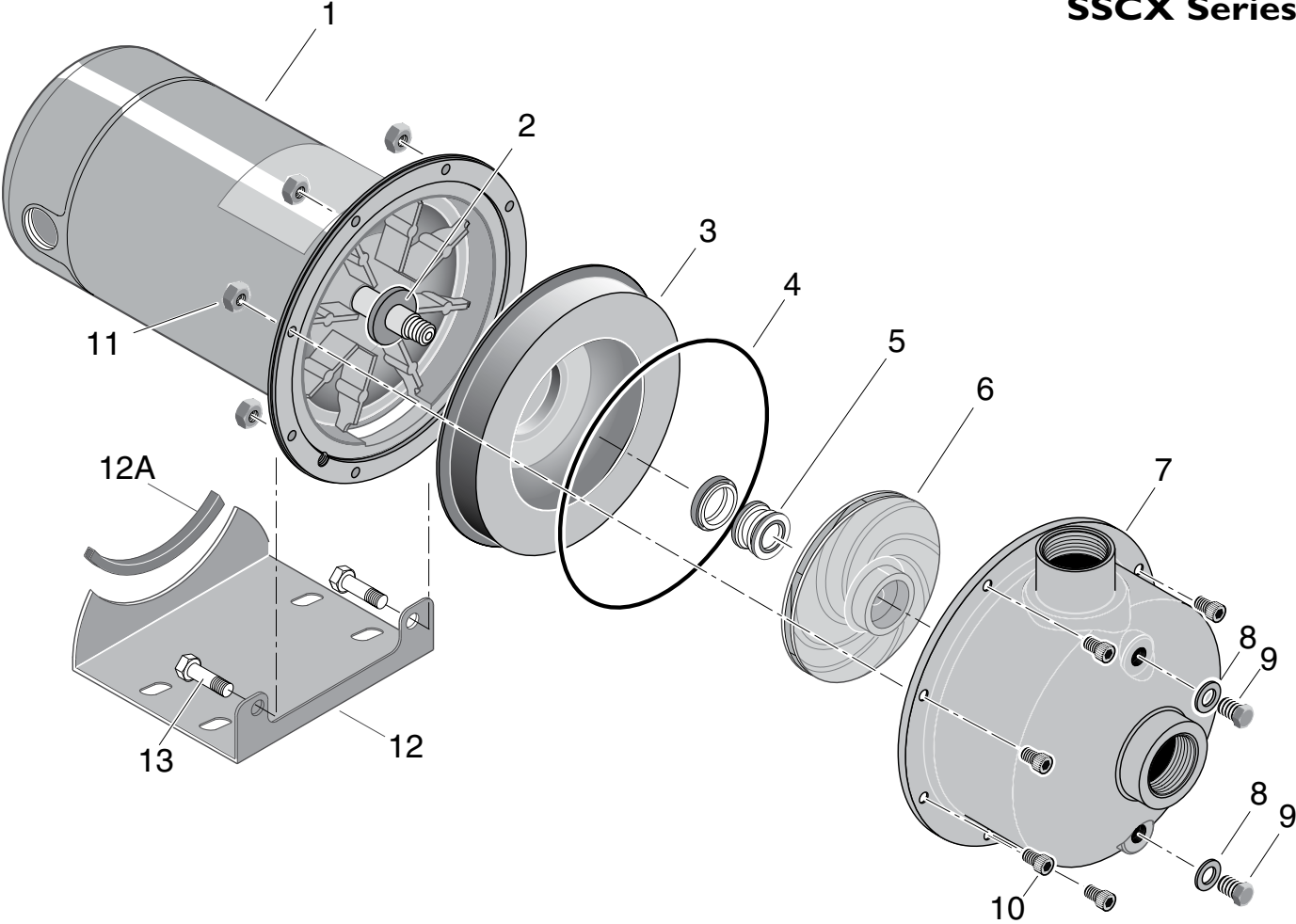

Motor and Horsepower			SS1XN-1/2	SS1XN-3/4	SS1XN-1	SS1XN-11/2	SS11/4XN-2	SS11/4XN-21/2
			B78635 B78647 B78636 B78648	B78637 B78649 B78638 B78650	B78639 B78651 B78640 B78652	B78641 B78653 B78642 B78654	B78643 B78655 B78644 B78656	B78645 B78646 B78657 B78658 B80427† B80428†† B80429† B80430††
Ref.	Description	Qty.	1/2 HP	3/4 HP	1 HP	1-1/2 HP	2 HP	2-1/2 HP
1*	Motor, 115/230V/60 Hz., 1 Phase, ODP	1	B80440	B80441	B80442	B80443	B80444	B80445
	Motor, 115/230V/60 Hz., 1 Phase, TEFC	1	B80452	B80453	B80454	B80455	B80456	B80457
	Motor, 208-230/460V/60 Hz., 3 Phase, ODP	1	B80446	B80447	B80448	B80449	B80450	B80451
	Motor, 230/460V/60 Hz., 3 Phase, TEFC	1	B80458	B80459	B80460	B80461	B80462	B80463
2	Water Slinger	1	17351-0009	17351-0009	17351-0009	17351-0009	17351-0009	17351-0009
3	Seal Plate	1	C3-200SS	C3-200SS	C3-200SS	C3-200SS	C3-200SS	C3-200SS
4	O-Ring**	1	111P0490	111P0490	111P0490	111P0490	111P0490	111P0490
5	Shaft Seal***	1	U109-6A	U109-6A	U109-6A	U109-6A	U109-6A	U109-6A
6	Impeller - 1 Phase	1	C105-92PNS	C105-92PMS	C105-92PLS	C105-92PBSS	C105-214PCASS	C105-214PASS
	Impeller - 3 Phase	1	C105-92PNESA	C105-92PMSA	C105-92PLSA	C105-92PBSSA	C105-214PCASS	C105-214PASS
•	Impeller Screw - 1 Phase	1	-	-	-	-	C30-14SS	C30-14SS
	Impeller Screw - 3 Phase	1	C30-14SS	C30-14SS	C30-14SS	C30-14SS	C30-14SS	C30-14SS
7	Casing/Diffuser Assembly	1	723S2990	723S2990	723S2990	723S2990	723S3370	723S3370
8	Washer	2	111P0990	111P0990	111P0990	111P0990	111P0990	111P0990
9	Stainless Steel Plug	2	121P3780	121P3780	121P3780	121P3780	121P3780	121P3780
10	Screw	8	121P0310	121P0310	121P0310	121P0310	121P0310	121P0310
11	Nut, M6x1	8	U36-207SS	U36-207SS	U36-207SS	U36-207SS	U36-207SS	U36-207SS
12	Base	1	J104-9F	J104-9F	J104-9F	J104-9F	J104-9F	J104-9F
	Base (1 Phase, TEFC only)	1	J104-9A	J104-9A	J104-9A	J104-9A	J104-9A	J104-9A
12A	Motor Pad	1	C35-5	C35-5	C35-5	C35-5	C35-5	C35-5
13	Capscrews, 3/8-16x3/4"	2	U30-72SS	U30-72SS	U30-72SS	U30-72SS	U30-72SS	U30-72SS

\* For repair or service to motors, always give the motor Model Number and any other data found on the Motor Model Plate.

\*\* Models B80427, B80428, B80429 and B80430 use Part Number U9-434.

\*\*\* Models B80427 and B80428 use Shaft Seal Number U109-432SS.

Models B80429 and B80430 use Shaft Seal Number U9-437.

† These models use Motor Number B80445.

†† These models use Motor Number B80451.

• Not illustrated.



SSCXS Series

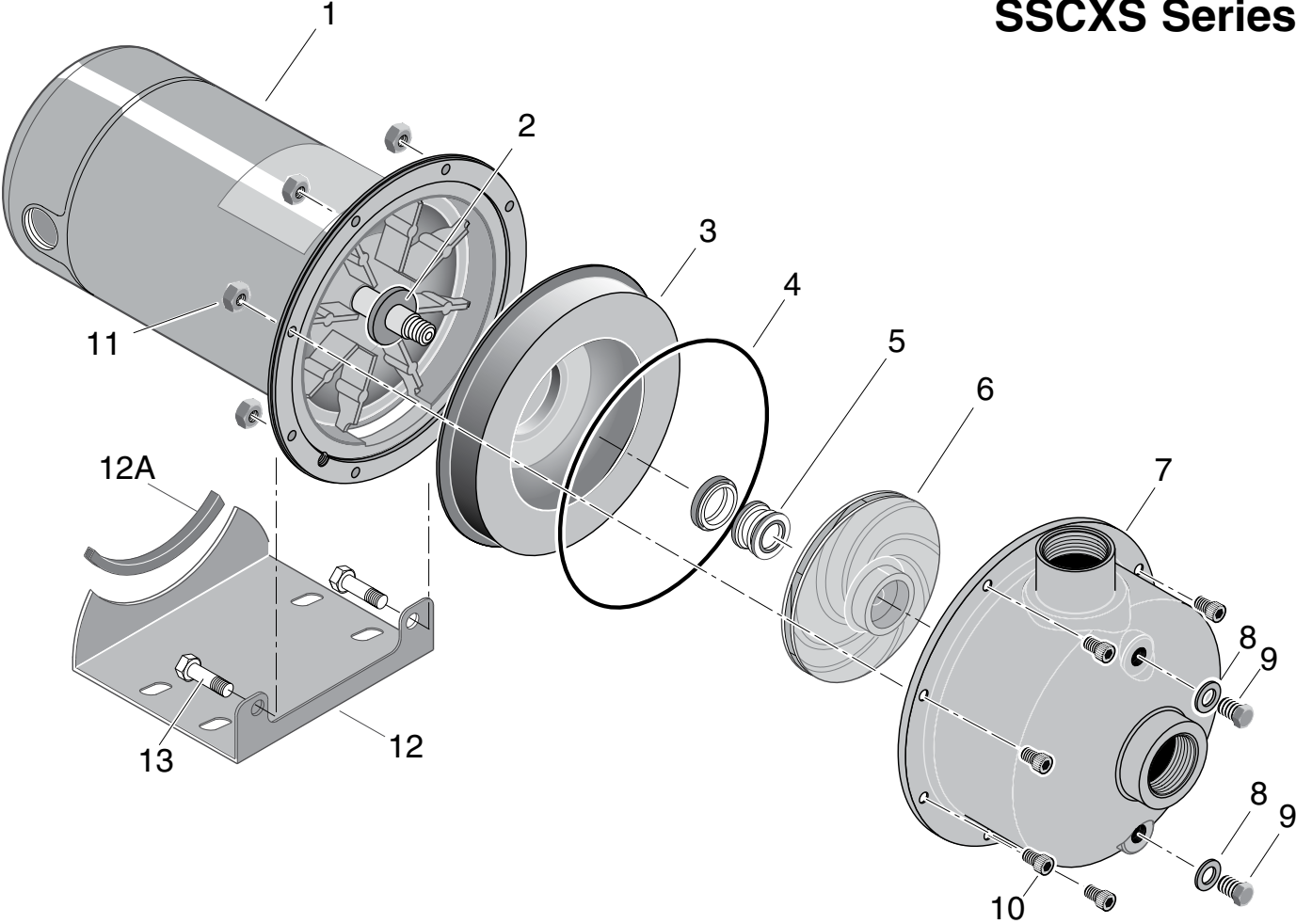

Motor and Horsepower			SS1XS-3/4	SS1XS-1	SS1XS-11/2	SS1XS-2	SS1XS-21/2
			B82414 B82413 B82412 B82411	B82418 B82417 B82416 B82415	B82422 B82421 B82420 B82419	B82426 B82425 B82424 B82423	B82430 B82429 B82428 B82427
Ref.	Description	Qty.	3/4 HP	1 HP	1-1/2 HP	2 HP	2-1/2 HP
1	Motor, 115/230V/60 Hz., 1 Phase, ODP	1	B80442	B80443	B80444	B80445	B80445
	Motor, 115/230V/60 Hz., 1 Phase, TEFC	1	B80454	B80455	B80456	B80447	B80447
	Motor, 208-230/460V/60 Hz., 3 Phase, ODP	1	B80448	B80449	B80450	B80451	B80451
	Motor, 230/460V/60 Hz., 3 Phase, TEFC	1	B80460	B80461	B80462	B80463	B80463
2	Water Slinger	1	17351-0009	17351-0009	17351-0009	17351-0009	17351-0009
3	Seal Plate	1	C3-200SS	C3-200SS	C3-200SS	C3-200SS	C3-200SS
4	O-Ring	1	U9-434	U9-434	U9-434	U9-434	U9-434
5	Shaft Seal*	1	U109-196A	U109-196A	U109-196A	U109-196A	U109-196A
6	Impeller	1	731S6230	731S6220	731S6210	731S6200	731S6190
•	Impeller Screw - 1 Phase	1	-	-	-	C30-14SS	C30-14SS
	Impeller Screw - 3 Phase	1	C30-14SS	C30-14SS	C30-14SS	C30-14SS	C30-14SS
7	Casing/Diffuser Assembly	1	723S2990	723S2990	723S2990	723S2990	723S2990
8	Washer	2	111P0990	111P0990	111P0990	111P0990	111P0990
9	Stainless Steel Plug	2	121P3780	121P3780	121P3780	121P3780	121P3780
10	Screw	8	121P0310	121P0310	121P0310	121P0310	121P0310
11	Nut, M6x1	8	U36-207SS	U36-207SS	U36-207SS	U36-207SS	U36-207SS
12	Base	1	J104-9F	J104-9F	J104-9F	J104-9F	J104-9F
	Base (1 Phase, TEFC only)	1	J104-9A	J104-9A	J104-9A	J104-9A	J104-9A
12A	Motor Pad	1	C35-5	C35-5	C35-5	C35-5	C35-5
13	Capscrews, 3/8-16x3/4"	2	U30-72SS	U30-72SS	U30-72SS	U30-72SS	U30-72SS

\* Models B82413, B82414, B82417, B82418, B82421, B82422, B82425, B82426, B82429, B82430 use Part Number U9-437.

• Not illustrated.



This page intentionally left blank

This page intentionally left blank

