

MYERS® MS1822

The Myers Pre-Plumbed Sump Basin Package is a rugged, high-quality system ideal for basement sumps and dewatering. The basin features an approved radon-proof design. The unit comes field-ready with a 1-1/2" NPT threaded discharge flange and a 2" NPT vent flange (adaptable to 3") and includes a 1-1/2" sump check valve.



APPLICATIONS

Basement sumps, dewatering, new or existing installations

SPECIFICATIONS

Capacities – 60 GPM (227 LPM)
Shut-off Head – 24' (7.31 m)
Operation – On: 7.5" (190 mm)
 Off: 3.0" (76 mm)
Solids Handling – 3/16" (4.77 mm)
Liquids Handling – Drain water
Continuous Liquid Temperature – 140°F (60°C)
Motor/Electrical Data – 1/3 HP, 115V, 4.0A, 1Ø, 60Hz
Housing – Zinc motor housing dissipates heat quickly and extends more life
Power Cord – 8', SJTW, SJTW-A
Discharge, NPT – 1-1/2" (38 mm)
Basin Size – 18" x 22" structural foam; Radon Proof, 20-gallon

FEATURES

Fully Assembled

The fully assembled system includes: pump, basin, sealed cover, internal basin discharge pipe and check valve

Stackable Design

Allows for compact inventory and shipping

Heavy-duty MS33PV1 Pump

- Maintenance-free operation
- Vertical mechanical switch for small 10" diameter sumps
- Dual ball-bearing motor and additional lip seal provide durability and longer pump life
- Durable, oil-filled PSC motor for maximum heat dissipation, continuous bearing lubrication, years of service
- Thermal overload protection with automatic reset

BASIN

- 18" x 22" corrosion-resistant structural foam construction
- 20-gallon capacity
- Hub adapter: 4" snap-in type with stainless steel clamp – fits 4" DWV SCH. 40 plastic pipe
- Flanges: 1-1/2" NPT threaded discharge and 2" NPT vent flange (converts to 3"); includes gas-tight cord grommet
- Check valve fits 1-1/2" black, galvanized, and DWV SCH. 40 pipe

BASIN COVER

Gas-tight, single-piece design with seal; structural foam construction

MYERS® MS1822

DIMENSIONS

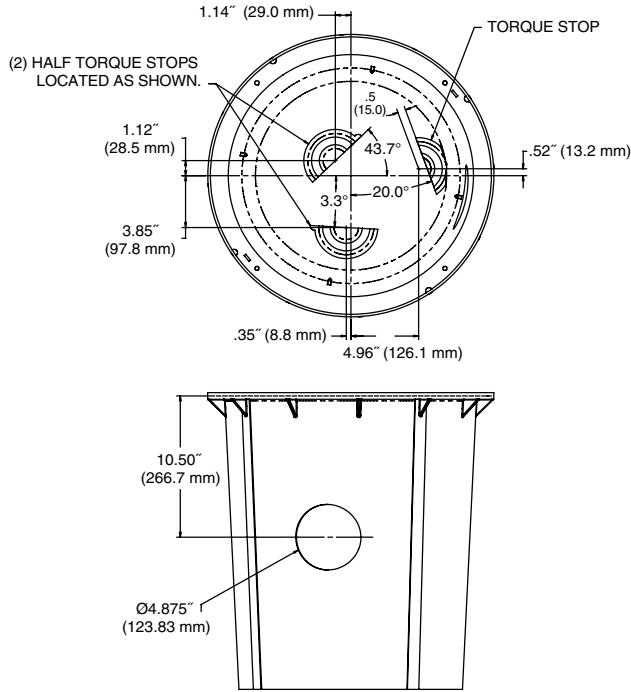

PUMP PERFORMANCE

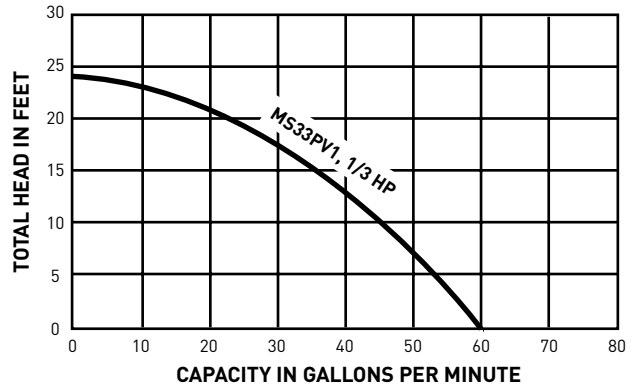

USA
 293 WRIGHT STREET, DELAVAN, WI 53115 WWW.FEMYERS.COM
 PH: 888-987-8677 ORDERS FAX: 800-426-9446

CANADA
 490 PINEBUSH ROAD, UNIT 4, CAMBRIDGE, ONTARIO N1T 0A5
 PH: 800-363-7867 ORDERS FAX: 888-606-5484

Because we are continuously improving our products and services, Pentair reserves the right to change specifications without prior notice.