

OPERATOR'S MANUAL AND PARTS LIST

for Self-Priming Centrifugal 'T' Pumps

OPERATION
& SERVICE
GUIDE
PO1750H
JAN 2012

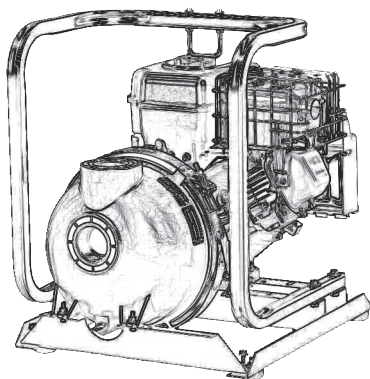

2" Engine Driven

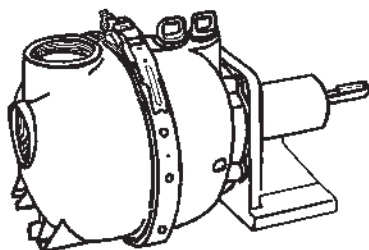

Pedestal Mounted

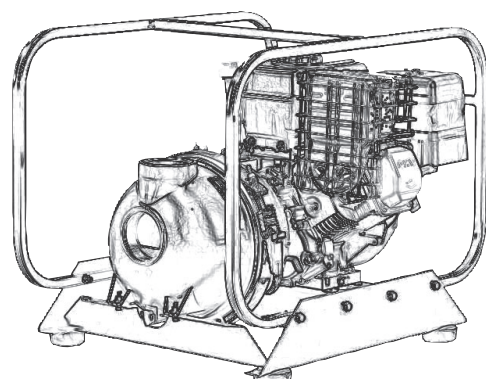

3" Engine Driven

Self-Priming • Corrosion Resistant • Lightweight • High Volume • High Lift

! SAFETY WARNING !

'T' Pumps are designed for pumping fresh or saltwater, clear or dirty. Do not use 'T' Pumps for pumping chemicals. If the water to be pumped is known to be contaminated with chemicals, contact your dealer or the factory for applications assistance. Do not use a pump that is not chemically compatible with the liquid you intend to pump or serious bodily injury, death, fire, explosion, or environmental damage could result. Pumping liquids with high solids or abrasives content will accelerate wear of certain components such as the shaft seal, impeller, volute, and wearplate. Therefore, wear should not be misconstrued as to the existence of a defect and as such would not be included in a warranty claim. Nor is it implied that such components will last through the one year warranty period without occasional, or even frequent replacement depending upon the severity of the application. Replace badly worn or damaged components to assure safe operation of this pump. Consult dealer or factory for recommendations on pumping abrasive and other difficult liquids.

I. GENERAL INSTRUCTIONS • TABLE OF CONTENTS

- A. Inspect the unit for shipping damage immediately upon receipt and before signing for merchandise. If any damage exists, note damage on shipping bill of lading or receiving document(s) before signing. Also, notify your dealer or distributor immediately of any damage to the shipment. Note that you, the receiver, are the only one who can make a claim. The carrier will not accept claims from anyone else.
- B. Read these instructions and the power unit instructions until you are sure you can operate this equipment safely and correctly.
- C. This 'T' pump has been designed to give maximum service over a long operating life. Proper care in operating and maintaining your pump will ensure its high efficiency and minimize unscheduled repairs.

PLEASE READ SECTIONS I, II, III, & IV BEFORE STARTING THE PUMP

I.	General Instructions	1(cover)
II.	Safety Precautions.....	2
III.	Preparing the Pump and Power Unit for Operation.....	2
IV.	Pump Operating Instructions.....	3
V.	Trouble Shooting and Repair.....	4
VI.	Pump Disassembly and Repair.....	4
VII.	Pedestal Mounted, Flexible Coupled Pumps:	
	A. Alignment of Coupling	4
	B. Dimensions	5
VIII.	Exploded View	6
	A. Parts List	7,8
	B. Diagram of Economy 'T' Pump.....	8

LOOK FOR THE RELEVANT EMISSIONS DURABILITY PERIOD AND AIR INDEX INFORMATION ON THE ENGINE EMISSIONS LABEL.

II. SAFETY PRECAUTIONS

WARNING:

- A. Never use these pumps for pumping flammable liquids such as gasoline. AN EXPLOSION AND SERIOUS INJURY MAY RESULT IF THIS WARNING IS IGNORED.
- B. Your 'T' pump is designed for use with water, clear or dirty, *do not use it for pumping chemicals*. Provide all needed safety precautions to protect people and property before pumping any fluids.
- C. Before starting the pump, follow all of the instructions in this manual and any supplemental instructions supplied with the pump, engine or motor.
- D. Any person operating this pump and its power unit should be fully aware of its safe operational procedures before they start using it.
- E. Never operate this unit in an explosive atmosphere, near combustible materials, or where insufficient ventilation exists to prevent any personal injury or damage. Be certain any other power unit is safe for the area in which it is to be operated. Never operate gas-powered engines indoors.
- F. Always be sure that the pump is on secure footing so that it cannot slide, shift, or tip over. If the pump is sitting beside a pit, secure it so that it does not fall in. Pump and engine units have slots and holes for fastening to a secure base. Baseplate, skid rail, and roll cage kits are available from your pump dealer.
- G. Never operate the unit with any guards removed.
- H. With engine driven pumps:
 - 1. Observe all safety precautions for the handling of fuel.
 - 2. Never refuel the engine while it is running, and care should be exercised so that no fuel is spilled on a hot engine. Always allow the engine to cool at least five minutes before refueling.
- I. Before working on this pump, make sure that the power unit cannot inadvertently be started.
- J. Be sure that the power unit, pump, and wiring and piping installations are suitable for the liquid being pumped and comply with all applicable codes and regulations.
- K. Do not use torches or apply fire or flames to this pump for any reason.
- L. This pump must not be subjected to more than 65 pounds per square inch internal pressure. The pump itself, normally cannot develop more than 55 pounds per square inch pressure. The pump must not be used under any of the following unusual conditions which can result in excessive pressures being developed:
 - 1. Pump shaft speed over 3600 RPM.
 - 2. Quick closing valves in discharge line or any other device which may introduce hydraulic shock into the system.
 - 3. Possible sudden obstruction of discharge line such as a vehicle driving over the hose.
 - 4. High positive suction pressures (such as with a flooded suction) which would increase the total system pressure to 65 PSI or above.
 - 5. Do not pump a liquid having a specific gravity greater than 1.3.
- M. Do not over tighten the drain or filler plugs. Hand tighten only. Excessive force may damage the threads or the pump body. Do not use metal plugs.
- N. Use at least one foot of flexible hose to make plumbing connections to the pump body. Rigid piping may put stresses on the pump, causing damage. If rigid piping must be used, properly support it so as to eliminate stresses on the pump.
- O. Do not tighten inlet and discharge fittings more than one turn beyond hand tight. Excessive force will damage the pump or fittings.
- P. Long suction and discharge hoses or pipes must be supported so that the weight of the hoses or pipes filled with liquid does not damage the pump or tip it over.
- Q. Use replacement parts supplied by the manufacturer only.
- R. Always fill the pump body with the liquid to be pumped before starting the pump. It is not necessary to drain the pump body after use, unless there is danger of freezing, settling of solids, or crystallization.
- S. Do not run the pump dry. Do not restrict flow through the pump with a closed discharge valve or "starved" suction line. If it is necessary to restrict flow through the pump for longer than a minute or two, it must either be stopped or a discharge bypass line installed to keep liquid temperatures below the maximum recommended operating temperature of 130° F.

III. PREPARING THE PUMP AND POWER UNIT FOR OPERATION

A. GENERAL

- 1. Inspect your unit for signs of shipping damage. Notify your dealer immediately of any damage or missing components.
- 2. Read and reread these instructions and the power unit instructions until you are sure of safe and correct operating methods.

B. Power unit preparation, gasoline engine driven pumps:

- 1. For complete operating and maintenance information read completely the engine manufacturer's instructions included with the pump.
- 2. Before starting, fill crankcase with oil specified by the engine manufacturer. Use a high quality detergent oil classified for service SC, SD, SE or MS. Do not add anything to the recommended oil.
- 3. Before starting, fill fuel tank with clean, fresh unleaded "regular" grade automotive gasoline. Do not mix oil with gasoline.

CAUTION: Always remove spark plug or spark plug wire before working on a unit to prevent accidental starting. The

engine governor is set at the factory. Do not tamper with any part which may increase the governed engine speed.

C. Power unit preparation, electric motors:

- 1. Make certain that the input power to your electric motor is proper, single phase or three phase, and is of the proper voltage according to the motor specification plate.
- 2. Be sure of the proper motor rotation. Pump impeller should rotate counterclockwise, looking from the suction inlet side. For single phase motors consult the motor manufacturer's instructions for wiring for counterclockwise rotation. Three phase motor rotation may be reversed by interchanging any two of the three power leads. Make certain that wiring for your electric motor complies with all existing codes.

D. Pump Preparation

- 1. Fill the shaft seal lubrication system with the same oil used in the engine. If motor driven, use SAE 10W40. (Oil fill cap is located behind the pump filler plug on top of the pump. See item #1A on the exploded view drawing on page 7). The initial fill will be completely used within the first few hours of operation. Refill the tube after three operating hours, check every 24 operating hours. Ensure that the shaft seal lubrication system is filled with oil as described above.



WARNING



The engine exhaust from this product contains chemicals known to the State of California to cause cancer, birth defects, or other reproductive harm.

IV. PUMP OPERATING INSTRUCTIONS

- A. Fill the pump body with clean water before starting. Avoid running your pump dry for prolonged periods. Excessive seal wear may result even with the lubrication system because pressure exerted by the liquid in the body of the full, operating pump is required to drive lubrication to the seal.
- B. Make certain that all hose and pipe connections are airtight. **Important:** An air leak in the suction line may prevent priming and will reduce the capacity of the pump. Use teflon sealing tape on all threaded fittings.
- C. Always place the pump as close as possible to the source of the liquid to be pumped. Keep all lines as short and straight as possible to minimize restrictions.

Engine driven 'T' pumps are equipped with a "wide stance" chassis which will stabilize the pump in difficult job site situations. However, always attempt to place the pump in a level, secure position for safe, efficient operation. See figure #1.
- D. If flexible hose must be laid across a roadway, protect it with planking. Instantaneous shut-off pressure applied when a vehicle runs across an unprotected hose will cause "hydraulic shock". This shock can damage the pump and/or damage the hose. See figure #2.
- E. Soft solids as large as ½ the size of the 2" & 3" suction ports may be passed. (E.g., 1" & 1½" solids respectively). To ensure that no larger solids enter the pump, always install a suction line strainer supplied by the manufacturer. If the strainer is likely to clog, use one of the methods shown below to prevent clogging (see figure #3).
- F. Drain the pump body whenever there is danger of freezing.
- G. After each use - always flush residue and solids from the pump body by the following method:
 1. Remove suction hose from body.
 2. Remove the drain plug (item #20 on parts drawing) and allow all fluid to drain from the pump body.
 3. Loosen the pump front support by rotating eye bolts (item #45) three full turns counter clockwise.
 4. Remove the V-band clamp (item #23) and pull the pump body and support forward until clear of the opposing half. Remove and wash the body O-ring (item #22) with clean water. If the impeller eye appears obstructed, remove the wear plate (item #28). Remove all obstructions. Reinstall wear plate.
 5. Rinse the pump interior and wipe the body O-ring seat areas.
 6. Reassemble the pump.

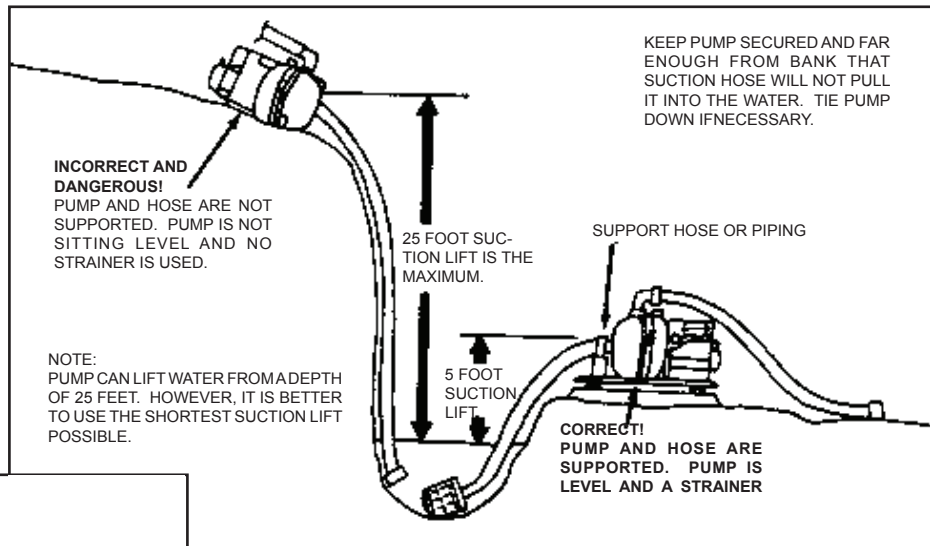

FIGURE 1



FIGURE 2

SUGGESTED WAYS TO KEEP STRAINER OUT OF RIVER SILT.

1. Prepare a bed of stones on which to rest the strainer (see Figure #3).
2. Tie the strainer so that it stays off the bottom of the excavation, etc.

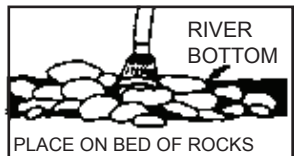

FIGURE 3

V. TROUBLE SHOOTING AND REPAIR

Good preparation and maintenance should always result in proper pump function. Despite these practices, some problems may occur. The following suggestions should be sufficient to solve most pump problems.

Note: "(Item # ...)" refers to the exploded view drawing on page 6.

Problem	Treatment
Pump will not prime after one minute of operation.	<ol style="list-style-type: none"> 1.Fill pump body to overflowing. Restart. 2.Check suction line for obstructions or loose fittings. 3.Pump speed (is engine choke still on?). Vacuum performance drops rapidly when RPM is decreased. 4.Check valve (item #24) not sealing (pump will not hold prime water). Remove obstruction. 5.Leakage at suction gasket (item #27).
Pump will prime but flow is less than usual	<ol style="list-style-type: none"> 1.See 2 and 3 above. 2.Discharge hose obstructed. 3.Check for excessive wear and clearance between wear plate and impeller. Greater than 1/16" clearance when body is removed requires replacement of either or both.
Water leaking through oil seal (item #7)	<ol style="list-style-type: none"> 1.Worn shaft seal.

VI. PUMP DISASSEMBLY AND REPAIR

Tools required:

Screw driver (broad blade, straight slot) Allen wrench 5/32" hex. Impellers with metal hubs may require a "Jackscrew" for removal. 3" pumps would require a 5/8-11 bolt. 2" pumps need a 1/2-13 bolt. Impellers with no metal hub do not require a "Jackscrew" for removal.

- A. Loosen eye or hex head bolts (item #45 on pump support (item #48) three turns.
- B. Remove clamping band (item #23) and pull body assembly (items #21 & 48) away from bracket half.
- C. Body assembly contains a rubber gasket seal (item #27) which is removable by hand, and a check valve (item #24) which is held in place by two self-tapping screws (item #26) through a retainer plate (item #25).
- D. **BRACKET DISASSEMBLY**
Remove the volute wear plate (item #28). (Note the slots in the wear plate which locate it on the volute.) Observe the inside surface for signs of excessive wear.
- E. To remove the impeller (item #16), simply remove the retainer screw (item #18) and O-ring (item #17). The impeller

should now be manually removable. Impellers with metal hubs may require a Jackscrew. Once the impeller is removed, the attached seal should be protected unless replacement is intended. Note the shims (item #13) within the impeller bore. Retain these shims and the shaft key (item #14) for later use in reassembly - even with a new impeller.

- F. To remove the seal (item #15) from the impeller, place a screwdriver through the front and press the seal out of its seat. When replacing the seal, ensure that it is fully seated within its socket and that the face is perpendicular to the shaft. Whenever the impeller seal half is replaced, the bracket seal half must be replaced at the same time (and vice versa), as the seal halves wear a path into each other. A new seal half running against a worn seal half is likely to leak.
- G. To disassemble the volute (item #11) from the bracket (item #6) on 2" series pumps, remove 2 Allen-head screws. The 3" unit requires the removal of 4 Allen-head screws (item #12). Clean and safely store the volute O-ring (item #10) until reassembly.

VII. PEDESTAL MOUNTED, FLEXIBLE COUPLED PUMPS

A. FLEXIBLE COUPLED PUMPS: COUPLING ALIGNMENT

Measure the diameter of the power unit shaft. Choose the appropriate coupling for your pump and power unit. (See flexible couplings chart number VI-A). Proper shaft and

coupling alignment reduces vibration and prevents premature coupling failure. The following eight steps help in obtaining proper shaft alignment.

1. Make sure you use a rigid base plate large enough for the assembly of the pump and the drive unit. We offer kits 58-0116 and 58-0117 for this purpose. (See baseplate kits listed after couplings chart VI-A.)**
2. Place the pump and drive unit on the base plate.
3. Measure the distance between the center line of the pump shaft and the base plate surface.
4. Measure the distance between the center line of the drive unit shaft and base plate.
5. Compare measurements obtained from steps 3 and 4 and use spacers and shims for height adjustment to ensure alignment of both shafts.
6. Place the coupling halves over each shaft, put the "spider" between the two halves and couple the two halves together.
7. To assure parallel alignment (Figure 5) place a straight edge along the side of both coupling halves in two different locations, 90° apart. The coupling is aligned when the straight edge rests squarely on the sides of both coupling halves.

8. To avoid angular misalignment, insert a measuring device (taper gauge or feeler gauge) between the coupling faces at four locations 90° apart (see arrows in Figure 6) and measure the gap at each of the four locations. For proper alignment all four measurements should be equal. Reshimming may be required to achieve this alignment.

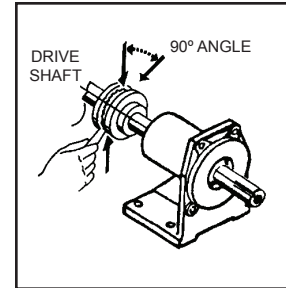

FIGURE 6

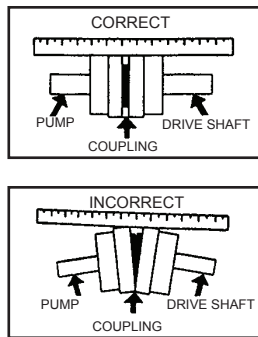

FIGURE 5

FLEXIBLE COUPLINGS CHART VI-A

COUPLING PART NUMBER	POWER UNIT SHAFT DIAMETER	PUMP SHAFT DIAMETER	ELECTRIC MOTOR FRAME SIZES
787-01	1.125"	.75"	182T-184T
2051-01	1.125"	1.125"	182T-184T
2052-01	1.375"	1.125"	213T-215T

****BASEPLATE KITS**

These kits contain a baseplate, coupling guard, shims and hardware for mounting a pedestal pump to the power units listed. All necessary mounting holes are provided.

KIT 58-0116 - This kit is suitable for use with motors having the following frame sizes: 182T, 184T and 213T, for 2" pumps.

KIT 58-0117 - This kit is suitable for use with motors having the following frame sizes: 184T, 213T and 215T, for 3" pumps.

B. Pedestal Pump Dimensions

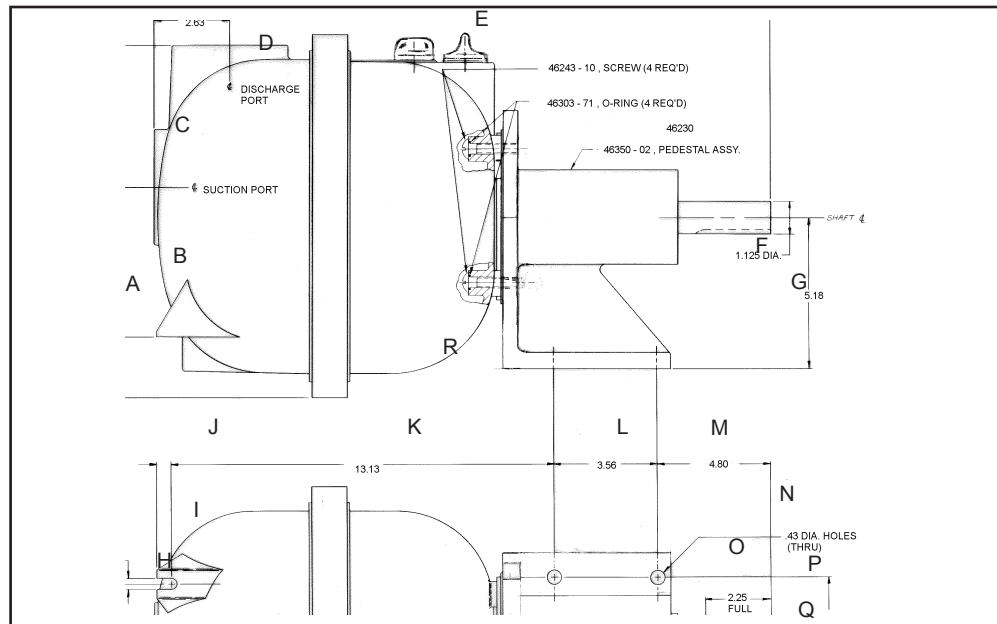
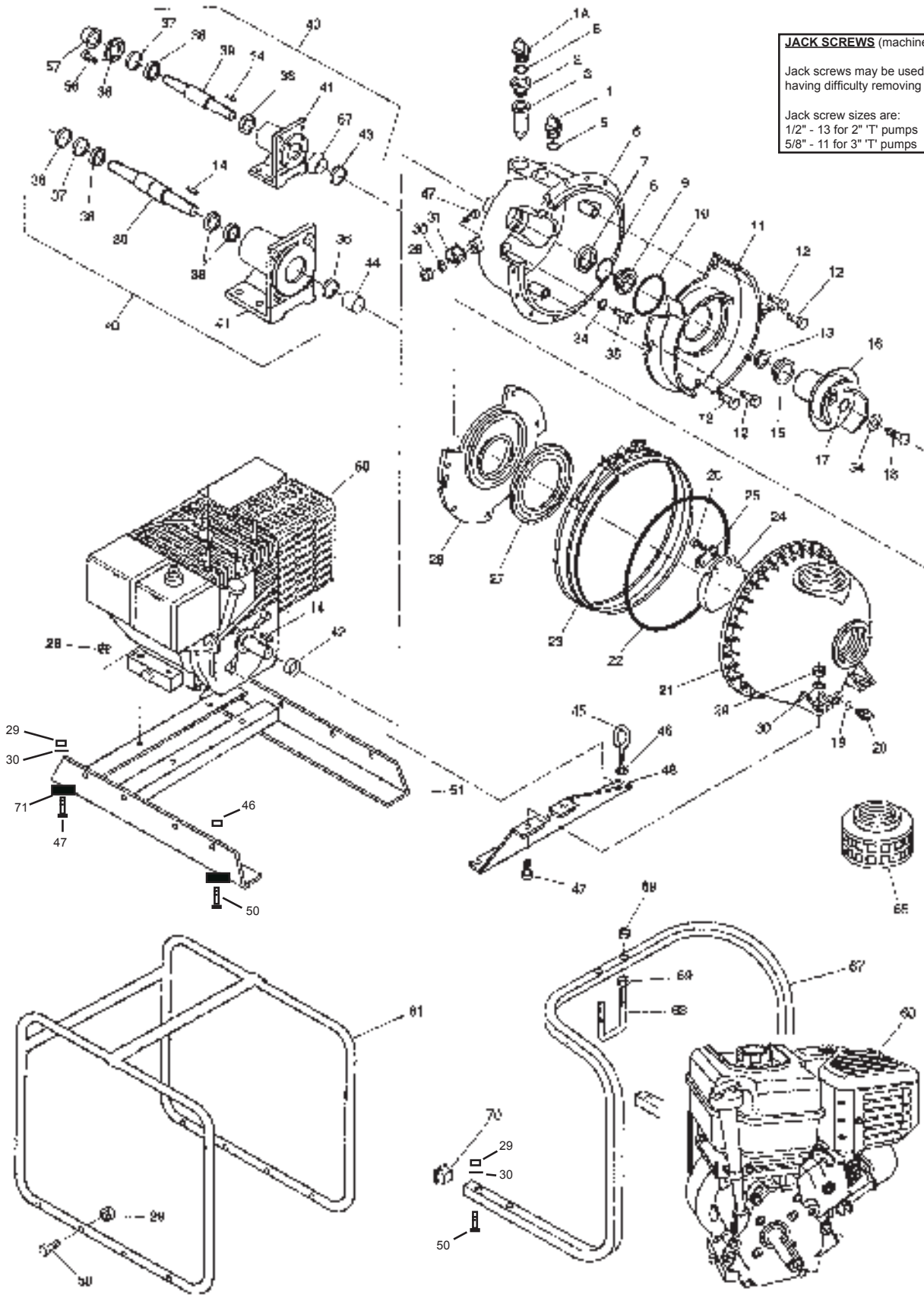

FIGURE 4

Pump Size	A	B	C	D	E	F	G	H	I	J	K	L	M	N	O	P	Q	R
2"	7.12	5.17	4.85	2.63	16.40	.75	4.17	2.625	.375	.492	10.95	2.25	2.58	.34	1.12	1.61	.094	1.0
3"	7.12	5.17	4.90	2.63	22.19	1.122	5.36	2.625	.375	.492	13.13	3.56	4.94	.44	2.50	2.875	.125	1.0

All dimensions are in inches.

SELF-PRIMING CENTRIFUGAL "T" PUMP EXPLODED VIEW PARTS DIAGRAM



"T" PUMP PARTS LIST

*All parts may be used for either 2" or 3" pumps unless specifically designated otherwise.

PUMP				PUMP					
ITEM #	SIZE*	PART #	PART DESCRIPTION	QTY./	ITEM #	SIZE*	PART #	PART DESCRIPTION	QTY./PUMP
PUMP									
1		58-0722 30B	PLUG, Filler, Polyester	1	28	2"	58-46225 91	WEARPLATE, Rubber coated with Steel core	1
1A		58-0722 30B	PLUG Filler, Oil Lube, Polyester	1					
2		58-46294 30	RETAINER Lube Tube	1	3"	58-46205 91	WEARPLATE, Rubber coated with Steel core	1	
3		58-46215 71	TUBE, Lubrication, Buna-n	1	29		58-0745	KEPNUT, 5/16"-18, plated steel as req'd	
5		58-0765 71	O-RING, Filler Plug, Buna-N	2	30		58-0730	WASHER, flat, 5/16", plated steel, Engine drive only	as required
6	2"	58-46218 31B	BRACKET Assy, Includes Items 1, 1A, 2, 3, 5, 6, 7, 8, 9	1	31		58-46274	HOLDER, Spanner Wrench, Steel	1
	2"	58-46218 30B	BRACKET ONLY	1	34	2"	58-0717 71	O-RING, Bracket screw, Buna-N	4
	3"	58-46208 31B	BRACKET Assy, Includes Items 1, 1A, 2, 3, 5, 6, 7, 8, 9	1		3"	58-46303 71	O-RING, Bracket screw, Buna-N	4
	3"	58-46208 30B	BRACKET ONLY	1	35	2"	58-0715 10	SCREW, Bracket, 5/16"-24 x 1-1/4" S.S.	4
7	2"	58-46314 11	SEAL, Oil Lip	1		3"	58-46308 10	SCREW, Bracket, 3/8"-16 x 1-3/4" S.S.	4
	3"	58-46313 11	SEAL, Oil Lip	1	36	2"	58-1953 10	END PLATE, Stainless Steel	1
8	2"	58-0976 71	O-RING, Shaft Seal, Buna-N	1		3"	58-46354	RING, Snap, Retaining, Steel	2
	3"	58-46307 71	O-RING, Shaft Seal, Buna-N	1	37	2"	58-1956 10	SHIM, Stainless Steel	as required
8, 9	2"	58-46250 11	SEAL, Shaft, Stainless Steel	1		3"	58-46353 10	SHIM, Stainless Steel	as required
& 15			Siliconized Graphite, Buna-N	1	38	2"	58-1954 90	BEARING	2
	3"	58-46251 11	SEAL, Shaft, Stainless Steel, Silicon Carbide, Buna-N	1		3"	58-46372 90	BEARING, for 58-46350 03 Ped. Assy.	3
10	2"	58-1203 71	O-RING, Volute, Buna-N	1	39	2"	58-1952 10	SHAFT, 3/4" diameter, Stainless Steel	1
	3"	58-46292 71	O-RING, Volute, Buna-N	1		3"	58-46371 10	SHAFT, 1" x 1-1/8" diameter, Stainless Steel for 58-46350 03 ped assy.	1
11	2"	58-46224 80	VOLUTE, Urethane coated with Steel core	1	40	2"	58-1950 03	PEDESTAL ASSY, includes items 36, 37, 38, 39, 41, 43, 56 & 57 (3/4" shaft)	1
	3"	58-46204 80	VOLUTE, Urethane coated with Steel core	1		3"	58-46350 03	PEDESTAL ASSY, includes items 36, 37, 38, 39, 41 & 44 (1" shaft)	1
12	2"	58-46269 10	SCREW, Button Head 1/4"-20 x 1" Stainless Steel	2	41	2"	58-1951 90	HOUSING, bearing pedestal, for 3/4" shaft	1
	3"	58-46269 10	SCREW, Button Head 1/4"-20 x 1" Stainless Steel	4		3"	58-46373 90	HOUSING, bearing pedestal for 58-46350 03 Pedestal Assembly	1
13	2"	58-0778 11	SHIM, Impeller, .006" S.S.	as required	42	2"	58-0884 71	SLINGER, for 3/4" shaft	1
	2"	58-0778 12	SHIM, Impeller, .015" S.S.	as required		3"	58-46266 71	SLINGER, for 1" shaft	1
	2"	58-0778 13	SHIM, Impeller, .030" S.S.	as required	43	2"	58-46219 10	SLEEVE, for 3/4" shaft, Stainless Steel	1
	3"	58-46338 10	SHIM, Impeller .015" S.S.	as required	44	3"	58-46359 10	SLEEVE, for 1" shaft, s.s., pedestal only	1
14	2"	58-46339	KEY, 3/16" x 11/16" long, steel	1	45	2"	58-46279	BOLT, eye, plated steel	2
	3"	58-46278	KEY, 1/4" x 1" long, steel	1		3"	58-2167	SCREW, 5/16"-18 x 1 1/2", plated steel	2
16	2"	58-46229 80	IMPELLER, Urethane coated with Steel core	1	46		58-46280	NUT, flange, 5/16"-18, plated steel	2
	2"	58-46229 81	IMPELLER Assy, as above but with siliconized graphite seal half installed	1	47		58-0729	SCREW, 5/16"-18 x 1", plated steel	as required
	2"	58-46229 90	IMPELLER, Molded, Polymar 656	1	48	2"	58-46306	SUPPORT, Front housing, 17" long, Painted steel	1
	2"	58-46229 91	IMPELLER Assy, Molded Polymar 656 with siliconized graphite seal half installed	1		3"	58-46365	SUPPORT, Front housing, 19-15/16" Long, Painted steel	1
	3"	58-46214 80	IMPELLER, Urethane coated with Steel core	1	50		58-2167	SCREW, 5/16"-18 x 1-1/2", plated steel	as required
	3"	58-46214 81	IMPELLER, Assy, as above but with silicon carbide seal half installed	1	51	2"	58-46310	CHASSIS, painted steel	1
	3"	58-46214 90	IMPELLER, Molded, Polymar 656	1		3"	58-46355	CHASSIS, painted steel, for Honda powered pump	1
	3"	58-46214 91	IMPELLER, Assy, Molded Polymar 656 with silicon carbide seal half installed	1		3"	58-46379	CHASSIS, painted steel, for Briggs & Stratton powered pump	1
17	2"	58-46291 71	O-RING, Impeller Screw, Buna-N All 2" & 3" Polymar 656 impellers	1	54	2"	58-46341	WASHER, Impeller screw, rubber coated	1
	3"	58-46290 71	O-RING, Impeller Screw, Buna-N Urethane coated 3" impellers only	1	56	2"	58-2525 10	SCREW, hex, 1/4"-20 x 3/4", Stainless	4
18	2"	58-0715 10	SCREW, Impeller, 5/16"-24 x 1-1/4" Stainless Steel	1	57	2"	58-1955 71	LIP SEAL, Buna-N	2
	3"	58-46309 10	SCREW, Impeller, 7/16"-20 x 1-1/4" Stainless Steel	1	60			ENGINE, consult factory w/model number	1
19		58-1009 71	O-RING, Drain plug, Buna-N	1	61	3"	58-46254	ROLL CAGE, for 3" "T" pump	1
20		58-0723 30	PLUG, Drain, Polyester	1	65	2"	58-46286 RH	STRAINER, Suction, Plated Steel	1
21	2"	58-46252 31B	BODY Assy, Includes items 19, 20, 24, 25, 26, 27 and the body	1		3"	58-46287 RH	STRAINER, Suction, Plated Steel	1
	2"	58-46252 30B	BODY ONLY	1	67	2"	58-2035	CARRYING HANDLE, for 2" "T" pump	1
	3"	58-46207 31B	BODY Assy, Includes items 19, 20, 24, 25, 26, 27 and the body	1	68	2"	58-2036	U BOLT, 3/8-16, Plated Steel	1
	3"	58-46207 30B	BODY ONLY	1	69	2"	58-2037	HEX NUT, 3/8-16, Plated Steel	4
22		58-46304 71	O-RING, Body, Buna-N	1	70	2"	58-0726 90	FINISHING CAP, Plastic	2
23		58-46305 10	CLAMP, V-Band, Stainless Steel	1	71	2"	58-0727 90	RUBBER FEET	4
24		58-46217 71	VALVE, Check, Buna-N	1		3"	58-46378 90	RUBBER FEET	4
25		58-46344 30	RETAINER, Check valve, Polyester	1					
26		58-1348 10	SCREW, check valve retainer, #10-14 x 3/4" self-tapping, Stainless Steel	2					
27		58-46206 71	GASKET, Suction, Buna-N	1					

<u>Part No.</u>	<u>Description</u>
58-0206	2" hose with Camelot connections
58-0208	3" hose with Camelot connections

<u>Part No.</u>	<u>Description</u>
58-0204	2" hose with threaded connections
58-0207	3" hose with threaded connections

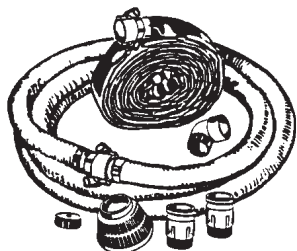

Kit includes: 20 ft. PVC Suction Hose, 25 ft. PVC Discharge Hose, Steel Pipe Nipples & Aluminum/Brass Swivel Nuts or Camelot Polypropylene Quick-Connect Couplings, Polypropylene Street Elbow, Polyethylene Suction Strainer, and a Roll of Teflon Tape to seal connections.

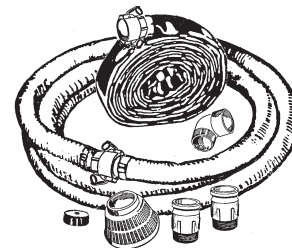

LIMITED 1 YEAR WARRANTY

Pacer Pumps warrants its products to be free from defects of material and workmanship for a period of one year (12 months) of service. If the one year of service falls within 24 months from date of manufacture. The company warrants that its products at the time of shipment, will be free of defects of material and workmanship for normal use and service. This warranty will not apply or be extended to products subject to misuse, neglect, accident, or improper installation, or to maintenance of products which have been altered or repaired by anyone except Pacer Pumps or its authorized representatives. The Buyer, or any person receiving such a product during the duration of the warranty, shall contact his Pacer Pumps dealer as soon as any defect occurs. Contact Pacer Pumps for the name and address of your nearest dealer.

Certain components such as mechanical seals, ceramic liners, impellers, impeller magnet assemblies, pistons, hose, diaphragms, etc. may be subject to wear, and therefore, wear should not be misconstrued as to the existence of a defect and as such would not be included in a warranty claim, nor should it be implied that items such as this will last a year without occasional, or even frequent replacement depending upon the severity of the application.

Pacer Pumps sole obligation under the foregoing warranty shall be limited to (at its option) repair and replacement (and reship to the Buyer with transportation charges collect to any place in the U.S.) of defective goods provided that if the company is unable to correct a defective component

part or product, the Buyer shall be entitled to elect a credit at the original buyer's purchase price. To return a DEFECTIVE PUMP, to return any parts for credit, or to obtain service

information, contact the Service Department. After receiving permission to return merchandise, the Buyer is authorized to return the product to Pacer Pumps, freight prepaid. If the company determines that the warranty has not been breached, product will be repaired or replaced free of charge.

The company will not be responsible for any damage or losses, direct or indirect, arising from any cause whatsoever, nor for damage to equipment caused by outside influences including improper installation or modification, improper voltage supply, lightning, corrosive liquids, abrasive liquids, or careless handling, nor for labor, transportation or other damages incurred in the replacement or repair of defective parts. In these cases, repair will be subject to recondition charges in effect at the time.

Purchased merchandise, either as a complete product for resale, or components used in conjunction with Pacer Pumps manufactured products, carries the warranty of the respective manufacturer of such products or components.

This warranty supersedes any warranty previously in effect.

PACER® PUMPS

Div. of ASM Industries, Inc.

*servicing
industry
worldwide*

41 Industrial Circle
Lancaster, PA 17601
Email: sales@pacerpumps.com
Web: www.pacerpumps.com

717-656-2161
800-233-3861
FAX: 717-656-0477

<u>Part No.</u>	<u>Description</u>
58-0206	2" hose with Camelot connections
58-0208	3" hose with Camelot connections

<u>Part No.</u>	<u>Description</u>
58-0204	2" hose with threaded connections
58-0207	3" hose with threaded connections

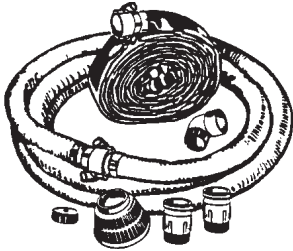

Kit includes: 20 ft. PVC Suction Hose, 25 ft. PVC Discharge Hose, Steel Pipe Nipples & Aluminum/Brass Swivel Nuts or Camelot Polypropylene Quick-Connect Couplings, Polypropylene Street Elbow, Polyethylene Suction Strainer, and a Roll of Teflon Tape to seal connections.

