

EXPLODED VIEW & PARTS LISTING

Model: NDP-500BSH  
 Model#: 855394

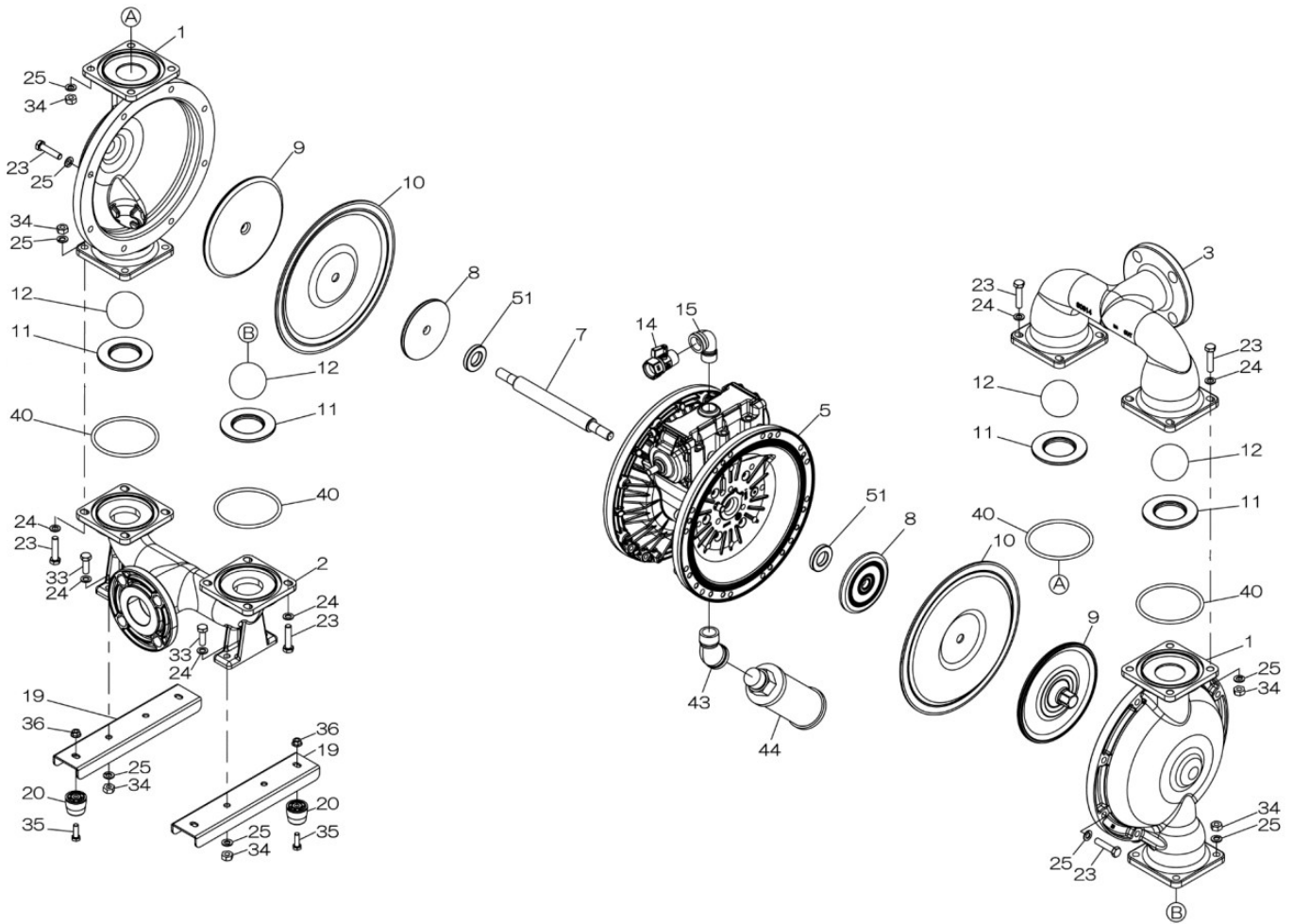

Air Operated Double Diaphragm Pump



Air Operated Double Diaphragm Pump

■Body Assembly

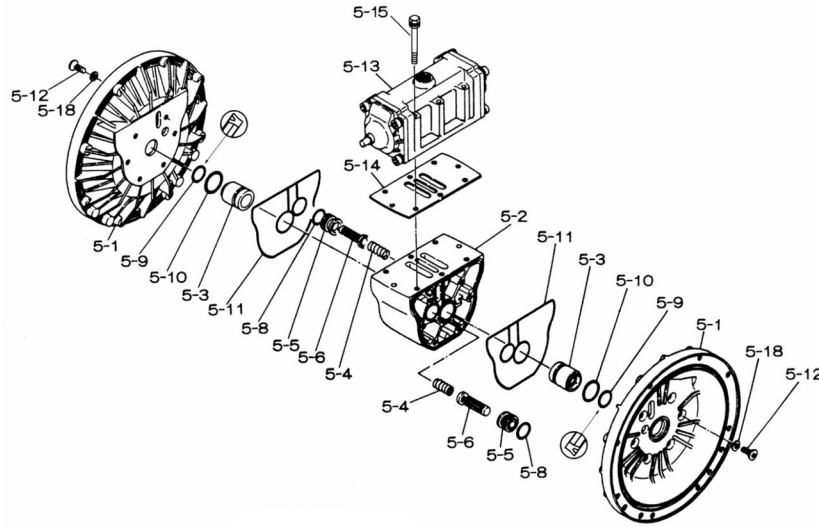

■Valve Body Assembly

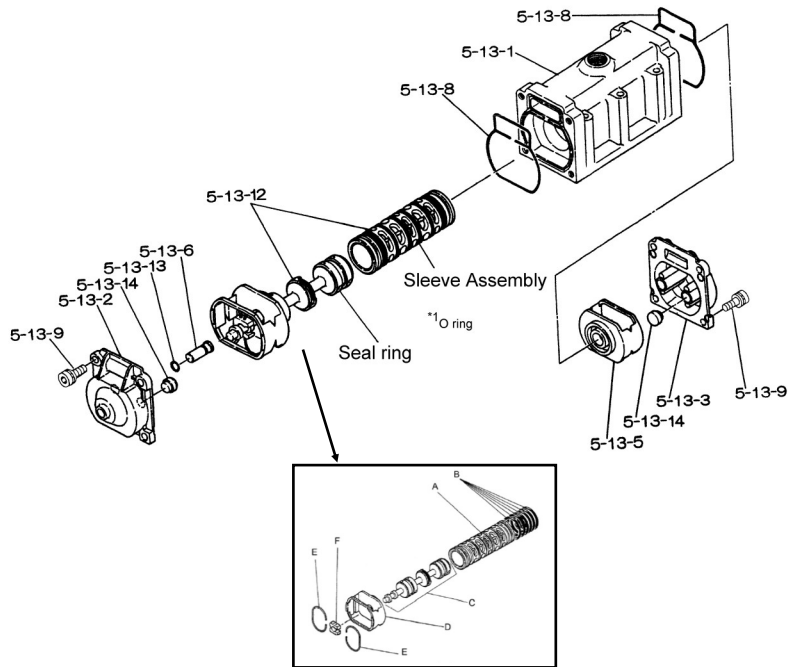

Air Operated Double Diaphragm Pump

REF. No.	PART No.	DESCRIPTION	QTY.
1	714449	OUT CHAMBER	2
2	717450	IN MANIFOLD FLG	1
3	717452	OUT MANIFOLD FLG	1
5	803112	BODY ASSY	1
5-1	711934	AIR CHAMBER	2
5-2	711936	BODY	1
5-3	780325	THROAT BEARING	2
5-4	711937	SPRING	2
5-5	771740	VALVE SEAT	2
5-6	832162	PILOT VALVE ASSY	2
5-8	640020	O RING	2
5-9	685444	PACKING	2
5-10	640029	O RING	2
5-11	771742	GASKET	2
5-12	683812	BOLT	12
5-13	802971	VALVE BODY ASSY	1
5-13-1	711931	VALVE BODY	1
5-13-2	580999	CAP A	1
5-13-3	581000	CAP B	1
5-13-5	771735	SPRING RETAINER	1
5-13-6	712976	RESET BUTTON	1
5-13-8	771738	GASKET	2
5-13-9	685036	BOLT	8
5-13-12	805084	C SPOOL ASSY	1
5-13-13	640005	O RING	1
5-13-14	684128	CUSHION	4
5-14	771712	GASKET	1
5-15	684240	BOLT & WASHER	6
5-18	684987	PLAIN WASHER	12
7	711900	CENTER ROD	1
8	711904	CENTER DISK	2
9	717438	CENTER DISK	2
10	771703	DIAPHRAGM	2
11	771794	VALVE SEAT	4
12	773143	BALL	4
14	686974	VALVE	1
15	682523	ELBOW	1
19	711928	BASE	2
20	771402	RUBBER FOOT	4
23	621180	BOLT	32
24	631174	PLAIN WASHER	20
25	631937	WAVE WASHER	36
33	621175	BOLT	4
34	687295	NUT	20
35	611149	BOLT	4
36	682276	FLANGED NUT	4
40	640069	O RING	4
43	685716	ELBOW	1
44	685700	MUFFLER	1
51	770582	CUSHION	2
KIT	K500-MH	LIQUID KIT	
KIT	K45-AM	AIR MOTOR KIT	

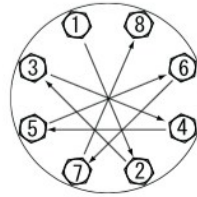

[CLICK HERE FOR TORQUE](#)



**General Tools:**

- Socket wrenches - 13mm, 17mm, 19mm, 24mm
- Hexagonal box wrench - 5mm, 6mm
- Small crowbars - 2 (C/N/E/V)
- Open-end wrenches - 19mm, 24mm
- Plastic hammer

**Special Tools (sold separately):**

- Sleeve remover (713180).

**Miscellaneous:**

- Nuts - M16 x 1.5
- Thread locker
- Urea grease grade (NLGI) No. 2 for Center Rod (Ref# 7)

[CLICK HERE FOR MAINTENANCE MANUAL](#)

**Customer Notes**

Model #: \_\_\_\_\_  
 Description: \_\_\_\_\_  
 Serial #: \_\_\_\_\_  
 Date Installed: \_\_\_\_\_  
 Department Location: \_\_\_\_\_  
 Tag/Project: \_\_\_\_\_