



Questions? Call **1-800-810-1053**

Please read and save this Repair Parts Manual. Read this manual and the General Operating Instructions carefully before attempting to assemble, install, operate or maintain the product described. Protect yourself and others by observing all safety information. The Safety Instructions are contained in the General Operating Instructions. Failure to comply with the safety instructions accompanying this product could result in personal injury and/or property damage! Retain instructions for future reference. AMT reserves the right to discontinue any model or change specifications at any time without incurring any obligation.

©2015 AMT Pump Company, A Subsidiary of The Gorman-Rupp Company, All Rights Reserved.

Periodic maintenance and inspection is required on all pumps to ensure proper operation. Unit must be clear of debris and sediment. Inspect for leaks and loose bolts. Failure to do so voids warranty.

# Ryton and Polypropylene Rotary Drum Pumps



## DESCRIPTION

**Ryton® pump (4942-99)** is designed for the transfer of aggressive chemicals including many esters, ketones, alcohols, and hydrocarbons which are compatible with pump component materials\*.

**Polypropylene pump (4946-99)** is designed for the transfer of many organic acids, alcohols, and other water soluble inorganic chemicals which are compatible with pump component materials\*.

Both units are lightweight and feature versatile discharge spout which can be rotated 360° to suit needs. Includes 45" suction tube.

(\* Always refer to a chemical resistance chart to confirm compatibility. Not rated for food products.

## SPECIFICATIONS

Flow.....	6 GPM @ 70 RPM (11 oz./stroke)
Maximum Liquid Temperature.....	180° F (4942-99)
	130° F (4946-99)
Mounting.....	2" NPS Bung Adapter
Inlet.....	1-1/4" -16 Unified
Outlet.....	1" -16 Unified
Weight.....	5 lbs.
Basic Construction (body, covers, and suction tube assembly)	
4942-99.....	Ryton® (PPS)
4946-99.....	Polypropylene (PP)
Rotor, Vanes, and Rods.....	Ryton® (PPS)
Spring.....	Stainless Steel
Seals.....	Teflon®

## GENERAL SAFETY INFORMATION

### ▲ WARNING

*It is the responsibility of the user to operate the pump in conformance with OSHA rules for dispensing liquids. Pump containers should be grounded when using with flammable liquids to avoid static electricity. Pump should be washed out before usage since processing lubricants could contaminate the fluid.*

- When using a hand pump (especially when pumping flammable, combustible or hazardous liquids) follow all electrical and safety codes, as well as the United States Occupational Safety and Health Act (OSHA), most recent National Electrical Code (NEC), National Fire Protection Association, Inc.\* (NFPA) Code 30 (Flammable and Combustible Code), NFPA 56A (Standard for use of Inhalation Anesthetics), NFPA 77 (Static Electricity), NFPA 78 (Lighting Protection Code), NFPA 80 (Standard for Fire Doors and Windows), NFPA 251 (Standard Method of Fire Test of Building Construction), NFPA 704 (Identification of the Fire Hazards of Materials), other NFPA codes, local codes and ordinances, as needed in a particular application.
- Know the pump application, limitations, and potential hazards. The WARNING statements indicate potentially hazardous conditions for the operator or equipment. TAKE NECESSARY STEPS TO PROTECT PERSONNEL AND EQUIPMENT.

Pump should only be used with liquids compatible with pump component materials. Consult PUMP CHEMICAL COMPATIBILITY CHART and PUMP SPECIFICATIONS. Also, the chemical supplier should be consulted regarding any questions of chemical compatibility, proper and safe use and handling of chemical. Misapplication of pump or use of incompatible liquids will void warranty.

### ▲ WARNING

*In order to properly use this product familiarize yourself with this pump and also with the liquid (chemical, etc.) that is going to be pumped through the unit. Although this pump is suitable for many liquids, it is not suitable for all liquids or liquids with debris or solids!*

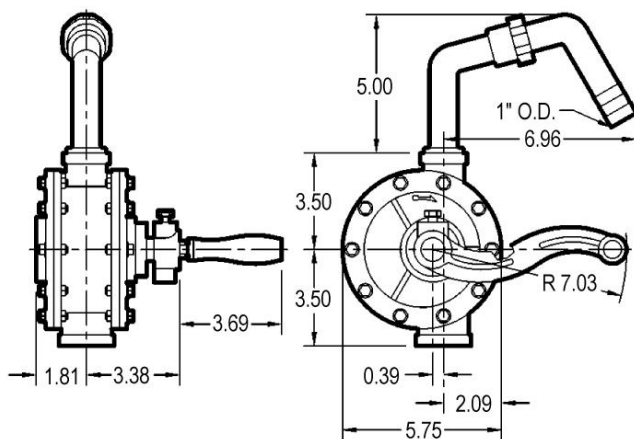

Figure 1 – Dimensions (Inches)

## UNPACKING

When unpacking the unit, inspect carefully for any damage that may have occurred during transit.

Check for loose, missing, or damaged parts. Transit damage claims should be made to the shipping company.

# Ryton and Polypropylene Rotary Drum Pumps

3. Pumping hazardous, flammable, or combustible liquids should only be done in buildings, rooms, or areas suited for this purpose. (See NFPA 30, NFPA 78, NFPA 80, NFPA 251, NFPA 704, other suitable NFPA codes, OSHA, insurance companies, local codes and ordinances.)

## ▲ WARNING

*When filling cans, drums, etc. with combustible or flammable liquids, both containers (container pumping from and container pumping to), should be bonded and grounded to dissipate possible accumulations of static electricity and minimize sparks caused by static electricity. (Refer to NFPA 77 for specifics and further details.) Removal of outer garments in work areas where there may be flammable or explosive liquids, which are ignitable with low electrical energy can be fatal and/or cause property damage. (Refer to NFPA 56A and NFPA 77 for further details.)*

4. The WARNING and instructions that follow pertain not only to gasoline, but to any flammable, combustible or hazardous fluid.

## ▲ WARNING

*Gasoline is a highly flammable fuel. The improper use, handling, or storage of gasoline can be dangerous. Prevent accidents by following these safety rules.*

- Use gasoline only as fuel, never as a cleaning fluid.
- Use only an approved container to hold or store gasoline. Never store gasoline in familiar containers such as milk containers or soda pop bottles.
- Store gasoline in a cool location, out of the reach of children. Never store gasoline near heat or an open flame.
- Provide a fire extinguisher nearby when working with gasoline. Be sure extinguisher is in operating condition – check the pressure gauge of indicator. Be familiar with its proper use. Consult local fire department for the correct type of extinguisher for your application. Extinguishers rated ABC by the National Fire Protection Association are appropriate for most applications.
- Provide positive shut-off valves on all permanent fuel supplies. Fuel lines must be of steel piping, adequately secured, and free from leaks.
- Provide adequate ventilation, and clean up any spills when handling or pumping flammable liquids.
- POSITIVELY NO SMOKING!**
- Do not use torches or apply fire to this pump for any reason.
- Secure the discharge line before starting the pump. An unsecured discharge line will slip, possibly causing personal injury and/or property damage.
- Do not over tighten nonmetallic, threaded fittings. One full turn past hand tight is usually enough to prevent leakage. Teflon® sealant tape is provided and should be used on all threaded joints, including the spout.
- Check hoses for weak or worn conditions before each use, making certain that all connections are secure.
- Periodically inspect pump and system components. Perform routine maintenance as required.
- Drain all liquids from the system before servicing.

## ▲ WARNING

*Any pump used to transfer flammable liquids must be stored in a well-ventilated area after use.*

## PERSONAL SAFETY

- Wear safety glasses at all times when working with pump.
- Wear a face shield, proper apparel and suitable respiratory equipment when pumping hazardous chemicals.
- Keep work area clean, uncluttered, and properly lighted. Replace all unused tools and equipment.
- Keep visitors at a safe distance from the work area.
- Make workshop childproof with padlocks, master switches, and by removing starter keys.

## ▲ WARNING

*Failure to follow all General Safety Information can result in a fatality, personal injury and/or property damage!*

## ASSEMBLY AND INSTALLATION

(Refer to Figure 1)

- Screw bung adapter (Ref. No. 3) into drum with threaded end down.
- Screw spout (Ref. No. 1) into pump casing (Ref. No. 2).
- Screw suction tube (Ref. No. 4) into base of pump casing. Use Teflon® Sealant tape provided.
- Insert pump assembly into drum through bung adapter and tighten butterfly screw by hand. Do not use wrench or tool to tighten butterfly screw.

## ▲ CAUTION

*Not for use with water or other liquids that may cause corrosion.*

## Assembly and Installation

(Refer to Figure 2)

- Remove one hex nut from handle shaft and place it into hex indent of crank arm (Ref. No. 10).
- Finger-tighten remaining nut against handle.
- Feed shaft through crank arm, then thread into hex nut. When shaft is fully threaded, use wrench to tighten hex nut.

**NOTE:** Handle should spin freely on shaft when properly assembled.

- Place crank arm assembly onto rotor shaft (Ref. No. 3). Align fastener with indent on shaft before tightening. Do not over tighten!
- Assemble discharge spout (Ref. No 5) and screw into casing (Ref. No 4). Union provided in spout allows tip to be rotated 360° depending on dispensing needs.

**IMPORTANT:** All threaded pipe connections must be airtight in order for pump to prime and work properly. Use Teflon® tape (provided) on all connections. Do not over tighten.

- Assemble suction tube (Ref. No. 12) and attach strainer (Ref. No 13).
- Place bung adapter assembly (Ref. No. 7) over suction tube with threaded end facing down. Then connect suction tube assembly to base of pump casing.
- Insert pump assembly into drum and tighten bung adapter. Tighten thumb screw by hand. Do not use wrench or tool to tighten thumb screw.

## OPERATION

- Rotate handle rapidly several times in a clockwise direction to prime. If pump does not prime, refer to "Troubleshooting Chart" section.

## MAINTENANCE

Periodically inspect the pump assembly and suction tubes for weak or worn condition. Make certain that all connections and fasteners are tight and secure. Perform routine maintenance as required.

## Troubleshooting Chart

Symptom	Possible Cause(s)	Corrective Action
Pump does not prime	<ol style="list-style-type: none"> <li>Suction line above liquid</li> <li>Pump speed too slow</li> <li>Unsuitable suction line</li> <li>Clogged suction line and/or filter</li> <li>Suction line air leakage</li> <li>Cover air leakage</li> <li>Shaft air leakage</li> <li>Housing air leakage</li> <li>Shifted or worn rotor</li> <li>Damaged/worn pump parts</li> </ol>	<ol style="list-style-type: none"> <li>Ensure that open end of suction line remains completely below surface of liquid</li> <li>Operate pump handle rapidly until pump primes (up to 30 cycles)</li> <li>Pumps are intended for use with suction line supplied. Longer or collapsible suction line may prohibit priming. Use short length rigid line similar in diameter to suction port. (Maximum pump height above liquid 36")</li> <li>Clean suction line and/or filter (where applicable)</li> <li>Verify that all suction line connections are sealed tightly. Use Teflon® tape or appropriate sealant if necessary</li> <li>Inspect pump cover(s) for looseness and damaged or slipped gaskets. Replace damaged gaskets and snug-up cover(s)</li> <li>Verify shaft seal is properly seated and in good condition. Replace seal if worn or damaged</li> <li>Inspect entire pump housing, cover(s), and shaft for cracks. Replace damaged parts</li> <li>Loosen all cover bolts. View pump from side with suction/discharge ports in vertical position and on right hand side. Reposition rotor by grasping covers and sliding towards 3 o'clock position. Do not use excessive force. Hold in position and re-tighten cover bolts</li> <li>Remove pump cover and inspect for broken pieces. Components should have smooth finish, no large grooves or voids. Replace damaged parts. Piston type pumps may include a poppet valve which is designed to prevent back-flow. If excessive leakage past valve is found, replace valve (some leakage is normal)</li> </ol>
Handle difficult or impossible to move	<ol style="list-style-type: none"> <li>Pump has not been used for some time</li> <li>Damaged/worn pump parts</li> <li>Corroded pump parts</li> <li>Damaged/worn gear drive parts</li> </ol>	<ol style="list-style-type: none"> <li>Remove pump cover and inspect for crystallized, solidified, or gummy remains. Clean parts. To prevent future occurrences, flush pump with appropriate solvent after pumping problem liquid</li> <li>Remove pump cover and inspect internal parts. Components should have smooth finish, no large grooves or voids. Replace damaged parts</li> <li>Remove pump cover and inspect for corrosion. Clean parts and use pump only for liquids which are compatible with pump component materials</li> <li> <ol style="list-style-type: none"> <li>Remove oil plug from gear case and verify oil level is correct, top-up if necessary. See "Maintenance" for proper lubricant</li> <li>If pump is still difficult to turn, drain gear oil and inspect oil for contaminants indicating damaged gears. Replace damaged parts</li> </ol> </li> </ol>
Insufficient flow	<ol style="list-style-type: none"> <li>Clogged, collapsed, or undersized filter, suction and/or discharge line</li> <li>Also see above "Pump does not prime"</li> </ol>	<ol style="list-style-type: none"> <li>Pumps are intended for use with supplied rigid line and filter (where applicable). Verify line and filter are clean, not pinched closed, and of similar size of port connection</li> <li>Check and repair as necessary</li> </ol>

Order Online: [www.PumpCatalog.com](http://www.PumpCatalog.com)

**For Repair Parts contact dealer where pump was purchased.**

Please provide following information:

-Model Number

-Serial Number (if any)

Part description and number as shown in parts list

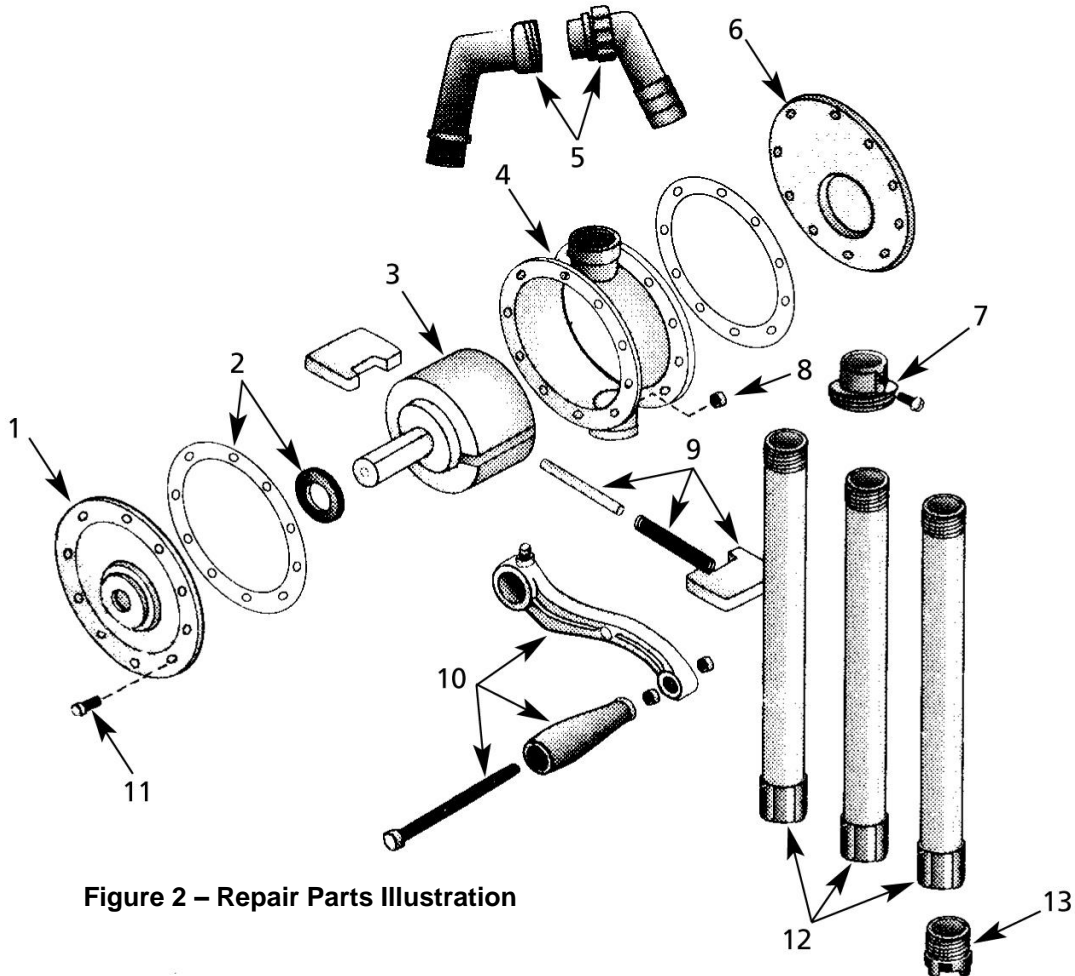

Figure 2 – Repair Parts Illustration

## Repair Parts List

Ref. No.	Description	Part Number for Models:		Qty.
		4942-99	4946-99	
1	Front Cover	N/A	N/A	1
2	Gasket and Shaft Seal Kit	4946-300-90	4946-300-90	1
3	Rotor	4946-140-00	4946-140-00	1
4	Casing	N/A	N/A	1
5	Discharge Spout Assembly	N/A	N/A	1
6	Rear Cover	N/A	N/A	1
7	Bung Adapter Assembly	4946-170-90	4946-170-90	1
8	Nut	*	*	20
9	Vane Kit	4946-010-90	4946-010-90	1
10	Crank Arm Assembly	4946-100-90	4946-100-90	1
11	Fastener	*	*	20
12	Suction Tube Assembly	N/A	N/A	1
13	Strainer	N/A	N/A	1

(\*) Standard Hardware Item, Available Locally

Order Online: [www.PumpCatalog.com](http://www.PumpCatalog.com)





AMT Pump Company  
(herein "AMT")  
400 Spring Street  
Royersford, PA 19468  
Phone: (610) 948-3800  
Fax: (610) 948-5300  
www.amtpump.com



## General Information

**SALES POLICY:** AMT products are sold through our established Distributors. We do not sell direct to the consumer or organization not entitled to trade recognition. Therefore, possession of our catalogs and/or price list(s) does not infer an offer to sell.

**MINIMUM ORDER:** We appreciate your order, however, all orders are subject to a minimum \$35.00 net invoice charge (excluding freight). This applies to all pump and parts purchase orders.

**PRICES:** Prices are subject to change without notice. All orders accepted are subject to prices in effect at time of shipment.

**PAYMENT TERMS:** Terms, upon establishment of credit, are Net 30 days. Past due accounts may be subject to a service charge of 1.5% per month. Domestic or assignable letter of credit is required for all export trade.

**PAST DUE ACCOUNTS:** AMT reserves the right to withhold open account shipments on any past due account. Invoices are considered past due after thirty (30) days. In the interest of sound business, all orders are subject to approval of the Credit Department.

**SHIPPING INSTRUCTIONS:** All shipments will be made F.O.B. the factory. Where instructions for shipment do not appear on the order, the shipment will be made according to our best judgment. Full risk of loss (including transportation delays and losses) shall pass to the customer upon delivery of the products to the carrier at the F.O.B. point. When loss or delay occurs, primary responsibility for tracing rests with the customer. When there is LOSS or APPARENT VISIBLE DAMAGE to a shipment, when tendered for delivery, **DO NOT** give the carrier a clear receipt. Note such damage on the carrier's delivery receipt and **HAVE THE DRIVER SIGN THE RECEIPT.**

**PRODUCT REVISIONS:** AMT reserves the right to discontinue, change or improve its products or any portions thereof without being obligated to provide such a change or improvement for units sold and/or shipped prior to such a change or improvement.

**LEAD TIME:** Products designated "Quick Ship Product", also referred to as "QSP" will normally be shipped within 24 hours of receipt of a non-cancellable purchase order. Only limited quantities of "QSP" pumps are available.

**STANDARD LEAD TIME:** Lead time is two weeks for all non "QSP" product. AMT reserves the right to revise lead times as required due to availability of materials and all other causes beyond our control.

**VIP SHIPMENT:** Select AMT and IPT branded pumps are available for next day shipment for non-QSP (Quick Ship Products) items and subjected to a specific model surcharge per unit noted in the respective price book. Requires calling for availability, confirmation and a non-cancellable purchase order or credit card payment prior to shipment. The expedited shipping charges are an additional cost added separately from the VIP charges per item. AMT reserves the right to revise lead times as required due to availability of materials and all other causes beyond our control. QSP quantities are limited as determined by AMT.

ALL purchase orders must be submitted via hard copy sent to AMT customer service department by fax, EDI or e-mail.

**RETURN GOODS POLICY:** Goods shall not be returned without a return goods authorization number (RGA) issued by AMT customer service. The RGA number must be listed on the packing list. Only current model and part numbers with a valid date code may be returned (within one year from date of purchase). **A 20% restocking and packaging charge will apply to all returns. All shipping charges must be pre-paid. No exceptions.**

**ORDER CHANGES BY CUSTOMER:** Orders in process may not be changed except with written consent and may be subject to special charges.

## 12 Month Limited Warranty

### EXTENT AND DURATION OF LIMITED WARRANTY

**Coverage:** AMT Pump Company (herein "AMT") or IPT Pumps by Gorman-Rupp (herein "IPT") or Gorman-Rupp Industries Division of The Gorman-Rupp Company, Patterson, or the Gorman-Rupp Company (herein referred to as "G-R Unit") each individually warrants that its products and parts shall be free from defects in material and workmanship for twelve (12) months from the date of purchase by the original end user when installation is made and maintenance is performed in accordance with G-R Unit's recommendations. Wear and tear resulting from use and items normally consumed in use are not covered.

### EXCEPTIONS

( A ) This Limited Warranty shall not apply to mechanical seals in AMT or IPT pumps and the following products and parts: engines, motors, trade accessories and all other products, components, parts and materials not manufactured by the G-R Units. These items may, however, be covered by the warranties of their respective manufacturers. ( B ) This warranty does not extend to or apply to any unit which has been repaired or altered at any place other than by a G-R Unit, or by persons not expressly approved by a G-R Unit to make repairs or alterations, nor to any unit the serial number, model number or identification of which has been removed, defaced or altered. ( C ) This warranty does not extend to any product manufactured by a G-R Unit, which has been subjected to mis-use, neglect, accident, improper installation, or use in violation of instructions furnished by a G-R Unit. ( D ) Pump Kits: This warranty does not extend to any product sold by a G-R Unit unassembled as a Pump Kit. Pump Kits are warranted against defects in material and workmanship for 60 days from the date of shipment from a G-R Unit. Any Pump Kit parts deemed defective by a G-R Unit will be replaced free of charge within 60 days of shipment. Pump Kits are not returnable for credit.

### LIMITATIONS

**THE G-R UNITS' SOLE AND EXCLUSIVE WARRANTY WITH RESPECT TO THEIR PRODUCTS AND PARTS IS THIS LIMITED WARRANTY. THIS LIMITED WARRANTY IS IN LIEU OF ALL OTHER EXPRESS AND/OR IMPLIED WARRANTIES, INCLUDING IMPLIED WARRANTIES OF MERCHANTABILITY AND FITNESS FOR PARTICULAR PURPOSE.**

### EXCLUSIVE REMEDY AND DAMAGES

The sole and exclusive remedy for breach of this Warranty by a G-R Unit and the entire extent of its liability for such breach or for damages arising from the use of the products and parts covered under this Limited Warranty, shall be as follows:

- Repair or Replacement:** If inspection shows that any G-R Unit product or part covered under this Limited Warranty is defective in materials or workmanship, the G-R Unit shall repair or replace the defective or non-conforming product or part without charge, whichever the G-R Unit chooses. You must have properly maintained and used the product or part claimed to be defective in accordance with the maintenance schedule or manual, which comes with the product. No allowance will be made for labor, installation, removal, transportation or other charges incurred by you in connection with such repair or replacement.
- To obtain the above remedy:
  - Immediately notify the G-R Unit upon discovery of the claimed defect in materials or workmanship and provide the serial number or date code of the product and/or part(s) or provide the G-R Unit with the invoice or bill of sale referencing the product by no later than the expiration date of the warranty period.
  - The G-R Unit will advise whether inspection will be necessary and how whether repair or replacement will be made. If inspection by the G-R Unit is necessary, the pump or defective part must be sent freight pre-paid to the G-R Unit. Return shipment will be F.O.B. the G-R Unit's plant.
  - Return Goods Authorization Requirement:** No product will be accepted for return or replacement without the prior written authorization of the G-R Unit. Upon such authorization, and in accordance with instructions from the G-R Unit, the product will be returned to the G-R Unit, shipping charges prepaid by the Buyer.
- Damages:** The G-R Unit's liability for damages for breach of this Limited Warranty shall not exceed the amount of the purchase price of the product or part(s) in respect to which Such damages are claimed. **IN NO EVENT SHALL THE G-R UNITS BE LIABLE FOR INCIDENTAL, CONSEQUENTIAL OR SPECIAL DAMAGES FOR BREACH OF THIS LIMITED WARRANTY.**

Some states do not allow the exclusion or limitation of incidental or consequential damages, so the above limitation or exclusion may not apply to you. This Limited Warranty gives you specific legal rights, and you may also have other rights, which vary from state to state.



**A Gorman-Rupp Company**



BY

**GORMAN-RUPP®**

[www.amtpump.com](http://www.amtpump.com)