



BALDOR® • RELIANCE

Product Information Packet

EM7059T

20//15HP,3520//2930RPM,3PH,60//50HZ,256T

Part Detail							
Revision:	Q	Status:	PRD/A	Change #:		Proprietary:	No
Type:	AC	Prod. Type:	0936M	Elec. Spec:	09WGZ601	CD Diagram:	CD0005
Enclosure:	XPFC	Mfg Plant:		Mech. Spec:	09E270	Layout:	09LYE270
Frame:	256T	Mounting:	F1	Poles:	02	Created Date:	06-16-2010
Base:	RG	Rotation:	R	Insulation:	F	Eff. Date:	10-04-2016
Leads:	9#12					Replaced By:	
Literature:		Elec. Diagram:					

Nameplate NP1426XPSLEV	
NO.	[] CC 010A []
SER.	[]
SPEC.	09E270Z601G1
CAT.NO.	EM7059T
HP	20//15 T. CODE T3C []
VOLTS	230/460//190/380
AMPS	46/23//42/21
RPM	3520//2930
HZ	60//50 PH 3 [] CL F []
SER.F.	1.00 DES A [] CODE H []
RATING	40C AMB-CONT
FRAME	256T NEMA-NOM-EFF 91 []
USABLE AT 208V	PF 89 []
BLANK	[]

Parts List		
Part Number	Description	Quantity
SA198663	SA 09E270Z601G1	1.000 EA
RA186026	RA 09E270Z601G1	1.000 EA
37FN3002C02	EXFN, PLASTIC, 6.00 OD, 1.500 ID	1.000 EA
MJ5000A01	SEALANT, CHICO A COMPOUND	0.031 LB
09CB1000A01SP	CONDUIT BOX, MACH	1.000 EA
10XN3118K16	5/16-18 X 1' GRADE #5, STL, ZINC PLATE	4.000 EA
HW1001A31	LOCKWASHER 5/16, ZINC PLT .591 OD, .319 I	4.000 EA
WD1000B16	T&B CX70TN TERMINAL	1.000 EA
10XN2520K06	1/4-20 X 3/8" HX HD SCREW GRADE 5, ZINC P	1.000 EA
HW1001A25	LOCKWASHER 1/4, ZINC PLT .493 OD, .255 I	1.000 EA
09EP1700A01	FR ENDPLATE, MACH	1.000 EA
10XN3816K28	3/8-16 X 1.75 HEX HD CAP SCREW, GRADE 5	4.000 EA
HW1001A38	LOCKWASHER 3/8, ZINC PLT .688 OD, .382 I	4.000 EA
HW5100A08	W3118-035 WVY WSHR (WB)	1.000 EA
HA2002A05	SPACER, #208 BRG	1.000 EA
10XN2520K36	1/4-20 X 2.25" HX HD SCRW GRADE 5, ZINC P	4.000 EA
HW1001A25	LOCKWASHER 1/4, ZINC PLT .493 OD, .255 I	4.000 EA
09EP1707A01	PU ENDPLATE, MACH	1.000 EA
10XN3816K28	3/8-16 X 1.75 HEX HD CAP SCREW, GRADE 5	4.000 EA
HW1001A38	LOCKWASHER 3/8, ZINC PLT .688 OD, .382 I	4.000 EA
09FH1004A01	FAN COVER, MACH	1.000 EA
10XN2520K14	1/4-20 X .88 HEX GRD 5 (20001)	3.000 EA
HW1001A25	LOCKWASHER 1/4, ZINC PLT .493 OD, .255 I	3.000 EA
09CB1500A01SP	CONDUIT BOX LID, MACH	1.000 EA

Parts List (continued)		
Part Number	Description	Quantity
10XN2520K16	1/4-20 X 1" HX HD SCRW GRADE 5, ZINC P	6.000 EA
HW1001A25	LOCKWASHER 1/4, ZINC PLT .493 OD, .255 I	6.000 EA
HW2501G25	KEY, 3/8 SQ X 2.875	1.000 EA
LB1115N	LABEL,LIFTING DEVICE (ON ROLLS)	1.000 EA
LB1073	ALUM XP CAUTION LABEL	1.000 EA
HW4500A20	1/8NPT SL PIPE PLUG	2.000 EA
MJ1000A02	GREASE, POLYREX EM EXXON (USe 4824-15A)	0.080 LB
HW4500A20	1/8NPT SL PIPE PLUG	2.000 EA
HW2500A25	WOODRUFF KEY USA #1008 #BLOW CARBON STEE	1.000 EA
51XB1214A20	12-14X1.25 HXWSSLD SERTYB	1.000 EA
MG1025G05	WILKOFASST, 789.227, MED. GRAY CHAR. MET.	0.050 GA
85XU0407S04	4X1/4 U DRIVE PIN STAINLESS	6.000 EA
MN416A01	TAG-INSTAL-MAINT no wire (1000/bx) 11/14	1.000 EA
LB1119N	WARNING LABEL	1.000 EA
LC0145B01	CONNECTION LABEL	1.000 EA
NP1426XPSLEV	SS XP UL CSA-EEV CC CL-I GP-D	1.000 EA
40PA1005	PACKAGING GROUP, 09 STD	1.000 EA

AC Induction Motor Performance Data

Record # 53246 - Typical performance - not guaranteed values

Winding: 09WGZ601-R041	Type: 0936M	Enclosure: XPFC
-------------------------------	--------------------	------------------------

Nameplate Data				460 V, 60 Hz: High Voltage Connection	
Rated Output (HP)	20//15			Full Load Torque	29.6 LB-FT
Volts	230/460//190/380			Start Configuration	direct on line
Full Load Amps	46/23//42/21			Breakdown Torque	111 LB-FT
R.P.M.	3520//2930			Pull-up Torque	39.1 LB-FT
Hz	60//50	Phase	3	Locked-rotor Torque	49.6 LB-FT
NEMA Design Code	B	KVA Code	H	Starting Current	161 A
Service Factor (S.F.)	1			No-load Current	7.17 A
NEMA Nom. Eff.	91	Power Factor	89	Line-line Res. @ 25°C	0.47592 Ω
Rating - Duty	40C AMB-CONT			Temp. Rise @ Rated Load	76°C
				Locked-rotor Power Factor	29
				Rotor inertia	0.92 LB-FT ²

Load Characteristics 460 V, 60 Hz, 20 HP

% of Rated Load	25	50	75	100	125	150
Power Factor	58	78	86	89	90	90
Efficiency	88.9	92.2	92.4	91.7	90.7	89.2
Speed	3579.6	3561.5	3541.3	3519.5	3495.4	3467.8
Line amperes	9	13	17.7	22.9	28.6	35

Performance Graph at 460V, 60Hz, 20.0HP Typical performance - Not guaranteed values

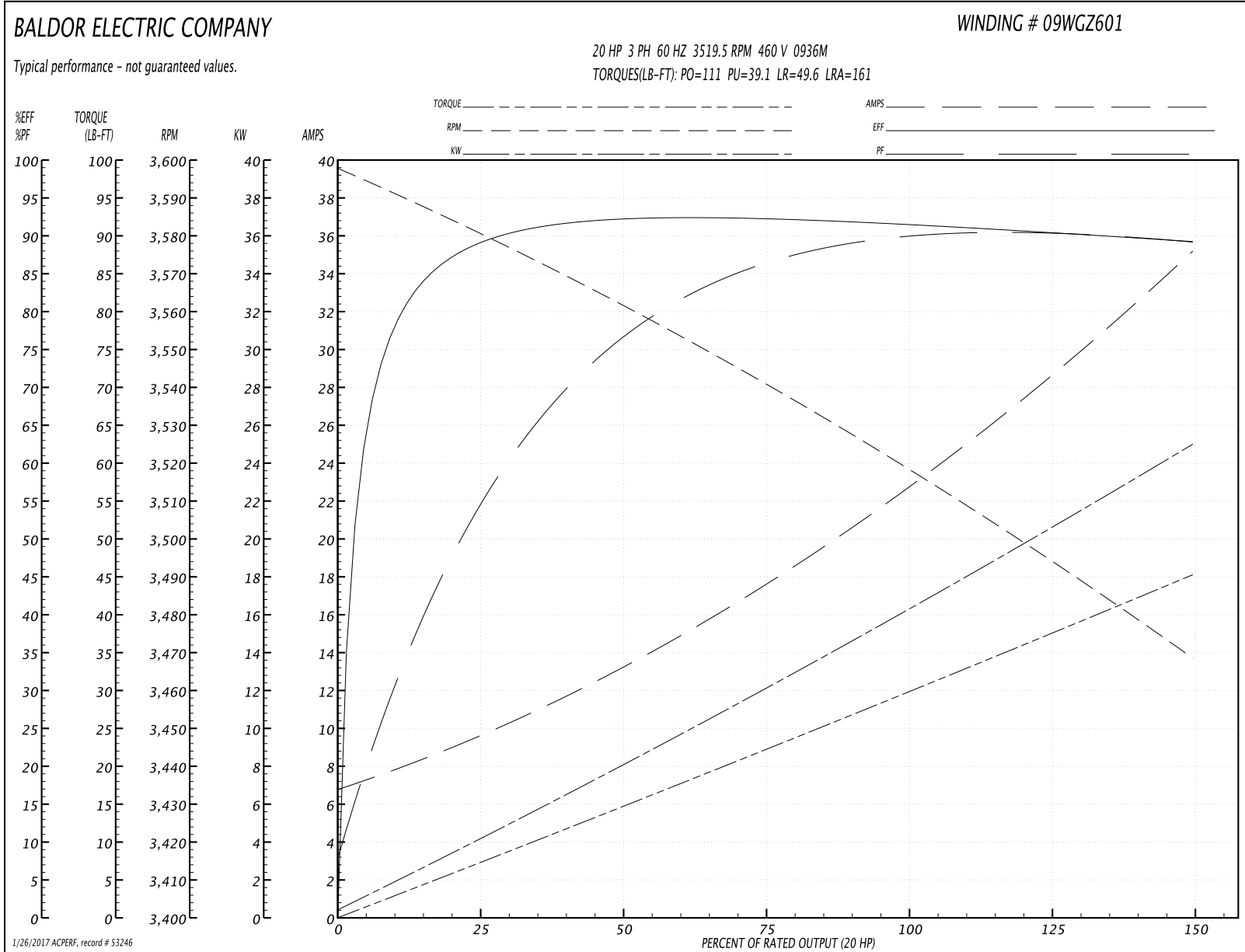

AC Induction Motor Performance Data
Record # 53247 - Typical performance - not guaranteed values

Winding: 09WGZ601-R041	Type: 0936M	Enclosure: XPFC
-------------------------------	--------------------	------------------------

Nameplate Data				380 V, 50 Hz: High Voltage Connection	
Rated Output (HP)	20//15			Full Load Torque	26.7 LB-FT
Volts	230/460//190/380			Start Configuration	direct on line
Full Load Amps	46/23//42/21			Breakdown Torque	106 LB-FT
R.P.M.	3520//2930			Pull-up Torque	41.4 LB-FT
Hz	60//50	Phase	3	Locked-rotor Torque	52.5 LB-FT
NEMA Design Code	B	KVA Code	H	Starting Current	157 A
Service Factor (S.F.)	1			No-load Current	6.99 A
NEMA Nom. Eff.	91	Power Factor	89	Line-line Res. @ 25°C	0.447 Ω
Rating - Duty	40C AMB-CONT			Temp. Rise @ Rated Load	67°C
				Locked-rotor Power Factor	33
				Rotor inertia	0.92 LB-FT ²

Load Characteristics 380 V, 50 Hz, 15 HP

% of Rated Load	25	50	75	100	125	150
Power Factor	55	76	85	88	90	90
Efficiency	88.8	92	92.1	91.3	90.2	88.7
Speed	2982	2966	2947	2928	2907	2882
Line amperes	8.55	12	16.3	21	26.1	31.8

Performance Graph at 380V, 50Hz, 15.0HP Typical performance - Not guaranteed values

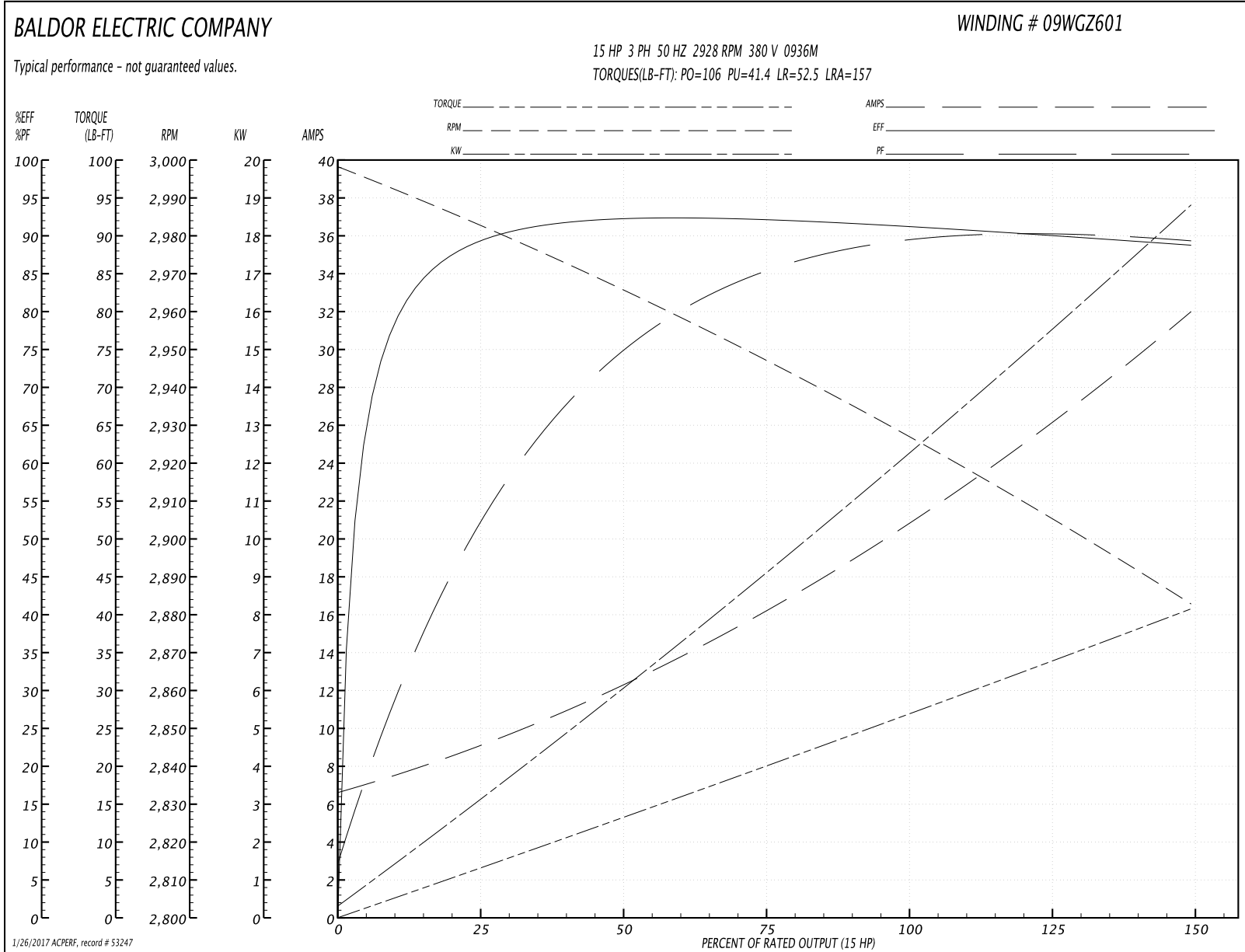

09LYE270

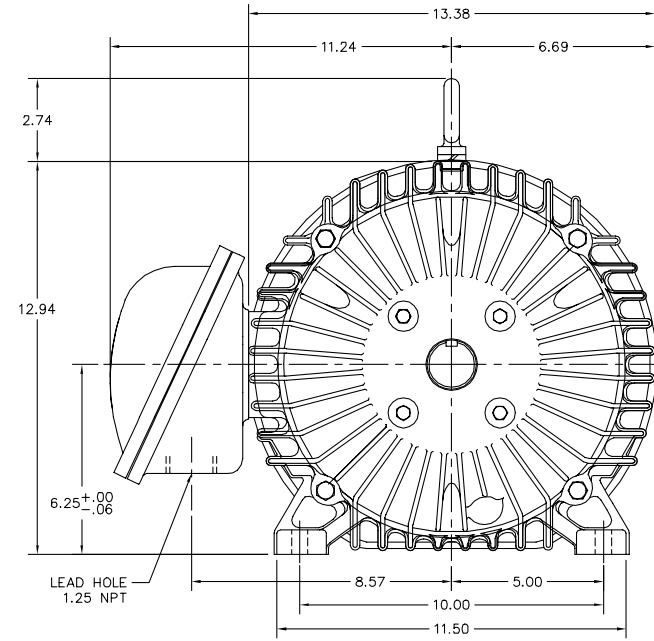
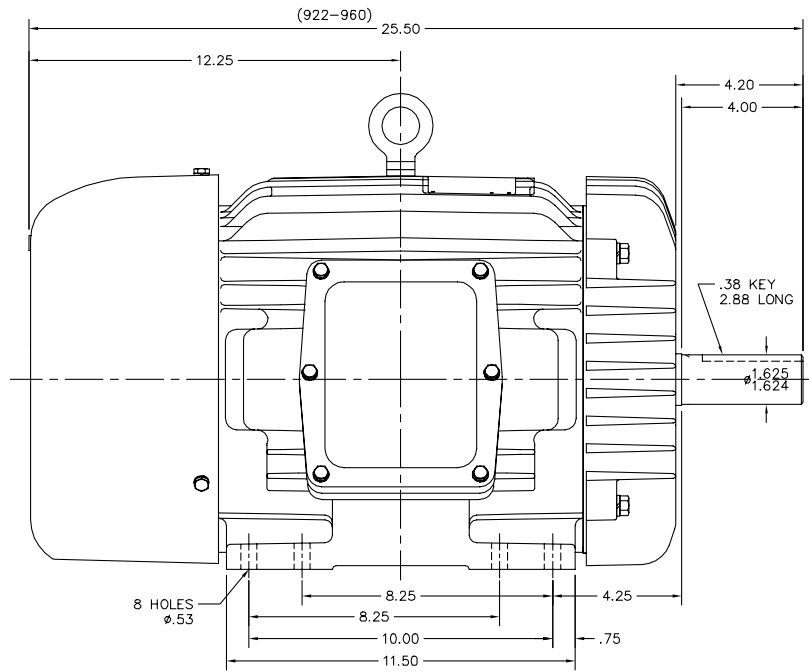

09LYE270

CUSTOMER IS RESPONSIBLE FOR DETERMINING THAT BALDOR'S PRODUCT WILL PERFORM SUITABLY IN THE INTENDED APPLICATION.

REV. DESC: UPDATED DESCRIPTION		
REV. LTR: G	VERSION: 04	TDR: 000000855922
FILE: \AAA\00000\626	REVISED: 08:34:04 05/30/2014	BY: ENNINDO
MTL: -		

BALDOR

HORZ XPFC 254-6T CL.I GP.D,CL.II GP.F&G
SH 1 of 1

CD0005



LOW VOLTAGE
(2Y)



LINE

HIGH VOLTAGE
(1Y)

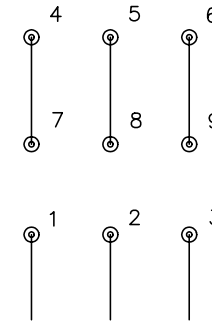

LINE

NOTES:

1. INTERCHANGE ANY TWO LINE LEADS TO REVERSE ROTATION.
2. OPTIONAL THERMOSTATS ARE PROVIDED WHEN SPECIFIED.
3. ACTUAL NUMBER OF INTERNAL PARALLEL CIRCUITS MAY BE A MULTIPLE OF THOSE SHOWN ABOVE.
4. LEAD COLORS ARE OPTIONAL. LEADS MUST ALWAYS BE NUMBERED AS SHOWN.

REV. DESC: REVISE TO SHOW OPTIONAL COLORS			
REV. LTR: E	BY: JLP	REVISED: 01/19/99 10:15	TDR: 0171435
90000		FILE: AAA00005140	MDL: -
		MTL: -	

BALDOR ELECTRIC Co.

3PH, DV, 9 LEADS

CD0005