

# **BALDOR**® • *RELIANCE*

## **Product Information Packet**

# **EWCM3312T**

**10HP,3475RPM,3PH,60HZ,213TCZ,3728M,OPSB**

Part Detail							
Revision:	C	Status:	PRD/A	Change #:		Proprietary:	No
Type:	AC	Prod. Type:	3728M	Elec. Spec:	37WGS633	CD Diagram:	CD0005
Enclosure:	OPSB	Mfg Plant:		Mech. Spec:	37F978	Layout:	37LYF978
Frame:	213TCZ	Mounting:	F1	Poles:	02	Created Date:	05-28-2015
Base:	RG	Rotation:	R	Insulation:	F	Eff. Date:	11-06-2015
Leads:	9#14					Replaced By:	
Literature:		Elec. Diagram:					

Nameplate NP1259L										
CAT.NO.	EWCM3312T									
SPEC.	37F978S633G1									
HP	10									
VOLTS	230/460									
AMP	24/12									
RPM	3475									
FRAME	213TCZ				HZ	60			PH	3
SER.F.	1.15		CODE	G	DES	B		CL	F	
NEMA-NOM-EFF	89.5		PF	86						
RATING	40C AMB-CONT									
CC	010A				USABLE AT 208V	25.6				
DE	6309				ODE	6206				
ENCL	OPSB		SN							

Parts List		
Part Number	Description	Quantity
SA302310	SA 37F978S633G1	1.000 EA
RA289404	RA 37F978S633G1	1.000 EA
HA6361A01	LIFTING LUG FOR 37, 39 & 40 FRAME ZINC	2.000 EA
37CB3006	37 CB CASTING W/1.38 LEAD HOLE @ 6:00	1.000 EA
51XW2520A10	.25-20 X .62, TAPTITE II, HEX WSHR SLTD	2.000 EA
11XW1032G06	10-32 X .38, TAPTITE II, HEX WSHR SLTD U	1.000 EA
HW3001B01	BRASS CUP WASHER, FOR #8 SCREW	1.000 EA
37FE3200A15	FR ENDPLATE MACH	1.000 EA
HW4500A01	1641B(ALEMITE)400 UNIV, GREASE FITT	1.000 EA
HW4500A17	317400 ALEMITE GREASE RELIEF	1.000 EA
HA1104A01	RODENT SCREEN 37 FRAME 206 BRG FRONT END	1.000 EA
51XW1032A06	10-32 X .38, TAPTITE II, HEX WSHR SLTD S	4.000 EA
HW1000A10	#10 FLAT WASHER (SAE)	4.000 EA
HW5100A06	W2420-025 WVY WSHR (WB)	1.000 EA
37EP3401A08	PUEP 309 BRG NO BAFF, W/METAL SLINGER	1.000 EA
HW4500A01	1641B(ALEMITE)400 UNIV, GREASE FITT	1.000 EA
HA1222	RODENT SCREEN - 37 C-FACE MOTORS	4.000 EA
51XW1032A06	10-32 X .38, TAPTITE II, HEX WSHR SLTD S	4.000 EA
HW1000A10	#10 FLAT WASHER (SAE)	4.000 EA
10XN2520A36	1/4-20X 2 1/4 HEX HD X	4.000 EA
HW1001A25	LOCKWASHER 1/4, ZINC PLT .493 OD, .255 I	4.000 EA
XY3118A12	5/16-18 HEX NUT DIRECTIONAL SERRATION	4.000 EA
37CB4516	LIPPED LID FOR 37 FRAME NEC KOBX	1.000 EA
51XW0832A07	8-32 X .44, TAPTITE II, HEX WSHR SLTD SE	4.000 EA

<b>Parts List (continued)</b>		
<b>Part Number</b>	<b>Description</b>	<b>Quantity</b>
HA2009A02	SLINGER MODEL 37 PUMP MOTORS-2.75 DIA. A	1.000 EA
80XN1032A06	10-32 X 3/8 SET SC HEX SOCK	1.000 EA
HW2501D14	KEY, 3/16 SQ X 1.500	1.000 EA
HA7000A01	KEY RETAINER 7/8" DIA SHAFT	1.000 EA
85XU0407S04	4X1/4 U DRIVE PIN STAINLESS	2.000 EA
LB1115N	LABEL,LIFTING DEVICE (ON ROLLS)	1.000 EA
MJ1000A02	GREASE, POLYREX EM EXXON (USe 4824-15A)	0.050 LB
MG1000Y03	MUNSELL 2.53Y 6.70/ 4.60, GLOSS 20,	0.028 GA
HA3104A39	THRUBOLT-5/16-18 X 12.250	4.000 EA
37AD2001A01	BAFFLE PLATE, STAMPED	2.000 EA
LC0005E01	CONN.DIA./WARNING LABEL (LC0005/LB1119N)	1.000 EA
NP1259L	ALUM SUPER-E UL CSA-EEV CC NEMA PREMIUM	1.000 EA
G0PA1000	PKG GRP, PRINT PK1026A06	1.000 EA
MN416A01	TAG-INSTAL-MAINT no wire (1000/bx) 11/14	1.000 EA

**AC Induction Motor Performance Data**

Record # 53394 - Typical performance - not guaranteed values

<b>Winding:</b> 37WGS633-R009	<b>Type:</b> 3728M	<b>Enclosure:</b> OPSB
-------------------------------	--------------------	------------------------

Nameplate Data				460 V, 60 Hz: High Voltage Connection	
Rated Output (HP)	10			Full Load Torque	15 LB-FT
Volts	230/460			Start Configuration	direct on line
Full Load Amps	24/12			Breakdown Torque	51.1 LB-FT
R.P.M.	3475			Pull-up Torque	25.6 LB-FT
Hz	60	Phase	3	Locked-rotor Torque	30 LB-FT
NEMA Design Code	B	KVA Code	G	Starting Current	79 A
Service Factor (S.F.)	1.15			No-load Current	4.54 A
NEMA Nom. Eff.	89.5	Power Factor	86	Line-line Res. @ 25°C	0.98748 Ω
Rating - Duty	40C AMB-CONT			Temp. Rise @ Rated Load	29°C
S.F. Amps				Temp. Rise @ S.F. Load	35°C
				Locked-rotor Power Factor	35
				Rotor inertia	0.255 LB-FT <sup>2</sup>

Load Characteristics 460 V, 60 Hz, 10 HP

% of Rated Load	25	50	75	100	125	150	S.F.
Power Factor	52	74	82	86	88	88	87
Efficiency	84.2	89.7	90.6	90.2	89.3	87.9	89.7
Speed	3578.4	3552.7	3525.5	3493.1	3458.3	3422.6	3472
Line amperes	5.31	7.03	9.39	12	14.8	18	13.7

Performance Graph at 460V, 60Hz, 10.0HP Typical performance - Not guaranteed values

**BALDOR ELECTRIC COMPANY**

WINDING # 37WGS633

Typical performance - not guaranteed values.

10 HP 3 PH 60 HZ 3475 RPM 460 V 3728M

TORQUES(LB-FT): PO=51.1 PU=25.6 LR=30 LRA=79

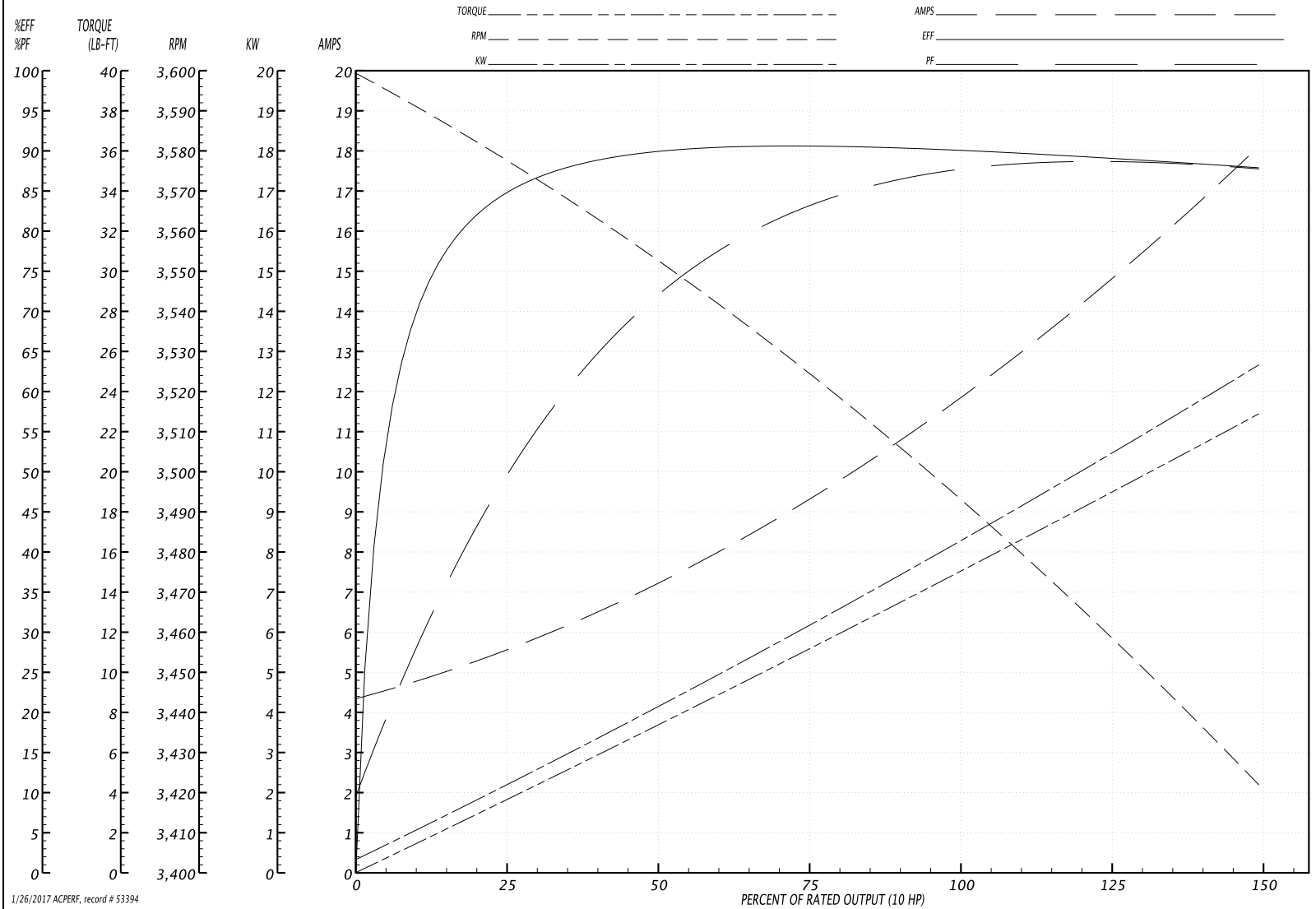

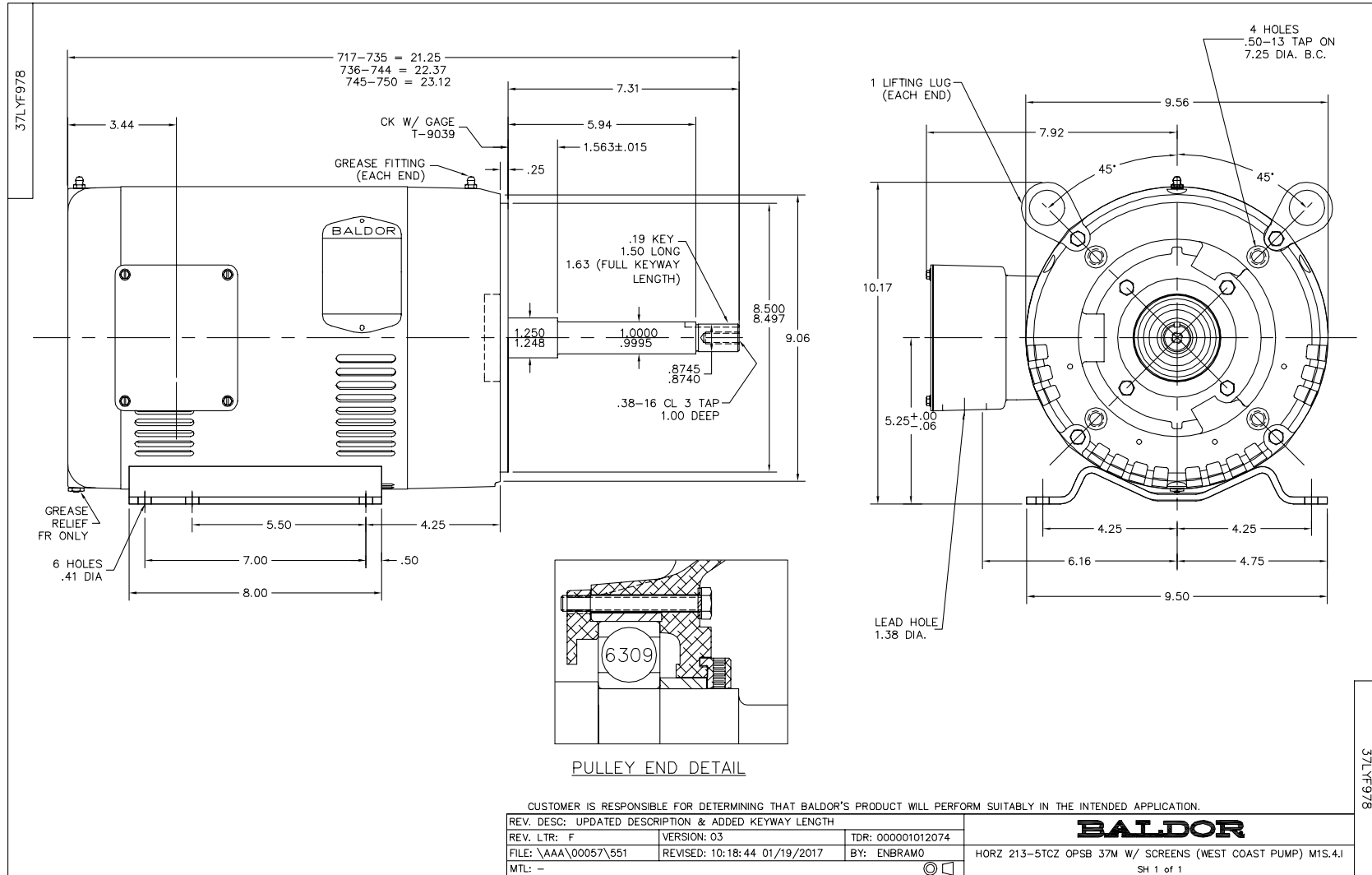

CD0005



LOW VOLTAGE  
(2Y)

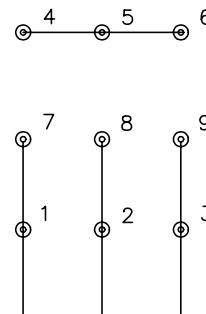

LINE

HIGH VOLTAGE  
(1Y)



LINE

NOTES:

1. INTERCHANGE ANY TWO LINE LEADS TO REVERSE ROTATION.
2. OPTIONAL THERMOSTATS ARE PROVIDED WHEN SPECIFIED.
3. ACTUAL NUMBER OF INTERNAL PARALLEL CIRCUITS MAY BE A MULTIPLE OF THOSE SHOWN ABOVE.
4. LEAD COLORS ARE OPTIONAL. LEADS MUST ALWAYS BE NUMBERED AS SHOWN.

REV. DESC: REVISE TO SHOW OPTIONAL COLORS			
REV. LTR: E	BY: JLP	REVISED: 01/19/99 10:15	TDR: 0171435
9000D		FILE: AAA00005140	MDL: -
		MTL: -	

**BALDOR ELECTRIC Co.**

3PH, DV, 9 LEADS

CD0005