

BALDOR® • **RELIANCE**

Product Information Packet

VM7010-5

.75HP, 1725RPM, 3PH, 60HZ, 56C, X3513M, XPFC

Part Detail							
Revision:	AA	Status:	PRD/A	Change #:		Proprietary:	No
Type:	AC	Prod. Type:	3513M	Elec. Spec:	35WG0464	CD Diagram:	CD0006
Enclosure:	XPFC	Mfg Plant:		Mech. Spec:	35E374	Layout:	35LYE374
Frame:	56C	Mounting:	F1	Poles:	04	Created Date:	
Base:	N	Rotation:	R	Insulation:	B	Eff. Date:	09-06-2016
Leads:	3#18					Replaced By:	
Literature:		Elec. Diagram:					

Nameplate NP1426XPSL

NO.		CC			
SER.					
SPEC.	35E374-0464G1				
CAT.NO.	VM7010-5				
HP	.75	T. CODE	T3C		
VOLTS	575				
AMPS	1.2				
RPM	1725				
HZ	60	PH	3	CL	B
SER.F.	1.00	DES	B	CODE	K
RATING	40C AMB-CONT				
FRAME	56C	NEMA-NOM-EFF		76	
USABLE AT 208V		PF	69		
BLANK					

Parts List		
Part Number	Description	Quantity
SA024069	SA 35E374-0464G1	1.000 EA
RA020119	RA 35E374-0464G1	1.000 EA
35CB3001A01SP	EXPL CONDUIT BOX, MACH, 1/2" PIPE TAP LE	1.000 EA
11XW1032G06	10-32 X .38, TAPTITE II, HEX WSHR SLTD U	1.000 EA
HW3001B01	BRASS CUP WASHER, FOR #8 SCREW	1.000 EA
35EP3700A01SP	FR ENDPLATE, XPFC	1.000 EA
HW5100A03SP	WAVY WASHER (W1543-017)	1.000 EA
35EP3702A01SP	PU EP-205 BRG-35X-56C-143-5TC	1.000 EA
51XN1032A20	10-32 X 1 1/4 HX WS SL SR	2.000 EA
XY3118A12	5/16-18 HEX NUT DIRECTIONAL SERRATION	4.000 EA
HA3013A01	1/2-20X5/8 SPL.HX BOLT	2.000 EA
HW3021C06	3/32 DI X .625 PIN (F/S)	2.000 EA
51XB1214A16	12-14X1.00 HXWSSLD SERTYB	1.000 EA
35FH4005A01SP	IEC FH NO GREASER W/PRIMED	1.000 EA
51XW1032A06	10-32 X .38, TAPTITE II, HEX WSHR SLTD S	3.000 EA
35CB3500A01SP	CONDUIT BOX LID, MACH	1.000 EA
51XN2520A16	SCREW, HEX WS SLT, ZN, 1/4-20 X 1.00	4.000 EA
HW2501D13	KEY, 3/16 SQ X 1.375	1.000 EA
HA7000A04	KEY RETAINER 0.625 DIA SHAFTS	1.000 EA
85XU0407S04	4X1/4 U DRIVE PIN STAINLESS	6.000 EA
NP0018F	ALUM UL XP CONDUIT BOX NAMEPLATE	1.000 EA
MJ1000A02	GREASE, POLYREX EM EXXON (USe 4824-15A)	0.050 LB
35FN3002A05	EXFN, PLASTIC, 6.376 OD, .638 ID	1.000 EA
51XB1214A16	12-14X1.00 HXWSSLD SERTYB	1.000 EA

Parts List (continued)		
Part Number	Description	Quantity
MG1025G29	WILKOFEST, 789.229, DARK CHARCOAL GRAY	0.017 GA
HA3104A06	THRUBOLT 5/16-18 X 8.50 OHIO ROD	4.000 EA
LB1119N	WARNING LABEL	1.000 EA
LC0006	CONNECTION LABEL	1.000 EA
NP1426XPSL	SS XP UL CSA CC CL-I GP-D CL-II GP-F&G	1.000 EA
36PA1000	PKG GRP, PRINT PK1016A06	1.000 EA
PK3082	STYROFOAM CRADLE	1.000 EA
MN416A01	TAG-INSTAL-MAINT no wire (1200/bx) 11/14	1.000 EA

AC Induction Motor Performance Data

Record # 20310 - Typical performance - not guaranteed values

Winding: 35WG0464-R002	Type: 3513M	Enclosure: XPFC
-------------------------------	--------------------	------------------------

Nameplate Data				575 V, 60 Hz: Single Voltage Motor	
Rated Output (HP)	.75			Full Load Torque	2.3 LB-FT
Volts	575			Start Configuration	direct on line
Full Load Amps	1.2			Breakdown Torque	9 LB-FT
R.P.M.	1725			Pull-up Torque	7 LB-FT
Hz	60	Phase	3	Locked-rotor Torque	7.5 LB-FT
NEMA Design Code	B	KVA Code	K	Starting Current	6.7 A
Service Factor (S.F.)	1			No-load Current	0.9 A
NEMA Nom. Eff.	76	Power Factor	69	Line-line Res. @ 25°C	43.3 Ω
Rating - Duty	40C AMB-CONT			Temp. Rise @ Rated Load	49°C

Load Characteristics 575 V, 60 Hz, 0.75 HP

% of Rated Load	25	50	75	100	125	150	S.F.
Power Factor	31	46	58	67	74	80	0
Efficiency	49	64	70.4	73.3	74.3	74.2	0
Speed	1781	1766	1750	1732	1712	1691	0
Line amperes	1	1	1.1	1.2	1.3	1.4	1.3

Performance Graph at 575V, 60Hz, 0.75HP Typical performance - Not guaranteed values

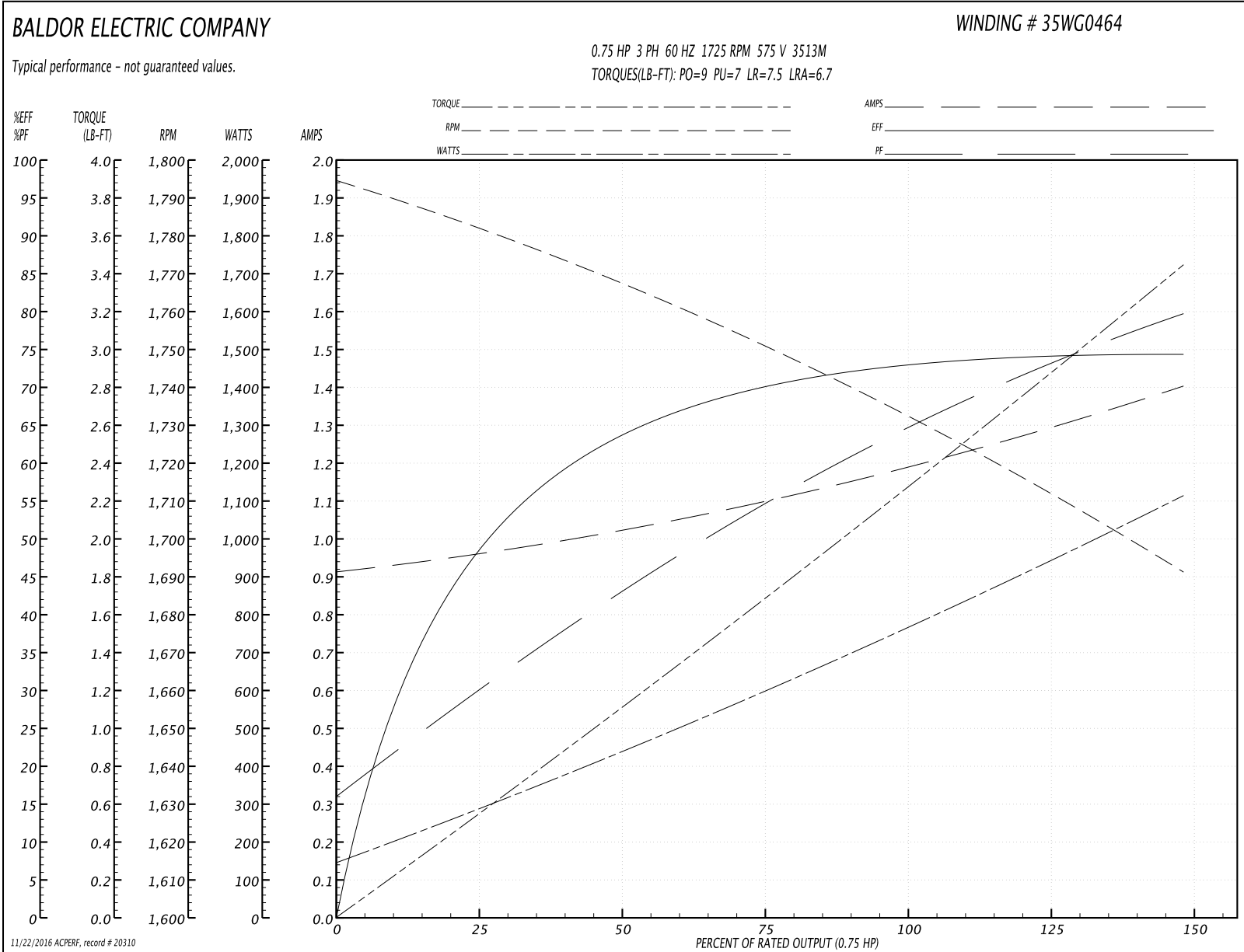

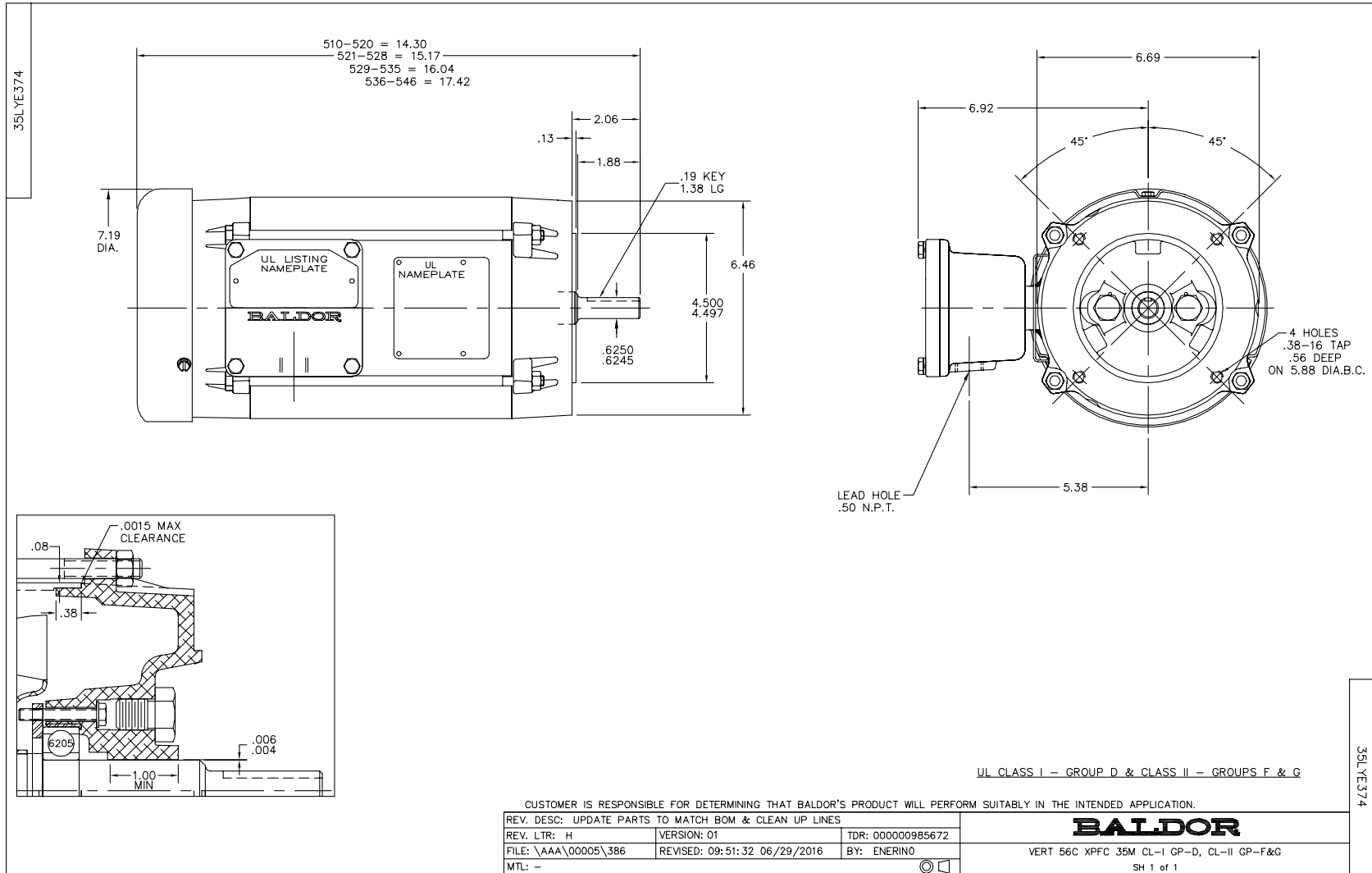

CD0006



NOTES:

1. THREE LEAD MOTOR MAY BE EITHER WYE CONNECTED OR DELTA CONNECTED.
2. INTERCHANGE ANY TWO LINE LEADS TO REVERSE ROTATION.
3. OPTIONAL THERMOSTATS ARE PROVIDED WHEN SPECIFIED.
4. ACTUAL NUMBER OF INTERNAL PARALLEL CIRCUITS MAY VARY.
5. LEAD COLORS ARE OPTIONAL. LEADS MUST BE NUMBERED AS SHOWN.

REV. DESC: REVISE TO SHOW OPTIONAL COLORS			
REV. LTR: D	BY: JLP	REVISED: 01/21/99 4:02	TDR: 0171435
9000D		FILE: AAA00005141	MDL: -
		MTL: -	

BALDOR ELECTRIC Co.

3PH, SV, 3 LEADS, WYE OR DELTA CONNECTED

CD0006