

BERKELEY®**P60R, P90R, PP60R and PP90R****Installation/Operation/Parts**

For further operating, installation, or maintenance assistance:

Call 888-782-7483

Important Safety Instructions

SAVE THESE INSTRUCTIONS - This manual contains important instructions that should be followed during installation, operation, and maintenance of the product. Save this manual for future reference.

▲ This is the safety alert symbol. When you see this symbol on your pump or in this manual, look for one of the following signal words and be alert to the potential for personal injury!

▲ DANGER indicates a hazard which, if not avoided, *will* result in death or serious injury.

▲ WARNING indicates a hazard which, if not avoided, *could* result in death or serious injury.

▲ CAUTION indicates a hazard which, if not avoided, *could* result in minor or moderate injury.

NOTICE addresses practices not related to personal injury. Keep safety labels in good condition. Replace missing or damaged safety labels.

▲ WARNING Fire and explosion hazard. Gasoline can explode. Store gasoline away from the engine. Add gasoline to the engine only when the engine is off. NEVER pump flammable or explosive chemicals such as gasoline with this pump. Pump only water with this pump.

▲ WARNING Burn hazard. Hot surface. The engine gets very hot during operation. Do not touch the engine surfaces. Keep children away. Allow the engine to cool before moving it indoors.

▲ WARNING Breathing Hazard. Carbon monoxide. Never run the engine in an enclosed space. Only use outdoors with plenty of ventilation.

California Proposition 65 Warning

▲ WARNING This product and related accessories contain chemicals known to the State of California to cause cancer, birth defects or other reproductive harm.

Technical Information

Priming Port: 1/2" BSP
 Max Working Pressure. 188 PSI (1300 kpa)
 Water Temperature Range 41° F - 104° F (5° C - 40° C)
 Maximum Ambient Temperature 104° F (40° C) as per engine manufacturer's data

Model Information

Single Stage Pump Models			
Pump Model	HP	Engine	Fuel
P60R	6	Robin EX17	1 gal (3.6 L) gas
P90R	9	Robin EX27	1.6 gal (6 L) gas
Twin Stage Pump Models			
PP60R	6	Robin EX17	1 gal (3.6 L) gas
PP90R	9	Robin EX27	1.6 gal (6 L) gas

Optional roll cage can be used with any model.

Installation

Preparation for operation

1. Read these instructions completely.
2. Inspect your pump for shipping damage. Report any damage to your Berkeley dealer.
3. Fill the engine crankcase with oil, as per the engine manufacturer's owner's manual.
4. Fill the fuel tank with unleaded gasoline (gasoline engine models), as per the engine owner's manual.
5. Make sure the suction piping is free of air leaks and is laid so that there can be no air locks.
6. Fit a strainer to the suction line

Pump Protection

Warranty of these pumps is void unless they are operated in accordance with this owner's manual and the enclosed engine manufacturer's owner's manual.

The pumps should be protected from the weather, floods, chemicals, dust, vermin, insects etc. If the pump has a fixed location; it should be housed in a weather proof, well-vented enclosure so that engine heat and exhaust can escape. When bolted down, flexible mounts should be used. Depending upon application they may not have to be bolted down.

Suction

▲ CAUTION Hazardous Suction. Can trap persons against suction inlet. Always use strainer on suction hose to prevent entrapment.

To maintain optimum performance from your pump, the suction pipe should be:

- Kept to the shortest length possible - place the pump as close to the water as possible.
- Use reinforced crush-resistant (non-collapsible) hose or pipe.
- Have all fittings be airtight
- Have flexible pipes rise gently from the water source to the suction/
- Use inlet port without excessive dips and sharp angles, to avoid air locks.
- Use pipes equal to or larger than the diameter of the suction/ Inlet port.
- Use suction strainers to prevent foreign matter entering the pump.
- Where practicable, use suction floats to aid in the performance of your pump, by keeping suction away from the debris on the bottom of the dam or river.
- Ensure that the suction is completely submersed.

Discharge

The length and diameter of the discharge hoses will affect the pressure and flow rate at which your pump operates. Long pipe runs and small diameter pipes lower pressure. Pressure ratings of all components must exceed the maximum pressure of the pump by an appropriate safety factor. We recommend the use of the Berkeley hose kit

- Suitable for either flexible or rigid piping.
- Models include 1-1/2" BSP side outlets.
- Models include 2" BSP front outlets.
- All have 2" priming inlets

Operation

Operation Guidelines

- Pumping water containing solids will reduce the life of the pump, and may affect warranty
- Pumping chemicals or agricultural products may affect the warranty. Please ask your Berkeley dealer about viton seals.
- The pump should be drained after use and flushed out with clean, fresh water. Flushing will extend the pump's life.
- Store your pump in a dry location.
- Service the engine as recommended in the engine manufacturer's owner's manual.
- Drain the fuel if the pump will not be used for more than two months. The engine will be difficult or unable to start if the fuel is stale.
- Always use original service parts as supplied and recommended by Berkeley and the engine manufacturer. Failure to do so may void warranty.

Operation Procedure

- a) Connect suction piping, and ensure that the suction is completely submerged.
- b) Remove the priming plug and fill the pump with water. Your pump is equipped with a suction flap valve and is capable of drawing air out of normal size suction pipes or hoses.
- c) Replace the priming plug - screw it down tightly to seal.
- d) Follow Engine Manufacturer's Instructions for starting the engine.

If only a small amount of water is pumped, and then flow stops, switch off the engine and check the suction pipe/hose assembly for possible air leaks. Repair leaks before starting priming procedure again.

Berkeley Pumper™ single stage pumps, when filled with water, will gradually draw air out of the suction line to a maximum prime depth of 6m.

The Berkeley Pumper Plus™ Twin models will prime to a maximum depth of 11.5 ft. (3.5m). If priming a long or larger diameter pipe, additional water may have to be added to the pump at 3-minute intervals.

- Switch off the engine each time.
- Do not remove any caps while the pump is operating.
- Ensure that your pump is filled with water before operating.

Engine-Driven Pump Disassembly: Single

Tools Required

1. 13mm socket
2. 14mm socket
3. 15mm socket
4. 19mm socket
5. 24mm socket
6. 14mm box wrench
7. Medium screwdriver
8. Hammer
9. Medium duty thread lock compound

⚠ CAUTION Hazardous voltage.
Remove spark plug wire from engine before working on pump.

Housing Removal

1. Remove the 4 suction flange bolts using a 13mm socket.



Figure 1: Suction Flange Removal

2. Remove suction flange.
 - Remove gasket and flap valve assembly.



Figure 2: Suction Flange Removal

3. Remove the front bolt on both sides of handle using a 19mm socket or box wrench.



Figure 3: Remove Front Bolts

4. Remove handle
 - Remove 4 bolts on the discharge housing using a 13mm socket.
 - Remove housing and gasket.



Figure 4: Remove discharge Assembly

5. Remove all casing bolts and nuts using 14mm socket and box wrench.



Figure 5: Casing Nut Removal

6. Remove casing from pump
 - Remove drain plug from casing.



Figure 6: Remove Casing

7. Gently pry the diffuser away from the seal plate using a screwdriver.



Figure 7: Remove Diffuser

8. Push the impeller wear ring out of the diffuser by pressing with your thumbs.



Figure 8: Remove Impeller Wear Ring

9. Remove the casing O-Ring from diffuser and seal plate.



Figure 9: Remove casing O-Ring

10. Gently tap the impeller counter-clockwise using a hammer and screwdriver and remove it from the engine shaft.

- Ensure that the flat blade of screwdriver is flat against impeller vane.



Figure 10: Remove Impeller

11. Remove rotating mechanical seal from back of impeller extension.



Figure 11: Remove Rotating Seal

12. Remove the 4 bolts holding seal plate to engine using a 13mm socket and then remove seal plate.



Figure 12: Seal plate Removal

13. Remove bolt seals from seal plate using a screwdriver.

- Turn the seal plate around and remove the stationary ceramic mechanical wear face.



Figure 13: Remove Bolt Seals

Pump is now completely disassembled.

Single Assembly

⚠ CAUTION Hazardous voltage.

Remove spark plug wire from engine before working on pump.

1. Push ceramic wear face into seal plate.
 - Push bolt seals into seal plate.
 - Do not use grease as a lubricant.



Figure 14: Install Seals

2. When installing seal plate onto engine ensure that slot in back of seal plate is facing downward.
 - This will allow water to drain out of pump and not into engine should seal failure occur.

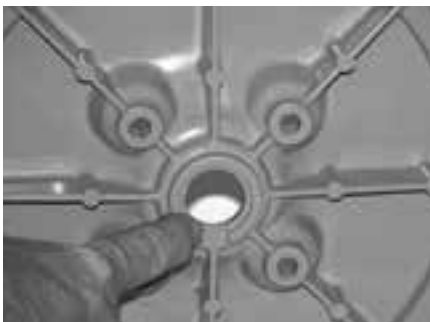

Figure 15: Orient Seal Plate

3. Insert one of the long casing bolts into right hand centre seal plate hole.
 - Push spacer onto the four seal plate bolts and apply medium duty thread lock compound to the thread.
 - Using 13mm socket tighten all seal plate bolts firmly to engine.



Figure 16: Fasten Seal Plate to Engine

4. Fit casing O-Ring to seal plate.



Figure 17: Install casing O-Ring

5. Fit rotating section of mechanical seal to extension on back of impeller.
 - Do not use lubricant on mechanical seal faces.



Figure 18: Install Rotating Seal

6. Turn the impeller clockwise onto the engine shaft until firm.



Figure 19: Install Impeller

7. Press impeller wear ring into the diffuser.



Figure 20: Install Impeller Wear Ring

8. Fit diffuser over the impeller and up to the seal plate.
 - Fit O-Ring to front of diffuser.



Figure 21: Install Diffuser

9. Fit casing to pump ensuring that O-Ring seats correctly into groove in casing.
 - This can be viewed through the front inlet on casing.



Figure 22: Fit Casing

10. Using 14mm socket and box wrench to tighten the casing evenly from corner to corner to ensure even compression of the casing O-Ring.
 - Angled metal foot fits onto the 2 bottom bolts and should cover the bottom of pump casing to prevent damage.



Figure 23: Fasten Casing

11. Fit flap valve and gasket to suction housing.
 - Ensure that the gasket fits properly with the raised lugs on housing fitting slots in gasket.



Figure 24: Install Flap Valve

12. Fit discharge gasket and discharge housing to casing.
 - Using 13mm socket tighten bolts in suction and discharge flange.
 - Bolts only need to be tightened firmly to prevent stripping the thread.



Figure 25: Fasten Suction and Discharge Flanges

13. Fit handle to long bolts on side of casing.
 - Using 19mm socket tighten handle sockets onto casing bolts.



Figure 26: Install Handle

14. Pump is now fully assembled ready for use.
 - Bench test the pump up to top pressure to ensure there are no seal, O-Ring or gasket leaks prior to returning to service.

This completes assembly of the single-stage pump.

Engine-Driven Pump Disassembly: Twin

Tools Required

1. 13mm socket
2. 14mm socket
3. 15mm socket
4. 19mm socket
5. 24mm socket
6. 14mm box wrench

1. **CAUTION Hazardous voltage.** Remove spark plug wire from engine before working on pump.
2. Using 19mm socket or box wrench, undo two bolts at bottom of handle and remove handle.



Figure 27: Remove The Handle

3. Using 13mm socket remove four suction flange bolts and remove flange.



Figure 28: Remove Suction Flange

4. Remove gasket and flap valve from suction flange.



Figure 29: Remove Flap Valve

5. Using 13mm socket remove four bolts from discharge housing and remove both housing and gasket.



Figure 30: Remove Discharge Housing

6. Using 14mm socket remove six casing bolts and nuts and remove casing from pump.



Figure 31: Remove Casing

7. Remove front O-Ring and front cover plate from pump.



Figure 32: Remove front O-Ring

8. After removing front cover plate press impeller wear ring out.



Figure 33: Remove Wear Ring

9. Using 15mm socket or box wrench undo impeller retaining bolt counter-clockwise and remove impeller from shaft extension.



Figure 34: Remove Impeller

10. After removing impeller from shaft extension remove front diffuser.



Figure 35: Remove Front Diffuser

11. Remove impeller spacer from engine shaft.



Figure 36: Remove Spacer

12. Remove 2nd diffuser from pump.



Figure 37: Remove Second Diffuser

13. Remove 2nd impeller from shaft extension.



Figure 38: Remove Second Impeller

14. Remove O-Ring and impeller wear ring from front of 2nd diffuser.



Figure 39: Remove Wear Ring

15. Using 24mm socket remove hexagonal shaft extension from engine shaft. If shaft extension is tight give ratchet handle a sharp hit with a hammer in an counter-clockwise direction to loosen.



Figure 40: Remove Shaft Extension

16. Remove rotating section of mechanical seal from engine shaft. Remove seal plate bolts using 13mm socket and remove the seal plate.



Figure 41: Remove Seal Plate Bolts

17. Remove the bolt seals and the stationary mechanical seal wear face from seal plate.



Figure 42: Remove Seal Plate and Seals

Pump is now fully disassembled.

Twin Assembly

CAUTION Hazardous voltage.

Remove spark plug wire from engine before working on pump.

1. Insert spacer and bolt seals onto seal plate bolts.



Figure 43: Insert Spacer

2. Insert stationary mechanical wear face and casing O-Ring onto seal plate. Do not use grease on either. Soap may be used if necessary.
 - Insert one long casing bolt into right hand side of seal plate prior to assembling to engine.



Figure 44: Prepare Seal Plate

3. When installing seal plate onto engine ensure that drain slot on the back is facing downward. Should the mechanical seal leak this will allow water to drain out of pump and not into the engine.



Figure 45: Seal Plate Drain Location

4. Apply medium duty thread lock compound to seal plate bolts and using 13mm socket, assemble pump seal plate to engine.



Figure 46: Install Seal plate Bolts

5. Carefully insert rotating mechanical seal onto shaft extension ensuring carbon face will seat against ceramic wear face in seal plate.
 - Using 24mm socket, screw hexagonal shaft extension onto engine shaft.



Figure 47: Install Seal and Extension

6. Slide 1st impeller onto shaft extension.



Figure 48: Install First Impeller

7. Place casing O-Ring around rear edge of seal plate.
 - Insert impeller wear ring into diffuser, turn diffuser around and push diffuser over impeller onto seal plate.



Figure 49: Install Diffuser

8. When positioning rear diffuser ensure locating lug is in the uppermost position.



Figure 50: Locate Diffuser

9. Insert O-Ring on front of rear diffuser.
 - Insert spacer onto shaft extension.

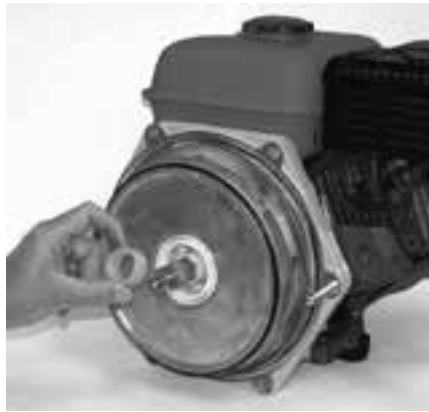

Figure 51: Insert Diffuser O-Ring

10. Ensure that locating lug on front diffuser is installed in the upright position.
 - Place front diffuser over shaft up to the rear diffuser.



Figure 52: Install Front Diffuser

11. Slide impeller onto shaft.
 - Using 15mm socket or box wrench tighten bolt and washer into shaft extension to hold front impeller.



Figure 52: Fasten Impeller

12. Insert impeller wear ring into front suction plate.



Figure 53: Install Wear Ring

13. Ensure that protruding lug on front diffuser locates into cavity as shown in front cover plate when putting in position over front impeller.



Figure 54: Position Front Diffuser

14. Push casing over the whole assembly ensuring that locating lugs and cover plate O-Ring all seat properly. If assembly is not correct the casing will not push up neatly to the seal plate.

- Using 14mm socket tighten six casing bolts and nuts in a diagonal pattern to ensure even compression of casing O-Ring.



Figure 55: Install Casing

15. The metal foot fits under the pump casing onto two bottom casing bolts.

- The angle should face forwards under pump casing to prevent powder coating being scratched causing possible corrosion.



Figure 56: Install Support Foot

16. Using 13mm socket install discharge gasket and four way flange to the top of pump casing.



Figure 57: Install Discharge Flange

17. Place gasket and flap valve assembly onto suction flange as shown.

- Ensure that lugs on flange locate correctly through holes in gasket.



Figure 58: Install Flap Valve

18. Using 13mm socket firmly tighten suction housing into place.

- Do not over-tighten as threads in casing may strip.



Figure 59: Tighten Suction Housing

19. Place handle over two long casing bolts.

- Using 19mm socket or box wrench tighten the two handle bolts to casing.
- Pump is now fully assembled.
- Install on test bench and run up to top pressure to ensure no leaks from casing O-Ring, gaskets or mechanical seal.



Figure 60: Install Handle

This completes assembly of the pump.

Single Stage Models

P60R

P90R

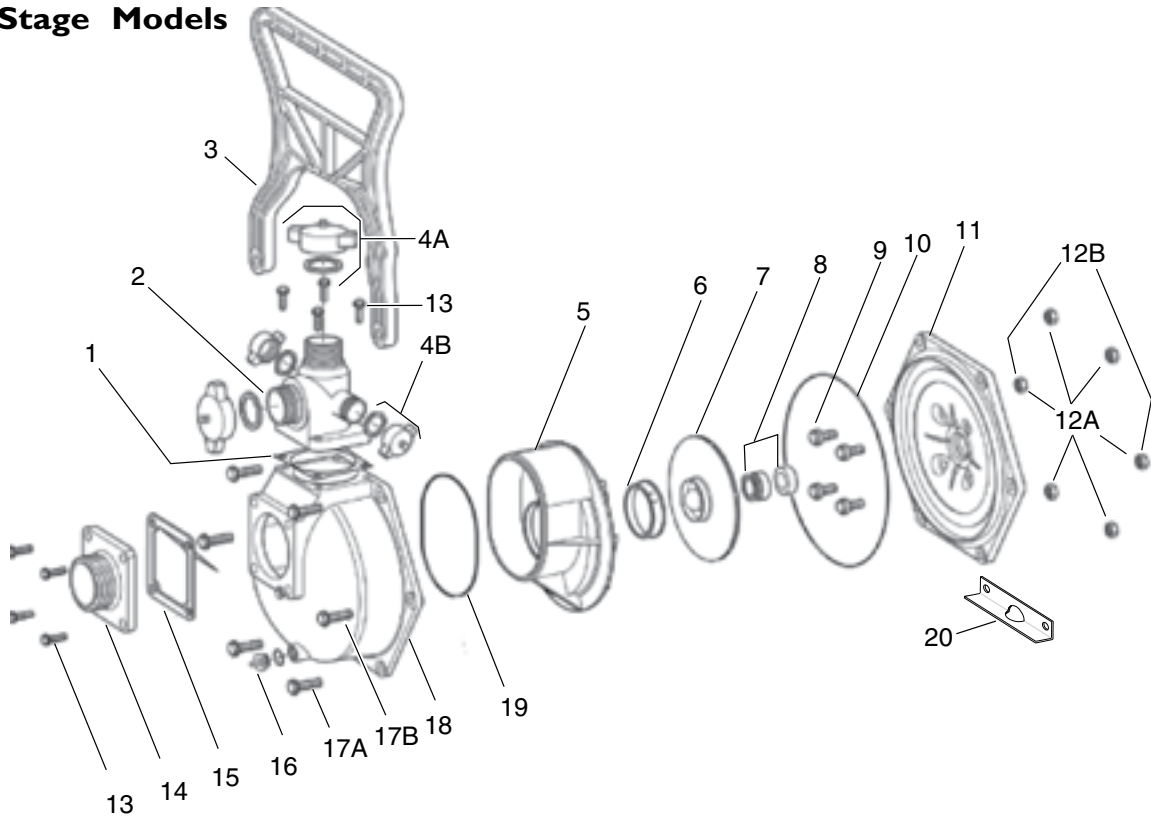

Ref.	Part Description	Qty.	P60R		P90R	
			B82932	B82933	B82934	B82935
1	Discharge Gasket	1	510960		510960	
2	Discharge Flange - 2" BSP	1	410943S		410943S	
3	Handle*	1	305590		-	
4A	Cap & Washer 2" BSP	2	505331		505331	
4B	Cap & Washer 1" BSP	2	502340		502340	
5	Diffuser	1	411420		411420	
6	Wear Ring	1	510970		510980	
7	Impeller	1	512140		511210	
8	Seal - Mechanical	1	700270		M15626	
•	Seal Plate Bolt Spacer	4	609070		-	
9	Bolt	4	700644		700644	
•	Washer	4	601870		601870	
10	Casing O-Ring	1	702216		702216	
11	Seal Plate (Yoke)	1	305493S		305503S	
12A	3/8" Casing Nuts (Set/12)***	6	700197		700197	
12B	3/8" Casing Nut w/Bushing for Handle*	2	609010		-	
13	Screw (Set/8 M8)	1	707302		707302	
14	Suction Flange - 2" BSP	1	410863S		410863S	
15	Flap Valve Assembly Gasket	1	410880		410880	
16	1/4" Drain Plug (Including O-Ring)	1	503362		503362	
17A	Casing Bolts - 3/8" x 2"***	6	702639		702639	
17B	Casing and Handle Bolts - 3/8" x 3"*	2	702806		-	
18	Casing	1	305483S		305483S	
19	Diffuser O-Ring	1	705901		705901	
20	Bracket	1	608960		-	
•	Cap Strap (Triple)	1	505382		505382	
•	Roll Cage Assembly**	1	B72301		B72301	

• Not illustrated.

* B82932 Only

** B82933, B82935 Only

*** B82932 uses 4.

Multi-Stage Models

PP60R

PP90R

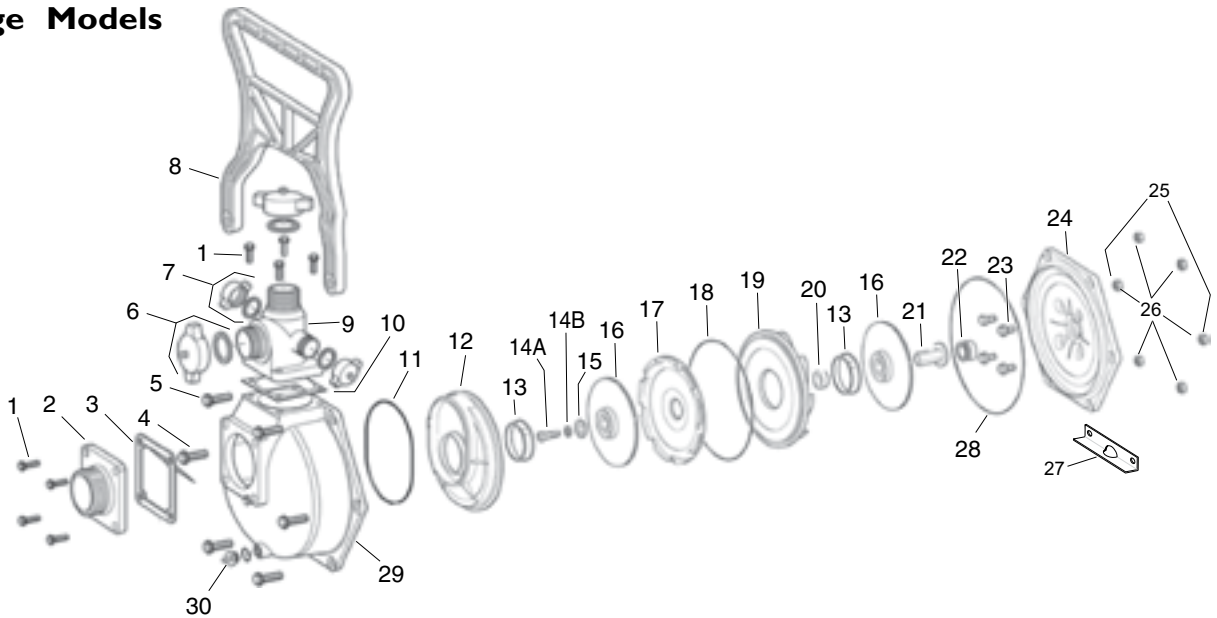

Ref.	Part Description	Qty.	PP60R B82937 B82936	PP90R B83149 B83148
1	Screw (Set/8) M8	8	707302	707302
2	Suction Flange - 2" BSP	1	410863S	410863S
3	Flap Valve Assembly Gasket	1	410880	410880
4	3/8" x 2" Casing Bolts***	6	702639	702639
5	3/8" x 3" Casing and Handle Bolts*	2	702806	-
6	Cap and Washer - 2" BSP	2	505331	505331
7	Cap and Washer - 1" BSP	2	502340	502340
8	Handle*	1	305590	-
9	Discharge Flange - 2" BSP	1	410943S	410943S
10	Discharge Gasket	1	510960	510960
11	Suction Cover O-Ring	1	705901	705901
12	Suction Cover	1	305555	305555
13	Wear Ring	2	510970	510980
14A	Impeller Screw	1	702592	702592
14B	Spring Washer	1	705886	705886
15	Impeller Washer	1	609040	609040
16	Impeller	2	512120	512130
17	Interstage Diffuser	1	305538	305538
18	Interstage Diffuser O-Ring	1	702261	702261
19	2nd Stage Diffuser	1	305515	305515
20	Spacer Sleeve	1	608770	608780
21	Stub Shaft	1	608930	608950
22	Mechanical Seal	1	700270	M15626
•	Seal Plate Bolt Spacer	4	609070	-
23	Bolt	4	601870	601870
•	Washer	4	700644	700658
24	Seal Plate	1	305493S	305503S
25	3/8" Casing Nut w/Bush for Handle*	2	609010	-
26	Casing Nuts (Set/12)***	6	700197	700197
27	Bracket	1	608960	-
28	Casing O-Ring	1	702216	702216
29	Casing	1	305483S	305483S
30	1/4" Drain Plug (Includes O-Ring)	1	503362	503362
•	Cap Strap (Triple)	1	505382	503382
•	Anti-Vibration Feet (Set/2)	1	801356K	801356K
•	Roll Cage Assembly**	1	B72301	B72301

• Not illustrated.
 * B82936 Only
 ** B82937, B83149 Only
 *** B82936 uses 4

	Cause	Corrective Action
1. Engine	A. Speed too low.	Refer to engine manual.
	B. Rotating and/or reciprocating parts drag.	Refer to engine manual.
	C. Speed too high.	Maximum engine speed not to exceed engine manufacturer's recommendation.
	D. Loose or broken parts.	Refer to engine manual.
2. Pump	E. Not primed.	Reprime, inspect suction system for air leaks, and or clack assembly.
	F. Pump takes too long to prime.	Check for air leaks or defective check valve.
	G. Flow through pump completely or partially blocked.	Locate and remove obstruction. Attach strainer.
	H. Internal leakage.	Check clearances between face of vanes and case. Should not exceed 1/32".
	I. Rotating parts drag.	Inspect. Repair.
	J. Loose or broken parts.	Inspect. Repair.
3. System	K. Pressure required by system at design flow rate exceeds pressure rating of pump.	Compare pump pressure and flow rate against pump performance chart. Reduce system pressure requirement. Increase pressure capability of pump.
	L. Obstruction in suction piping.	Locate and remove obstruction. Attach strainer.
	M. Suction lift too high.	Check with gauge or measure vertical distance between water surface and center line of pump, allowing for friction loss in suction pipe. Reduce rate of flow to obtain desired lift. Refer to pump performance chart.
	N. Discharge head too low.	Decrease rate of flow.
	O. Suction inlet not immersed deep enough.	Make sure suction inlet is fully submersed.
	P. Leaky suction line or connection admitting air.	Repair or replace suction line. Tighten connections.

Limited Warranty

BERKELEY warrants to the original consumer purchaser (“Purchaser” or “You”) of the products listed below, that they will be free from defects in material and workmanship for the Warranty Period shown below.

Product	Warranty Period
Water Systems:	
Water Systems Products — jet pumps, small centrifugal pumps, submersible pumps and related accessories	<i>whichever occurs first:</i> 12 months from date of original installation, or 18 months from date of manufacture
Pro-Source™ Composite Tanks	5 years from date of original installation
Pro-Source™ Steel Pressure Tanks	5 years from date of original installation
Pro-Source™ Epoxy-Lined Tanks	3 years from date of original installation
Sump/Sewage/Effluent Products	12 months from date of original installation, or 18 months from date of manufacture
Agricultural/Commercial:	
Centrifugals – close-coupled motor drive, frame mount, SAE mount, engine drive, VMS, SSCX, SSHM, solids handling, submersible solids handling	12 months from date of original installation, or 24 months from date of manufacture
Submersible Turbines, 6” diameter and larger	12 months from date of original installation, or 24 months from date of manufacture

Our limited warranty will not apply to any product that, in our sole judgement, has been subject to negligence, misapplication, improper installation, or improper maintenance. Without limiting the foregoing, operating a three phase motor with single phase power through a phase converter will void the warranty. Note also that three phase motors must be protected by three-leg, ambient compensated, extra-quick trip overload relays of the recommended size or the warranty is void.

Your only remedy, and BERKELEY’s only duty, is that BERKELEY repair or replace defective products (at BERKELEY’s choice). You must pay all labor and shipping charges associated with this warranty and must request warranty service through the installing dealer as soon as a problem is discovered. No request for service will be accepted if received after the Warranty Period has expired. This warranty is not transferable.

BERKELEY SHALL NOT BE LIABLE FOR ANY CONSEQUENTIAL, INCIDENTAL, OR CONTINGENT DAMAGES WHATSOEVER. THE FOREGOING LIMITED WARRANTIES ARE EXCLUSIVE AND IN LIEU OF ALL OTHER EXPRESS AND IMPLIED WARRANTIES, INCLUDING BUT NOT LIMITED TO IMPLIED WARRANTIES OF MERCHANTABILITY AND FITNESS FOR A PARTICULAR PURPOSE. THE FOREGOING LIMITED WARRANTIES SHALL NOT EXTEND BEYOND THE DURATION PROVIDED HEREIN.

Some states do not allow the exclusion or limitation of incidental or consequential damages or limitations on the duration of an implied warranty, so the above limitations or exclusions may not apply to You. This warranty gives You specific legal rights and You may also have other rights which vary from state to state.

This Limited Warranty is effective June 1, 2011 and replaces all undated warranties and warranties dated before June 1, 2011.

In the U.S.: BERKELEY, 293 Wright St., Delavan, WI 53115
In Canada: 269 Trillium Dr., Kitchener, Ontario N2G 4W5

This page intentionally left blank

This page intentionally left blank

