

SELF-PRIMING CENTRIFUGAL "T" PUMP

EXPLODED VIEW PARTS DIAGRAM

PARTS LIST
PP-9920K
JAN 2021

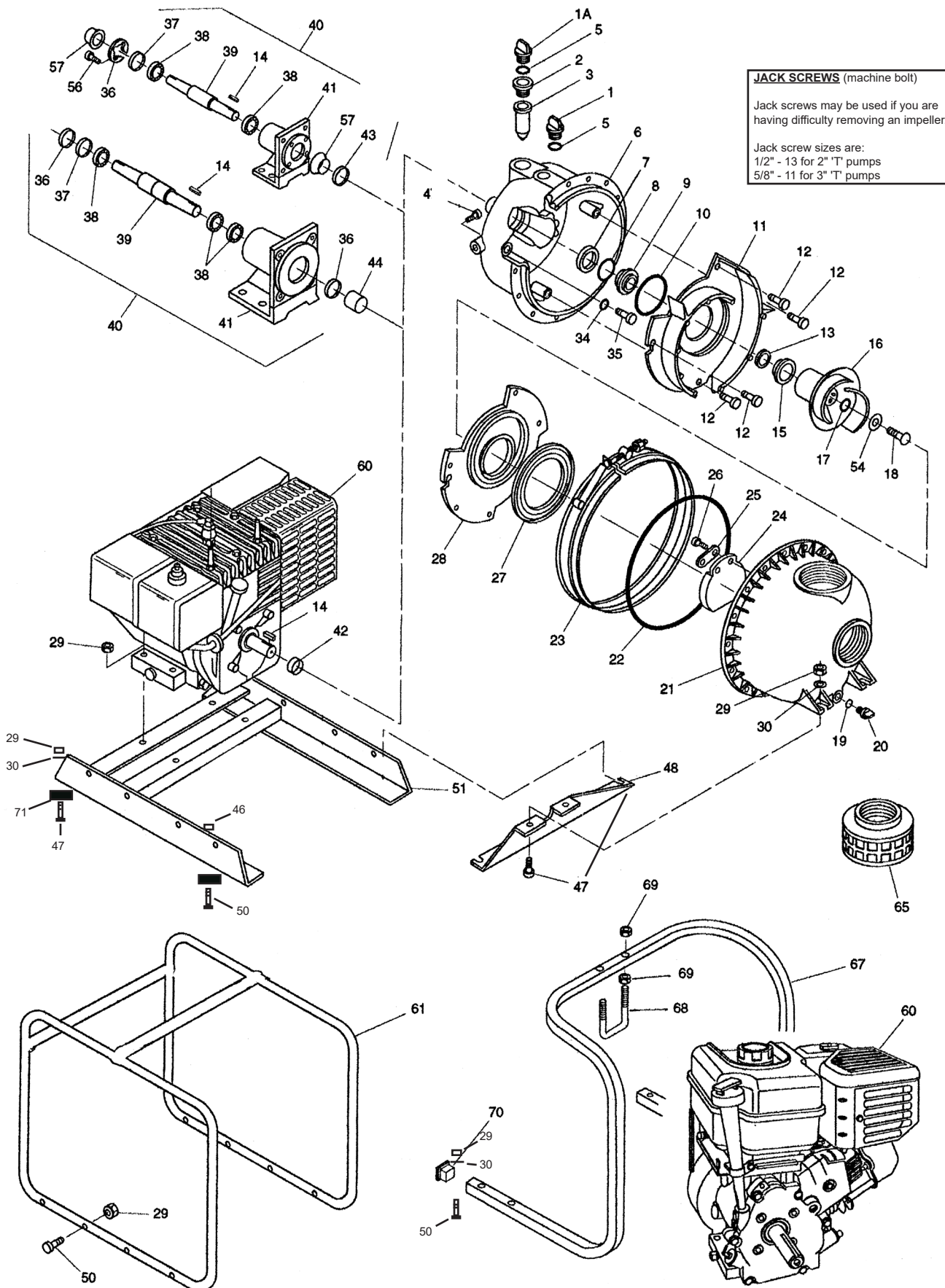

41 Industrial Circle
Lancaster PA 17601
email: sales@pacerpumps.com
www.pacerpumps.com

Phone: 717-925-8240
Toll Free: 800-233-3861
FAX: 717-925-8242



"T" PUMP PARTS LIST

*All parts may be used for either 2" or 3" pumps unless specifically designated otherwise.

PUMP				PUMP					
ITEM #	SIZE*	PART #	PART DESCRIPTION	QTY./PUMP	ITEM #	SIZE*	PART #	PART DESCRIPTION	QTY./PUMP
1		58-0722 30B	PLUG, Filler, Polyester	1	28	2"	58-46225 91	WEARPLATE, Rubber coated with Steel core	1
1A		58-0722 30B	PLUG Filler, Oil Lube, Polyester	1	3"	58-46205 91	WEARPLATE, Rubber coated with Steel core	1	
2		58-46294 30	RETAINER Lube Tube	1	29		58-0745	KEPNUT, 5/16"-18, plated steel as req'd	
3		58-46215 71	TUBE, Lubrication, Buna-n	1	30		58-0730	WASHER, flat, 5/16", plated steel, Engine drive only	as required
5		58-0765 71	O-RING, Filler Plug, Buna-N	2	31		58-46274	HOLDER, Spanner Wrench, Steel	1
6	2"	58-46218 31B	BRACKET Assy, Includes Items 1, 1A, 2, 3, 5, 6, 7, 8, 9	1	34	2"	58-0717 71	O-RING, Bracket screw, Buna-N	4
	2"	58-46218 30B	BRACKET ONLY	1	3"	58-46303 71	O-RING, Bracket screw, Buna-N	4	
	3"	58-46208 31B	BRACKET Assy, Includes Items 1, 1A, 2, 3, 5, 6, 7, 8, 9	1	35	2"	58-0715 10	SCREW, Bracket, 5/16"-24 x 1-1/4" S.S.	4
	3"	58-46208 30B	BRACKET ONLY	1	3"	58-46308 10	SCREW, Bracket, 3/8"-16 x 1-3/4" S.S.	4	
7	2"	58-46314 11	SEAL, Oil Lip	1	36	2"	58-1953 10	END PLATE, Stainless Steel	1
	3"	58-46313 11	SEAL, Oil Lip	1	3"	58-46354	RING, Snap, Retaining, Steel	2	
8	2"	58-0976 71	O-RING, Shaft Seal, Buna-N	1	37	2"	58-1956 10	SHIM, Stainless Steel	as required
	3"	58-46307 71	O-RING, Shaft Seal, Buna-N	1	3"	58-46353 10	SHIM, Stainless Steel	as required	
8, 9 & 15	2"	58-46250 11	SEAL, Shaft, Stainless Steel, Siliconized Graphite, Buna-N	1	38	2"	58-1954 90	BEARING	2
	3"	58-46251 11	SEAL, Shaft, Stainless Steel, Silicon Carbide, Buna-N	1	3"	58-46372 90	BEARING, for 58-46350 03 Ped. Assy.	3	
10	2"	58-1203 71	O-RING, Volute, Buna-N	1	39	2"	58-1952 10	SHAFT, 3/4" diameter, Stainless Steel	1
	3"	58-46292 71	O-RING, Volute, Buna-N	1	3"	58-46371 10	SHAFT, 1" x 1-1/8" diameter, Stainless Steel for 58-46350 03 ped assy.	1	
11	2"	58-46224 80	VOLUTE, Urethane coated with Steel core	1	40	2"	58-1950 03	PEDESTAL ASSY, includes items 36, 37, 38, 39, 41, 43, 56 & 57 (3/4" shaft)	1
	3"	58-46204 80	VOLUTE, Urethane coated with Steel core	1	3"	58-46350 03	PEDESTAL ASSY, includes items 36, 37, 38, 39, 41 & 44 (1" shaft)	1	
12	2"	58-46269 10	SCREW, Button Head 1/4"-20 x 1" Stainless Steel	2	41	2"	58-1951 90	HOUSING, bearing pedestal, for 3/4" shaft	1
	3"	58-46269 10	SCREW, Button Head 1/4"-20 x 1" Stainless Steel	4	3"	58-46373 90	HOUSING, bearing pedestal for 58-46350 03 Pedestal Assembly	1	
13	2"	58-0778 11	SHIM, Impeller, .006" S.S.	as required	42	2"	58-0884 71	SLINGER, for 3/4" shaft	1
	2"	58-0778 12	SHIM, Impeller, .015" S.S.	as required	3"	58-46266 71	SLINGER, for 1" shaft	1	
	2"	58-0778 13	SHIM, Impeller, .030" S.S.	as required	43	2"	58-46219 10	SLEEVE, for 3/4" shaft, Stainless Steel	1
	3"	58-46338 10	SHIM, Impeller .015" S.S.	as required	44	3"	58-46359 10	SLEEVE, for 1" shaft, s.s., pedestal only	1
14	2"	58-46339	KEY, 3/16" x 11/16" long, steel	1	45	2"	58-46279	BOLT, eye, plated steel	2
	3"	58-46278	KEY, 1/4" x 1" long, steel	1	3"	58-2167	SCREW, 5/16-18 x 1 1/2", plated steel	2	
16	2"	58-46229 80	IMPELLER, Urethane coated with Steel core	1	46		58-46280	NUT, flange, 5/16-18, plated steel	2
	2"	58-46229 81	IMPELLER Assy, as above but with siliconized graphite seal half installed	1	47		58-0729	SCREW, 5/16"-18 x 1", plated steel Engine drive only	as required
	2"	58-46229 90	IMPELLER, Molded, Polymar 656	1	48	2"	58-46306	SUPPORT, Front housing, 17" long, Painted steel	1
	2"	58-46229 91	IMPELLER Assy, Molded Polymar 656 with siliconized graphite seal half installed	1	3"	58-46365	SUPPORT, Front housing, 19-15/16" Long, Painted steel	1	
	3"	58-46214 80	IMPELLER, Urethane coated with Steel core	1	50		58-2167	SCREW, 5/16"-18 x 1-1/2", plated steel	as required
	3"	58-46214 81	IMPELLER, Assy, as above but with silicon carbide seal half installed	1	51	2"	58-46310	CHASSIS weldment, painted steel	1
	3"	58-46214 90	IMPELLER, Molded, Polymar 656	1	3"	58-46379	CHASSIS weldment, painted steel	1	
	3"	58-46214 91	IMPELLER, Assy, Molded Polymar 656 with silicon carbide seal half installed	1	54	2"	58-46341	WASHER, Impeller screw, rubber coated	1
17	2"	58-46291 71	O-RING, Impeller Screw, Buna-N All 2" & 3" Polymar 656 impellers	1	56	2"	58-2525 10	SCREW, hex, 1/4"-20 x 3/4", Stainless	4
	3"	58-46290 71	O-RING, Impeller Screw, Buna-N Urethane coated 3" impellers only	1	57	2"	58-1955 71	LIP SEAL, Buna-N	2
18	2"	58-0715 10	SCREW, Impeller, 5/16"-24 x 1-1/4" Stainless Steel	1	60	2"		Consult factory for replacement engine information	1
	3"	58-46309 10	SCREW, Impeller, 7/16"-20 x 1-1/4" Stainless Steel	1	3"			Consult factory for replacement engine information	1
19		58-1009 71	O-RING, Drain plug, Buna-N	1	61	3"	58-46254	ROLL CAGE, for 3" 'T' pump	1
20		58-0723 30	PLUG, Drain, Polyester	1	65	2"	58-46286 RH.	STRAINER, Suction, Plated Steel	1
21	2"	58-46252 31B	BODY Assy, Includes items 19, 20, 24, 25, 26, 27 and the body	1	3"	58-46287 RH.	STRAINER, Suction, Plated Steel	1	
	2"	58-46252 30B	BODY ONLY	1	67	2"	58-2035	CARRYING HANDLE, for 2" 'T' pump	1
	3"	58-46207 31B	BODY Assy, Includes items 19, 20, 24, 25, 26, 27 and the body	1	68	2"	58-2036	U BOLT, 3/8-16, Plated Steel	1
	3"	58-46207 30B	BODY ONLY	1	69	2"	58-2037	HEX NUT, 3/8-16, Plated Steel	4
22		58-46304 71	O-RING, Body, Buna-N	1	70	2"	58-0726 90	FINISHING CAP, Plastic	2
23		58-46305 10	CLAMP, V-Band, Stainless Steel	1	71	2"	58-0727 90	RUBBER FEET	4
24		58-46217 71	VALVE, Check, Buna-N	1	3"	58-46378 90	RUBBER FEET	4	
25		58-46344 30	RETAINER, Check valve, Polyester	1					
26		58-1348 10	SCREW, check valve retainer, #10-14 x 3/4" self-tapping, Stainless Steel	2					
27		58-46206 71	GASKET, Suction, Buna-N	1					



Division of ASM Industries, Inc.

41 Industrial Circle Phone: 717-925-8240
 Lancaster PA 17601 Toll Free: 800-233-3861
 email: sales@pacerpumps.com FAX: 717-925-8242
 www.pacerpumps.com

