



**STA-RITE®**

OWNER'S MANUAL  
**60 CYCLE SELF-PRIMING  
CENTRIFUGAL PUMPS  
"D" SERIES**

**INSTALLATION AND OPERATING INSTRUCTIONS  
REPAIR PARTS LIST**

		<b>MODELS</b>			
	<b>1 HP</b>	<b>1-1/2 HP</b>	<b>2 HP</b>	<b>2-1/2 HP</b>	
<b>MEDIUM HEAD</b>			DMG-41L DMG3-41	DMMG-42L DMMG3-42 DMM2G-42	
<b>HIGH HEAD</b>	DHE-50L DHE3-50 DH2E3-50	DHF-51L DHF3-51	DHG-52L DHG3-52	DHHG-53L DHHG3-53	

**Limited Warranty**

STA-RITE warrants to the original consumer purchaser ("Purchaser" or "You") of the products listed below, that they will be free from defects in material and workmanship for the Warranty Period shown below.

<b>Product</b>	<b>Warranty Period</b>
Water Systems Products — jet pumps, small centrifugal pumps, submersible pumps and related accessories	<i>whichever occurs first:</i> 12 months from date of original installation, or 18 months from date of manufacture
Pro-Source® Composite Tanks	5 years from date of original installation
Pro-Source® Steel Pressure Tanks	5 years from date of original installation
Pro-Source® Epoxy-Lined Tanks	3 years from date of original installation
Sump/Sewage/Effluent Products	12 months from date of original installation, or 18 months from date of manufacture

Our warranty will not apply to any product that, in our sole judgement, has been subject to negligence, misapplication, improper installation, or improper maintenance. Without limiting the foregoing, operating a three phase motor with single phase power through a phase converter will void the warranty. Note also that three phase motors must be protected by three-leg, ambient compensated, extra-quick trip overload relays of the recommended size or the warranty is void.

Your only remedy, and STA-RITE's only duty, is that STA-RITE repair or replace defective products (at STA-RITE's choice). You must pay all labor and shipping charges associated with this warranty and must request warranty service through the installing dealer as soon as a problem is discovered. No request for service will be accepted if received after the Warranty Period has expired. This warranty is not transferable.

STA-RITE SHALL NOT BE LIABLE FOR ANY CONSEQUENTIAL, INCIDENTAL, OR CONTINGENT DAMAGES WHATSOEVER. THE FOREGOING WARRANTIES ARE EXCLUSIVE AND IN LIEU OF ALL OTHER EXPRESS AND IMPLIED WARRANTIES, INCLUDING BUT NOT LIMITED TO THE IMPLIED WARRANTIES OF MERCHANTABILITY AND FITNESS FOR A PARTICULAR PURPOSE. THE FOREGOING WARRANTIES SHALL NOT EXTEND BEYOND THE DURATION EXPRESSLY PROVIDED HEREIN.

Some states do not allow the exclusion or limitation of incidental or consequential damages or limitations on the duration of an implied warranty, so the above limitations or exclusions may not apply to You. This warranty gives You specific legal rights and You may also have other rights which vary from state to state.

This Limited Warranty is effective June 1, 2011 and replaces all undated warranties and warranties dated before June 1, 2011.

**STA-RITE INDUSTRIES**  
**293 Wright Street • Delavan, WI U.S.A. 53115**  
**Phone: 1-888-782-7483 • Fax: 1-800-426-9446 • Web Site: sta-rite.com**

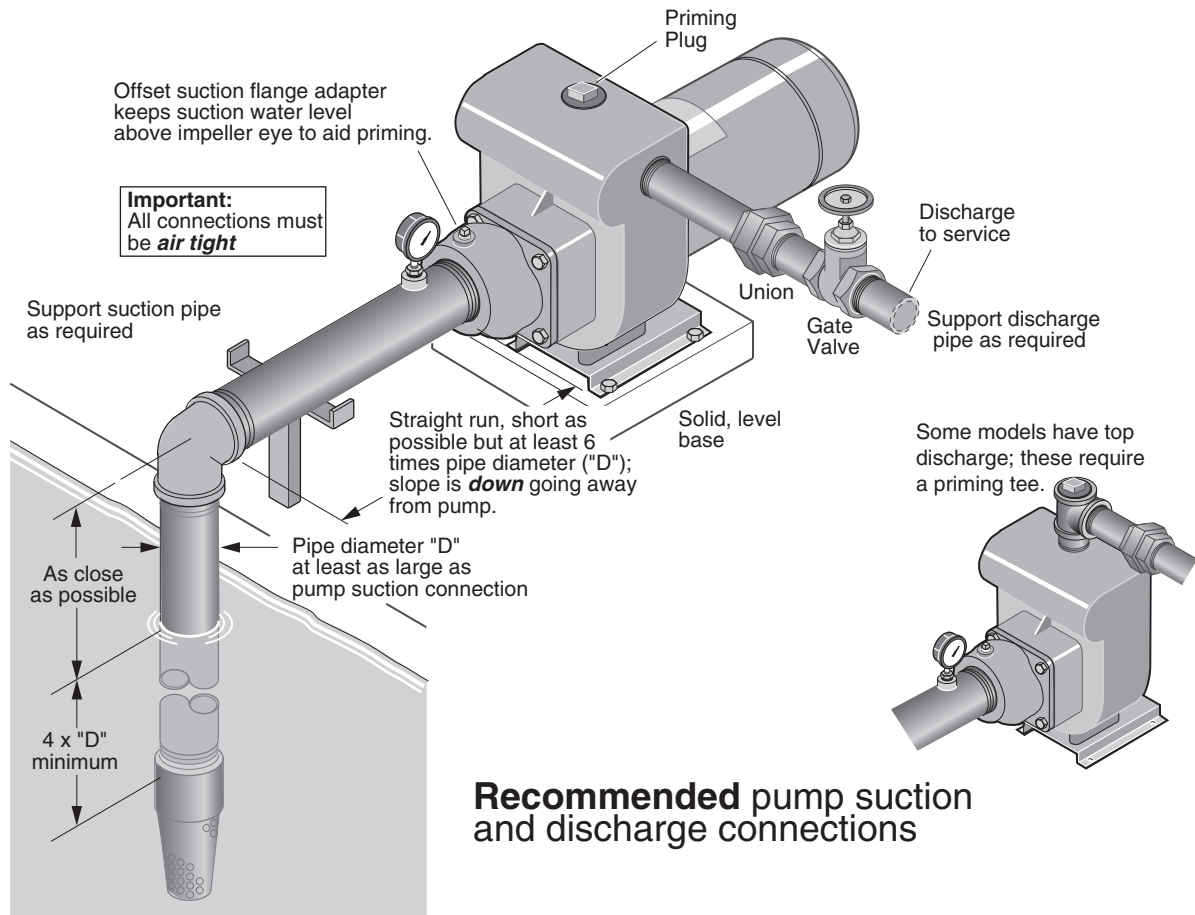

Figure 1

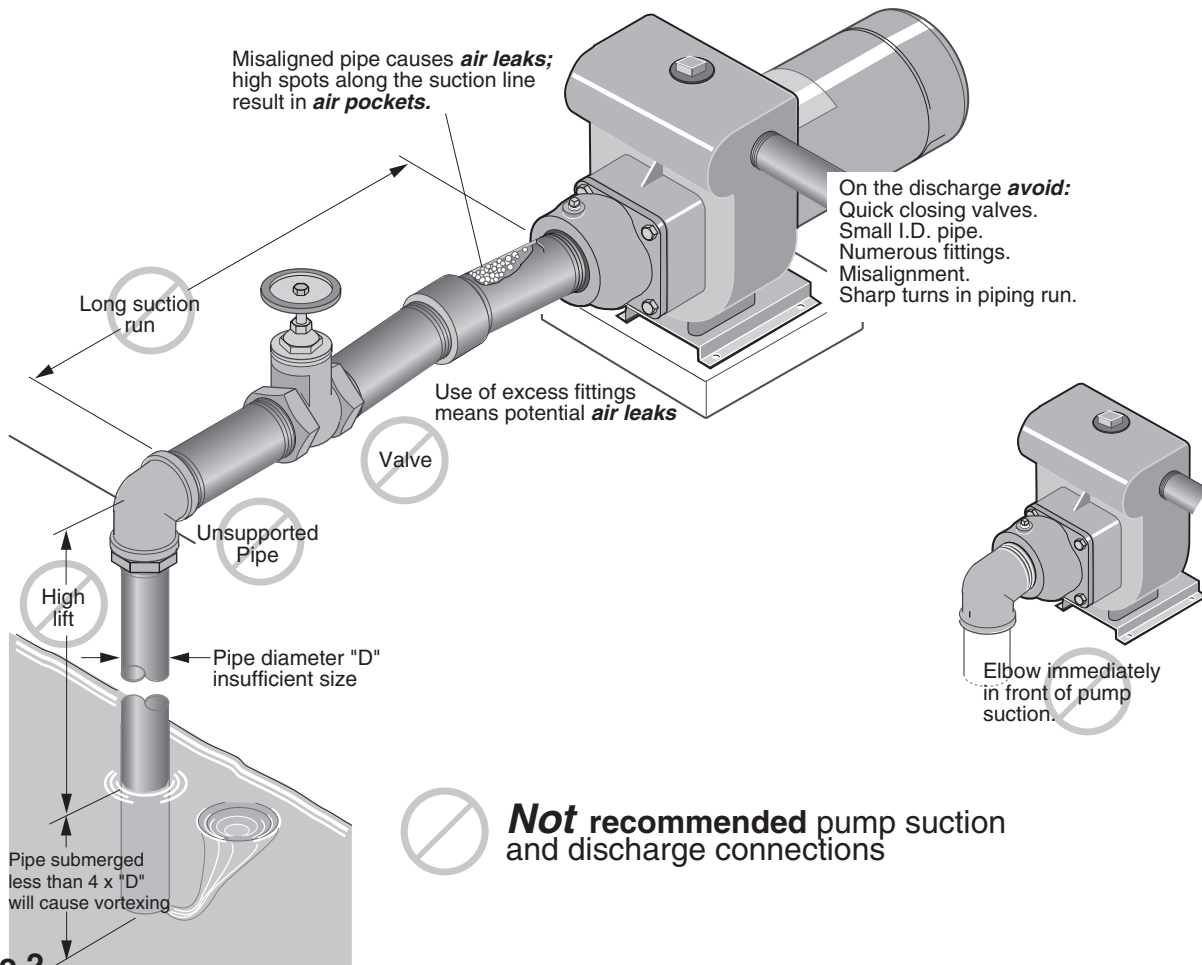

Figure 2

**California Proposition 65 Warning**

**▲ WARNING** This product and related accessories contain chemicals known to the State of California to cause cancer, birth defects or other reproductive harm.

**LOCATION OF UNIT**

Locate the pump as near the liquid source as possible, using a short, direct suction pipe. Keep the static suction lift (vertical distance between the center line of the pump and the liquid level) to a minimum. Mount the pump on a solid, level foundation, which provides a rigid and vibration-free support. It should be located where the unit is readily accessible for service and maintenance. The pump should be protected against flooding and excessive moisture. Do not allow pump or any system component to freeze.

**PIPING**

Both suction and discharge piping should be independently supported at a point near the pump to avoid strains being placed on the pump. Start all piping at pump to avoid strains left by a gap at last connection.

**SUCTION PIPING**

The suction pipe must be kept free of leaks. The suction pipe must have a gradual slope upward to the pump. Avoid any fittings which may cause an air trap. On units that have a suction fitting, a check valve is a built-in feature and no foot valve is required.

**DISCHARGE PIPING**

A gate valve and union should be installed in the discharge line. For removal of the pump for service, close the gate valve, and disconnect at union.

**▲ CAUTION** **Never run pump dry.** Running pump without water may cause pump to overheat, damaging seal and possibly causing burns to persons handling pump. Fill pump with water before starting.

**▲ WARNING** **Never run pump against closed discharge. To do so can boil water inside pump,** causing hazardous pressure in unit, risk of explosion and possibly scalding persons handling pump.

**PRIMING THE PUMP**

A tee installed in the discharge opening of the pump, and provided with a priming plug at the top position, will enable you to fill the pump with liquid. Once filled and the priming plug replaced, the pump will prime. The pump should prime itself time after time, as long as the built-in check valve functions.

**TABLE I - RECOMMENDED FUSING AND WIRING DATA - 60 CYCLE MOTORS**

MOTOR HP	MAX. LOAD AMPERES	BRANCH FUSE* RATING AMPS	DIAMETER IN FEET FROM MOTOR TO METER				
			0' TO 100'	101' TO 200'	201' TO 300'	301' TO 400'	401' TO 500'
			115/230 VOLT SINGLE PHASE WIRE SIZE				
1	15.3/7.6	20/15	12/14	8/14	6/14	6/12	4/10
1-1/2	19.2/9.6	25/15	10/14	8/14	6/12	4/10	4/10
2	24.0/12.0	30/15	10/14	6/14	6/12	4/10	4/10
2-1/2	26.0/12.0	30/15	10/14	16/14	4/12	4/10	4/10
<b>230/460 VOLT THREE PHASE WIRE SIZE</b>							
1	3.6/1.8	15/15	14/14	14/14	14/14	14/14	14/14
1-1/2	4.7/2.35	15/15	14/14	14/14	14/14	14/14	14/14
2	6.8/3.4	15/15	14/14	14/14	14/14	12/14	12/14
2-1/2	8.5/4.25	15/15	14/14	14/14	14/14	12/14	10/14
<b>200/400 VOLT THREE PHASE WIRE SIZE</b>							
1	3.8/1.9	15/15	14/14	14/14	14/14	14/14	14/14

\* Time delay fuse or circuit breakers are recommended in any motor circuit.

**IMPORTANT:** BE SURE lead wire opening on end of motor is fully sealed when conduit or a pressure switch is not used. Failure to seal it properly will allow dirt, rain, bugs, etc. to enter back compartment of motor through conduit opening and cause switch malfunction.

# ELECTRICAL

## Motor Terminal Block Wiring (as viewed from rear of motor, canopy removed)

Connection diagram for dual voltage, single-phase motors. Your dual-voltage motor's terminal board (under the motor end cover) will match one of the diagrams below. Follow that diagram if necessary to convert motor to 115 Volt power.

Connect power supply wires to L1 and L2. For 3-phase motors, or if motor does not match these pictures, follow the connection diagram on the motor nameplate.

### THE MOTOR IS SET FOR 230 VOLTS WHEN SHIPPED.

To change the motor to use 115 volts:

1. Turn off power
2. Remove the back motor cover.
3. Use a screwdriver or 1/2" wrench and turn the voltage selector dial counterclockwise until 115 shows in the dial opening.
4. Reinstall the motor cover.

**⚠ WARNING Hazardous voltage.** Can shock, burn, or cause death. Disconnect power to motor before working on pump or motor. Ground motor before connecting to power supply.



Figure 3: Changing the Voltage Setting



Figure 4: Motor Set for 115 Volt Operation

### WIRING

**⚠ Ground motor before connecting to electrical power supply. Failure to ground motor can cause severe or fatal electrical shock hazard.**

**⚠ Do not ground to a gas supply line.**

**⚠ To avoid dangerous or fatal electrical shock, turn OFF power to motor before working on electrical connections.**

**⚠ Supply voltage must be within  $\pm 10\%$  of nameplate voltage. Incorrect voltage can cause fire or damage motor and voids warranty. If in doubt consult a licensed electrician.**

**⚠ Use wire size specified in Wiring Chart (Page 3). If possible, connect pump to a separate branch circuit with no other appliances on it.**

**⚠ Wire motor according to diagram on motor nameplate. If nameplate diagram differs from diagrams above, follow nameplate diagram.**

1. Install, ground, wire and maintain this pump in accordance with electrical code requirements. Consult your local building inspector for information about codes.
2. Provide a correctly fused disconnect switch for protection while working on motor. Consult local or national electrical codes for switch requirements.
3. Disconnect power before servicing motor or pump. If the disconnect switch is out of sight of pump, lock it open and tag it to prevent unexpected power application.
4. Ground the pump permanently using a wire of the same size as that specified in wiring chart (Page 3). Make ground connection to green grounding terminal under motor canopy marked GRD. or  $(\text{E})$ .
5. Connect ground wire to a grounded lead in the service panel or to a metal underground water pipe or well casing at least 10 feet long. Do not connect to plastic pipe or insulated fittings.
6. Protect current carrying and grounding conductors from cuts, grease, heat, oil, and chemicals.
7. Connect current carrying conductors to terminals L1 and L2 under motor canopy. When replacing motor, check wiring diagram on motor nameplate against Figure 3. If the motor wiring diagram does not match either diagram in Figure 3, follow the diagram on the motor.

**IMPORTANT:** 115/230 Volt single phase models are shipped from factory with motor wired for 230 volts. If power supply is 115 volts, remove motor canopy and reconnect motor as shown in Figure 3. Do not try to run motor as received on 115 volt current.

8. Motor has automatic internal thermal overload protection. If motor has stopped for unknown reasons, thermal overload may restart it unexpectedly, which could cause injury or property damage. Disconnect power before servicing motor.

9. If this procedure or the wiring diagrams are confusing, consult a licensed electrician.

# SERVICE

## PUMP SERVICE

This centrifugal pump requires little or no service other than reasonable care and periodic cleaning. Occasionally, however, a shaft seal may become damaged and must be replaced. The procedure as outlined below will enable you to replace the seal.

**NOTICE: Pumps use mechanical seals with a rubber seat ring or a sealing O-Ring. THESE SEALS ARE COMPLETELY INTERCHANGEABLE.**

**NOTICE:** The highly polished and lapped faces of this seal are easily damaged. Read instructions and handle the seal with care.

Some models are equipped with an impeller screw, which has a left hand thread. Before unscrewing the impeller, remove the impeller screw.

### REMOVAL OF OLD SEAL

1. After unscrewing impeller, carefully remove rotating part of seal by prying up on sealing washer, using two screwdrivers (see Figure 5A). Use care not to scratch motor shaft.
2. Remove seal plate from motor and place on flat surface, face down. Use a screwdriver to push ceramic seat out from seal cavity (see Figure 5B).

### INSTALLATION OF STATIONARY SEAT (Figure 5C)

1. Clean polished surface of stationary seat with clean cloth.
2. Turn seal plate over so seal cavity is up, clean cavity thoroughly.
3. Lubricate outside rubber surface of ceramic seat

with soapy water and press firmly into seal cavity with finger pressure. If seat will not locate properly in this manner, place cardboard washer over polished face of seat and press into seal cavity using a 3/4" socket or 3/4" piece of standard pipe.

4. **DISPOSE OF CARDBOARD WASHER.** Be sure polished surface of seat is free of dirt and has not been damaged by insertion. Remove excess soapy water.

### INSTALLATION OF ROTATING PART OF SEAL UNIT (Figure 5D)

1. Reinstall seal plate using extreme caution not to hit ceramic portion of seal on motor shaft.
2. Inspect shaft to make sure that it is clean.
3. Clean face of sealing washer with clean cloth.
4. Lubricate inside diameter and outer face of rubber drive ring with soapy water and slide assembly on motor shaft (sealing face first) until rubber drive ring hits shaft shoulder.
5. Screw impeller on shaft until impeller hub hits shaft shoulder. This will automatically locate seal in place and move the sealing washer face up against seat facing. Reinstall impeller screw (if used).

### MAINTENANCE

Be sure to drain pump during freezing weather to prevent damage from frost. To drain, remove drain plugs directly below the suction inlet of the pump. Drain the suction pipe to a point below the frost line. All other pipes that may be exposed to freezing temperatures should also be drained.

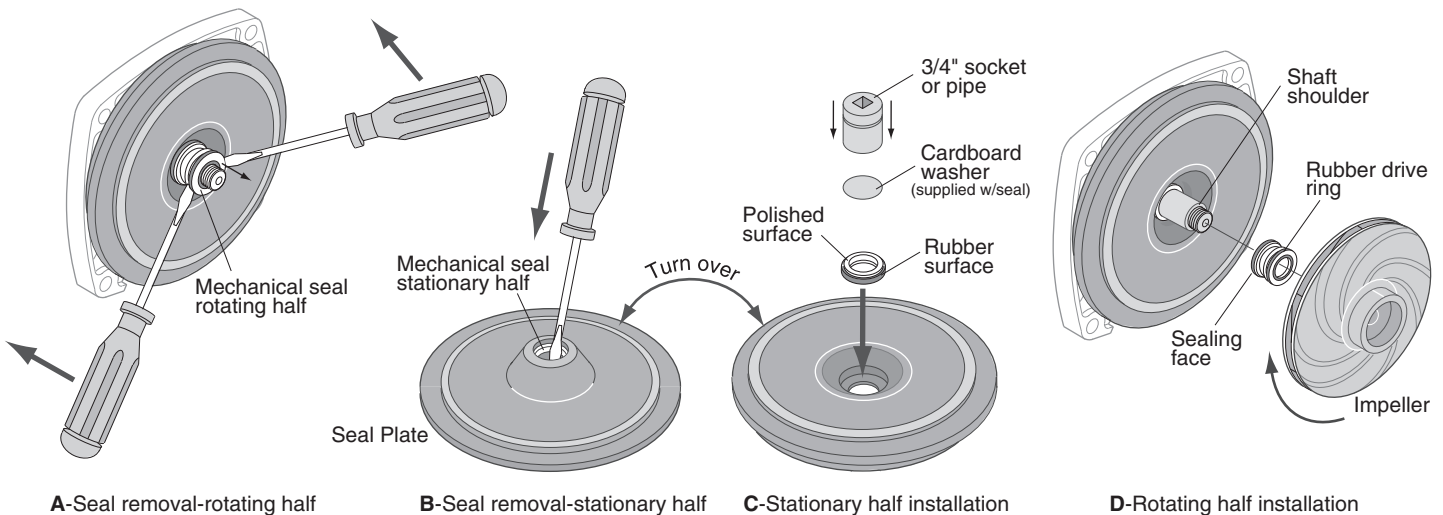
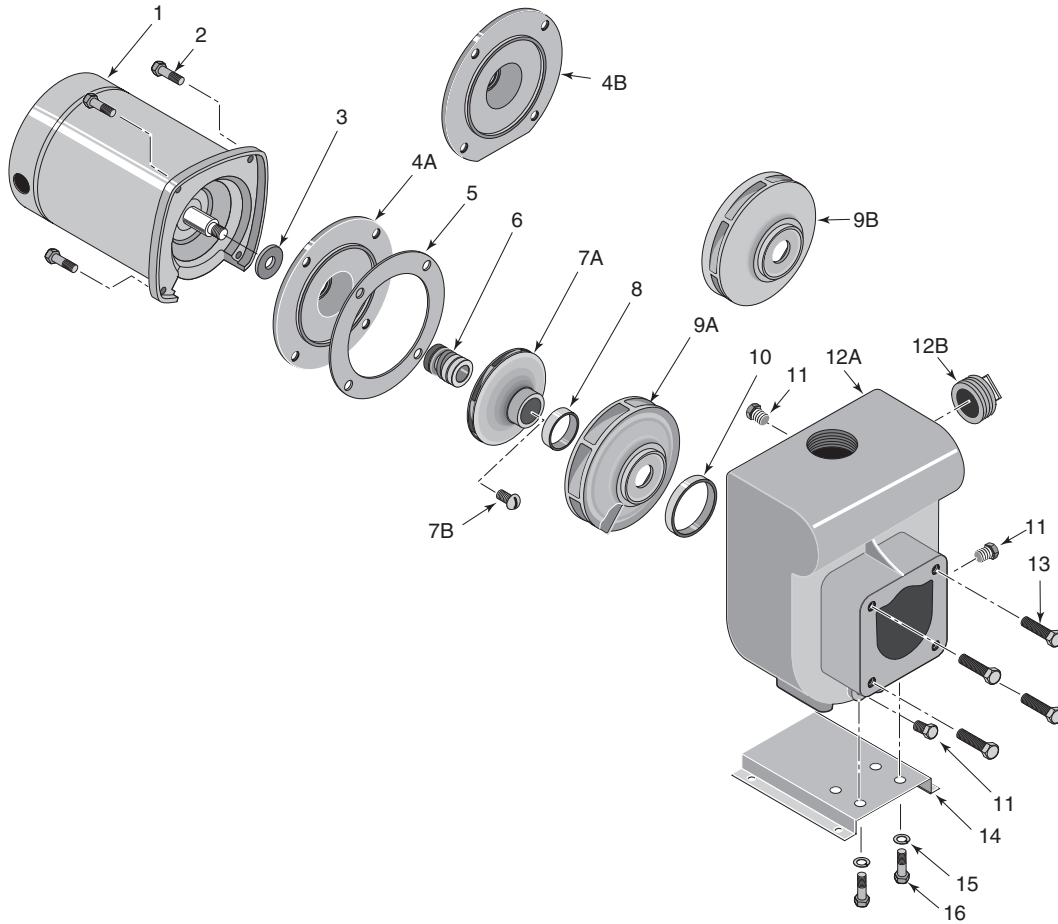

FIGURE 5





**“D” SERIES REPAIR PARTS LIST**  
**60 CYCLE 1 and 1-1/2 HP HIGH HEAD; 2 and 2-1/2 HP MEDIUM HEAD**

Key No.	Part Description	No. Used	1 HP DHE-50L DHE3-50 DH2E3-50	1-1/2 HP DHF-51L DHF3-51	2 HP DMG-41L DMG3-41	2-1/2 HP DMMG-42L DMMG3-42 DMM2G-42
1	Motor - 115/230V/60 Hz/1 Ph	1	A100ELL	A100FLL	—	—
1	Motor - 230V/60 Hz/1 Ph	1	—	—	AE100GLL	AE100G5LL
1	Motor - 230/460V/60 Hz/3 Ph	1	AP100EL	AP100FL	AP100GL	AP100G5L
1	Motor - 200/400V/60 Hz/3 Ph	1	AP100ELL	—	—	AP100G5L2
2	3/8 - 16 x 1-1/4" Cap Screw	4	U30-75ZP	U30-75ZP	U30-75ZP	U30-75ZP
3	Water Slinger	1	17351-0009	17351-0009	17351-0009	17351-0009
4A	Seal Plate	1	—	—	C3-23	C3-23
4B	Seal Plate	1	C3-52	C3-52	—	—
5	Seal Plate Gasket	1	C20-21	C20-21	C20-21	C20-21
6	Shaft Seal	1	U109-6A	U109-6A	U109-6A	U109-6A
7A	Impeller - (1 Phase)	1	C105-92PLC	C105-92PB	C105-114PNA	C105-80EA
7A	Impeller - (3 Phase)	1	C105-92PLA	C105-92PBA	C105-114PNA	C105-80EA
7B	Impeller Screw	1	C30-14SS*	C30-14SS*	C30-14SS	C30-14SS
8	Wear Ring	1	C23-27	C23-27	C23-32D	C23-32D
9A	Diffuser (Includes Key No. 8)	1	—	—	C101-56C	C101-72
9B	Diffuser (Includes Key No. 8)	1	C101-212B	C101-212B	—	—
10	Diffuser Ring	1	C21-2	C21-2	C21-2	C21-2
11	1/4 NPT Pipe Plug	3	U78-941ZPV	U78-941ZPV	U78-941ZPV	U78-941ZPV
12A	Pump Body	1	C76-1J	C76-1J	C76-1J	C76-1L
12B	1-1/2 NPT Pipe Plug	1	U78-63GPS	U78-63GPS	U78-63GPS	U78-63GPS
13	5/16 - 18 x 3/4" Cap Screw	4	U30-60ZP	U30-60ZP	U30-60ZP	U30-60ZP
14	Base	1	U4-5	U4-5	U4-5	U4-5
15	3/8" Lock Washer	2	U43-12ZP	U43-12ZP	U43-12ZP	U43-12ZP
16	3/8 - 16 x 5/8" Cap Screw	2	U30-71ZP	U30-71ZP	U30-71ZP	U30-71ZP

\*3 Phase only.

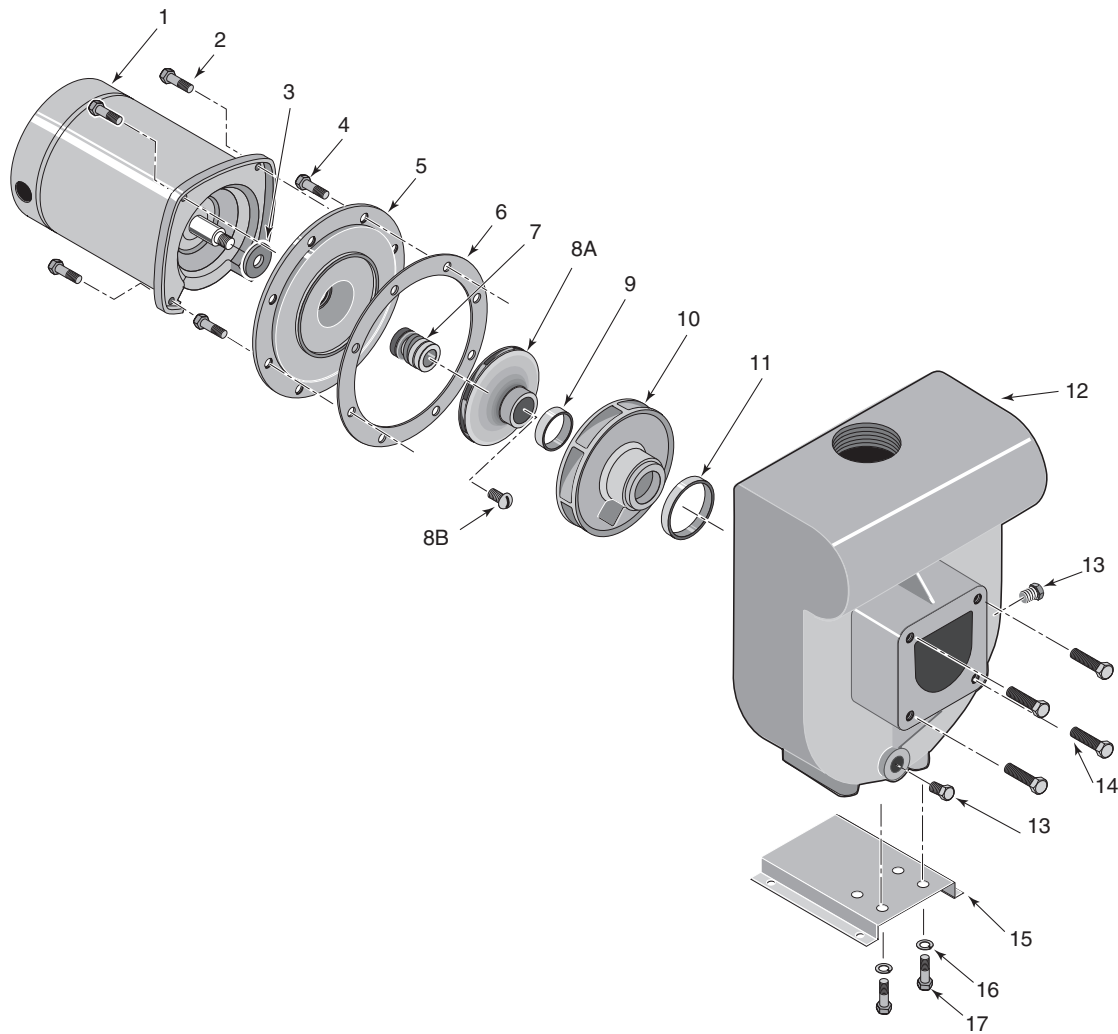

1442 1294

## “D” SERIES REPAIR PARTS LIST 60 CYCLE 2 and 2-1/2 HP HIGH HEAD

Key No.	Part Description	No. Used	2 HP	2-1/2 HP
			DHG-52L DHG3-52	DHHG-53L DHHG3-53
1	Motor - 230V/60 Hz/1 Ph	1	AE100GLL	AE100G5LL
1	Motor - 230/460V/60 Hz/3 Ph	1	AP100GL	AP100G5L
2	3/8 - 16 x 1" Cap Screw	4	U30-74ZP	U30-74ZP
3	Water Slinger	1	17351-0009	17351-0009
4	3/8 - 16 x 3/4" Cap Screw	8	U30-72ZP	U30-72ZP
5	Seal Plate	1	C103-35	C103-35
6	Seal Plate Gasket	1	C20-46	C20-46
7	Shaft Seal	1	U109-6A	U109-6A
8A	Impeller	1	C105-214PCA	C105-214PA
8B	Impeller Screw	1	C30-14SS	C30-14SS
9	Wear Ring	1	C23-19	C23-19
10	Diffuser (Includes Key No. 9)	1	C101-77	C101-77
11	Diffuser Ring	1	C21-2	C21-2
12	Pump Body	1	C76-12	C76-12
13	1/4 NPT Drain Plug	2	U78-941ZPV	U78-941ZPV
14	5/16 - 18 x 3/4" Cap Screw	4	U30-60ZP	U30-60ZP
15	Base	1	U4-5	U4-5
16	3/8" Lock Washer	2	U43-12ZP	U43-12ZP
17	3/8 - 16 x 5/8" Cap Screw	2	U30-71ZP	U30-71ZP

## Suction Flange Assemblies

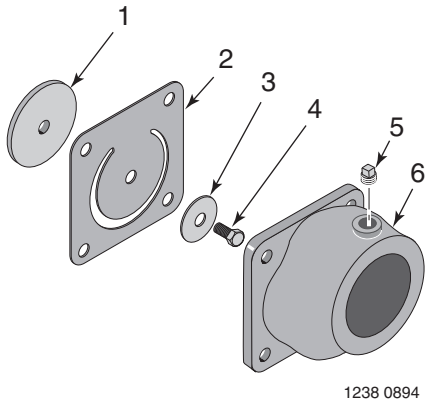

Key No.	Part Description	No. Used	Part Symbol
1	Valve Plate	1	C61-5SS
2	Gasket - Flange	1	C20-15
3	Valve Washer	1	C43-15SS
4	Machine Screw 1/4-20 x 1/2"	1	U30-50SS
5	Pipe Plug - 1/4" NPT Sq. Hd.	1	U78-57SSS
6	Suction Flange 1-1/2" NPT	1	C3-22
6	Suction Flange 2" NPT	1	C3-22A
•	Nut, 1/4-20, Hex	1	BC120-15
	Suction Flange Assembly- Complete 1-1/2" NPT		C203-22
	Suction Flange Assembly- Complete 2" NPT		C203-22A

<b>TROUBLE - CAUSES AND REMEDY</b>	
<b>TROUBLE AND CAUSE</b>	<b>REMEDY</b>
<b>FAILURE TO PUMP</b>	
1. Pump not properly primed.	1. Make sure pump casing and suction line are full of water. See priming instructions.
<b>REDUCED CAPACITY AND/OR HEAD</b>	
1. Air pockets or leaks in suction line.	1. Check suction piping.
2. Clogged impeller.	2. Remove and clean.
<b>PUMP LOSES PRIME</b>	
1. Air leaks in suction line.	1. Check suction piping
2. Excessive suction lift and operating too near shut-off point.	2. Move pump nearer to water level.
3. Water level drops while pumping, uncovering suction piping.	3. Check water supply. Add length of pipe to suction to keep submerged end under water.
<b>MECHANICAL TROUBLES AND NOISE</b>	
1. Bent shaft and/or damaged bearings.	1. Take motor to authorized motor repair shop.
2. Suction and/or discharge piping not properly supported and anchored.	2. See that all piping is supported to relieve strain on pump assembly.