

EOM

Engineering
Operation &
Maintenance

WILDEN®

VELOCITY PLASTIC PUMP

PUMP DESIGNATION SYSTEM



MATERIAL CODES

MODEL

V2550 = 6 mm (1/4") VELOCITY
A2550V = 6 mm (1/4") ACCU-FLO™

WETTED PARTS & OUTER PISTON

KK = PVDF / PVDF
PP = POLYPROPYLENE / POLYPROPYLENE

AIR CHAMBER/CENTER BLOCK

PP = POLYPROPYLENE

AIR VALVE

A = ALUMINUM (ACCU-FLO Only)
E = PET

LEGEND

V2550 / XXXXX / XXX / XX / XXX / XXXX

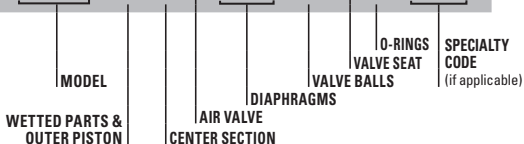

DIAPHRAGMS

TSS = FULL-STROKE PTFE W/ SANIFLEX
BACK-UP O-RING
ZWS = WIL-FLEX™ [Santoprene®
(Three Black Dots)]

VALVE BALLS

TF = PTFE (White)
WF = WIL-FLEX™ [Santoprene®
(Three Black Dots)]

VALVE SEAT

K = KYNAR
P = POLYPROPYLENE

VALVE SEAT O-RING

TV = PTFE-ENCAP. FKM
WF = WIL-FLEX (Santoprene®)

SPECIALTY CODES

0150 Accu-Flo, 24V DC Coil
0151 Accu-Flo, 24V AC/12V Coil
0155 Accu-Flo, 110V AC Coil

CAUTIONS & WARNINGS



PUMP TEMPERATURE LIMITS:

PVDF and Polypropylene 4°C – 79°C (40°F - 175°F)



CAUTION: Maximum temperature limits are based upon mechanical stress only. Certain chemicals will significantly reduce maximum safe operating temperatures. Consult Chemical Resistance Guide for chemical compatibility and temperature limits.



CAUTION: Do not exceed 6.9 bar (100 psig) air supply pressure.



CAUTION: Verify the chemical compatibility of the process and cleaning fluid to the pump's component materials in the Wilden Chemical Resistance Guide.



CAUTION: Plastic series pumps are made from plastic that is not UV-stabilized. Direct sunlight exposure for prolonged periods can cause deterioration of plastic.



CAUTION: V2550 pumps are not submersible.



CAUTION: Always wear safety glasses when operating pump. If diaphragm rupture occurs, fluid being pumped may be forced out air exhaust.



WARNING: Before any maintenance or repair is attempted, the compressed air line to the pump should be disconnected and all air pressure allowed to bleed from the pump.



WARNING: Ensure that the air supply line is clear of debris. Use of a 5 μ (micron) in-line air filter is recommended.

DIMENSIONAL DRAWING

V2550 PLASTIC

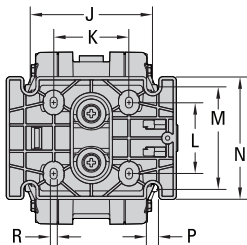
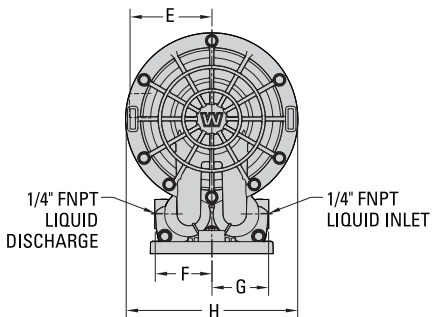
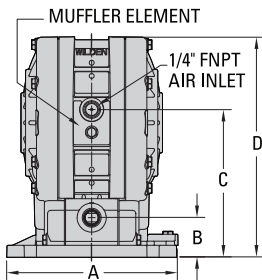

DIMENSIONS

ITEM	METRIC (mm)	STANDARD (inch)
A	138	5.4
B	32	1.3
C	119	4.7
D	177	7.0
E	66	2.6
F	46	1.8
G	46	1.8
H	138	5.4
J	98	3.9
K	60	2.4
L	57	2.2
M	83	3.3
N	98	3.9
P	10	0.4
R	6	0.2

LW0351 REV. D

WIL-41000-E-06

DIMENSIONAL DRAWING

V2550 PLASTIC - HORIZONTAL

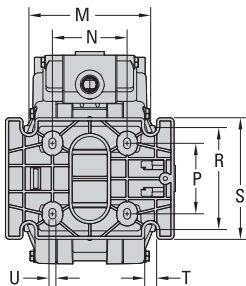
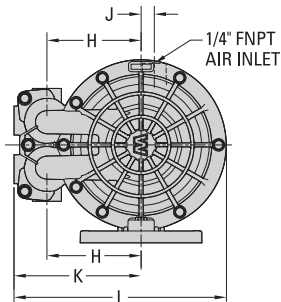
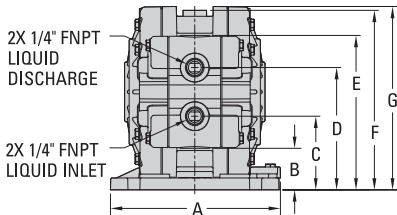

DIMENSIONS

ITEM	METRIC (mm)	STANDARD (inch)
A	138	5.4
B	34	1.3
C	60	2.4
D	99	3.9
E	125	4.9
F	145	5.7
G	148	5.8
H	76	3.0
J	11	0.4
K	103	4.1
L	172	6.8
M	98	3.9
N	60	2.4
P	57	2.2
R	83	3.3
S	98	3.9
T	10	0.4
U	6	0.2

LW0352 REV. C

WIL-41000-E-06

DIMENSIONAL DRAWING

A2550V PLASTIC

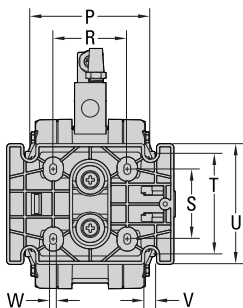
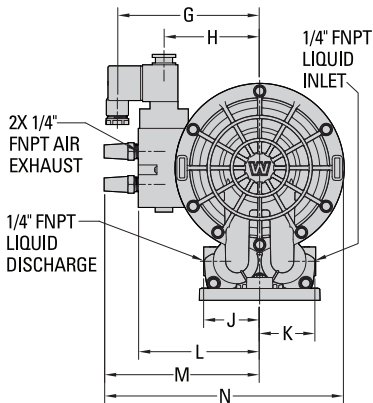
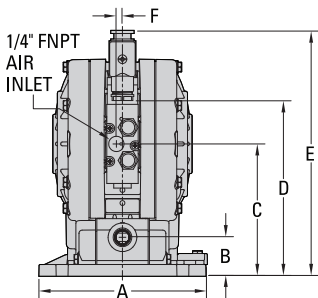

DIMENSIONS

ITEM	METRIC (mm)	STANDARD (inch)
A	138	5.4
B	32	1.3
C	108	4.3
D	143	5.6
E	201	7.9
F	5	0.2
G	116	4.6
H	78	3.1
J	46	1.8
K	46	1.8

ITEM	METRIC (mm)	STANDARD (inch)
L	99	3.9
M	127	5.0
N	196	7.7
P	98	3.9
R	60	2.4
S	57	2.2
T	83	3.3
U	98	3.9
V	10	0.4
W	6	0.2

LW0353 REV. D

V2550 DRY SUCTION-LIFT CURVE

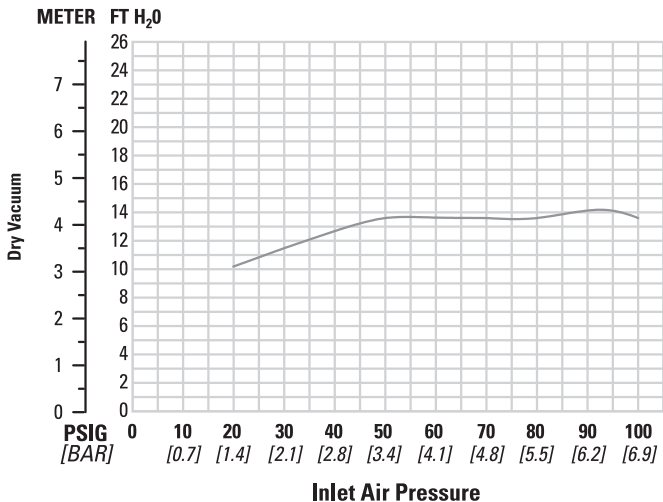

Suction-lift curves are created using pumps operating at 305 m (1000') above sea level. This chart is meant to be a guide only. There are many variables which can affect the pump's operating characteristics.

Suction lift can be affected by the number of intake/discharge elbows, viscosity of pumping fluid, elevation (atmospheric pressure), pipe friction losses and other factors.

Caution: Do not exceed 6.9 bar (100 psig) air supply pressure.

A2550V PERFORMANCE CURVE

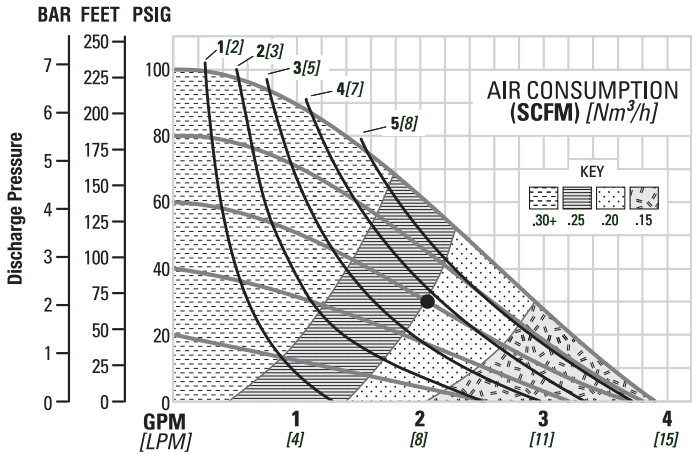

Ship Weight2 kg (4 lb)
 Air Inlet 6 mm (1/4")
 Inlet 6 mm (1/4")
 Outlet 6 mm (1/4")
 Suction Lift4.3 m Dry (14.2')
 6.2 m Wet (20.4')
 Disp. per Stroke¹ 0.04 L (0.01 gal)
 Max. Flow Rate 14.8 lpm (3.9 gpm)
 Max. Size Solids..... 0.8 mm (1/32")

¹Displacement per stroke was calculated at 4.8 bar (70 psig) air inlet pressure against a 2.1 bar (30 psig) head pressure.

Example: To pump 7.9 lpm (2.1 gpm) against a discharge head of 2.1 bar (30 psig) requires 4.1 bar (60 psig) and 6.6 Nm³/h (3.9 scfm) air consumption.

Caution: Do not exceed 6.9 bar (100 psig) air supply pressure.

A2550V 70/30 OPERATING CONDITION

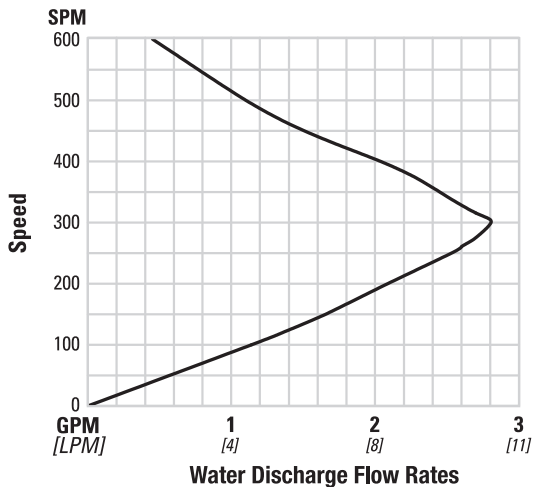

This curve demonstrates the flow created when the stroke rate is varied under static air and fluid pressure conditions. This curve can be applied to different pressure conditions to estimate the change in flow due to stroke rate.

SUGGESTED INSTALLATION

PUMP SELECTION: Ensure that the pump materials of construction are compatible with the pumping media and the immediate surroundings the pump will be subjected to. Refer to the Wilden Chemical Resistance Guide. For optimum life and performance, the pump size should be specified so that daily operation parameters are not near the pump's maximum rated performance capabilities.

INSTALLATION: The Velocity pump has two foot-mount configurations and can be mounted in any orientation. The pump can be mounted in place or left free standing for use in multiple locations. If the pump is to be mounted in place, it is suggested to attach the Base Assembly to the desired horizontal or vertical surface using four (4) screws (not supplied) and then attach the pump to the Base Assembly (See Assembly Instructions).

The Velocity pump has two inlet fluid connections and two discharge fluid connections. One inlet and discharge connection must be plugged using the supplied NPT plugs.

PIPING: The suction and discharge piping diameter should be equivalent or larger than the diameter of pump connection, the length and complexity of the suction and discharge piping should be minimized, unnecessary elbows, bends and fittings should be avoided, all in an effort to reduce friction losses.

The suction hose must be non-collapsible. If rigid piping is used, it should be supported independently of the pump. In addition, the piping should be aligned to avoid placing stress on the pump fittings.

When used in self-priming applications, it is critical that all fittings and connections are airtight or a reduction or loss of pump suction capability will result. Ensure that the suction lift requirement is within the pump model's capability.

AIR SUPPLY: Every pump should have an airline large enough to supply the volume of air necessary to achieve the desired pumping rate. Air pressure to the pump should not exceed a maximum of 6.9 bar (100 psig). For best results, the pumps should use a 5 μ (micron) air filter to eliminate air-line contaminants, a needle valve and pressure regulator.

SOLENOID CONTROL: When start-stop operation of a standard air valve equipped pump is controlled by a solenoid valve in the air line, a three-way (3/2) solenoid valve should be used to vent pressurized air between the solenoid and pump when the pump is stopped.

PUMP OPERATION: Once installation is complete, pump operation can be started by opening the air shut-off valve (do not exceed the pump's maximum rated pressure). The pressure regulator and needle valve are used to adjust the speed of the pump.

BASIC TROUBLESHOOTING

Pump will not run or runs slowly:

1. Ensure the air inlet pressure is 0.3 bar (5 psig) above the start-up pressure of the pump.
2. Ensure the differential pressure (difference between the air inlet pressure and fluid discharge pressure) is not less than 0.7 bar (10 psig).
3. Check air line/filter for blockage/debris. Check for obstruction in the air passageways of the pump.
4. Check for objects in the pump that would obstruct the movement of internal parts.
5. Check for severe air leakage (blow-by) coming from the air exhaust. This could indicate a failed O-ring seal or worn air valve assembly.
6. Inspect for check valve failure. A worn check ball can get stuck in the seat. A check ball can swell and become stuck if not compatible with fluid pumped. Replace if necessary.

Pump runs but little or no product flows:

1. Check for cavitation. Confirm vacuum required to lift the fluid is not greater than the vapor pressure of the fluid being pumped. Slow pump speed to allow viscous fluids to flow into liquid chambers.
2. Ensure that the suction lift requirement is within the pump model's capability.
3. Inspect for check valve failure. A worn check ball can get stuck in the seat. A check ball can swell and become stuck if not compatible with fluid pumped. Replace if necessary.

Air bubbles in pump discharge:

1. Check for ruptured diaphragm.
2. Check tightness of outer piston to shaft.
3. Check integrity of O-ring seals, especially intake side of manifold.
4. Ensure pipe connections are airtight.

Product comes out of air exhaust:

1. Check for ruptured diaphragm.
2. Check tightness of outer piston to shaft.

DISASSEMBLY / REASSEMBLY

Tools Required:

- 5/16" Socket Wrench
- 7/16" Socket Wrench
- Snap-Ring Pliers

CAUTION: Before any maintenance or repair is attempted, the compressed air line to the pump should be disconnected and all air pressure allowed to bleed from the pump.

1. Insert the smaller end of the air valve assembly (item 1) into center section (item 5) until fully seated. Install retaining ring (item 6) in groove on air valve assembly.
2. Install backup O-rings (item 20) on to surfaces of center section (item 5).
3. Slide washer (item 18) and inner pistons (item 19) on to ends of shaft.
4. Slide diaphragms (item 21) on to ends of shaft.
5. Install outer pistons (item 22) on to ends of shaft. Tighten to specified torque (50 lb-in). Over-tightening could damage outer piston.
6. Install four (4) ball check cartridges (item 15) into manifold (item 13). **NOTE:** The cartridges must be installed in correct orientation. Align grooves on cartridge with ribs in manifold. Cartridge will be flush with end of the manifold if installed correctly.
7. Install four (4) manifold O-rings (item 16) on to ends of manifold (item 13).
8. Place upper screw boss in manifold (item 13) in-between the flanges at the bottom of the center section (item 5).
9. Place the center section-manifold assembly between two liquid chambers (item 12), taking care to align the large bore on liquid chamber over the diaphragm and the two (2) small bores over the manifold.
10. Place in a vise and carefully press assembly together. Take care not to pinch or damage sealing O-rings. There should be a consistent 0.05" gap between the center section (item 5) and liquid chambers (item 12).
11. Fasten liquid chambers (item 12) to center section (item 5) and manifold (item 13) using (22) #10 screws (item 10). Tighten fasteners to specified torque (35 lb-in). Over-tightening fasteners could damage center section.
12. Press muffler element (item 9) into muffler cavity (near air inlet) of center section (item 5). Hold muffler element in place using one (1) #10 screw (item 10).
13. There are two mounting options for the base assembly (item 23).
14. Install one (1) NPT plug (item 14) into one (1) inlet port of the manifold (item 13). Install one (1) NPT plug into one (1) discharge port on manifold.



STEP 1



STEP 1

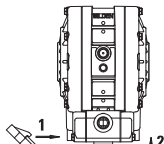

VERTICAL MOUNTING

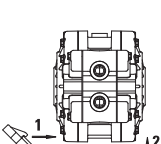

HORIZONTAL MOUNTING



STEP 3 - Slide attachment tab (item 24) forward into slot on liquid chamber.

STEP 4 - Tighten mount screw (item 25) to secure attachment tab (item 24) in place.

STEP 1 - Slide tab on base assembly (item 23) into desired slot in liquid chamber (item 12).

STEP 2 - Rotate base into position.

EXPLODED VIEW

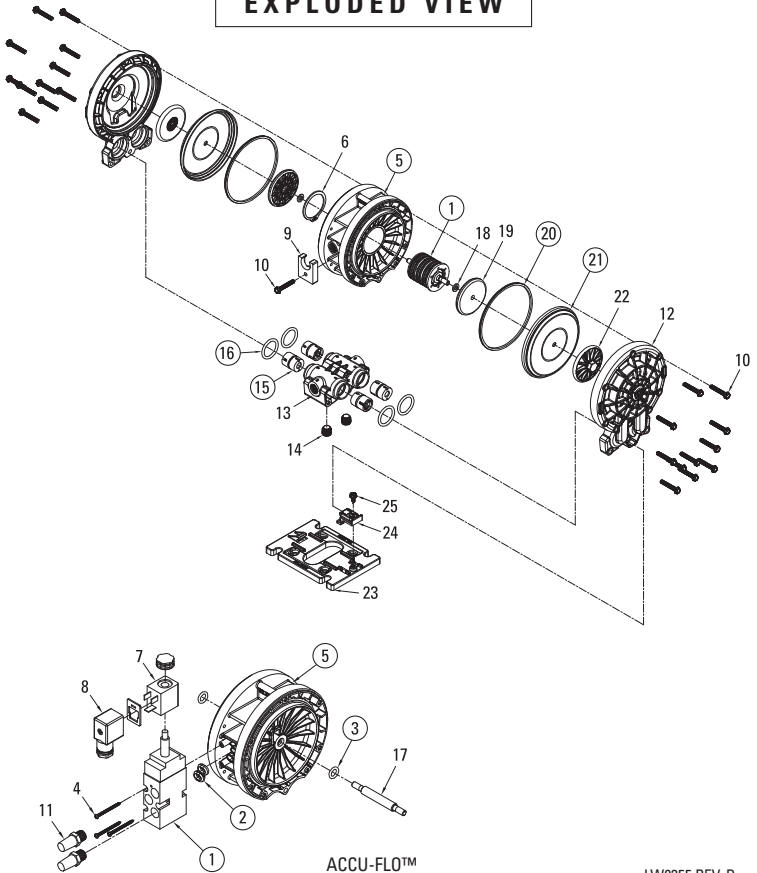

ACCU-FLO™

LW0355 REV. D

ALL CIRCLED PART IDENTIFIERS ARE INCLUDED IN REPAIR KITS

WIL-41000-E-06

PARTS LISTING

Item	Description	Qty.	V2550 /PPPE/.../P/N	A2550V /PPPPA/.../P/N	V2550 /KKPPE/.../P/N	A2550V /KKPPA/.../P/N
AIR DISTRIBUTION COMPONENTS						
1	Air Valve Assembly¹	1	00-2044-99		00-2044-99	
	Air Valve Assembly, Solenoid²	1		00-2014-99		00-2014-99
2	Gasket, Solenoid Valve	1		00-2640-56		00-2640-56
3	O-Ring, Shaft (-110, Ø.362" x Ø.103")	2		15-2650-49		15-2650-49
4	Screw, Hex Washer Head Torx, Solenoid Air Valve (#4-24 x 1 1/4")	3		00-6134-03		00-6134-03
5	Center Section Assembly, Air Valve³	1	00-3171-20		00-3171-20	
	Center Section Assembly, Accu-Flo™⁴	1		00-3169-20		00-3169-20
6	Retaining Ring	1	00-2644-09	N/A	00-2644-09	N/A
7	Coil, 24V DC	1		00-2110-99-150		00-2110-99-150
	Coil, 24V AC / 12V DC	1		00-2110-99-151		00-2110-99-151
	Coil, 110V AC	1		00-2110-99-155		00-2110-99-155
8	Connector, Solenoid	1		00-2130-99		00-2130-99
9	Muffler Element	1	00-3244-26		00-3244-26	
10	Screw, Hex Washer Head Tri-Lobe (#10-14 x 1-1/4")	1	00-6114-03		00-6114-03	
11	Muffler, 1/4" MNPT	2		04-3240-07		04-3240-07
WETTED PATH COMPONENTS						
12	Liquid Chamber	2	00-5014-20		00-5014-21	
13	Manifold, Four Port, 1/4" (NPT)	1	00-5164-20		00-5164-21	
14	Manifold Pipe Plug 1/4" (NPT)	2	00-7014-20		00-7014-21	
10	Screw, Hex Washer Head Tri-Lobe (#10-14 x 1-1/4")	22		00-6114-03		
BALL CHECK CARTRIDGE / MANIFOLD O-RINGS						
15	Ball Check Cartridge	4		*		*
16	Manifold O-Ring, TPE Fitted (-214, Ø.984 x Ø.139")	4		*		*
	Manifold O-Ring, PTFE Fitted (-214, Ø.984 x Ø.139")	4		*		*
FULL-STROKE RUBBER / TPE / PTFE COMPONENTS						
17	Shaft	1		00-3849-03		00-3849-03
18	Washer, Inner Piston (Ø.255" x Ø.468" x .060")	2		00-6844-03		
19	Piston, Inner	2		00-3740-20		
20	Diaphragm, Back-Up Seal PTFE only	2		*		
21	Diaphragm, Primary	2		*		
22	Piston, Outer	2	00-4640-20	00-4640-20	00-4640-21	00-4640-21
REMOVABLE FOOT COMPONENTS						
23	Base, Removable Assembly ⁵	1		00-5540-99		
24	Attachment Tab, Removable Base	1		00-5544-20		
25	Screw, Slotted Hex Washer Head Tapping (#10-12 x 1/2")	1		00-6124-03		

* See Elastomer Options

¹ Air Valve Assembly includes item 6 and 9.

² Accu-Flo™ Air Valve Assembly includes items 2, 4, 7, 8 and 11.

³ Air Valve Center Section Assembly includes items 1, 6, 9 and 10.

⁴ Accu-Flo™ Center Section Assembly includes items 1, 2, 3, 4, 7, 8, 11 and 17.

⁵ Removable Base Assembly includes items 24 and 25.

All boldface items are primary wear parts.

LW0356 Rev. F

WIL-41000-E-06

ELASTOMER OPTIONS

MATERIAL	DIAPHRAGMS (2)	DIAPHRAGM BACK-UP SEAL (2)	POLY BALL CHECK CARTRIDGE (4)	PVDF BALL CHECK CARTRIDGE (4)	MANIFOLD O-RINGS (4)
PTFE	00-1044-55		00-9189-55	00-9188-55	
Saniflex™		00-1074-56			
Wil-Flex™	00-1044-58		00-9189-58	00-9188-58	38-1371-58
PTFE-Encapsulated FKM					38-1371-60

LW0356 Rev. F

MAXIMUM TORQUE SPECIFICATIONS

VELOCITY MAXIMUM TORQUE SPECIFICATIONS

Description of Part	Torque
Liquid Chamber – Center Section (#10)	4.5 N•m (40 in-lb)
Outer Piston	5.6 N•m (50 in-lb)
Solenoid - Center Section (#4)	1.6 N•m (15 in-lb)

WARRANTY

Each and every product manufactured by Wilden Pump & Engineering, LLC is built to meet the highest standards of quality. Every pump is functionally tested to insure integrity of operation. Wilden Pump & Engineering, LLC warrants that pumps, accessories and parts manufactured or supplied by it to be free from defects in material and workmanship for a period of five (5) years from date of installation or six (6) years from date of manufacture, whichever comes first. Failure due to normal wear, misapplication, or abuse is, of course, excluded from this warranty. Since the use of Wilden pumps and parts is beyond our control, we cannot guarantee the suitability of any pump or part for a particular application and Wilden Pump & Engineering, LLC shall not be liable for any consequential damage or expense arising from the use or misuse of its products on any application. Responsibility is limited solely to replacement or repair of defective Wilden Pump & Engineering, LLC. All decisions as to the cause of failure are the sole determination of Wilden Pump & Engineering, LLC. Prior approval must be obtained from Wilden for return of any items for warranty consideration and must be accompanied by the appropriate MSDS for the product(s) involved. A Return Goods Tag, obtained from an authorized Wilden distributor, must be included with the items which must be shipped freight prepaid. The foregoing warranty is exclusive and in lieu of all other warranties expressed or implied (whether written or oral) including all implied warranties of merchantability and fitness for any particular purpose. No distributor or other person is authorized to assume any liability or obligation for Wilden Pump & Engineering, LLC other than expressly provided herein.

WILDEN[®]

22069 VAN BUREN STREET • GRAND TERRACE, CA 92313-5607
(909) 422-1700 • FAX (909) 783-3440
www.wildenpump.com

