

Please read and save this Repair Parts Manual. Read this manual and the General Operating Instructions carefully before attempting to assemble, install, operate or maintain the product described. Protect yourself and others by observing all safety information. The Safety Instructions are contained in the General Operating Instructions. Failure to comply with the safety instructions accompanying this product could result in personal injury and/or property damage! Retain instructions for future reference. AMT reserves the right to discontinue any model or change specifications at any time without incurring any obligation.

©2016 AMT Pump Company, A Subsidiary of The Gorman-Rupp Company, All Rights Reserved.

Periodic maintenance and inspection is required on all pumps to ensure proper operation. Unit must be clear of debris and sediment. Inspect for leaks and loose bolts. Failure to do so voids warranty.

2-Inch Trash Pedestal Pumps



Refer to pump manual 1808-635-00 for General Operating and Safety Instructions.

DESCRIPTION

This self-priming (to 20 ft. lift) centrifugal pump includes a clog-resistant, open impeller capable of handling solids as large as 1" diameter (up to 25% by volume). A built-in check valve assists in priming and a mechanical seal prevents leakage. All seals are Buna-N. Handles liquids from 40° to 180° F (4° to 82° C). For use with nonflammable liquids compatible with pump component materials.

MAINTENANCE

▲ WARNING

Make certain that unit is disconnected from power source before attempting to service or remove any component!

CLEANING

This unit has been designed with a removable volute enabling pump to be cleaned or unclogged with ease. Remove casing and volute as described in steps 1 and 2 under MECHANICAL SEAL REPLACEMENT. Remove any debris found inside unit, reassemble as described in steps 16 and 17 under MECHANICAL SEAL REPLACEMENT.

NOTE: Depending on application, it may be necessary to remove suction and discharge hoses.

MECHANICAL SEAL REPLACEMENT

Refer to Figures 1 and 2.

IMPORTANT: Always replace seal seat (Ref. No. 12), seal head (Ref. No. 13), and shaft sleeve (Ref. No. 14) to ensure proper mating of mechanical seal components!

1. Unthread cap screws (Ref. No. 22) and remove casing (Ref. No. 20) and o-ring (Ref. No. 11) from adapter (Ref. No. 10).
2. Unthread round head screws (Ref. No. 17) and remove volute (Ref. No. 18) from adapter.
3. Unscrew impeller (Ref. No. 9) from pump shaft (Ref. No. 5). Remove impeller shim(s) (Ref. No. 15), shaft sleeve and seal head from pump shaft.
4. Unthread hex flange screw (Ref. Nos. 7 & 8) and remove adapter from pedestal mounting face.
5. Push seal seat from adapter recess with a screwdriver.
6. Clean adapter recess before inserting a new seal seat.
7. Carefully wipe polished surface of new seal seat with a clean cloth.
8. Wet the outside of rubber portion of seal seat with a light coating of soapy water.
9. Press new seal seat squarely into cavity in adapter. Use finger pressure

only to avoid scratching seal seat. (This is a lapped surface and must be handled very carefully.)

10. After seal seat is in place, be sure that it is clean and has not been marred.
11. Using a clean cloth, wipe shaft and make certain that it is perfectly clean.
12. Secure adapter on pedestal mounting face.

▲ CAUTION

Tighten hex flange screws EVENLY to avoid cocking rabbet on pedestal mounting face.

13. Apply a light coating of soapy water to inside rubber portion of seal head and slide onto shaft sleeve. Slip shaft sleeve with seal head onto pump shaft with polished face toward seal seat.

▲ CAUTION

Do not touch or wipe face of polished surface part of seal head.

14. Replace any impeller shim(s) removed in disassembly.
15. Screw impeller back in place, tightening until it is against shaft sleeve.
16. Remount volute and position o-ring in place.

IMPORTANT: Always inspect o-ring. Replace when cracked or worn. Wet o-ring with soapy water for ease of assembly.

17. Remount casing.

BEARING HOUSING SERVICE

1. Remove front pump assembly as described under "Mechanical Seal Replacement"
2. Remove shaft bearing (Ref. No. 3) and shaft (Ref. No. 5) as an assembly by first removing retaining ring (Ref. No. 1). Push shaft bearing assembly out of pedestal (Ref. No. 6) by rapping on threaded end of shaft with a rawhide mallet or block of wood and a hammer.
3. Ball bearings can now be removed from shaft.
4. If shaft bearings have been removed from shaft, replace by sliding bearing on shaft to shoulder. Replace shaft bearing assembly by sliding assembly into housing threaded end first. Push shaft bearing assembly completely in by gently tapping on keyway end of shaft with a rawhide mallet. Replace retaining ring.
5. Reassemble pump as described in "Mechanical Seal Replacement".

Performance Chart

Power Requirement	GPM of Water at Total Head in Feet									Max** Head
	10'	20'	30'	40'	50'	60'	70'	80'	92 ft.	
5HP @3600 RPM	155	145	134	123	110	90	65	40	92 ft.	

(**) Shutoff; to convert to psi, divide by 2.31.

2-Inch Trash Pedestal Pumps

SHIM ADJUSTMENT

1. When installing a replacement adapter (Ref. No.10), impeller (Ref. No. 16), shaft sleeve (Ref. No. 14), volute (Ref. No. 18) or casing (Ref. No. 20) it may be necessary to vary the number of impeller shims (Ref. No. 15) that will be required. This is easily done by adding one shim more than was removed and reassembling pump as described in MECHANICAL SEAL REPLACEMENT section.

NOTE: When adding or removing shims, it is best to proceed with a 0.010" increment each time. While tightening unit together turn shaft; feel for shaft seizing. If shaft begins to seize before fasteners are completely tight, disassemble pump and remove one shim and repeat assembly.

2. Once having added one shim more than original, ensure that volute and adapter are firmly fitted (check fasteners Ref. No. 17). When pump shaft turns freely add shims until it does strike, then remove a 0.010" shim. This should allow proper clearance.
3. Proper running clearance for impeller should be as close as possible to volute without striking; maximum clearance is 1/32" (0.032").
4. Follow above procedure until proper clearance is obtained. This will ensure maximum performance.

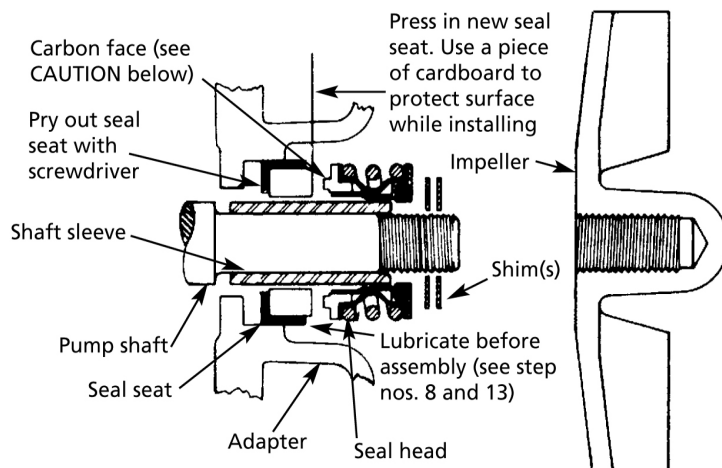

Figure 1 - Mechanical Seal Replacement

For Repair Parts contact dealer where pump was purchased.

Please provide following information:

-Model Number

-Serial Number (if any)

Part description and number as shown in parts list

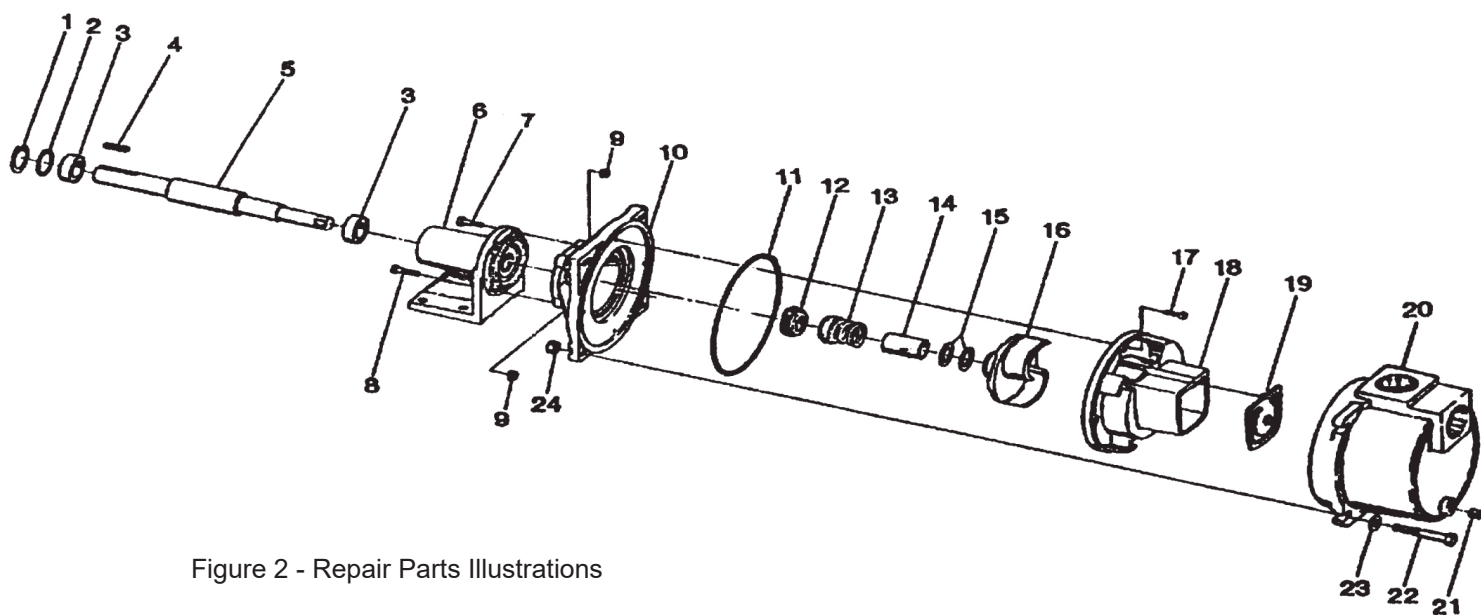

Figure 2 - Repair Parts Illustrations

2-Inch Trash Pedestal Pumps

Repair Parts List

Ref No.	Description	Part Numbers for 3931-99	Qty
1	Retaining Ring	1695-034-00	1
2	Bearing Shim Set	1696-008-90	1
3	Ball Bearing	1695-031-00	2
4	Key	1517-000-00	1
5	Shaft	1695-001-00	1
6	Pedestal	1695-030-01	1
7	Fastener	*	2
8	Fastener	*	2
9	Nut	*	4
10	Adapter	2182-010-00	4
11	Casing Seal	Incl. w/ Ref KIT	1
12 & 13	Shaft Seal Assembly - Viton & Silicon Carbide	1641-166-91	1
14	Shaft Sleeve	1483-149-00	1
15	Impeller Shim Set	1658-000-90	1
16	Impeller	3935-012-01	1
17	Fastener	*	2
18	Volute	2182-002-01	1
19	Flapper Valve	Incl. w/ Ref KIT	1
20	Casing	2112-001-02	1
21	1/2" NPT Pipe Plug	*	2
22	Fastener	*	4
23	Washer	*	12
24	Nut	*	4
KIT	O-Ring & Flapper Kit - Viton (includes Ref. Nos. 11 and 19)	3540-301-90	1

(*) Standard hardware item, available locally.

Order Online: www.PumpCatalog.com



AMT Pump Company
(herein "AMT")
400 Spring Street
Royersford, PA 19468
Phone: (610) 948-3800
Fax: (610) 948-5300
www.amtpump.com



General Information

SALES POLICY: AMT products are sold through our established Distributors. We do not sell direct to the consumer or organization not entitled to trade recognition. Therefore, possession of our catalogs and/or price list(s) does not infer an offer to sell.

MINIMUM ORDER: We appreciate your order, however, all orders are subject to a minimum \$35.00 net invoice charge (excluding freight). This applies to all pump and parts purchase orders.

PRICES: Prices are subject to change without notice. All orders accepted are subject to prices in effect at time of shipment.

PAYMENT TERMS: Terms, upon establishment of credit, are Net 30 days. Past due accounts may be subject to a service charge of 1.5% per month. Domestic or assignable letter of credit is required for all export trade.

PAST DUE ACCOUNTS: AMT reserves the right to withhold open account shipments on any past due account. Invoices are considered past due after thirty (30) days. In the interest of sound business, all orders are subject to approval of the Credit Department.

SHIPPING INSTRUCTIONS: All shipments will be made F.O.B. the factory. Where instructions for shipment do not appear on the order, the shipment will be made according to our best judgment. Full risk of loss (including transportation delays and losses) shall pass to the customer upon delivery of the products to the carrier at the F.O.B. point. When loss or delay occurs, primary responsibility for tracing rests with the customer. When there is LOSS or APPARENT VISIBLE DAMAGE to a shipment, when tendered for delivery, **DO NOT** give the carrier a clear receipt. Note such damage on the carrier's delivery receipt and **HAVE THE DRIVER SIGN THE RECEIPT.**

PRODUCT REVISIONS: AMT reserves the right to discontinue, change or improve its products or any portions thereof without being obligated to provide such a change or improvement for units sold and/or shipped prior to such a change or improvement.

LEAD TIME: Products designated "Quick Ship Product", also referred to as "QSP" will normally be shipped within 24 hours of receipt of a non-cancellable purchase order. Only limited quantities of "QSP" pumps are available.

STANDARD LEAD TIME: Lead time is two weeks for all non "QSP" product. AMT reserves the right to revise lead times as required due to availability of materials and all other causes beyond our control.

VIP SHIPMENT: Select AMT and IPT branded pumps are available for next day shipment for non-QSP (Quick Ship Products) items and subjected to a specific model surcharge per unit noted in the respective price book. Requires calling for availability, confirmation and a non-cancellable purchase order or credit card payment prior to shipment. The expedited shipping charges are an additional cost added separately from the VIP charges per item. AMT reserves the right to revise lead times as required due to availability of materials and all other causes beyond our control. QSP quantities are limited as determined by AMT.

ALL purchase orders must be submitted via hard copy sent to AMT customer service department by fax, EDI or e-mail.

RETURN GOODS POLICY: Goods shall not be returned without a return goods authorization number (RGA) issued by AMT customer service. The RGA number must be listed on the packing list. Only current model and part numbers with a valid date code may be returned (within one year from date of purchase). **A 20% restocking and packaging charge will apply to all returns. All shipping charges must be pre-paid. No exceptions.**

ORDER CHANGES BY CUSTOMER: Orders in process may not be changed except with written consent and may be subject to special charges.

12 Month Limited Warranty

EXTENT AND DURATION OF LIMITED WARRANTY

Coverage: AMT Pump Company (herein "AMT") or IPT Pumps by Gorman-Rupp (herein "IPT") or Gorman-Rupp Industries Division of The Gorman-Rupp Company, Patterson, or the Gorman-Rupp Company (herein referred to as "G-R Unit") each individually warrants that its products and parts shall be free from defects in material and workmanship for twelve (12) months from the date of purchase by the original end user when installation is made and maintenance is performed in accordance with G-R Unit's recommendations. Wear and tear resulting from use and items normally consumed in use are not covered.

EXCEPTIONS

(A) This Limited Warranty shall not apply to mechanical seals in AMT or IPT pumps and the following products and parts: engines, motors, trade accessories and all other products, components, parts and materials not manufactured by the G-R Units. These items may, however, be covered by the warranties of their respective manufacturers. (B) This warranty does not extend to or apply to any unit which has been repaired or altered at any place other than by a G-R Unit, or by persons not expressly approved by a G-R Unit to make repairs or alterations, nor to any unit the serial number, model number or identification of which has been removed, defaced or altered. (C) This warranty does not extend to any product manufactured by a G-R Unit, which has been subjected to mis-use, neglect, accident, improper installation, or use in violation of instructions furnished by a G-R Unit. (D) Pump Kits: This warranty does not extend to any product sold by a G-R Unit unassembled as a Pump Kit. Pump Kits are warranted against defects in material and workmanship for 60 days from the date of shipment from a G-R Unit. Any Pump Kit parts deemed defective by a G-R Unit will be replaced free of charge within 60 days of shipment. Pump Kits are not returnable for credit.

LIMITATIONS

THE G-R UNITS' SOLE AND EXCLUSIVE WARRANTY WITH RESPECT TO THEIR PRODUCTS AND PARTS IS THIS LIMITED WARRANTY. THIS LIMITED WARRANTY IS IN LIEU OF ALL OTHER EXPRESS AND/OR IMPLIED WARRANTIES, INCLUDING IMPLIED WARRANTIES OF MERCHANTABILITY AND FITNESS FOR PARTICULAR PURPOSE.

EXCLUSIVE REMEDY AND DAMAGES

The sole and exclusive remedy for breach of this Warranty by a G-R Unit and the entire extent of its liability for such breach or for damages arising from the use of the products and parts covered under this Limited Warranty, shall be as follows:

- Repair or Replacement:** If inspection shows that any G-R Unit product or part covered under this Limited Warranty is defective in materials or workmanship, the G-R Unit shall repair or replace the defective or non-conforming product or part without charge, whichever the G-R Unit chooses. You must have properly maintained and used the product or part claimed to be defective in accordance with the maintenance schedule or manual, which comes with the product. No allowance will be made for labor, installation, removal, transportation or other charges incurred by you in connection with such repair or replacement.
- To obtain the above remedy:
 - Immediately notify the G-R Unit upon discovery of the claimed defect in materials or workmanship and provide the serial number or date code of the product and/or part(s) or provide the G-R Unit with the invoice or bill of sale referencing the product by no later than the expiration date of the warranty period.
 - The G-R Unit will advise whether inspection will be necessary and how whether repair or replacement will be made. If inspection by the G-R Unit is necessary, the pump or defective part must be sent freight pre-paid to the G-R Unit. Return shipment will be F.O.B. the G-R Unit's plant.
 - Return Goods Authorization Requirement:** No product will be accepted for return or replacement without the prior written authorization of the G-R Unit. Upon such authorization, and in accordance with instructions from the G-R Unit, the product will be returned to the G-R Unit, shipping charges prepaid by the Buyer.
- Damages:** The G-R Unit's liability for damages for breach of this Limited Warranty shall not exceed the amount of the purchase price of the product or part(s) in respect to which Such damages are claimed. **IN NO EVENT SHALL THE G-R UNITS BE LIABLE FOR INCIDENTAL, CONSEQUENTIAL OR SPECIAL DAMAGES FOR BREACH OF THIS LIMITED WARRANTY.**

Some states do not allow the exclusion or limitation of incidental or consequential damages, so the above limitation or exclusion may not apply to you. This Limited Warranty gives you specific legal rights, and you may also have other rights, which vary from state to state.