

# **BALDOR® • RELIANCE**

## **Product Information Packet**

### **EM7086T-I**

**60//50HP, 1185//985RPM, 3PH, 60//50HZ, 404T**

Part Detail							
Revision:	D	Status:	PRD/A	Change #:		Proprietary:	No
Type:	AC	Prod. Type:	A40072M	Elec. Spec:	A40WG0491	CD Diagram:	416820-002
Enclosure:	TEFC	Mfg Plant:		Mech. Spec:		Layout:	617433-513
Frame:	404T	Mounting:	F1	Poles:	06	Created Date:	04-27-2015
Base:		Rotation:	R	Insulation:	F	Eff. Date:	09-30-2016
Leads:	3#4,6#6					Replaced By:	
Literature:		Elec. Diagram:					

Nameplate NP2496L	
MOBIL POLYREX EM	

Nameplate 000613006PC	
CLASS I GROUP	C D X
CLASS II GROUP	X X X
OPERATING TEMP CODE	T3C

Nameplate NP2293L			
CAT.NO.	EM7086T-I	SPEC NO.	A40-6593-0491
HP	60//50	PHASE	3
RPM	1185//985	DESIGN	B
VOLTS	230/460//190/380	TYPE	P
AMPS	135/67.3//136/68.2	AMB	40
DRIVE END BEARING	80BC03J30X	SF	1.15
OPP D.E. BEARING	80BC03J30X	DUTY	CONT
SER.NO.		INSUL.CLASS	F
		ENCL	TEFC
		CODE	G
		NEMA-NOM-EFFICIENCY	94.5
		SUITABLE FOR 55C AMB @ 1.0 SF	
	NEMA MG-1 PT 5, IP55	MOTOR WEIGHT	1375
		FRAME	404T

Parts List		
Part Number	Description	Quantity
SA312628	SA A40-6593-0491	1.000 EA
RA300067	RA A40-6593-0491	1.000 EA
421948032	LABEL, MYLAR	1.000 EA
LB1073	ALUM XP CAUTION LABEL	1.000 EA
NP2496L	MOTOR LUBE NAMEPLATE	1.000 EA
000692000VD	LABEL WARNING	1.000 EA
000613006PC	N/P U/L (REL QTY 500)	1.000 EA
NP2293L	BALDOR RELIANCE INDUST. MTR,SS,CSA-C US,	1.000 EA
HW4506A02	BREATHER/DRAIN-EXP PROOF-.125-27 NPTF AI	2.000 EA
609158001E	SLGR - 400	1.000 EA
603284001Y	SLGR - 400	1.000 EA
089416503A	G400 STD BRKT MACHINING 6316 BE OR FE	1.000 EA
415072001B	CLAMP	1.000 EA
083198101A	G400 STD FAN COVER MACHINING	1.000 EA
034180012DA	KEY 1X4X1/4X1-1/2 L	1.000 EA
078550001H	FAN KB 120/60 360	1.000 EA
004824015A	GREASE POLYREX EM	0.880 LB
032018008CK	HHCS 3/8-16X1L PLATED	4.000 EA
032018028CK	HHCS 3/8-16X3-1/2 PLTD.	3.000 EA
415045002B	SLGR	1.000 EA
410700000DA	WAVY SPRING WASHER	1.000 EA
034017022AB	LCKW X 7/8 - ZINC PL. STEEL	4.000 EA
034017014AB	LCKW 3/8 STD. PLATED	4.000 EA
034000014AB	WSH ID.406 OD.812 TH.065	4.000 EA

Parts List (continued)		
Part Number	Description	Quantity
032130024GB	SHSCS 7/8-9NC X 3" LONG PLATED	4.000 EA
034017014AB	LCKW 3/8 STD. PLATED	3.000 EA
034530052AB	P/NIP 1/8X6-1/2 GALV.	1.000 EA
415096002A	CPLG 1/8 HEX TYPE	1.000 EA
035000001A	ALFTG 1/8" 1610-BL	1.000 EA
034530056BB	P/NIP 1/4X7 SCHED 40	1.000 EA
034631002AB	BUSH 1/4 TO 1/8 PLTD.	1.000 EA
035000001G	GREASE RELIEF FITTING, ALEMITE 317400	1.000 EA
035000001A	ALFTG 1/8" 1610-BL	1.000 EA
415096002A	CPLG 1/8 HEX TYPE	1.000 EA
034530040AB	P/NIP 1/8X5 GALV.	1.000 EA
034530040BB	P/NIP 1/4X5	1.000 EA
034631002AB	BUSH 1/4 TO 1/8 PLTD.	1.000 EA
035000001G	GREASE RELIEF FITTING, ALEMITE 317400	1.000 EA
089416503A	G400 STD BRKT MACHINING 6316 BE OR FE	1.000 EA
032018028CK	HHCS 3/8-16X3-1/2 PLTD.	3.000 EA
415045002B	SLGR	1.000 EA
034017022AB	LCKW X 7/8 - ZINC PL. STEEL	4.000 EA
034017014AB	LCKW 3/8 STD. PLATED	3.000 EA
032130024GB	SHSCS 7/8-9NC X 3" LONG PLATED	4.000 EA
16CB1001A01	CONDUIT BOX MACH. GROUP C MTRS	1.000 EA
16CB1501A01	CONDUIT BOX LID MACH.GRP C MTRS 16CB1501	1.000 EA
032130014CB	SHSCS 3/8-16X1-3/4 PLTD.	4.000 EA
034017014AB	LCKW 3/8 STD. PLATED	4.000 EA

Product Information Packet: EM7086T-I - 60//50HP,1185//985RPM,3PH,60//50HZ,404T

032130012EB	SHHCS 5/8-11X1-1/2 PLTD.	8.000 EA
034017018AB	LCKW 5/8"	8.000 EA
415000103D	T/LUG #4AWG-1/0AWG W/HOLE FOR .250 BOLT	1.000 EA
406099000A	PLUG - FAN COVER 320-440	1.000 EA
032018008DK	HHCS 1/2-13X1 PLATED	1.000 EA
034036012AB	LCKW EXTERNAL TOOTH 1/4"	1.000 EA
MG1025G05	WILKOFAS, 789.227, MED. GRAY CHAR. MET.	0.750 GA
033775004EA	DRSCR #6-1/4 304 S.S.	8.000 EA
034180044JA	KEY 3/4X3/4X5-1/2 L	1.000 EA
604797045	STD. 400 FRAME SKID	1.000 EA
032510024D	CARRIAGE BOLT - 444	2.000 EA
034001014AB	FLAT WASHER 3/8"PLATED	2.000 EA
034001016AB	WSHR .562ID 1.375OD .109	2.000 EA
033300014AC	HEX NUT, SHIPPING - 400	2.000 EA
604797003C	SHIPPING BAG	1.000 EA

REL. S.O.	FRAME	HP	TYPE	PHASE/HERTZ	RPM	VOLTS
	404T	60	P	3/60	1185	230/460
AMPS	DUTY	AMB °C/ INSUL.	S.F.	NEMA DESIGN	CODE LETTER	ENCL.
135/67.3	CONT	40/F	1.15	B	G	XPFC
E/S	ROTOR	TEST S.O.	TEST DATE	STATOR RES. @25 °C (OHMS (BETWEEN LINES))		
495024	418142073DE	---	---	.0295/.118		

PERFORMANCE						
LOAD	HP	AMPERES	RPM	POWER FACTOR %	EFFICIENCY %	
NO LOAD	0	19.7	1200	5.46	0	
1/4	15.0	25.5	1196	59.9	92.1	
2/4	30.0	37.4	1193	79.3	94.6	
3/4	45.0	51.6	1189	86.0	94.9	
4/4	60.0	67.3	1185	88.3	94.5	
5/4	75.0	84.2	1181	88.9	93.9	

SPEED TORQUE						
	RPM	TORQUE % FULL LOAD	TORQUE LB.-FT.	AMPERES		
LOCKED ROTOR	0	167	444	434		
PULL UP	180	141	376	415		
BREAKDOWN	1119	253	673	252		
FULL LOAD	1185	100	266	67.3		

AMPERES SHOWN FOR 460. VOLT CONNECTION. IF OTHER VOLTAGE CONNECTIONS ARE AVAILABLE, THE AMPERES WILL VARY INVERSELY WITH THE RATED VOLTAGE

REMARKS: TYPICAL DATA  
NEMA PREMIUM - 94.5 PCT NOMINAL EFFICIENCY

<b>BALDOR</b>	DR. BY	W. L. SMITH	<b>A-C MOTOR</b>
	CK. BY	J. J. HARRISON	
	APP. BY	W. L. SMITH	
	DATE	08/25/10	
<b>PERFORMANCE DATA</b>		<b>A40WG0491-R001</b>	<b>ISSUE DATE 01/07/11</b>

REL. S.O. \_\_\_\_\_ RPM 1185 S.F. 1.15 ROTOR 418142073DE  
 FRAME 404T VOLTS 230/460 NEMA DESIGN B TEST S.O. TYPICAL DATA  
 HP 60 AMPS 135/67.3 CODE LETTER G TEST DATE ---  
 TYPE P DUTY CONT ENCLOSURE XPFC STATOR RES. @ 25 °C .0295/.118  
 PHASE/HERTZ 3/60 AMB °C/INSUL 40/F E/S 495024 OHMS (BETWEEN LINES)

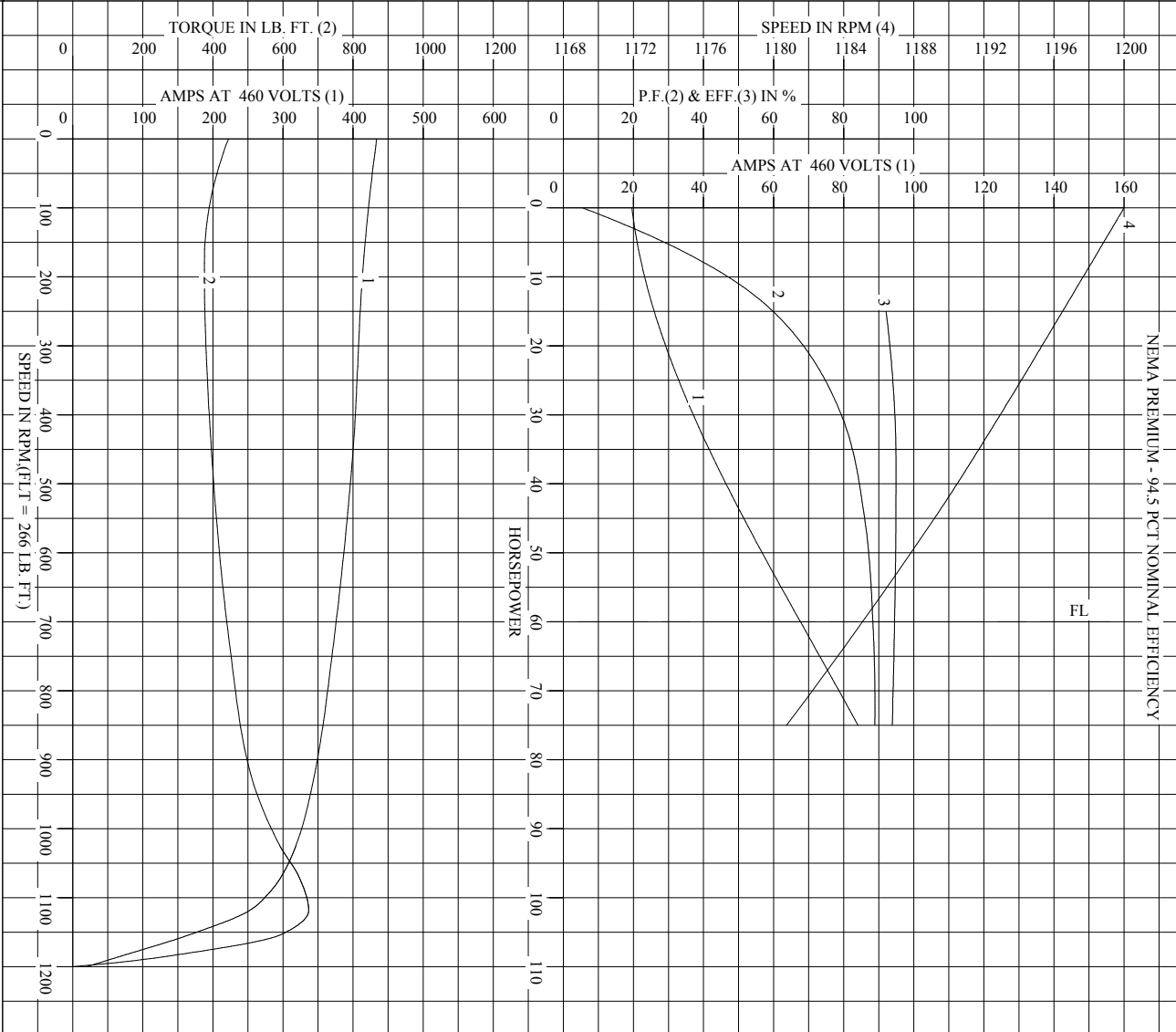

AMPERES SHOWN FOR 460 VOLT CONNECTION, IF OTHER VOLTAGE CONNECTIONS ARE AVAILABLE, THE AMPERES WILL VARY INVERSELY WITH THE RATED VOLTAGE.

**BALDOR**

DR. BY W.L. SMITH  
 CK. BY J.H. HARRISON  
 APP. BY W.L. SMITH  
 DATE 08/25/10

**A-C MOTOR PERFORMANCE CURVES** A40W/G0491-R001  
 ISSUE DATE 01/07/11

Printed on 1/7/11 11:38 @ psecs-motorengr

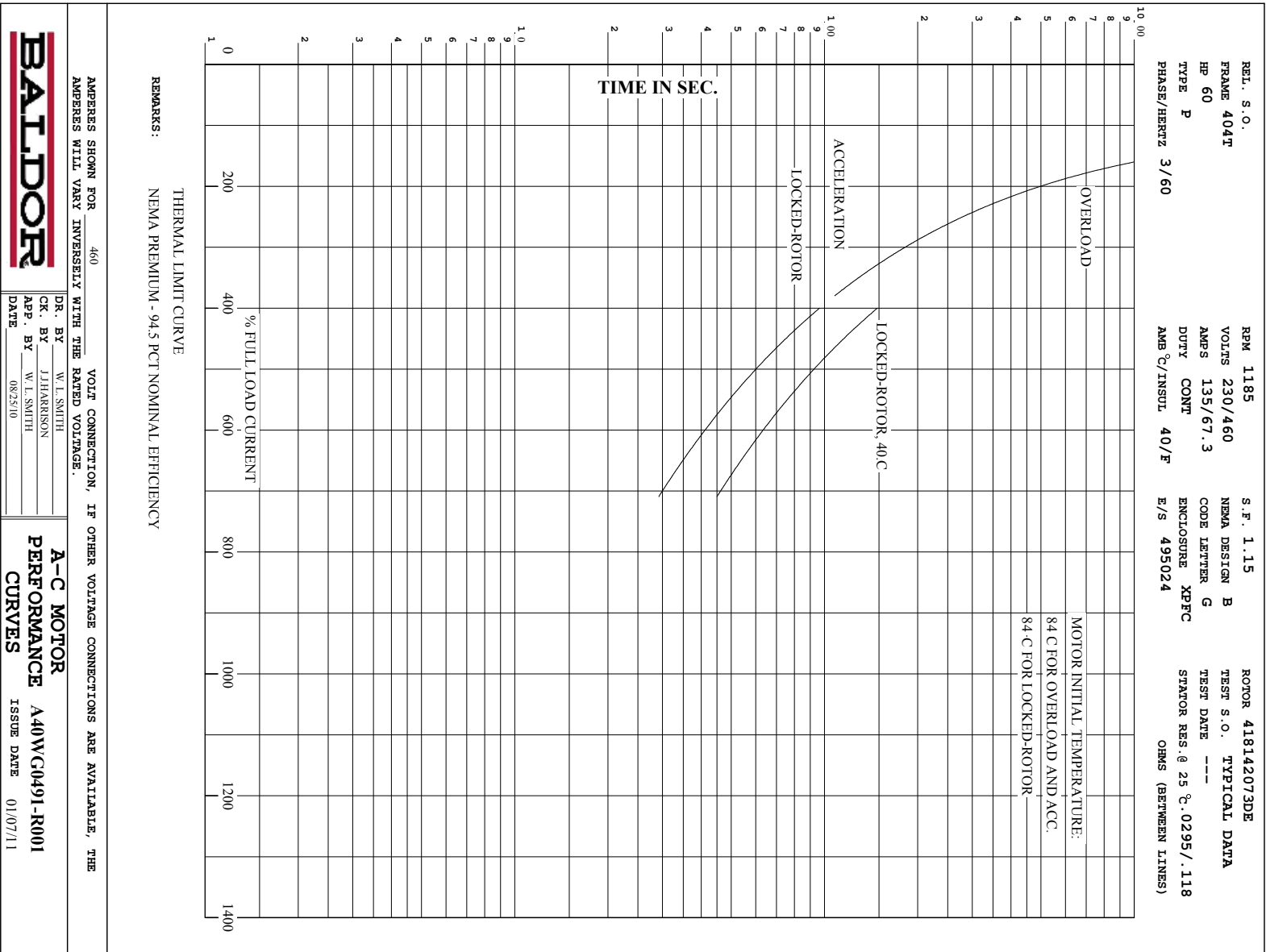

AMPERES SHOWN FOR 460 VOLT CONNECTION, IF OTHER VOLTAGE CONNECTIONS ARE AVAILABLE, THE AMPERES WILL VARY INVERSELY WITH THE RATED VOLTAGE.



DR. BY W. L. SMITH  
 CK. BY J. HARRISON  
 App. BY W. L. SMITH  
 DATE 08/25/10

**A-C MOTOR**  
**PERFORMANCE** A40WG0491-R001  
**CURVES** ISSUE DATE 01/07/11

## DUTY MASTER ALTERNATING CURRENT MOTORS

SQUIRREL-CAGE INDUCTION

ENCLOSURE: X/P, UNDERWRITERS LISTED

FRAME G405T

COOLING: FAN COOLED

MOUNTING: FOOT

INCLUDES 404T FRAME MOUNTING HOLES

XT/ECP SEVERE DUTY ENCLOSURE

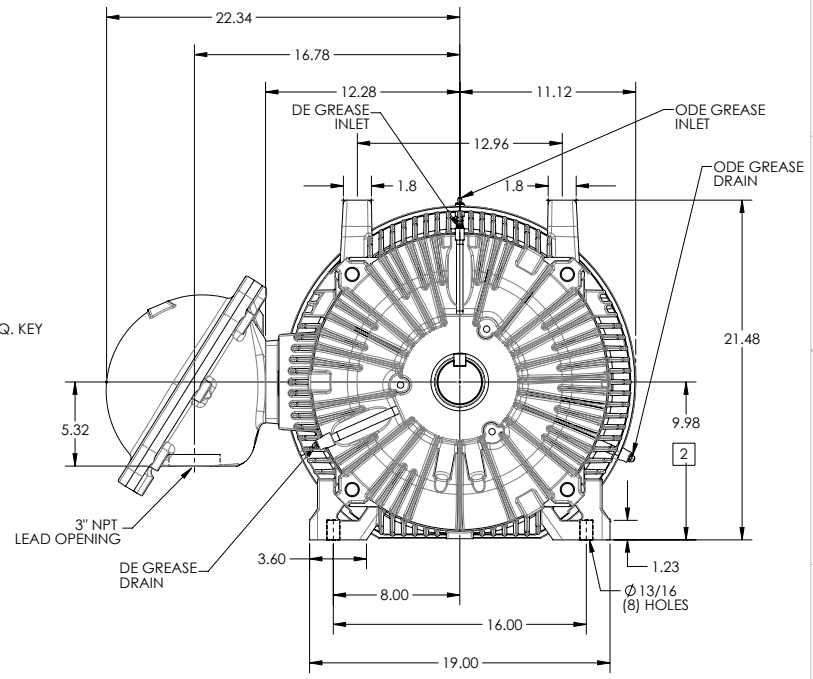
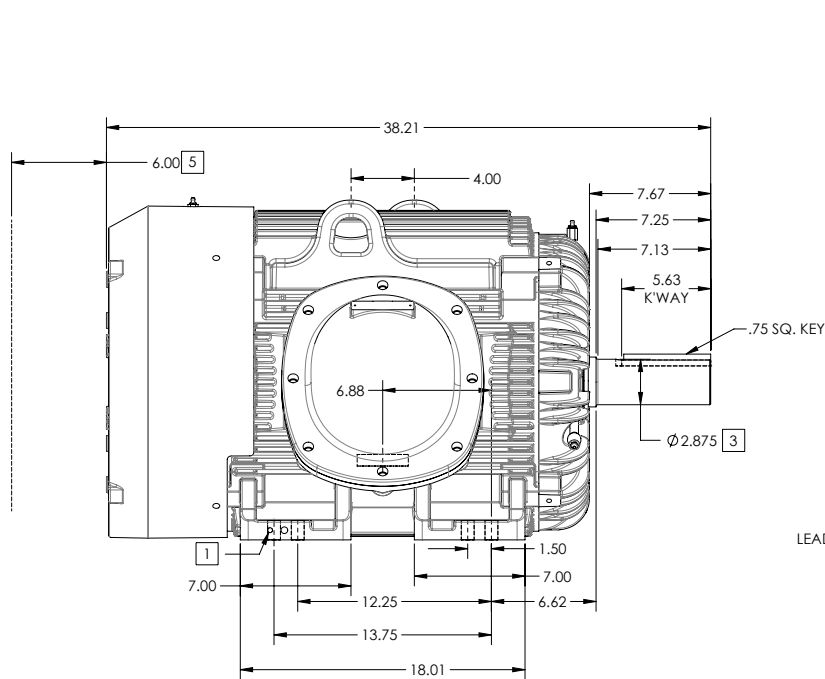

1. GROUND HOLES QTY 1 1/2-13 TAP; QTY 1 3/8-16 TAP
2. VARIES +.00,-.06
3. VARIES +.00,-.001
4. MOTOR WEIGHTS MAY VARY BY 15% DEPENDING ON RATING.
5. OBSTRUCTION MUST NOT ENCROACH ON AIR INLET

**4** WEIGHT (LBS): 1400

CONDUIT BOX LOCATED ON OPPOSITE SIDE WHEN F-2.  
IF MOUNTING CLEARANCE DETAILS ARE REQUIRED, CONSULT FACTORY.  
MAXIMUM PERMISSIBLE SHAFT RUNOUT WHEN MEASURED AT END OF  
STANDARD SHAFT EXTENSION IS .003\"/>

DIMENSIONS ARE IN INCHES; SEE SHEET 2 FOR DIMENSIONS IN MILLIMETERS

CUSTOMER IS RESPONSIBLE FOR DETERMINING THAT MOTOR PERFORMANCE IS SUITABLE IN THE APPLICATION.

SHEET NUMBER  
**1 OF 2**

617433-513

REV. DESC: NEW	VERSION: 00	REVISED: 08-51-52 11/20/2015	TDR: 00000926001
MODEL NO. 617433-513	BY: RAGTBM	Material:	REF:

**BALDOR**

G405T-404T XP TEFC FOOT, DRILL, RIG DUTY, I6CB1001A01 BOX

617433-513

## DUTY MASTER ALTERNATING CURRENT MOTORS

SQUIRREL-CAGE INDUCTION

ENCLOSURE: X/P, UNDERWRITERS LISTED

FRAME G405T

COOLING: FAN COOLED

MOUNTING: FOOT

INCLUDES 404T FRAME MOUNTING HOLES

XT/ECP SEVERE DUTY ENCLOSURE

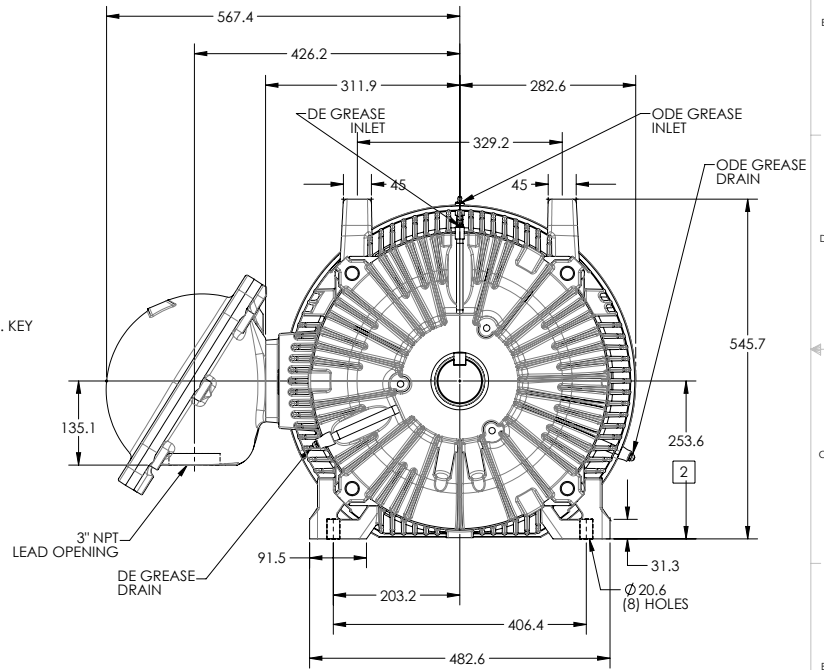
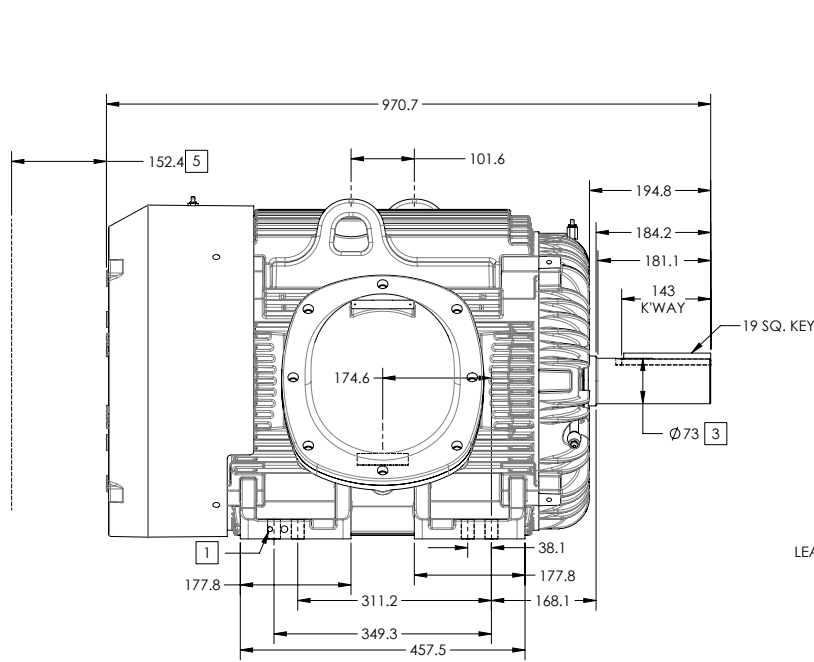

1. GROUND HOLES QTY 1 1/2-13 TAP; QTY 1 3/8-16 TAP
2. VARIES +.00,-1.5MM
3. VARIES +.00,-.025MM
4. MOTOR WEIGHTS MAY VARY BY 15% DEPENDING ON RATING.
5. OBSTRUCTION MUST NOT ENCROACH ON AIR INLET

**6** MASS (KGS): 635

CONDUIT BOX LOCATED ON OPPOSITE SIDE WHEN F-2.  
IF MOUNTING CLEARANCE DETAILS ARE REQUIRED, CONSULT FACTORY.  
MAXIMUM PERMISSIBLE SHAFT RUNOUT WHEN MEASURED AT END OF  
STANDARD SHAFT EXTENSION IS .076MM T.I.R. TO 130MM DIA.

DIMENSIONS ARE IN MILLIMETERS; SEE SHEET 1 FOR DIMENSIONS IN INCHES

CUSTOMER IS RESPONSIBLE FOR DETERMINING THAT MOTOR PERFORMANCE IS SUITABLE IN THE APPLICATION.

SHEET NUMBER  
**2 OF 2**

E15-EEZL19



REV. DESC: NEW	VERSION: 00	REVISED: 08-51-52 11/20/2015	TDR: 00000926001
MODEL NO. 617433-513	BY: RAGTBM	Material:	REF:

**BALDOR**

G405T-404T XP TEFC FOOT, DRILL, RIG DUTY, I6CB1001A01 BOX

## CONNECTION DIAGRAM ACCESSORIES

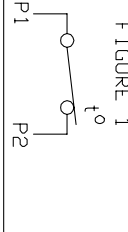
MOTOR WINDING THERMOSTATS	
CONTACTS _____ @ _____ °C	
FIGURE NUMBER _____	
CONTACT RATING	
VOLTS	CONTINUOUS AMPERES
110-120	3.0
220-240	1.5
440-480	0.75
550-600	0.60
	INRUSH AMPERES
	30
	15
	7.5
	6.0

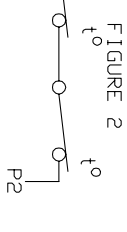
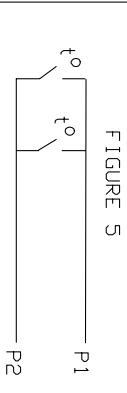
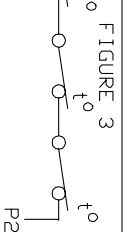
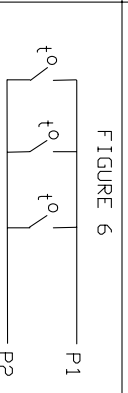
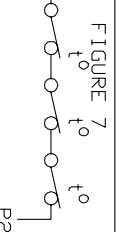
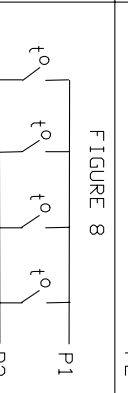
NORMALLY CLOSED	THERMOSTATS	NORMALLY OPEN
 <p>FIGURE 1</p>		 <p>FIGURE 4</p>
 <p>FIGURE 2</p>		 <p>FIGURE 5</p>
 <p>FIGURE 3</p>		 <p>FIGURE 6</p>
 <p>FIGURE 7</p>		 <p>FIGURE 8</p>

CUSTOMER \_\_\_\_\_ CUSTOMER ORDER NO. \_\_\_\_\_ S.D. NO. \_\_\_\_\_

418174-006

418174-006

REV. DESC: LOADED TO BUS		TDR: 000000570390
REV. LTR: A	VERSION: 01	BY: RAGDRF
FILE: \RAG\00013\849	REVISED: 10:16:21 12/07/2010	
MTL: -		

**BALDOR**

A-C MOTOR CONNECTION ACCESSORIES

SH 1 of 1



Marketing maintained PDF of MN408:

<http://www.baldor.com/support/Literature/Load.ashx/MN408?ManNumber=MN408>

Marketing maintained PDF of MN416:

<http://www.baldor.com/support/Literature/Load.ashx/MN416?ManNumber=MN416>