

BALDOR® • RELIANCE

Product Information Packet

EMM3714

7.5KW,1770RPM,3PH,60HZ,D132M,3752M,TEFC

Part Detail							
Revision:	J	Status:	PRD/A	Change #:		Proprietary:	No
Type:	AC	Prod. Type:	3752M	Elec. Spec:	37WGS518	CD Diagram:	CD0005
Enclosure:	TEFC	Mfg Plant:		Mech. Spec:	37E617	Layout:	37LYE617
Frame:	D132M	Mounting:	B3	Poles:	04	Created Date:	04-26-2010
Base:	RG	Rotation:	R	Insulation:	F	Eff. Date:	06-02-2016
Leads:	9#14					Replaced By:	
Literature:		Elec. Diagram:					

Nameplate NP1159L					
CAT.NO.	EMM3714				
SPEC.	37E617S518G1				
IEC FRAME	D132M	KW	7.5KW		
VOLTS	230/460				
AMP	24/12				
RPM	1770	ENCL	TEFC		
HZ	60	PH	3	CL	F
SER.F.	1.15	DES	A	CODE	K
NEMA-NOM-EFF	91.7	I.P.	54		
RATING	40C AMB-CONT				
CC	010A	USABLE AT 208V	25.4		
DE	6208	ODE	6206		
SER. #					
	10 HP				

Parts List		
Part Number	Description	Quantity
SA194070	SA 37E617S518G1	1.000 EA
RA181662	RA 37E617S518G1	1.000 EA
37FN3002C01	EXFN, PLASTIC, 6.00 OD, 1.155 ID	1.000 EA
HW3200A01	3/8-16X3/4 I-BLT WELDED F/S	1.000 EA
37CB3004	37 CB CASTING W/1.09 LEAD HOLE @ 6:00	1.000 EA
37GS1000	GASKET, CONDUIT BOX STD., .06 THICK LEXI	1.000 EA
51XW2520A12	.25-20 X .75, TAPTITE II, HEX WSHR SLTD	2.000 EA
11XW1032G06	10-32 X .38, TAPTITE II, HEX WSHR SLTD U	1.000 EA
37EP3101A01	FR ENDPLATE, FOR ROUTING PURPOSES	1.000 EA
HW4500A01	1641B(ALEMITE)400 UNIV, GREASE FITT	1.000 EA
HW5100A06	W2420-025 WVY WSHR (WB)	1.000 EA
37EP3100A11	PU ENDPLATE, MACH	1.000 EA
HW4500A01	1641B(ALEMITE)400 UNIV, GREASE FITT	1.000 EA
XY3118A12	5/16-18 HEX NUT DIRECTIONAL SERRATION	4.000 EA
51XB1214A20	12-14X1.25 HXWSSLD SERTYB	1.000 EA
07FH4007SP	PRIMED	1.000 EA
51XW1032A06	10-32 X .38, TAPTITE II, HEX WSHR SLTD S	3.000 EA
37CB4516	LIPPED LID FOR 37 FRAME NEC KOBX	1.000 EA
37GS1008	37 GS FOR CB LID - LEXIDE	1.000 EA
51XW0832A07	8-32 X .44, TAPTITE II, HEX WSHR SLTD SE	4.000 EA
HA1005A12	SLINGER, OD 2.50, ID 1.433, 208 BRG	1.000 EA
HW2505B19	KEY, 8 X 10 MM X 2.125 IN	1.000 EA
85XU0407S04	4X1/4 U DRIVE PIN STAINLESS	2.000 EA
LB1115N	LABEL,LIFTING DEVICE (ON ROLLS)	1.000 EA

Parts List (continued)		
Part Number	Description	Quantity
MJ1000A02	GREASE, POLYREX EM EXXON (USe 4824-15A)	0.050 LB
MG1000Y03	MUNSELL 2.53Y 6.70/ 4.60, GLOSS 20,	0.028 GA
HA3104A25	THRUBOLT .31-18 X 14.75	4.000 EA
LC0005E01	CONN.DIA./WARNING LABEL (LC0005/LB1119N)	1.000 EA
NP1159L	SS SUPER-E IEC UL CSA CC	1.000 EA
37PA1039	PALLET PACK GRP, PRINT PK1026A06	1.000 EA
MN416A01	TAG-INSTAL-MAINT no wire (1000/bx) 11/14	1.000 EA

AC Induction Motor Performance Data

Record # 57408 - Typical performance - not guaranteed values

Winding: 37WGS518-R079	Type: 3752M	Enclosure: TEFC
-------------------------------	--------------------	------------------------

Nameplate Data				460 V, 60 Hz: High Voltage Connection	
Rated Output (KW)	7.5			Full Load Torque	30 LB-FT
Volts	230/460			Start Configuration	direct on line
Full Load Amps	24/12			Breakdown Torque	101 LB-FT
R.P.M.	1770			Pull-up Torque	45.1 LB-FT
Hz	60	Phase	3	Locked-rotor Torque	61.8 LB-FT
NEMA Design Code	A	KVA Code	K	Starting Current	103 A
Service Factor (S.F.)	1.15			No-load Current	5.36 A
NEMA Nom. Eff.	91.7	Power Factor	85	Line-line Res. @ 25°C	0.912 Ω
Rating - Duty	40C AMB-CONT			Temp. Rise @ Rated Load	68°C
S.F. Amps				Temp. Rise @ S.F. Load	84°C
				Locked-rotor Power Factor	35.2
				Rotor inertia	1.28 LB-FT ²

Load Characteristics 460 V, 60 Hz, 7.5 KW

% of Rated Load	25	50	75	100	125	150	S.F.
Power Factor	44	66	77	81	84	85	83
Efficiency	89.1	92.1	92.6	92.2	91.4	90.3	91.7
Speed	1791	1783	1775	1766	1756	1745	1760
Line amperes	6.08	7.74	10	12.6	15.4	18.4	14.3

Performance Graph at 460V, 60Hz, 7.5KW Typical performance - Not guaranteed values

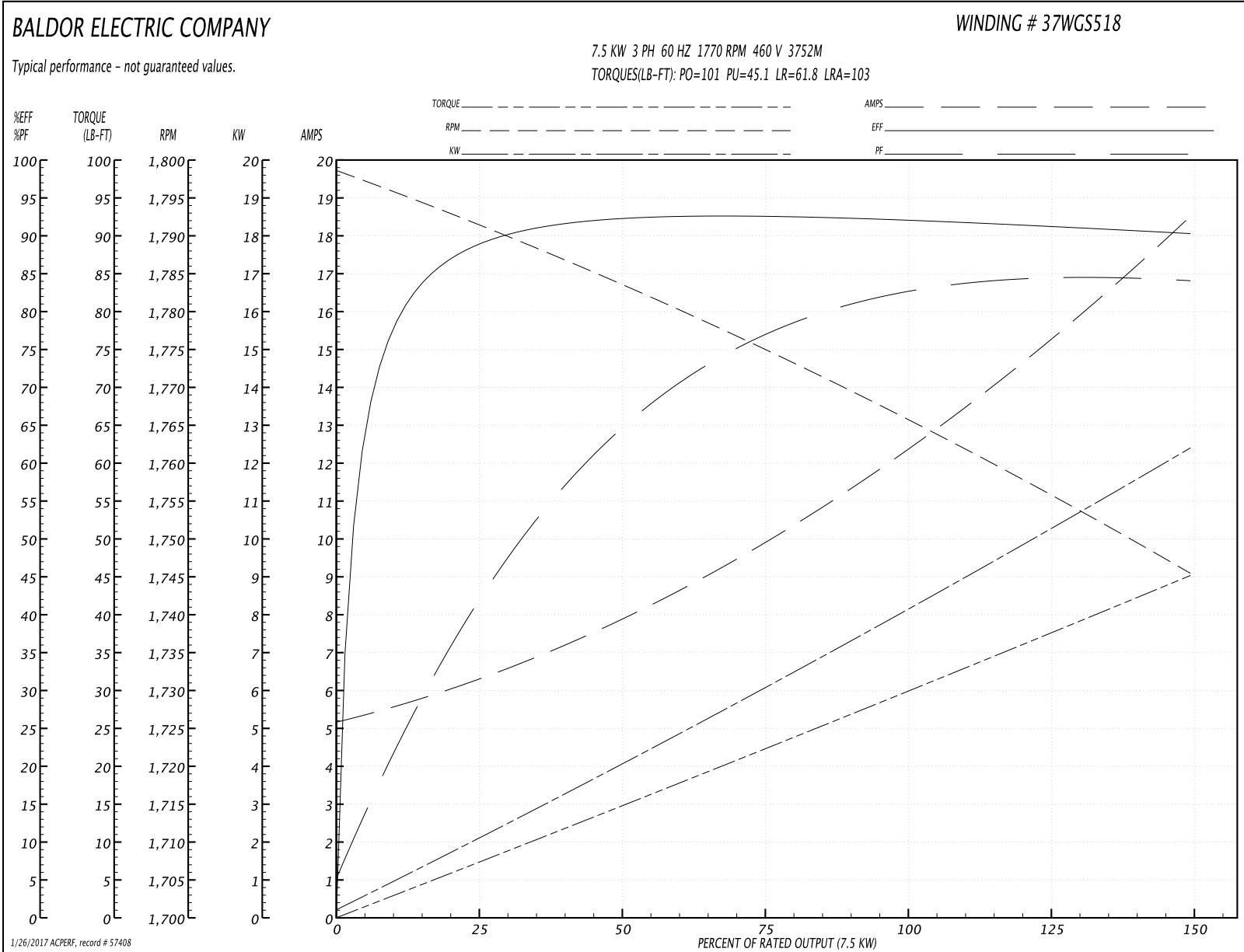

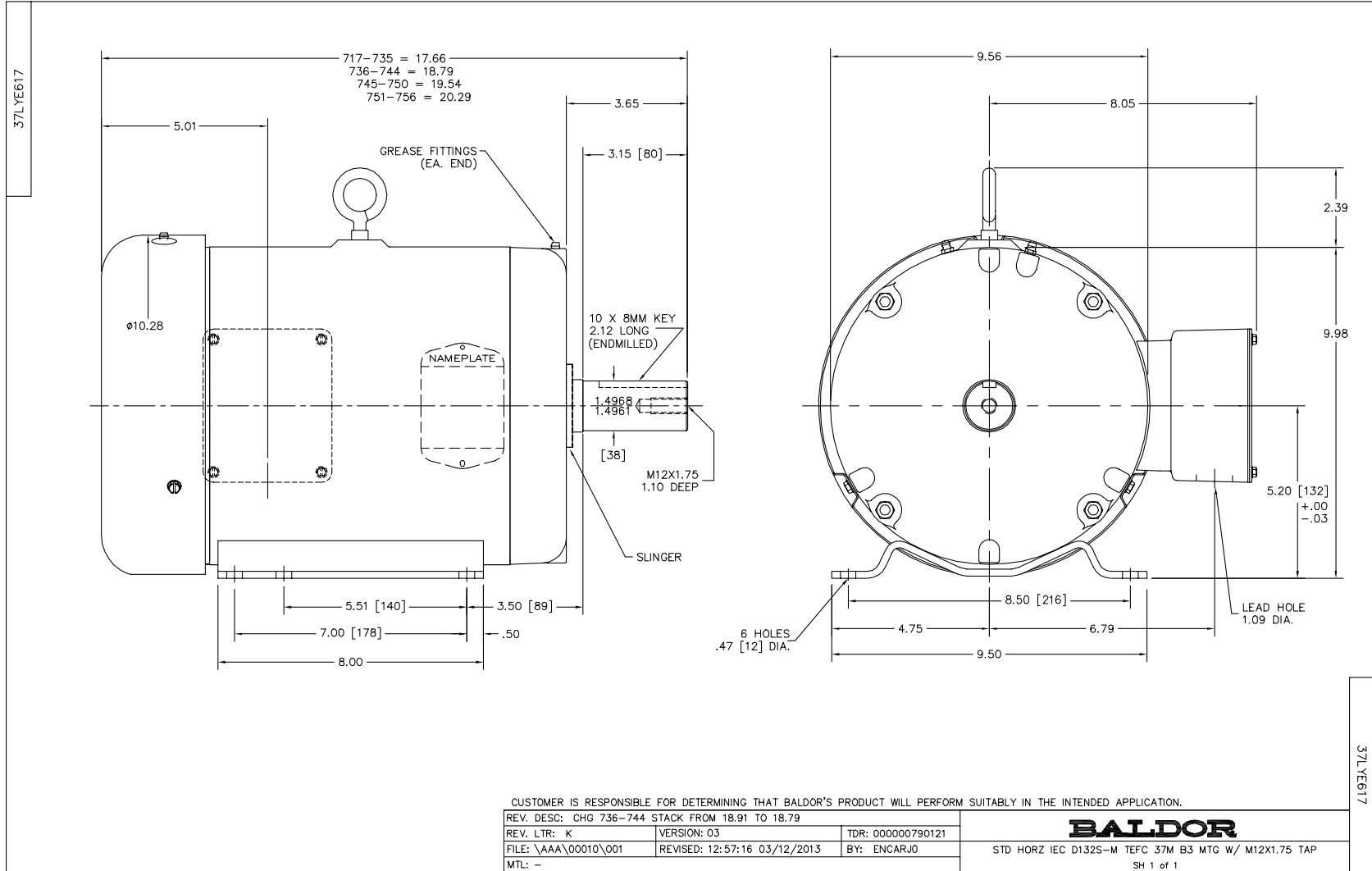

CD0005



LOW VOLTAGE
(2Y)



LINE

HIGH VOLTAGE
(1Y)



LINE

NOTES:

1. INTERCHANGE ANY TWO LINE LEADS TO REVERSE ROTATION.
2. OPTIONAL THERMOSTATS ARE PROVIDED WHEN SPECIFIED.
3. ACTUAL NUMBER OF INTERNAL PARALLEL CIRCUITS MAY BE A MULTIPLE OF THOSE SHOWN ABOVE.
4. LEAD COLORS ARE OPTIONAL. LEADS MUST ALWAYS BE NUMBERED AS SHOWN.

REV. DESC: REVISE TO SHOW OPTIONAL COLORS			
REV. LTR: E	BY: JLP	REVISED: 01/19/99 10:15	TDR: 0171435
900000		FILE: AAA00005140	MDL: -
		MTL: -	

BALDOR ELECTRIC Co.

3PH, DV, 9 LEADS

CD0005