

BALDOR® • ***RELIANCE***

Product Information Packet

ZDWNM22938T

10HP,1765RPM,3PH,60HZ,254TC,3956M,TENV

Part Detail							
Revision:	X	Status:	PRD/A	Change #:		Proprietary:	No
Type:	AC	Prod. Type:	3956M	Elec. Spec:	39WGW632	CD Diagram:	CD0005
Enclosure:	TENV	Mfg Plant:		Mech. Spec:	39S001	Layout:	39LYS001
Frame:	254TC	Mounting:	F1	Poles:	04	Created Date:	
Base:	RG	Rotation:	R	Insulation:	H	Eff. Date:	06-15-2016
Leads:	9#12					Replaced By:	
Literature:		Elec. Diagram:					

Nameplate NP1167L	
CAT NO	ZDWNM22938T
SPEC.	39S001W632Z1
FRAME	254TC HP 10 TE
VOLTS	230/460
MAG CUR	8.8/4.4 FLA 24/12
RPM	1765 RPM MAX 5000
HZ	60 PH 3 CLASS H
SER.F.	1.00 DES B SL HZ 1.22
NEMA-NOM-EFF	91.7 WK2 2.44
BLWR V	PH HZ A
RATING	40C AMB-CONT
DE BRG	6309 ODE BRG 6208
CC	010A SN

Parts List		
Part Number	Description	Quantity
SA084783	SA 39S001W632Z1	1.000 EA
RA077942	RA 39S001W632Z1	1.000 EA
HA6016WP	ADAPTER, CONDUIT BOX, W/WHITE EPOXY, PRIM	1.000 EA
09GS1006	GASKET, CONDUIT BOX, NEOP-1/16 THICK-BLA	1.000 EA
09CB3002A01WP	CB MACH - 1.25 N.P.T. LEAD HOLE W/WHITE	1.000 EA
51XW2520A12	.25-20 X .75, TAPTITE II, HEX WSHR SLTD	2.000 EA
HW1001A25	LOCKWASHER 1/4, ZINC PLT .493 OD, .255 I	2.000 EA
WD1000B17	T&B CX35TN TERMINAL	1.000 EA
11XW1032G06	10-32 X .38, TAPTITE II, HEX WSHR SLTD U	1.000 EA
39EP1100A25WP	FREP W/THRU SH ENC DESIGN & SEAL W/WHITE	1.000 EA
HW4600A31	SEAL,NATIONAL #453065 SINGLE LIP DOUBLE	1.000 EA
HW5100A08	W3118-035 WVY WSHR (WB)	1.000 EA
10XN2520S28	1/4-20X 1 3/4 HEX HD SS X	4.000 EA
39EP1500A04WP	PU ENDPLATE, MACH. W/WHITE EPOXY, PRIMED	1.000 EA
HW4600B53	SEAL 1.688 X 2.275 X 0.312 SINGLE LIP DB	1.000 EA
HW4600B44	V-RING SLINGER 1.500 X 1.810 X .28 VITON	1.000 EA
HA3154S02	THRUBOLT STUD 3/8-16 X 15.875 SS	4.000 EA
XY3816S12	3/8-16 HEX FINISHED NUT SS	8.000 EA
HA6881	BEI HS35 THRU SHAFT ENCODER PROTECTIVE C	1.000 EA
10XN3816S12	3/8-16 X 3/4 HEX HD CAP SCREW, STAINLE	3.000 EA
HW1001S38	WASHER, 3/8 SPLT LK, STAINLESS STEEL	3.000 EA
09CB3501WP	CB LID FOR 09CB3001 & 09CB3002 W/WHITE P	1.000 EA
12GS1002	GASKET, CONDUIT BOX LID, NEOP	1.000 EA
19XT2520S12	1/4-20X3/4 HWH NO SLOT TY.23 18-8 S.S.	2.000 EA

Parts List (continued)		
Part Number	Description	Quantity
HW1001S25	WASHER, 1/4 SPLT LK, STAINLESS STEEL	2.000 EA
HW2502G25	#303 SS,SQ KEY 3/8 X 2.880	1.000 EA
MJ5001A27	32220KN GRAY SEALER *MIN BUY 4 QTS=1GAL	0.016 QT
MJ5002A01	SILICON RUBBER SEALANT, 732CL 10.3 OZ TU	0.025 EA
LB1115N	LABEL,LIFTING DEVICE (ON ROLLS)	1.000 EA
HA5027A01	HA4066A01 T-DRAIN X2 BAGGED	1.000 EA
09GS1017	GASKET, CONDUIT BOX, .125 THICK BLACK NE	1.000 EA
HW4032A01	BLACK DRAIN PLUG FOR WASH DOWN MOTORS	3.000 EA
MJ1000A02	GREASE, POLYREX EM EXXON (USe 4824-15A)	0.030 LB
HW4032A01	BLACK DRAIN PLUG FOR WASH DOWN MOTORS	3.000 EA
OE5001A87	TENV W/OEHS35A15 W/BLIND SHAFT,TETHER, A	1.000 EA
MG1025W01	WILKOFASST, 781.01, SIGNAL WHITE #9003	0.050 GA
85XU0407S04	4X1/4 U DRIVE PIN STAINLESS	2.000 EA
LB1164	LABEL,WARNING AND DRAIN	1.000 EA
LC0005	CONN.DIA.,TY M,9-LD,DUAL VOLT,REVERSING	1.000 EA
NP1167L	SS VEC UL CSA CC	1.000 EA
40PA1000	PACKAGING GROUP	1.000 EA

AC Induction Motor Performance Data



AC Induction Motor Performance Data
 Record # 12831
 Typical performance - not guaranteed values

Winding: 39WGW632	Type: 3956M	Enclosure: TENV
--------------------------	--------------------	------------------------

Nameplate Data			General Characteristics at 460 V, 60 Hz: High Volt Connection		
Rated Output (HP)	10		Full Load Torque	30 LB-FT	
Volts	230/460		Start Configuration	DOL	
Full Load Amps	24/12		Break Down Torque	114 LB-FT	
R.P.M.	1765		Pull-Up Torque	41.5 LB-FT	
Hz	60	Phase	3	Locked-rotor Torque	58 LB-FT
NEMA Design Code	B	KVA Code	H	Starting Current	87 Amps
Service Factor	1		No-load Current	4.4 Amps	
NEMA Nom. Eff.	91.7	P.F.	85	Line-line Res. @ 25°C.	0.744 Ohms
Rating - Duty	40C AMB-CONT		Temp. Rise @ Rated Load	89°C	
S.F. Amps			Temp. Rise @ S.F. Load		

Load Characteristics at 460 Volts, 60 Hz, 10 HP

% of Rated Load	25	50	75	100	125	150	S.F.
Power Factor	52	72	81	85	86	87	
Efficiency	87.7	91.7	92.4	92	91.2	90.1	
Speed	1791	1783	1774	1764	1753	1741	
Line Amperes	5.3	7.2	9.5	12	14.9	17.9	

Baldor Electric Company Fort Smith, Arkansas



Catalog	ZDWNM22938T	NP VOLTS	230/460	ENCLOSURE	TENV	WYE CONN EQ CKT OHMS PER PHASE (BASE RATING, 20C)
FRAME	254TC	NP AMPS	24/12	Base Volts	460	R1 0.355
HP	10 HP	DUTY	Cont	Base AMPS	12	R2 0.319
BASE SPEED	1800	MAX SAFE RPM	5000	Slip Hz	1.20	XM1
PHASE/HZ	3/60	AMB ⁰ /C/INSUL	40/H	WK ² (lb-ft ²)	2.45	XM2 56.060

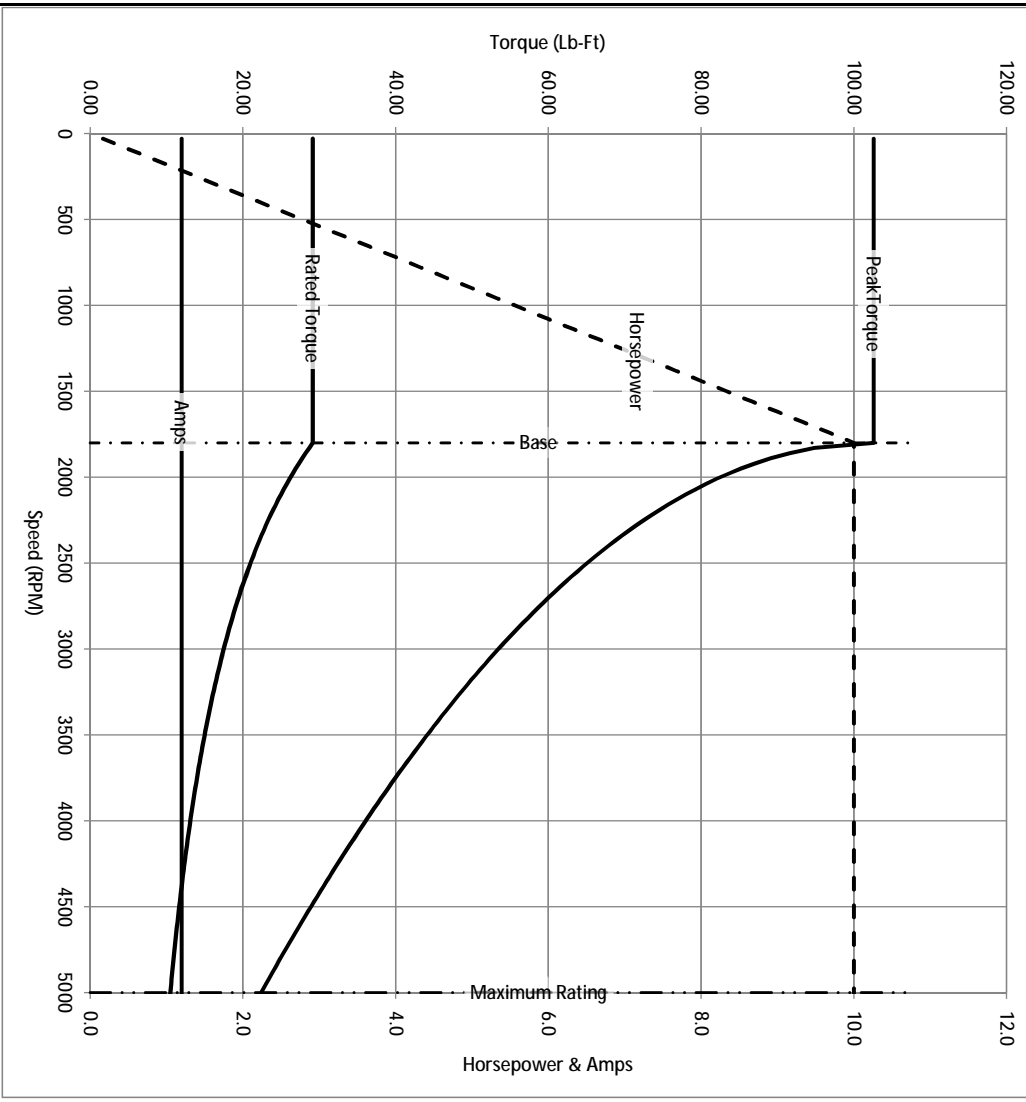

Remarks: Calculated Data

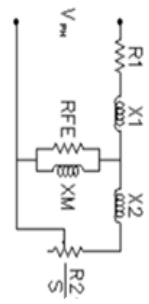

BALDOR
A MEMBER OF THE ABB GROUP

DR BY ENR
CK BY
APP BY ENR
DATE 3/6/2013

A-C MOTOR
PERFORMANCE CURVES

39S001W632Z1

ISSUE DATE 3/6/2013

39LYS001

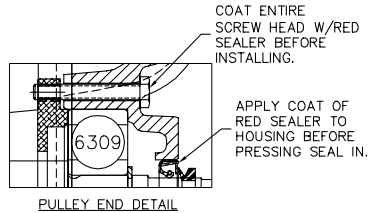
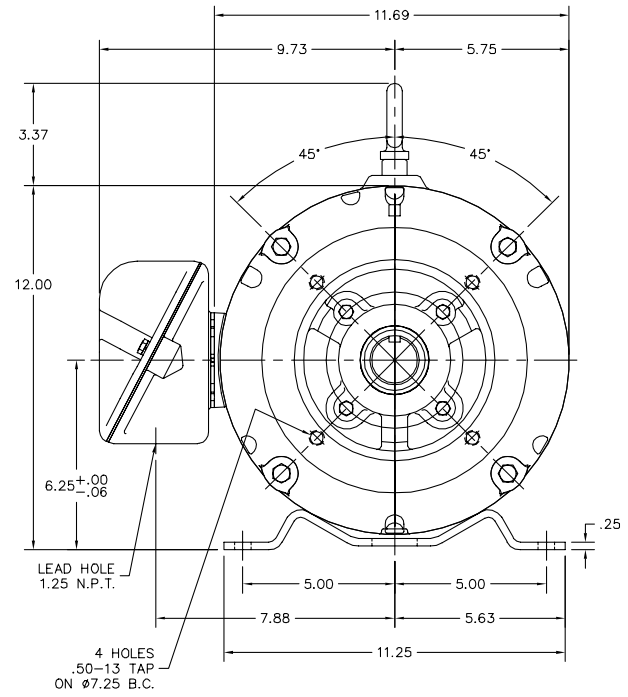
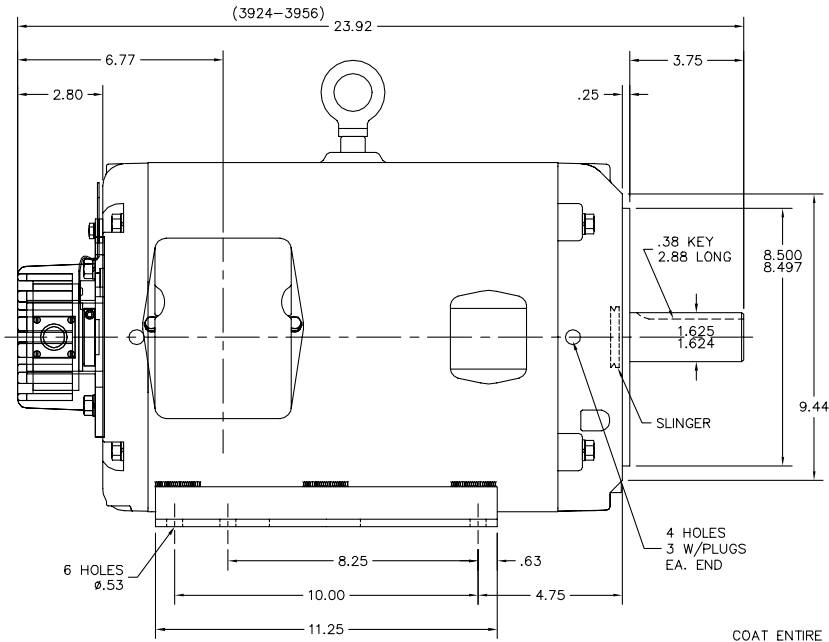

CUSTOMER IS RESPONSIBLE FOR DETERMINING THAT BALDOR'S PRODUCT WILL PERFORM SUITABLY IN THE INTENDED APPLICATION.

REV. DESC: UPDATED DESCRIPTION		
REV. LTR: C	VERSION: 03	TDR: 000000855568
FILE: \AAA\00093\165	REVISED: 04:12:55 05/28/2014	BY: ENNINDO
MTL: -		

BALDOR

HORZ TENV 254-6TC WD VECT W/THRU SH. ENCOD. DESIGN & CVR
SH 1 of 1

39LYS001

CD0005



LOW VOLTAGE
(2Y)



LINE

HIGH VOLTAGE
(1Y)



LINE

NOTES:

1. INTERCHANGE ANY TWO LINE LEADS TO REVERSE ROTATION.
2. OPTIONAL THERMOSTATS ARE PROVIDED WHEN SPECIFIED.
3. ACTUAL NUMBER OF INTERNAL PARALLEL CIRCUITS MAY BE A MULTIPLE OF THOSE SHOWN ABOVE.
4. LEAD COLORS ARE OPTIONAL. LEADS MUST ALWAYS BE NUMBERED AS SHOWN.

REV. DESC: REVISE TO SHOW OPTIONAL COLORS			
REV. LTR: E	BY: JLP	REVISED: 01/19/99 10:15	TDR: 0171435
90000		FILE: AAA00005140	MDL: -
		MTL: -	

BALDOR ELECTRIC Co.

3PH, DV, 9 LEADS

CD0005