

BERKELEY® PUMPER™ & PUMPER PLUS™ GAS ENGINE DRIVE PUMPS

The BERKELEY Pumper™ and Pumper Plus™ series pumps are robust, versatile and designed for portability, typically where electrical power is not readily available.

Applications

- ▶ Tank filling
- ▶ Irrigation
- ▶ Chemical solution transfer
- ▶ General water transfer
- ▶ Boom spray
- ▶ Dewatering

Features / Benefits

- ▶ **30% glass-filled nylon impeller**
Solid construction with proven reliability makes this impeller suitable for pumping clean or brackish water and many farm chemicals.*
- ▶ **Powder coated high grade alloy casing and yoke**
High quality and durable coating protects the outer surface from corrosion.
- ▶ **Quick Fill 2" priming port**
Allows for rapid priming of pump casing.
- ▶ **Built in non-return valve. Easy access for service or replacement**
All pumps require priming. With our built-in non-return valve, once the initial prime is complete you will not have to worry about re-priming. This feature saves you time when time is of the essence.
- ▶ **Three way discharge**
BERKELEY pumps are used for many different fluid transfer applications. A multiple outlet discharge allows for numerous connections at the same time.
- ▶ **Robin gas engine**
Robin engines are reliable, high performance engines that are easy to start. They feature the added safety of a built-in oil alert.
- ▶ **Carry handle**
The safe grip carrying handle increases portability making these units quick to pick up and easier to move when required.

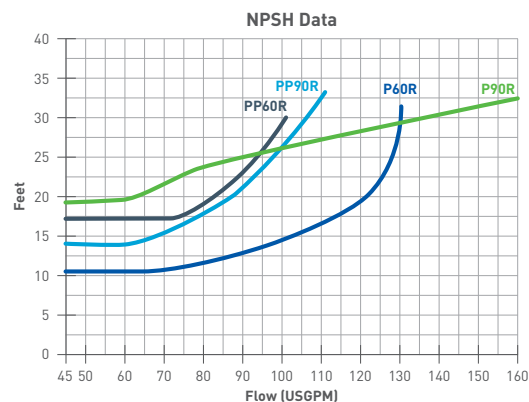
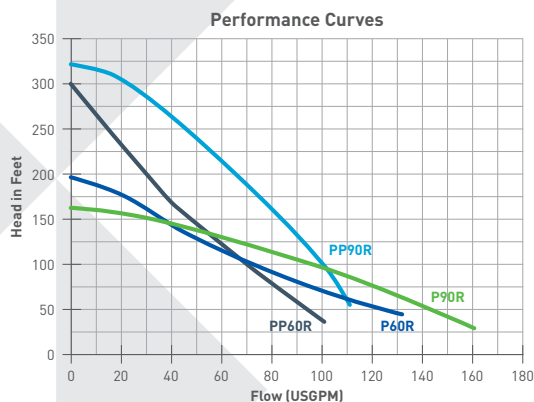

BERKELEY® PUMPER™ & PUMPER PLUS™

Typical Applications

Suitable for pumping clean, non-aggressive liquids and compatible chemicals, with some suspended solids.

Fluid	Water*
Casing pressure	190 PSI (1300 kpa) max.
Liquid temperature	130° F (55° C) max.
Ambient temperature	104° F (40° C) max.
Solid size	1/8" (3 mm) sphere max.

* Capable of handling some chemicals. Check with your local BERKELEY Distributor for compatibility.

** Engine performance is reduced with increased ambient temperature and/or altitude. Please consult factory for performance corrections at ambient temperatures over 104° F or elevations above 6000 ft.

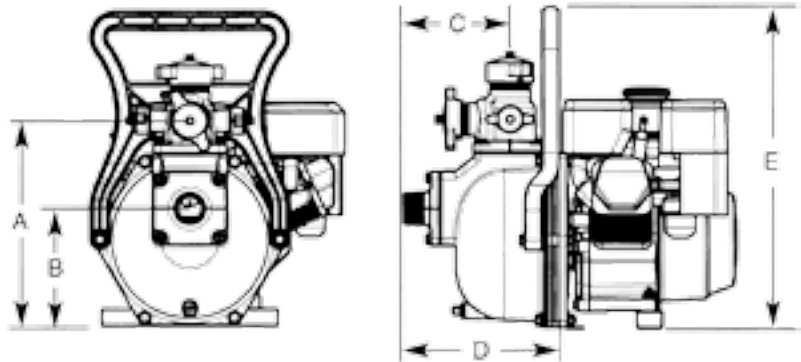

Accessories

Roll cage is optional on all models (Dimensions are: 21 "H x 26"W x 20"D)

Materials of Construction

Component	Material
Pump casing	Powder coated aluminum
Impeller	30% glass-filled nylon
Diffuser	Aluminum
Motor shaft	Mild steel
O-rings	Nitrile
Discharge caps	Polypropylene
Discharge washers	Arnetal
Priming cap	30% glass-filled nylon
Drain plug	Polypropylene

Mechanical seal, Type 6 or Equivalent

Flexible bellows	Nitrile
Stationary face	Ceramic
Rotating face	Carbon
Spring	18-8 Stainless steel

Pump Dimensions

Pump Model	Engine Make	Engine HP	A (in)	B (in)	C (in)	D (in)	E (in)	Pump wt. (lbs.)
P60R	Robin EX17	6.0	12.3	7.0	6.5	10.0	18.9	53
P90R	Robin EX27	9.0	12.5	7.2	6.6	10.7	19.1	66
PP60R	Robin EX17	6.0	12.3	7.0	6.5	10.0	18.9	57
PP90R	Robin EX27	9.0	12.5	7.2	6.6	10.7	19.1	68

Pump and Engine Data

Pump Model	Engine Make	Suction Male	3 Way Discharge	Drain Plug	Shaft Thread	Tank Volume	Fuel Type
P60R	Robin EX17	1.5"	1", 1", 1.5"	1/4"	5/8"	1.0 Gal.	Gas
P90R	Robin EX27	2.0"	1", 1", 2"	1/4"	1"	1.6 Gal.	Gas
PP60R	Robin EX17	2.0"	1", 1", 2"	1/4"	5/8"	1.0 Gal.	Gas
PP90R	Robin EX27	2.0"	1", 1", 2"	1/4"	1"	1.6 Gal.	Gas

Note: All engines are rewind start, OHC.



293 WRIGHT STREET, DELAVAN, WI 53115 WWW.BERKELEYPUMPS.COM
PH: 888-237-5353 ORDERS FAX: 800-321-8793

Because we are continuously improving our products and services, Pentair reserves the right to change specifications without prior notice.