



AQUAVAR[®] CPC - FD

Variable Speed Drive with Fused Disconnect

SUPPLEMENT TO THE INSTALLATION AND OPERATION MANUAL (IM167)

TABLE OF CONTENTS

SAFETY

Use of Warnings and Notes.....	3
--------------------------------	---

INSTALLATION

Application	4
Input Disconnect Features and Functions	4
Installation Flow Chart.....	6
Preparing for Installation (Supplement to Aquavar CPC-01/U1 User’s Manual).....	7
Installing the Drive (Supplement to Aquavar CPC-01/U1 User’s Manual).....	9
Installing the Wiring (Supplement to Aquavar CPC-01/U1 User’s Manual)	10

MAINTENANCE

Maintenance Intervals	14
Drive Module Fan Replacement	14
Enclosure Fan Replacement - NEMA 12 Enclosures	15
Enclosure Air Filter Replacement - NEMA 12 Enclosures.....	16

TECHNICAL DATA

Ratings (Supplement to Aquavar CPC-01/U1 User’s Manual).....	19
Input Power Connections (Supplement to Aquavar CPC-01/U1 User’s Manual)	20
Motor Connections.....	26
Cooling - R7/R8.....	26
Dimensions and Weights (Supplement to Aquavar CPC-01/U1 User’s Manual).....	27
Applicable Standards.....	34

INDEX

SAFETY



WARNING! The AQUAVAR CPC adjustable speed AC drive with Input Disconnect should ONLY be installed by a qualified electrician.



WARNING! Even when the motor is stopped, dangerous voltage is present at the Power Circuit terminals U1, V1, W1 and U2, V2, W2 and, depending on the frame size, UDC+ and UDC-, or BRK+ and BRK-.



WARNING! Dangerous voltage is present when input power is connected. After disconnecting the supply, wait at least 5 minutes (to let the intermediate circuit capacitors discharge) before removing the cover.



WARNING! Even when power is removed from the input terminals of the AQUAVAR CPC, there may be dangerous voltage (from external sources) on the terminals of the relay outputs.



WARNING! When the control terminals of two or more drive units are connected in parallel, the auxiliary voltage for these control connections must be taken from a single source which can either be one of the units or an external supply.



WARNING! The AQUAVAR CPC will start up automatically after an input voltage interruption if the external run command is on.



WARNING! When the AQUAVAR CPC with Input Disconnect is connected to the line power, the Motor Terminals T1, T2 and T3 are live even if the motor is not running. Do not make any connections when the AQUAVAR CPC with Input Disconnect is connected to the line. Disconnect and lock out power to the drive before servicing the drive. Failure to disconnect power may cause serious injury or death.

NOTE! For more technical information, contact the factory or your local AQUAVAR representative.

USE OF WARNINGS AND NOTES

There are two types of safety instructions throughout this manual:

- Notes draw attention to a particular condition or fact, or give information on a subject.
- Warnings caution you about conditions which can result in serious injury or death and/or damage to the equipment. They also tell you how to avoid the danger. The warning symbols are used as follows:



DANGEROUS VOLTAGE WARNING warns of high voltage which can cause physical injury and/or damage to the equipment.



GENERAL WARNING warns about conditions, other than those caused by electricity, which can result in physical injury and/or damage to the equipment.

INSTALLATION

Study these installation instructions carefully before proceeding. Failure to observe the warnings and instructions may cause a malfunction or personal hazard.



WARNING! Before you begin read "Safety" on page 3.



WARNING! When the Aquavar CPC with Input Disconnect is connected to the line power, the Motor Terminals T1, T2, and T3 are live even if the motor is not running. Do not make any connections when the Aquavar CPC with Input Disconnect is connected to the line. Disconnect and lock out power to the drive before servicing the drive. Failure to disconnect power may cause serious injury or death.

Application

This manual contains supplemental information that is unique to Aquavar CPC input disconnect configurations ("FD" suffix). Refer to the base manual, Aquavar CPC User's Manual (IM167), for all other information.

Input Disconnect Features and Functions

The Aquavar CPC with Input Disconnect is an Aquavar CPC AC adjustable frequency drive packaged with an input disconnect switch, and with a door mounted, external operating handle. The operating handle can be padlocked in the OFF position (padlock not supplied). Enclosure options are NEMA 1, NEMA 12 and NEMA 3R (UL Type 1, UL Type 12 and UL Type 3R).

The following is a typical power diagram:

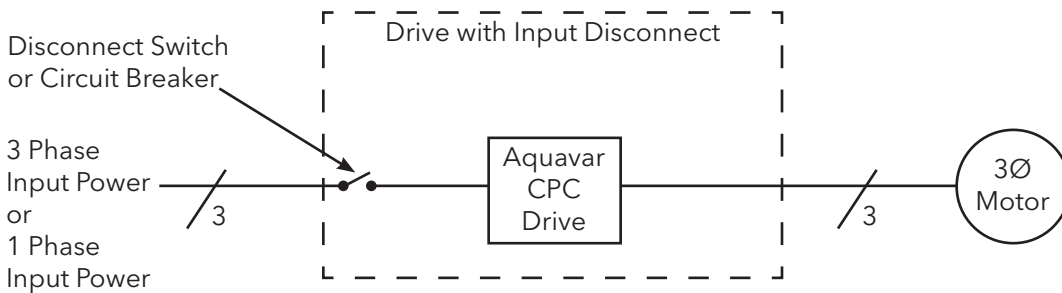

INSTALLATION

The following figures show the front view of the Aquavar CPC Input Disconnect standard configurations and identify the major components.

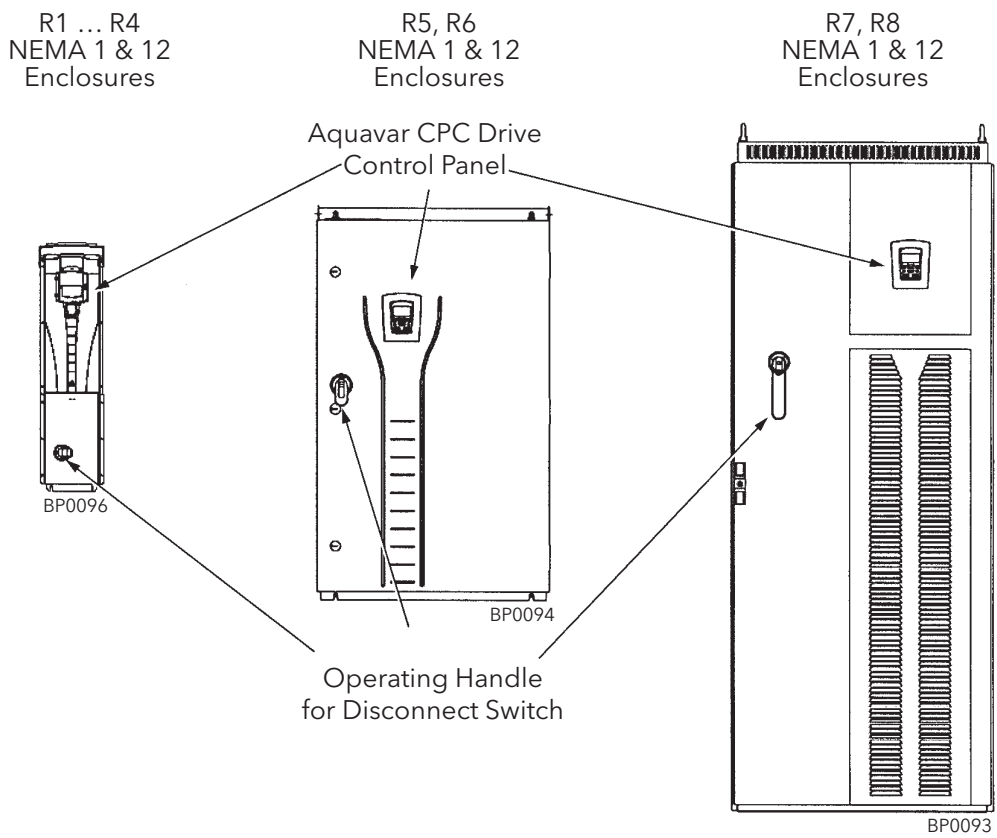

INSTALLATION

Installation Flow Chart

The installation of Input Disconnect configurations for Aquavar CPC drives follows the outline below. The steps must be carried out in the order shown. At the right of each step are references to the detailed information needed for the correct installation of the unit.

NOTE! References in the middle column below are to the Aquavar CPC User’s Manual (IM167). References in the third column below are to this manual.

Task	Refer to the Aquavar CPC User’s Manual “Installation” Section	Additional Reference in this Manual
<div style="border: 1px solid black; padding: 5px; width: fit-content;"> PREPARE for installation </div>	“Preparing for Installation”	<ul style="list-style-type: none"> • R7/R8: “Lifting the Drive” on page 7. • “Drive Identification” on page 8. • “Suitable Mounting Location” on page 9.
<div style="border: 1px solid black; padding: 5px; width: fit-content;"> PREPARE the Mounting Location </div>	“Prepare the Mounting Location”	<ul style="list-style-type: none"> • R7/R8: “Prepare the Mounting Location – R7 and R8” on page 9. • “Dimensions and Weights (Supplement to Aquavar CPC User’s Manual)” on page 27.
<div style="border: 1px solid black; padding: 5px; width: fit-content;"> REMOVE the front cover </div>	“Remove Front Cover”	R7/R8: “Remove Side Panel- R7 and R8 NEMA 1 and 12 Enclosures” on page 9.
<div style="border: 1px solid black; padding: 5px; width: fit-content;"> MOUNT the drive </div>	“Mount the Drive”	R7/R8: “Mount the Drive” on page 10.
<div style="border: 1px solid black; padding: 5px; width: fit-content;"> INSTALL wiring </div>	“Wiring Overview” and “Install the Wiring”	“Installing the Wiring (Supplement to Aquavar CPC User’s Manual)” starting on page 10.
<div style="border: 1px solid black; padding: 5px; width: fit-content;"> CHECK installation </div>	“Check Installation”	–
<div style="border: 1px solid black; padding: 5px; width: fit-content;"> REINSTALL the cover </div>	“Reinstall Cover”	–
<div style="border: 1px solid black; padding: 5px; width: fit-content;"> APPLY power </div>	“Apply Power”	–
<div style="border: 1px solid black; padding: 5px; width: fit-content;"> START-UP </div>	“Start-Up”	–

INSTALLATION

Preparing for Installation (Supplement to Aquavar CPC User's Manual)

Lifting the Drive

R7...R8 Frames



WARNING! Handle and ship floor mounted enclosures only in the upright position. These units are not designed to be laid on their backs.

1. Use a pallet truck to move the package/enclosure to the installation site.

2. Remove the cabinet side panels from NEMA 1 and 12 enclosures for access to the cabinet/pallet mounting bolts. (Six (6) torx screws hold each cabinet side panel in place. Leave the side panels off until later.)

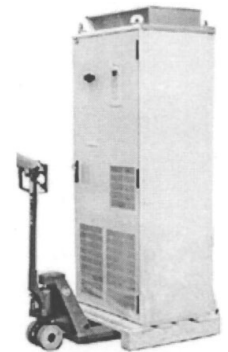

PC00005

3. Remove the 4 bolts that secure the cabinet to the shipping pallet.



WARNING! Use the lifting lugs/bars at the top of the unit to lift R7/R8 drives.

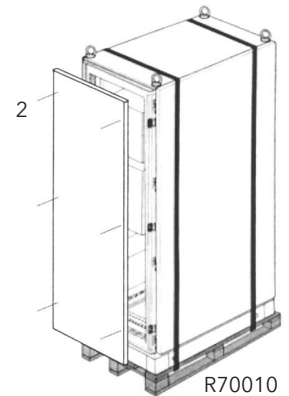

R70010

4. Use a hoist to lift the drive. (Do not place drive in final position until mounting site is prepared.)

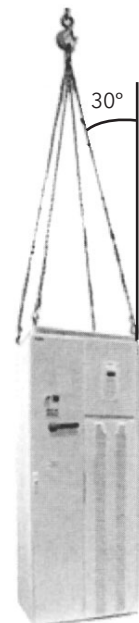

PC00003

INSTALLATION

Preparing for Installation (Supplement to Aquavar CPC User's Manual)

Drive Identification

To identify the type of device you are installing, refer to the type code number on the device identification label.

- Wall mounting base drives - label attached on the side surface of the heat sink.
- Packaged drive with screw cover - label attached to outside surface on the left side of the enclosure.
- Enclosure with hinged cover/door - label on inside surface of the cover/door.

Type Code Number

Use the following to interpret the type code found on the identification label.

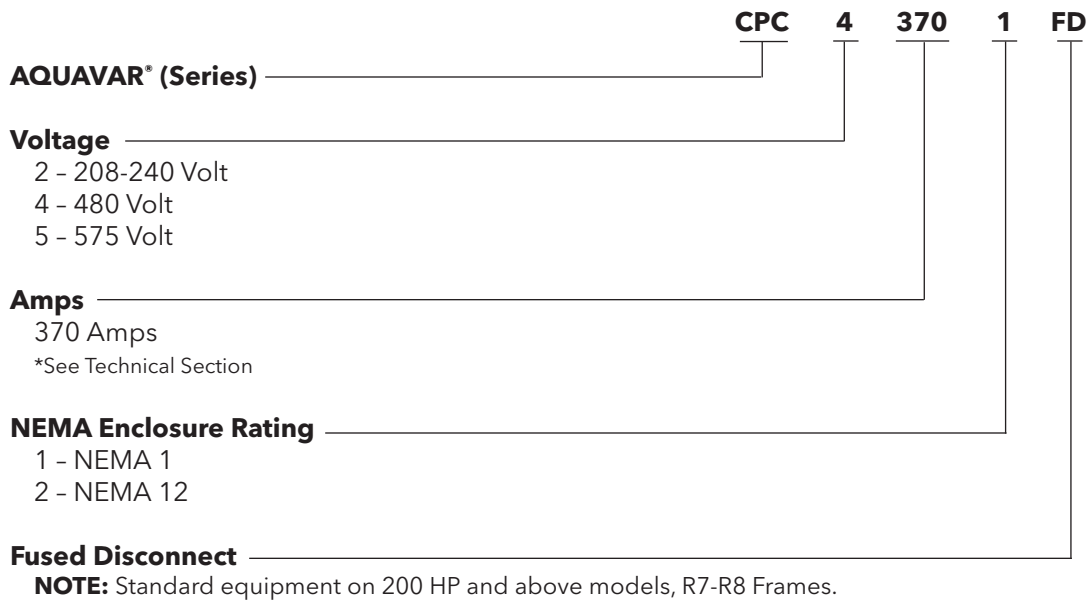

Options

* Consult factory for other options, if available. Not all combinations may be available.

Ratings and Frame Size

Charts in the "Ratings" sections of the Aquavar CPC User's Manual and this manual list technical specifications, and identify the drive's frame size.

NOTE! Some instructions in this document vary, depending on the drive's frame size. To read the Ratings table, you need the "Output current rating" entry from the type code (see above).

INSTALLATION

Suitable Mounting Location

For selecting a suitable mounting location for FD configurations, refer to:

- Preparing for installation in the Aquavar CPC User's Manual, and
- The Technical Data section of this manual for information on dimensions and weights.

Installing the Drive (Supplement to Aquavar CPC User's Manual - IM167)



WARNING! Metal shavings or debris in the enclosure can damage electrical equipment and create a hazardous condition. Where parts, such as conduit plates require cutting or drilling, first remove the part. If that is not practical, cover nearby electrical components to protect them from all shavings or debris.

Prepare the Mounting Location - R7 and R8

The Aquavar CPC should only be mounted where all of the requirements defined in "Preparing for Installation" are met.

Frame sizes R7 and R8 have mounting holes inside the enclosure base. See "NEMA 1 and 12, R7...R8 Mounting Dimensions" on page 28.

Where it is not possible to use either mounting hole at the back of the base, use an L-bracket at the top of the enclosure to secure the cabinet to a wall or to the back of another enclosure. Bolt the L-bracket to the enclosure using the lifting lug bolt hole on the top of the enclosure.

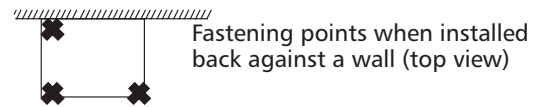
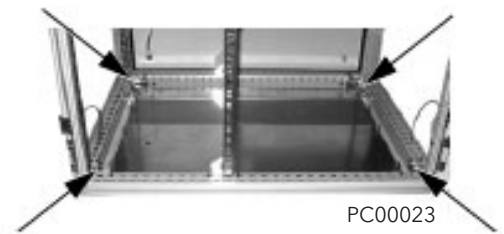

Fastening points when installed back against a wall (top view)

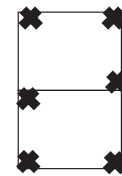

Fastening points when installed back against back

Fastening the cabinet at the top using L-brackets (side view)

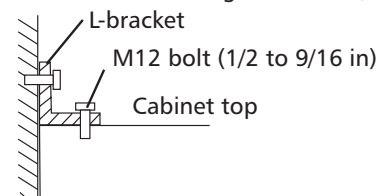

Remove Side Panels - R7 and R8 NEMA 1 and 12 Enclosures

Cabinet Door

1. To open the cabinet door, loosen the quarter-turn screws that hold the cabinet door closed.
2. Installation access is easier if these panels are kept off throughout the installation.

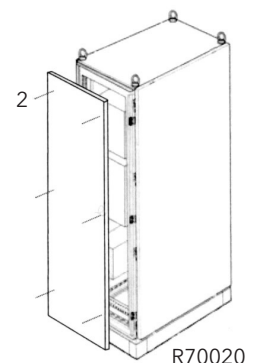

INSTALLATION

Mount the Drive

R7...R8

1. Use a hoist to move the cabinet into position.

NOTE! If the cabinet location does not provide access to the cabinet sides, be sure to re-mount side panels before positioning cabinet.



PC00003

2. Install and tighten mounting bolts.

Installing the Wiring (Supplement to Aquavar CPC User's Manual)



WARNING!

- Metal shavings or debris in the enclosure can damage electrical equipment and create a hazardous condition. Where parts, such as conduit plates require cutting or drilling, first remove the part. If that is not practical, cover nearby electrical components to protect them from all shavings or debris.
- Do not connect or disconnect input or output power wiring, or control wires, when power is applied.
- Never connect line voltage to drive output Terminals T1, T2 and T3.
- Do not make any voltage tolerance tests (Hi Pot or Megger) on any part of the unit. Disconnect motor wires before taking any measurements in the motor or motor wires.
- Make sure that power factor correction capacitors are not connected between the drive and the motor.

Wiring Requirements

Refer to the "Wiring Requirements" Section in the Aquavar CPC User's Manual. The requirements apply to all Aquavar CPC drives. In particular:

- Use separate, metal conduit runs for the following different classes of wiring:
 - Input power wiring
 - Motor wiring
 - Control/communications wiring
- Properly and individually ground the drive, the motor and cable shields.
- **Ground the pressure transducer** or piping back to the Aquavar chassis or common grounding point.

INSTALLATION

Wiring Overview

Power Connection - Standard Input Disconnect (R1...R6, Wall Mounted)

The following figures show the Standard Input Disconnect (wall mounted) wiring connection points. Refer to the Aquavar CPC User's Manual for control connections to the drive.

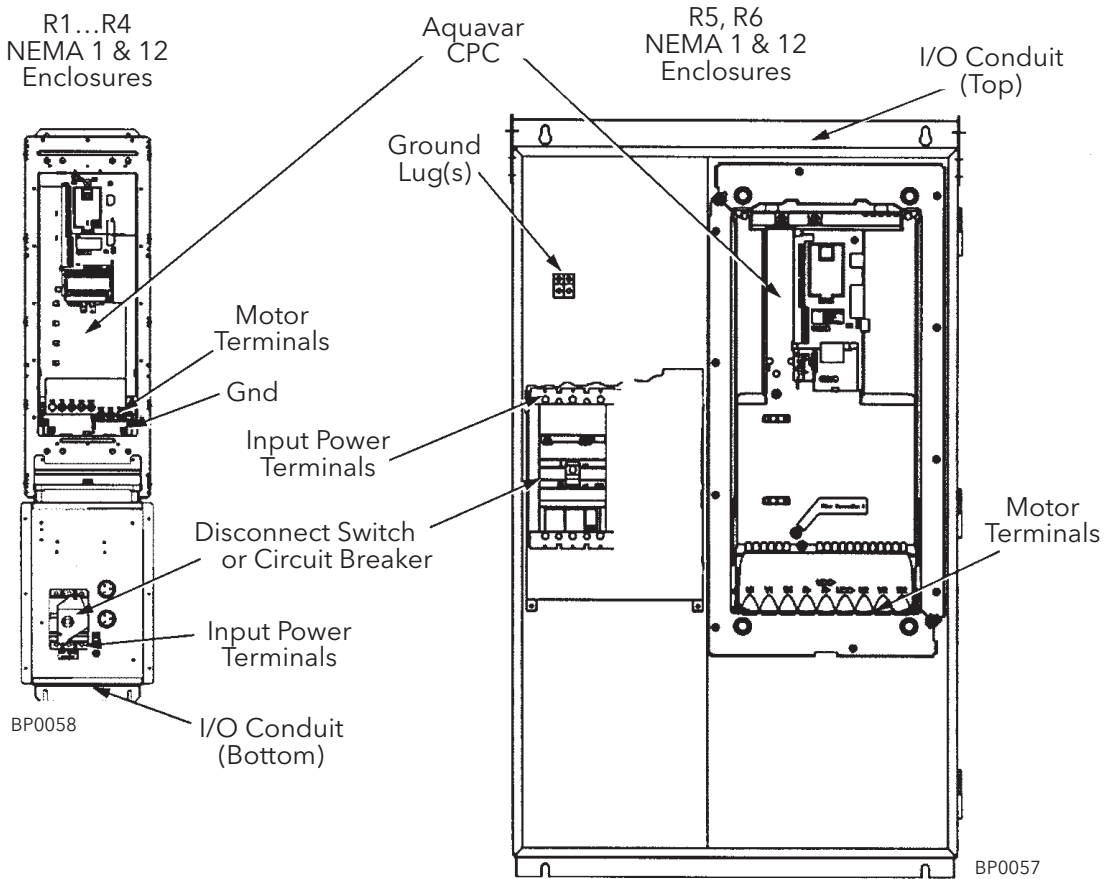

INSTALLATION

Power Connection - Standard Input Disconnect (R7...R8, Floor Mounted)

The R7 and R8 Aquavar CPC Standard Input Disconnect units are configured for wiring access from the top and include a removable conduit mounting plate. The following figure shows the Standard Input Disconnect (floor mounted) wiring connection points. Refer to the Aquavar CPC User's Manual for control connections to the drive.

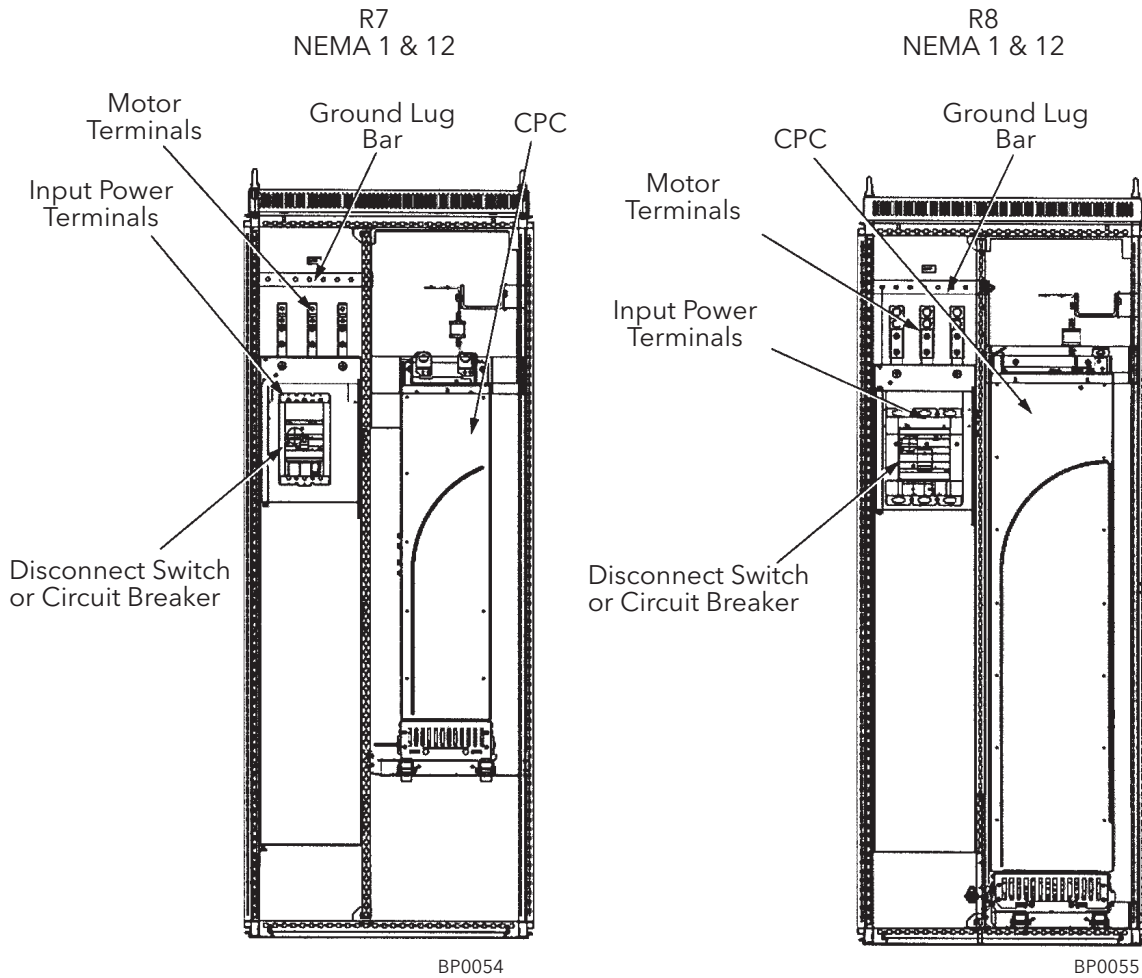

INSTALLATION

Install the Line Input Wiring

Line Input Connections - Standard Input Disconnect Configurations

Connect input power to the terminals of the disconnect switch or circuit breaker. Connect the equipment grounding conductor to the ground lug. The figure below shows the connection points for Standard Input Disconnect configurations.

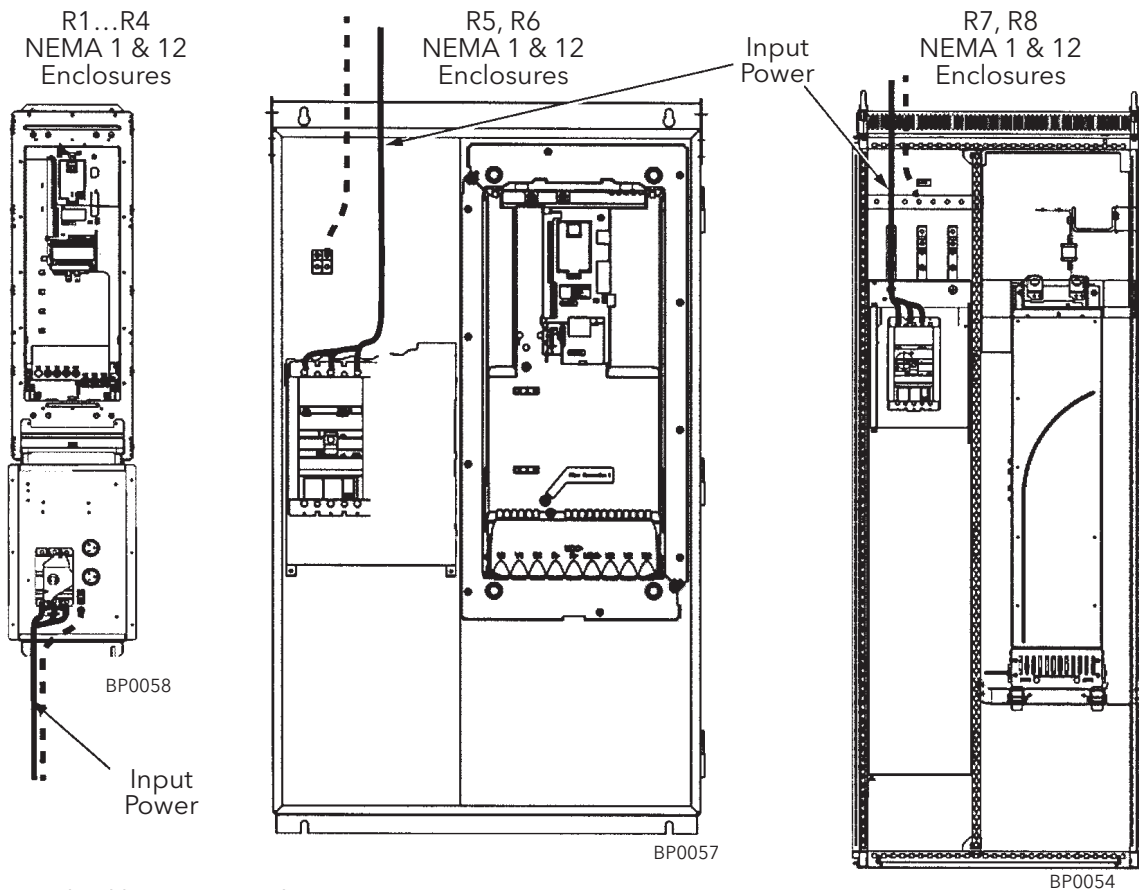

R7 shown.
R8 similar to R7.



WARNING! Check the motor and motor wiring insulation before connecting the Aquavar CPC to line power. Follow the procedure in the Aquavar CPC User's Manual. Before proceeding with the insulation resistance measurements, check that the Aquavar CPC is disconnected from incoming line power. Failure to disconnect line power could result in death or serious injury.

NOTE! For the remainder of the installation and start-up (motor and control wiring) refer to the Aquavar CPC User's Manual.

MAINTENANCE

Maintenance Intervals

If installed in an appropriate environment, the drive requires very little maintenance. This table lists the routine maintenance intervals recommended by CentriPro.

Maintenance	Configuration	Interval	Instruction
Check/replace R5/R6 enclosure inlet air filter	R5/R6 NEMA 12 enclosures	Check every 3 months. Replace as needed.	"Frame Sizes R5/R6 - Enclosure Inlet Air Filter" on page 16.
Check/replace R7/R8 enclosure inlet air filter	R7/R8 NEMA 12 enclosures	Check every 3 months. Replace as needed.	"Frame Sizes R7/R8 - NEMA 12 Enclosure Inlet Air Filter" on page 16.
Check/replace R7/R8 enclosure exhaust air filter	R7/R8 NEMA 12 enclosures	Check every 6 months. Replace as needed.	"Frame Sizes R7/R8 - NEMA 12 Enclosure Exhaust Filters" on page 18.
Check and clean heatsink	All	Depends on the dustiness of the environment (every 6...12 months)	See "Maintenance" in Aquavar CPC User's Manual.
Replace drive module fan	All	Every 6 years	See "Maintenance" in Aquavar CPC User's Manual.
Replace enclosure fan(s)	NEMA 12	Every 3 years	See "Frame Sizes R7/R8 - NEMA 12 Enclosures" on page 15. For other frame sizes, see "Maintenance" in Aquavar CPC User's Manual.
Change capacitor	Frame sizes R5 and R6	Every 10 years	See "Maintenance" in Aquavar CPC User's Manual.
Replace battery in the Assistant control panel	All	Every 10 years	See "Maintenance" in Aquavar CPC User's Manual.

Drive Module Fan Replacement

The drive module fan cools the heatsink. Fan failure can be predicted by the increasing noise from fan bearings and the gradual rise in the heatsink temperature in spite of heatsink cleaning. If the drive is operated in a critical part of a process, fan replacement is recommended once these symptoms start appearing. Replacement fans are available from the factory. Do not use other than CentriPro specified spare parts.

To monitor the running time of the cooling fan, see "Group 29: Maintenance Trig" in the Aquavar CPC Users's Manual.

Frame Sizes R7 and R8

Refer to the installation instructions supplied with the fan kit.

MAINTENANCE

Enclosure Fan Replacement - NEMA 12 Enclosures

NEMA 12 enclosures include an additional fan (or fans) to move air through the enclosure.

Frame Sizes R7/R8 - NEMA 12 Enclosures

The enclosure fan is located in the exhaust box on top of the NEMA 12 enclosure.

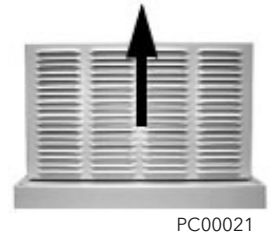

1. Remove the left and right filter frames of the exhaust fan box by lifting them upwards.
2. Disconnect the fan's electrical connector from the cabinet roof (top right Inside the cabinet).
3. Undo the four fastening screws at the corners of the fan frame. The screws are through bolts with nuts on the inside of the cabinet. (Do not drop the hardware into the drive).

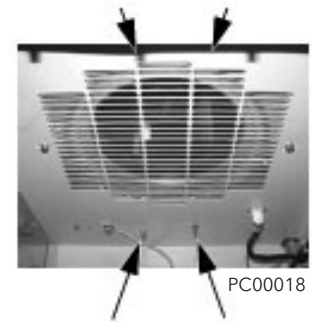

4. Remove the fan and fan frame as one unit.

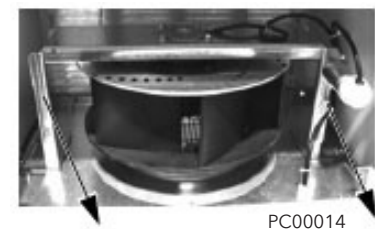

5. Disconnect the fan wiring and capacitor from the fan frame. Then remove the four screws attaching the fan to the fan frame. Remove the old fan.

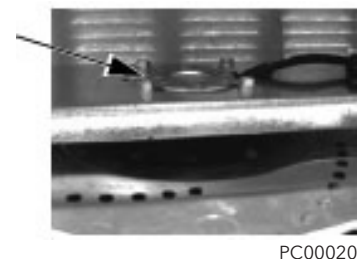

6. Install the new fan and capacitor with the replacement part for CentriPro in the reverse order of the above. Ensure the fan is centered on the velocity stack and rotates freely.

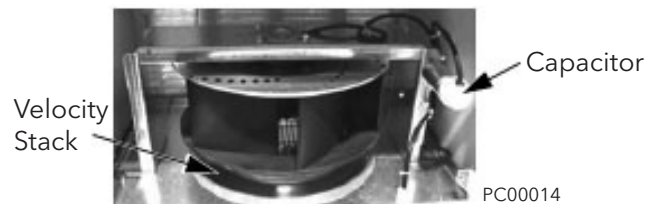

MAINTENANCE

Enclosure Air Filter Replacement - NEMA 12 Enclosures

Frame Sizes R5/R6 - Enclosure Inlet Air Filter

This procedure applies to disconnect configurations in R5 and R6 frame sizes with NEMA 12 enclosures. This filter is located at the bottom of the enclosure. Use the following procedure to check and replace filters.

1. On the enclosure, remove the screw holding the filter bracket in place.
2. Slide the filter bracket forward until the hooks on the bracket clear the slots on the enclosure base. This step allows the filter and bracket to drop free from the enclosure.

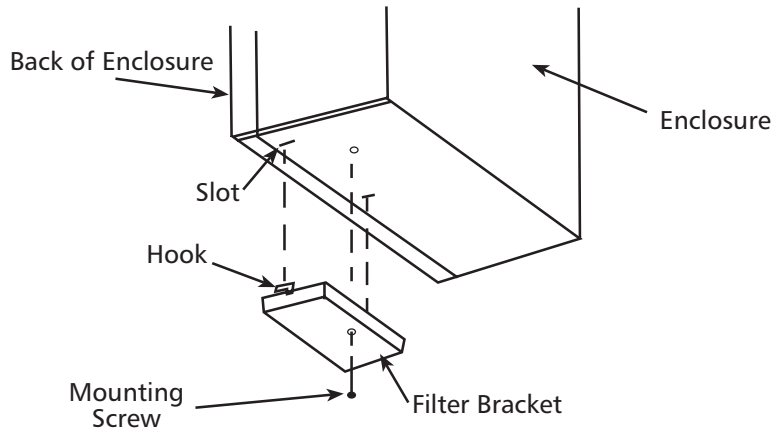

3. Lift the filter out of the filter bracket and replace as appropriate.
4. With the filter in the filter bracket, align the hooks on the bracket with the slots in the enclosure base, and press the hooks up into the slots.
5. Slide the filter bracket back, making sure that the hooks catch on the enclosure.
6. Replace the mounting screw. Tighten until the gasket on the bracket is about 50% compressed.

Frame Sizes R7/R8 - Nema 12 Enclosure Inlet Air Filter

The inlet air filter for the R7/R8 NEMA 12 enclosure is located in the enclosure front door.

1. While holding the top of the filter frame, pull up on the bottom of the frame. The filter frame will slide up approximately $\frac{3}{4}$ inch and can then safely removed by tilting away from the cabinet and lifting up.

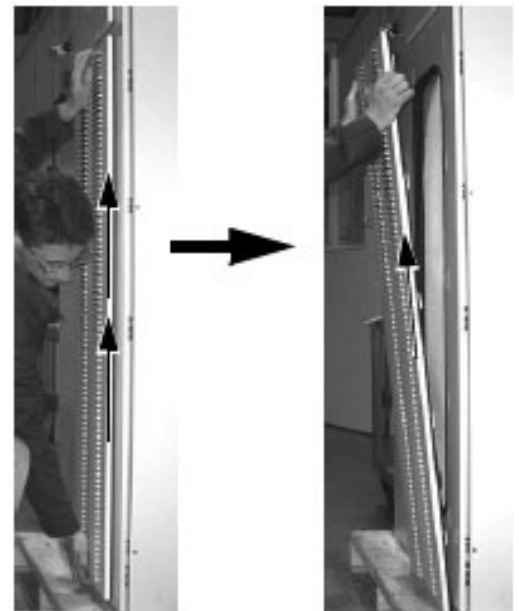

PC00015

PC00010

MAINTENANCE

2. Lay the filter frame on a flat work surface. Remove the 3 retaining brackets by squeezing the tabbed corners in towards the middle of each bracket until the bracket clears the filter frame. Save these brackets for replacement. Remove and inspect the filter.

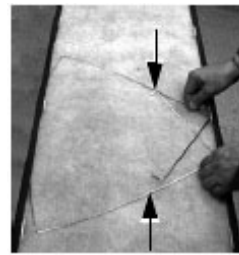

PC00009

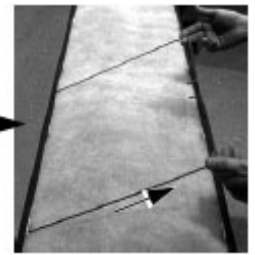

PC00007

3. Install the replacement filter. Be sure to tuck the filter into the groove around the entire filter frame. This is very important for proper installation.



PC00013

4. Reinstall the 3 filter restraining brackets. These will prevent the filter from being pulled out of the filter frame.

- Install the center bracket first.
- Install the 2nd bracket overlapping the center bracket by $\frac{1}{2}$ to the left.
- Install the 3rd bracket overlapping the center bracket by $\frac{1}{2}$ to the right.



PC00007

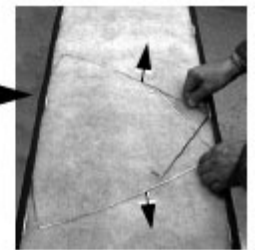

PC00009



1st filter retaining bracket



1st and 2nd filter retaining brackets



All 3 filter retaining brackets

5. Install the filter frame back to the cabinet door. Carefully align the mounting hooks to the slots in the cabinet door. The hooks should be pointing down. Press in at the center of the filter frame with your knee and gently press down with your hands at the top of the frame. The filter frame will slide down approximately $\frac{3}{4}$ inch and should be sealed securely to the door around the entire filter frame.



PC00006



PC00008

MAINTENANCE

Frame Sizes R7/R8 - NEMA 12 Enclosure Exhaust Filters

The exhaust filters in the R7/R8 NEMA 12 enclosure are located in the exhaust box at the top of the enclosure.

There are 2 filter frames attached to the exhaust box.

1. Remove each filter frame:

- Lift up on the filter frame until it slides approximately $\frac{3}{4}$ inch.
- Pull away from the exhaust box to remove.



PC00021

2. For each filter frame, remove the wire retainers that hold the filters in place:

- Lay the filter frames on a flat work surface.
- The wire retainers have a square "U" shape. Remove by squeezing the open end of the "U" towards the middle of the "square" until the retainer top (open end of "U") clears the filter frame.
- Save the retainers for reinstallation.

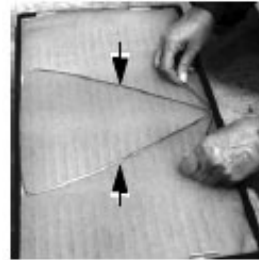

PC00001

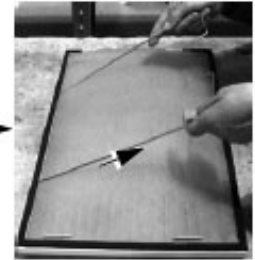

PC00019

3. Remove and inspect the filter.

4. Install clean filters.

NOTE! When installing DUSTLOK® filter media, the white side must face to outside of the cabinet, and the orange side faces in. Be sure to tuck the filter edges into the groove around the entire filter frame. This detail is very important for proper operation.

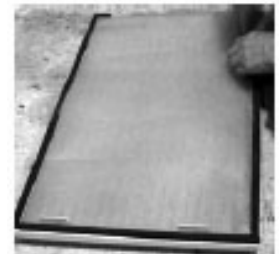

PC00022

5. Reinstall the filter restrainers.

- Insert the base of a retainer (bottom of "U" shape) into a filter frame channel.
- Squeeze the open end of the "U" until it clears the filter frame.
- Seat the open end of the "U" in the filter frame channel.
- Release the retainer to its relaxed, square shape.



PC00019

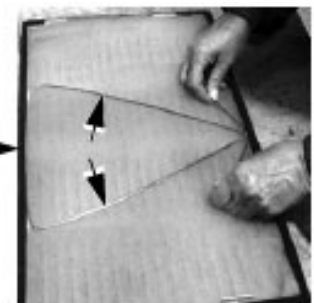

PC00001

6. Install each filter frame to the bonnet on top of the cabinet.

- Carefully align the frame's mounting hooks with the slots in the bonnet. (The hooks should be pointing down.)
- Press down at the top of the filter frame. (The filter frame slides down approximately $\frac{3}{4}$ inch).
- Check all around the filter frame for a secure seal to the exhaust box.



PC00012



PC00011

TECHNICAL DATA

Ratings (Supplement to Aquavar CPC User's Manual - IM167)

NOTE! The ratings listed below are exceptions to the ratings listed in the Aquavar CPC User's Manual.

Ratings, 380...480 Volt Drives

Type Code	Valid up to 40°C (104 °F)				Frame Size
	Normal Use		Heavy-Duty Use		
AQUAVAR CPC-FD- see below	I_{2N} A	P_N HP	I_{2hd} A	P_{hd} HP	
CPC4245xFD	245	200	192	150	R7
CPC4316xFD	316	250	240	200	R8
CPC4368xFD	368	300	302	250	R8
CPC414xFD	414	350	368	300	R8
CPC486xFD	486	400	414	350	R8
CPC526xFD	526	450	477	400	R8
CPC602xFD	602	500	515	450	R8
CPC645xFD	645	550	590	500	R8

NOTE: I_{2N} = Motor current draw normal
 P_N = Normal rated power
 I_{2hd} = Heavy-duty current rating
 P_{hd} = Heavy-duty NEMA power rating

TECHNICAL DATA

Input Power Connections (Supplement to Aquavar CPC User's Manual)

Fuses

NOTE! Although fuses listed are similar in functional characteristics to fuses listed in the Aquavar CPC User's Manual, physical characteristics may differ. Fuses from other manufacturers can be used if they meet the functional characteristics of those in these tables.

Drive input fuses are provided to disconnect the drive from power in the event that a component fails in the drive's power circuitry.

208...240 Volt Fuses

208 ... 240 Volt		Base Drive Frame Size	Drive Input Fuse Ratings	
HP	Identification		Amps (600V)	Bussmann Type
1	CPC2004xFD	R1	15	KTK-R-15
2	CPC2007xFD	R1	15	KTK-R-15
3	CPC2012xFD	R1	15	KTK-R-15
5	CPC2017xFD	R1	30	KTK-R-30
7.5	CPC2024xFD	R2	30	KTK-R-30
10	CPC2031xFD	R2	50	JJS-50
15	CPC2046xFD	R3	80	JJS-80
20	CPC2059xFD	R3	80	JJS-80
25	CPC2075xFD	R4	100	JJS-100
30	CPC2088xFD	R4	125	170M1368
40	CPC2114xFD	R4	160	170M1369
50	CPC2143xFD	R6	200	170M1370
60	CPC2178xFD	R6	250	170M1371
75	CPC2221xFD	R6	315	170M1372
100	CPC2248xFD	R6	315	170M1372

NOTE: "x" represents both NEMA 1 and NEMA 12 enclosures.

TECHNICAL DATA

380...480 Volt Fuses

380 ... 480 Volt		Base Drive Frame Size	Drive Input Fuse Ratings	
HP	Identification		Amps (600V)	Bussmann Type
1/1.5	CPC4??x?FD	R1	15	KTK-R-15
2	CPC4??x?FD	R1	15	KTK-R-15
3	CPC4006x?FD	R1	15	KTK-R-15
5	CPC4008x?FD	R1	15	KTK-R-15
7.5	CPC4012x?FD	R1	15	KTK-R-15
10	CPC4015x?FD	R2	30	KTK-R-30
15	CPC4023x?FD	R2	30	KTK-R-30
20	CPC4031x?FD	R3	50	JJS-50
25	CPC4038x?FD	R3	50	JJS-50
30	CPC4044x?FD	R3	100	JJS-100
40	CPC4059x?FD	R4	100	JJS-100
50	CPC4072x?FD	R4	100	JJS-100
60	CPC4077x?FD	R5	125	170M1368
75	CPC4096x?FD	R5	125	170M1368
100	CPC4124x?FD	R6	160	170M1369
125	CPC4157x?FD	R6	200	170M1370
150	CPC4180x?FD	R6	250	170M1371
200	CPC4245x?FD	R7	400	JJS-400
250	CPC4316x?FD	R8	400	JJS-400
300	CPC4368x?FD	R8	400	JJS-400
350	CPC4414x?FD	R8	600	JJS-600
400	CPC4486x?FD	R8	600	JJS-600
450	CPC4526x?FD	R8	800	JJS-800
500	CPC4602x?FD	R8	800	JJS-800
550	CPC4645x?FD	R8	800	JJS-800

NOTE: "x" represents both NEMA 1 and NEMA 12 enclosures.

TECHNICAL DATA

500...600 Volt Fuses

500 ... 600 Volt		Base Drive Frame Size	Drive Input Fuse Ratings	
HP	Identification		Amps (600V)	Bussmann Type
2	CPC5002xFD	R2	15	KTK-R-15
3	CPC5004xFD	R2	15	KTK-R-15
5	CPC5006xFD	R2	15	KTK-R-15
7.5	CPC5009xFD	R2	15	KTK-R-15
10	CPC5011xFD	R2	30	KTK-R-30
15	CPC5017xFD	R2	30	KTK-R-30
20	CPC5022xFD	R3	50	JJS-50
25	CPC5027xFD	R3	50	JJS-50
30	CPC5032xFD	R4	100	JJS-100
40	CPC5041xFD	R4	100	JJS-100
50	CPC5052xFD	R4	100	JJS-100
60	CPC5062xFD	R4	100	JJS-100
75	CPC5077xFD	R6	125	170M1368
100	CPC5099xFD	R6	125	170M1368
125	CPC5125xFD	R6	160	170M1369
150	CPC5144xFD	R6	200	170M1370

NOTE: "x" represents both NEMA 1 and NEMA 12 enclosures.

Input Power Cables / Wiring - R7/R8

NEC			
Based on:			
<ul style="list-style-type: none"> • NEC Table 310-16 for copper wires • 90 °C (194 °F) wire insulation • 40 °C (104 °F) ambient temperature • Not more than three current-carrying conductors in raceway or cable, or earth (directly buried). • Copper cables with concentric copper shield 			
Max Load Current (A)	Cu Wire Size (AWG/kcmil)	Max Load Current (A)	Cu Wire Size (AWG/kcmil)
345	400 MCM or 2 x 2/0	474	2 x 250
391	500 MCM or 2 x 3/0	534	2 x 300
410	2 x 3/0	615	2 x 350
465	2 x 4/0	711	2 x 500

TECHNICAL DATA

Drive's Power Connection Terminals (Supplement to Aquavar CPC User's Manual)

The following tables show maximum wire size and required tightening torque for incoming power and motor terminals, and grounding terminal lug information.

208...240 Volt, Terminals

208 ... 240 Volt			Power Wiring Data			
HP	Type Code	Frame Size	Circuit Breaker	Dis-connect Switch	Motor Terminals	Ground Lugs NEMA 1 & 12
1	CPC2004xFD	R1	62 in-lbs	7 in-lbs	12 in-lbs	#4 35 in-lbs
2	CPC2007xFD	R1				
3	CPC2012xFD	R1				
5	CPC2017xFD	R1				
7.5	CPC2024xFD	R2	#6	#8 7 in-lbs	#8 12 in-lbs	
10	CPC2031xFD	R2	62 in-lbs	#6 18 in-lbs		
15	CPC2046xFD	R3	#3	#3	#3	#2 50 in-lbs
20	CPC2059xFD	R3	62 in-lbs	18 in-lbs	24 in-lbs	
25	CPC2075xFD	R4	#1/0 62 in-lbs	#1/0 55 in-lbs	#1/0 180 in-lbs	
30	CPC2088xFD	R4	#2/0 200 in-lbs	#1/0 70 in-lbs		
40	CPC2114xFD	R4		#2/0 200 in-lbs		
50	CPC2143xFD	R6	300 MCM 200 in-lbs	300 MCM 200 in-lbs	300 MCM 354 in-lbs	3 x #3/0 250 in-lbs
60	CPC2178xFD	R6				
75	CPC2221xFD	R6				
100	CPC2248xFD	R6	2 x 250 MCM 275 in-lbs	2 x 250 MCM 275 in-lbs	350 MCM 354 in-lbs	

NOTE: "x" represents both NEMA 1 and NEMA 12.

TECHNICAL DATA

380...480 Volt, Terminals

380 ... 480 Volt			Power Wiring Data			
HP	Type Code	Frame Size	Circuit Breaker	Dis-connect Switch	Motor Terminals	Ground Lugs NEMA 1 & 12
3	CPC4006xFD	R1	62 in-lbs	7 in-lbs	12 in-lbs	#4 35 in-lbs
5	CPC4008xFD	R1				
7.5	CPC4012xFD	R1				
10	CPC4015xFD	R2	#6	#8	#8	#2 50 in-lbs
15	CPC4023xFD	R2	62 in-lbs	7 in-lbs	12 in-lbs	
20	CPC4031xFD	R3	#3	#3	#3	
25	CPC4038xFD	R3	62 in-lbs	18 in-lbs	24 in-lbs	
30	CPC4044xFD	R4	#1/0 62 in-lbs	#1 18 in-lbs	#1/0 180 in-lbs	
40	CPC4059xFD	R4		#1/0 55 in-lbs		
50	CPC4072xFD	R4		#1/0 62 in-lbs ²		
60	CPC4077xFD	R4	300 MCM 200 in-lbs	#1/0 70 in-lbs	#2/0 132 in-lbs	3 x #3/0 250 in-lbs
75	CPC4096xFD	R5		300 MCM 200 in-lbs	300 MCM 354 in-lbs	
100	CPC4124xFD	R6				
125	CPC4157xFD	R6				
150	CPC4180xFD	R6	2 x 250 MCM 275 in-lbs	350 MCM 350 in-lbs	2 x 250 MCM 500 in-lbs	5 Bus Bar Holes (13/32" Bolts)
200	CPC4245xFD	R7				
250	CPC4316xFD	R8				
300	CPC4368xFD	R8				
350	CPC4414xFD	R8				
400	CPC4486xFD	R8				
450	CPC4526xFD	R8				
500	CPC4602xFD	R8	3 x 400 MCM 375 in-lbs	2 x 600 MCM 500 in-lbs	3 x 400 MCM 500 in-lbs	
550	CPC4645xFD	R8				

NOTE: "x" represents both NEMA 1 and NEMA 12.

TECHNICAL DATA

500...600 Volt, Terminals

500 ... 600 Volt			Power Wiring Data			
HP	Type Code	Frame Size	Circuit Breaker	Dis-connect Switch	Motor Terminals	Ground Lugs NEMA 1 & 12
2	CPC5002xFD	R2	#6 62 in-lbs	#8 7 in-lbs	#8 12 in-lbs	#4 35 in-lbs
3	CPC5004xFD	R2				
5	CPC5006xFD	R2				
7.5	CPC5009xFD	R2				
10	CPC5011xFD	R2				
15	CPC5017xFD	R2				
20	CPC5022xFD	R3	#3 62 in-lbs	#3 18 in-lbs	#3 24 in-lbs	#2 50 in-lbs
25	CPC5027xFD	R3				
30	CPC5032xFD	R4	#1/0 62 in-lbs	#1 18 in-lbs	#1/0 180 in-lbs	
40	CPC5041xFD	R4				
50	CPC5052xFD	R4		#1/0 55 in-lbs		
60	CPC5062xFD	R4		#1/0 62 in-lbs ²		
75	CPC5077xFD	R6	300 MCM 200 in-lbs	#1/0 70 in-lbs	300 MCM 354 in-lbs	3 x #3/0 250 in-lbs
100	CPC5099xFD	R6				
125	CPC5125xFD	R6				
150	CPC5144xFD	R6				

NOTE: "x" represents both NEMA 1 and NEMA 12.

TECHNICAL DATA

Motor Connections

Motor Connection Specifications - R7/R8

Motor Connection Specifications				
Maximum Motor Cable Length	Frame Size	Maximum Motor Cable Length*		
		f _{sw} = 1 or 4 kHz		f _{sw} = 8 kHz or 12 kHz
	R7...R8	300 m	980 ft	Does not apply



WARNING! Using a motor cable longer than specified in the chart above may cause permanent damage to the drive.

Cooling - R7/R8

Cooling Specifications	
Method	Internal fan, flow direction from bottom to top.
Requirement	• R7/R8: Free space in front of enclosure: 152 mm (6 in).
	• R7/R8: Free space above enclosure: None required for cooling.
	• R7/R8: Free space at sides of enclosure: None required for cooling.
	• R7/R8: Also see "Additional Free Space Recommendations" on page 33.

Air Flow, 380...480 Volt Drives - R7/R8

The following table lists heat loss and air flow data for 380...480 Volt drives.

Drive		Heat Loss		Air Flow	
CPC-xx-	Frame Size	W	BTU/Hr	m ³ /h	ft ³ /min
-245A-4	R7	3850	13000	300	540
-316A-4	R8	5300	18000	700	1220
-368A-4	R8	6850	23000	700	1220
-414A-4	R8	7000	24000	700	1220
-486A-4	R8	7600	26000	700	1220
-526A-4	R8	7800	27000	700	1220
-602A-4	R8	8100	28000	700	1220
-645A-4	R8	9100	31000	700	1220

TECHNICAL DATA

Dimensions and Weights (Supplement to Aquavar CPC User's Manual)

Mounting Dimensions

NEMA 1 & 12, R1...R6 Mounting Dimensions

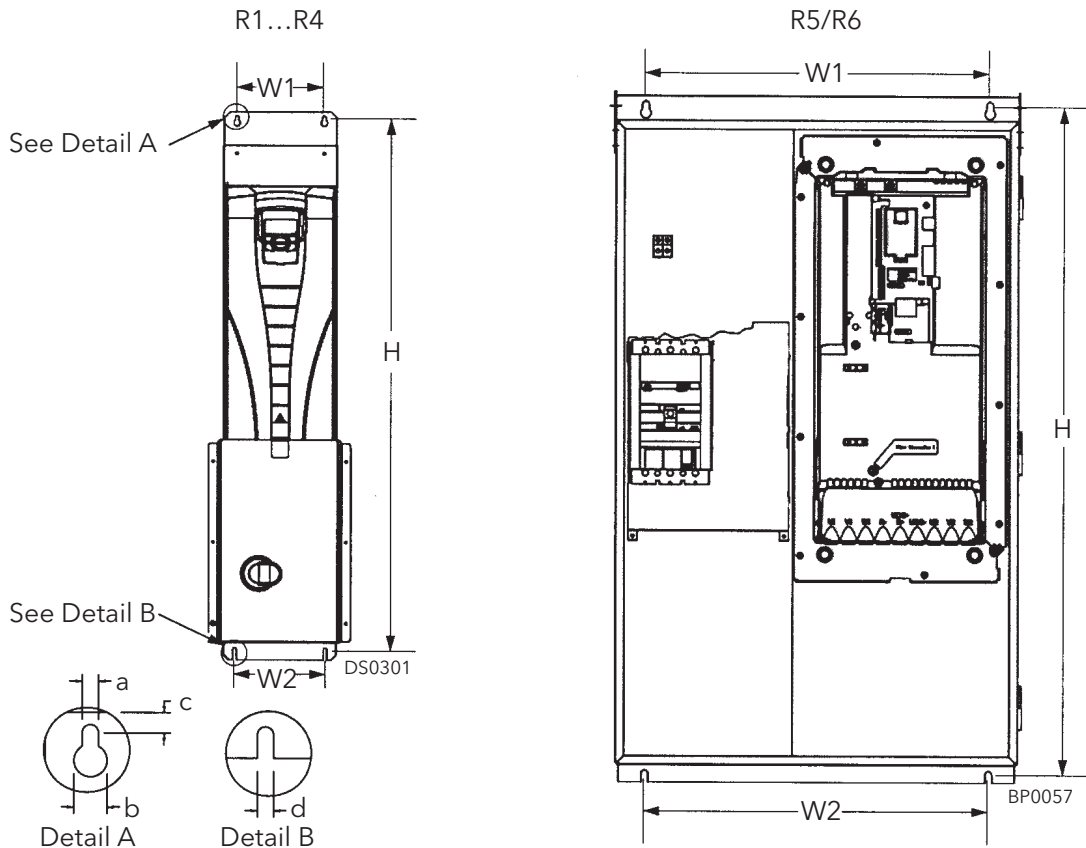

NEMA 1 and NEMA 12 - Mounting Dimensions for each Frame Size

Ref.	R1		R2		R3		R4		R5		R6	
	mm	in	mm	in	mm	in	mm	in	mm	in	mm	in
W1*	98	3.9	98	3.9	160	6.3	160	6.3	600	23.6	600	23.6
W2*	98	3.9	98	3.9	160	6.3	160	6.3	600	23.6	600	23.6
H*	712	28.0	812	32.0	983	38.7	1117	44.0	1175	46.3	1175	46.3
a	5.5	0.2	5.5	0.2	6.5	0.25	6.5	0.25	6.5	0.25	9.0	0.35
b	10.0	0.4	10.0	0.4	13.0	0.5	13.0	0.5	14.0	0.55	14.0	0.55
c	5.5	0.2	5.5	0.2	8.0	0.3	8.0	0.3	8.5	0.3	8.5	0.3
d	5.5	0.2	5.5	0.2	6.5	0.25	6.5	0.25	6.5	0.25	9.0	0.35
Mounting Hardware												
	M6	1/4	M6	1/4	M6	1/4	M6	1/4	M8	5/16	M8	5/16

* Measurements are center to center.

NOTE: -088A-2, -114A-2 and -097A-4 NEMA 1 & 12 units are R4 frame base drives in R5 enclosures. R5 enclosure information applies.

TECHNICAL DATA

NEMA 1 & 12, R7...R8 Mounting Dimensions

NEMA 1 and NEMA 12 - Dimensions for each Frame Size			
Ref.	R7 & R8		Top View
	mm	in	
W	806	31.7	
D	659	25.9	
a	675	26.6	
b	474.5	18.7	
c	61	2.4	
d	65.5	2.6	
Mounting Hardware			
	11 mm	13/32	

* Measurements are center to center.

Weights

The following table lists typical maximum weights for each frame size. Variations within each frame size (due to components associated with voltage/current ratings and options) are minor.

En- closure	Weight															
	R1		R2		R3		R4		R5		R6		R7		R8	
	kg	lb.	kg	lb.	kg	lb.	kg	lb.	kg	lb.	kg	lb.	kg	lb.	kg	lb.
NEMA 1	13	28	17	37	45	100	55	121	121	266	163	360	230	506	360	793
NEMA 12	15	33	19	42	47	103	57	125	123	271	166	375	250	551	380	837

NOTE: -088A-2, -114A-2 and -097A-4 NEMA 1 & 12 units are R4 frame base drives in R5 enclosures. R5 enclosure information applies.

TECHNICAL DATA

Outside Dimensions

Outside Dimensions

NEMA 1, R1...R4 Outside Dimensions

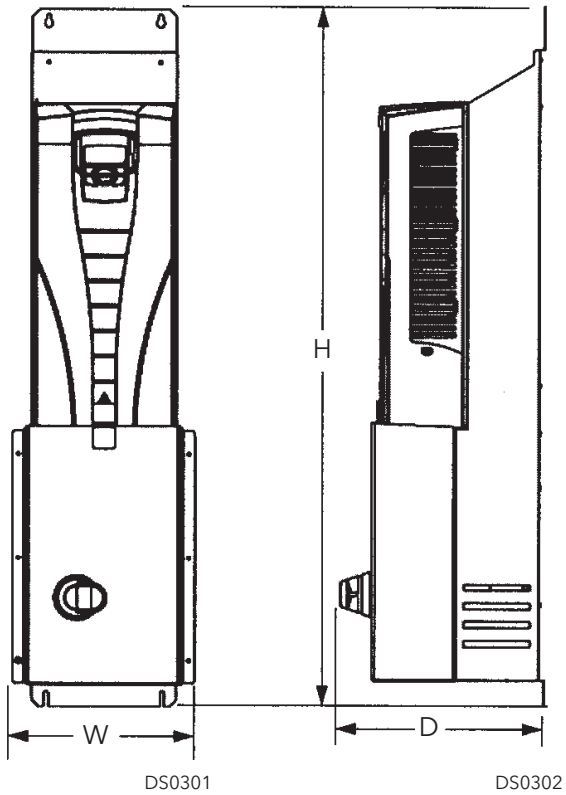

Input Disconnect, NEMA 1, R1...R4								
Dimensions Ref.	R1		R2		R3		R4	
	mm	in	mm	in	mm	in	mm	in
W	198	7.8	198	7.8	260	10.2	260	10.2
H	729	28.7	829	32.6	1013	39.9	1147	45.2
D	283	11.2	295	11.6	304	11.9	332	13.1

NOTE: -088A-2, -114A-2 and -097A-4 NEMA 1 & 12 units are R4 frame base drives in R5 enclosures. R5 enclosure information applies.

TECHNICAL DATA

NEMA 12, R1...R4 Outside Dimensions

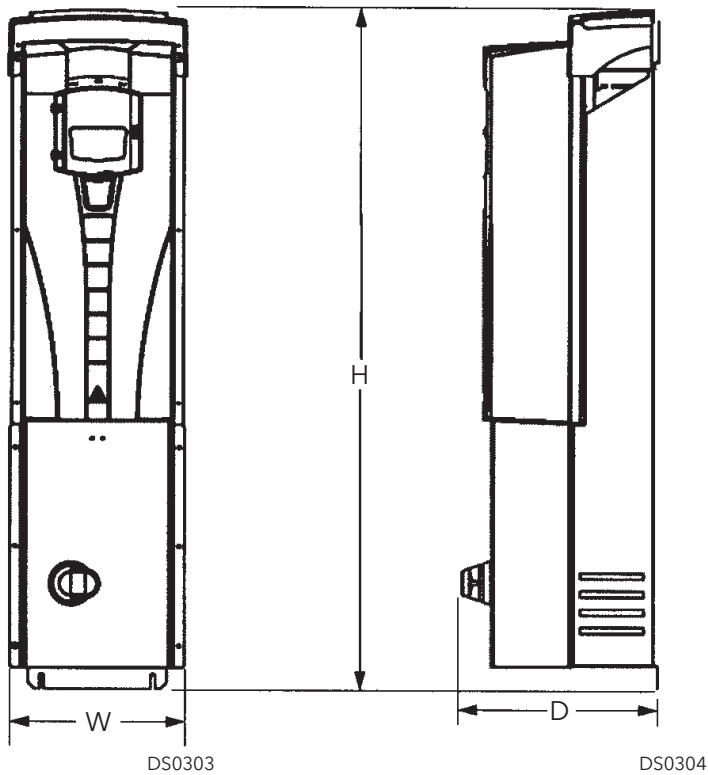

Input Disconnect, NEMA 12, R1...R4								
Dimensions Ref.	R1		R2		R3		R4	
	mm	in	mm	in	mm	in	mm	in
W	222	8.7	222	8.7	267	10.5	267	10.5
H	744	29.3	844	33.2	1030	40.6	1163	45.8
D	283	11.2	295	11.6	304	11.9	332	13.1

NOTE: -088A-2, -114A-2 and -097A-4 NEMA 1 & 12 units are R4 frame base drives in R5 enclosures. R5 enclosure information applies.

TECHNICAL DATA

NEMA 1, R5/R6 Outside Dimensions

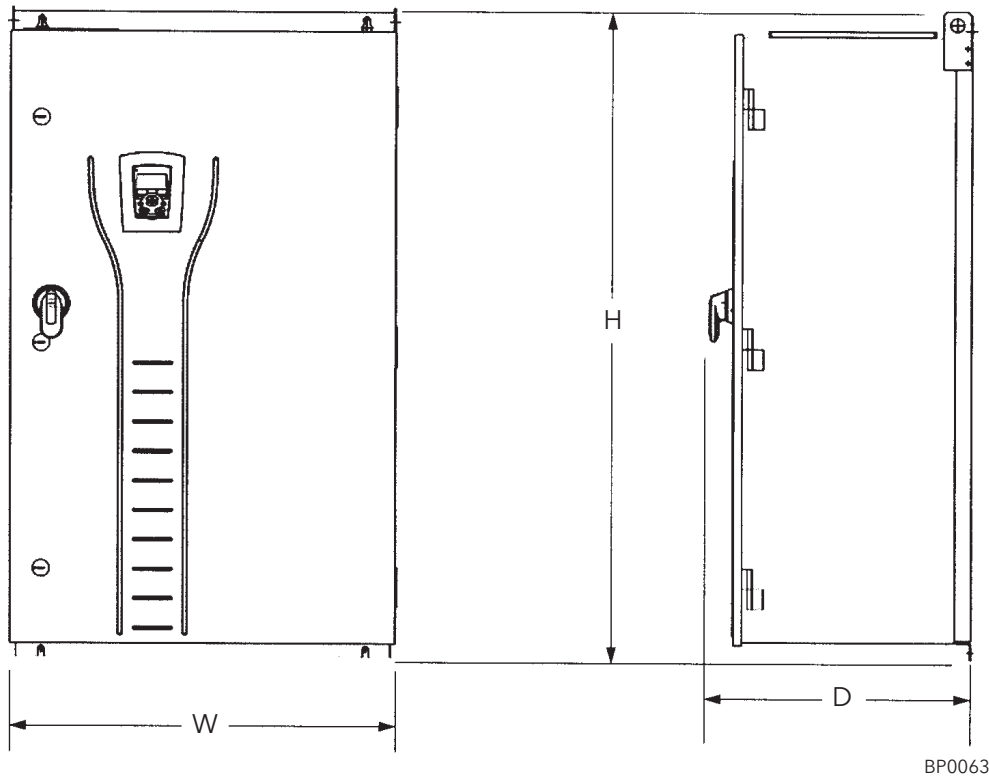

Input Disconnect, NEMA 1, R5/R6				
Dimensions Ref.	R5		R6	
	mm	in	mm	in
W	713	28.1	713	28.1
H	212	47.7	1212	47.7
D	484	19.1	484	19.1

NOTE: -088A-2, -114A-2 and -097A-4 NEMA 1 & 12 units are R4 frame base drives in R5 enclosures. R5 enclosure information applies.

TECHNICAL DATA

NEMA 12, R5/R6 Outside Dimensions

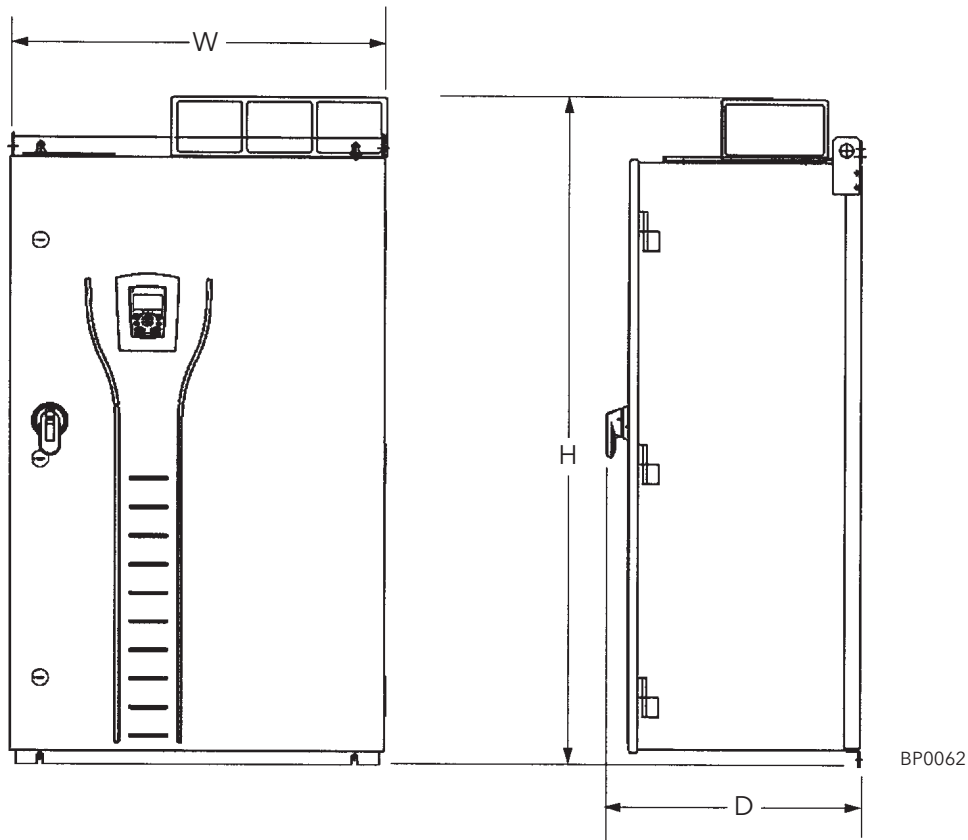

Input Disconnect, NEMA 12, R5/R6				
Dimensions Ref.	R5		R6	
	mm	in	mm	in
W	734	28.9	734	28.9
H	1371	54.0	1371	54.0
D	484	19.1	484	19.1

NOTE: -088A-2, -114A-2 and -097A-4 NEMA 1 & 12 units are R4 frame base drives in R5 enclosures. R5 enclosure information applies.

TECHNICAL DATA

NEMA 1 & 12, R7...R8 Outside Dimensions

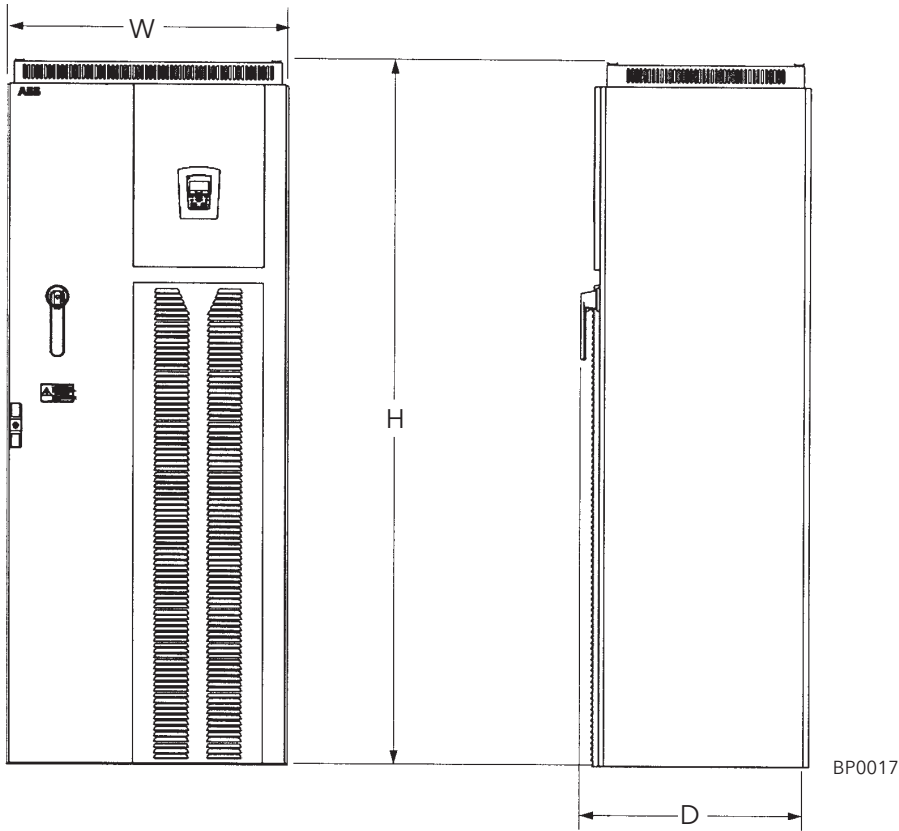

Outside Dimensions by Frame Size					
Enclosure	Ref.	R7		R8	
		mm	in	mm	in
NEMA 1	W	806	31.7	806	31.7
	H	2125	83.7	2125	83.7
	D	659	25.9	659	25.9
NEMA 12	W	806	31.7	806	31.7
	H	2377	93.6	2377	93.6
	D	659	25.9	659	25.9

Additional Free Space Recommendations

In addition to the free space requirements for cooling ("Cooling - R7/R8"), allow:

- 800 mm (31.5 in) in front of R7/R8 enclosures - room for the cabinet door to swing open.
- 305 mm (12 in) above R7/R8, IP54 / UL Type 12 enclosures - room for fan replacement.

TECHNICAL DATA

Applicable Standards

Drive compliance with the following standards is identified by the standards “marks” on the type code label.

Mark	Applicable Standards	
	UL 508C and C22.2 No. 14	UL Standard for Safety, Power Conversion Equipment, second edition and CSA Standard for Industrial Control Equipment
	UL 508A	UL Standard for Safety, Industrial Control Panels
	C22.2 No. 14	CSA Standard for Industrial Control Equipment

Compliance is valid with the following provisions:

- The motor and control cables are chosen as specified in this manual.
- The installation rules of this manual are followed.

INDEX

Refer to the Aquavar CPC User’s Manual (IM167) index for topics not listed here.

air flow.....26	A	dimensions	D
	C	mounting, R1...R627	
cable requirements		mounting, R7...R828	
input power22		outside, NEMA 12, R1...R4.30	
capacitor		outside, NEMA 12, R5...R6.32	
change, maintenance interval.....14		outside, NEMA 1, R1...R4.....29	
connection points		outside, NEMA 1, R5...R6.....31	
floor mounted enclosures12		outside, NEMA 1/NEMA 12, R7...R8.33	
wall mounted enclosures.....11		disconnect	
model code8		diagram4	
control panel		features, functions	
maintenance interval, battery14		drive	
cooling26		fan replacement14	
cover		identification8	
remove6		proper lifting7	
current		weight.....28	
rating code.....8			

INDEX

E	
enclosure protection class code	8
enclosure, NEMA 12	
air filter maintenance	16
fan replacement	15
F	
fan, drive module	
maintenance interval	14
replacement procedure	14
fan, enclosure	
maintenance interval	14
replacement procedure	14
filter, enclosure	
R5/R6 inlet, maintenance interval	14
R5/R6 inlet, maintenance procedure	16
R7/R8, exhaust, maintenance interval	14
R7/R8, exhaust, maintenance procedure	18
R7/R8, inlet, maintenance interval	14
R7/R8, inlet, maintenance procedure	16
free space	
for access, R7/R8	33
for cooling	26
fuses	20
208...240 volt drives	20
380...480 volt drives	21
500...600 volt drives	22
G	
grounding	
requirements	10
H	
heat loss	26
heatsink	
maintenance interval	14
I	
input disconnect	
see disconnect	
input power	
cable/wire requirements	22
fuses	20
installation	
flow chart	6
preparation	7
L	
label	
type code	8
location, mounting	9
M	
maintenance	
drive module fan replacement	14
enclosure fan replacement	14
intervals	14
R5/R6 enclosure inlet filter	16
R7/R8 enclosure exhaust filter	18
R7/R8 enclosure inlet filter	16
manuals, listing	ii
motor	
connection specifications	26
motor cable	
maximum length	26
N	
NEMA 1	
code	8
NEMA 12	
code	8
R	
ratings	19
remove cover	6
S	
safety	3
specifications	
cooling	26
motor connections	26
standards	34
C22.2 No. 14	34
UL 508C	34
T	
terminals	
power, wire sizes	23
type code	8
V	
voltage	
rating code	8
W	
warning	
automatic start up	3
dangerous voltages	3
listing	3
parallel control connections	3
qualified installer	3
weight	
drive	28
wiring	
connection diagrams, floor mounted	12
connection diagrams, wall mounted	11
line input installation	13
overview	11
requirements	10

CENTRIPRO LIMITED WARRANTY

This warranty applies to all Aquavar CPC controllers manufactured by Xylem, Inc.

Any part or parts found to be defective within the warranty period shall be replaced at no charge to the dealer during the warranty period. The warranty period shall exist for a period of twenty-four (24) months from date of installation or thirty (30) months from date of manufacture, whichever period is shorter.

A dealer who believes that a warranty claim exists must contact the authorized CentriPro distributor from whom the controller was purchased and furnish complete details regarding the claim. The distributor is authorized to adjust any warranty claims utilizing the CentriPro Customer Service Department.

The warranty excludes:

- (a) Labor, transportation and related costs incurred by the dealer;
- (b) Reinstallation costs of repaired equipment;
- (c) Reinstallation costs of replacement equipment;
- (d) Consequential damages of any kind; and,
- (e) Reimbursement for loss caused by interruption of service.

For purposes of this warranty, the following terms have these definitions:

- (1) "Distributor" means any individual, partnership, corporation, association, or other legal relationship that stands between CentriPro and the dealer in purchases, consignments or contracts for sale of the subject controllers.
- (2) "Dealer" means any individual, partnership, corporation, association, or other legal relationship which engages in the business of selling or leasing controllers to customers.
- (3) "Customer" means any entity who buys or leases the subject controllers from a dealer. The "customer" may mean an individual, partnership, corporation, limited liability company, association or other legal entity which may engage in any type of business.

THIS WARRANTY EXTENDS TO THE DEALER ONLY.



Xylem, Inc.
2881 East Bayard Street Ext., Suite A
Seneca Falls, NY 13148
Phone: (800) 453-6777
Fax: (888) 322-5877
www.centripro.com

CentriPro and Aquavar are trademarks of Xylem Inc. or one of its subsidiaries.
DUSTLOK® is a registered trademark of Fiberbond Corp.
© 2012 Xylem Inc. IM250 Revision Number 2 February 2013