

Please read and save this Repair Parts Manual. Read this manual and the General Operating Instructions carefully before attempting to assemble, install, operate or maintain the product described. Protect yourself and others by observing all safety information. The Safety Instructions are contained in the General Operating Instructions. Failure to comply with the safety instructions accompanying this product could result in personal injury and/or property damage! Retain instructions for future reference. AMT reserves the right to discontinue any model or change specifications at any time without incurring any obligation.

©2017 AMT Pump Company, A Subsidiary of The Gorman-Rupp Company, All Rights Reserved.

Periodic maintenance and inspection is required on all pumps to ensure proper operation. Unit must be clear of debris and sediment. Inspect for leaks and loose bolts. Failure to do so voids warranty.



IPT Submersible Pumps

Refer to pump manual 1808-636-00 for General Operating and Safety Instructions.

INSTALLATION & OPERATING INSTRUCTIONS SUBMERSIBLE PUMPS

START-UP DESCRIPTION: Check that the voltage of the power supply is the same as that marked on the pump. When permanently installing the pump, in a sump for example, make sure that the holding capacity of the sump is commensurate with the capacity of the pump. If the sump is too small, the pump will stop and start too often resulting in damage to the pump. Recommended maximum start-ups per hour is 6. If used with a hose, check that no kinks or restrictions are present.

ELECTRICAL CONNECTION: Check that the power is off and the line is disconnected before working on any pump.

▲ WARNING

Always disconnect power before undertaking any work on a pump, cable, control box or accessories.

HANDLING: Never lift a pump by its power cord. Always lift the pump by its handle or attach a rope or wire cable to the handle or lifting rings. Lifting by the power cord can cause dangerous electrical shorts or pump failure.

PLACING THE PUMP: Never place the pump on a loose or soft bottom. It could sink in and fill the pump housing with material, blocking water flow to the impeller. Install the pump on a solid bottom or hang the pump by a wire. If the pump is hung by a wire, it will have to be restricted from twisting during start-up. This can be done by securing the pump to one side of the sump. Stop and starts not to exceed 6 times per hour, make sure to size the pump according to sump size and water inflow.

LIQUID TEMPERATURE: The temperature of the water must not exceed 120°F.

SUBMERSION DEPTH: The maximum depth is 33 ft. (10m) or the length of the factory installed electrical cable, whichever is less. If the initial start depth in water is less than 3 inches, the pump must be primed.

COLD WEATHER: The pump will not freeze as long as it is submerged and in operation. If it is removed from the liquid, empty the pump, clean it and dry it. Then store it in a place where the temperature is not below 32°F (0°C). If the pump has been exposed to freezing temperatures, let it thaw slowly before it is started again. Never thaw using flame or similar methods as O-rings and other materials may be damaged.

TROUBLES AND THEIR CURES

GENERAL

1. Not starting:
 - a. Check the power supply, testing both voltage and amps.

- b. Check any fuses and switches.
- c. Check the cable, contactor and all connections. Test for continuity. Also test the stator for turn fault and insulation to ground.
- d. Make sure that the impeller is clean and rotating freely.

IMPORTANT: When trouble shooting; always follow local, state and federal regulations regarding procedures and safety. If the pump still does not start, please contact the closest available recommended repair shop.

2. Low Capacity or Low Head: The cause can be clogged passages, for example the strainer, a damaged or worn impeller or pump housing, broken pipes, damaged or kinked hoses or discharge pipe or too long or too narrow a hose.
3. Water in the stator housing: If water is found in the stator housing, the pump must be dismantled for a complete overhaul and the stator dried out. Probable causes: Damaged worn shaft seals or bad O-rings (Check oil housing for water contamination). Change seals. Damaged cable entrance (change).
4. Water in the oil housing: Problem can be worn or damaged oil lip seal and mechanical seals - change if needed; or leaking inspection plug or oil house cover - change elastomers.

REPAIR AND MAINTENANCE INSTRUCTIONS

Follow the instructions on all tags, label and decals attached to the pump:

▲ WARNING

Before attempting to open or service the pump:

1. Familiarize yourself with this manual.
2. Unplug the pump power cable to ensure that the pump will remain inoperative.
3. Allow the pump to completely cool, if overheated.
4. Do not attempt to lift the pump by the power cable or piping. Attach proper lifting equipment to the handle on the pump.
 - a. Select a suitable location, preferably indoors, to perform the degree of maintenance required.

If the motor housing is to be opened, the work must be done in a clean, well-equipped shop. All maintenance functions must be done by qualified personnel.

▲ WARNING

Obtain the services of a qualified electrician to service the electrical components of this pump.

Complete disassembly procedures for the pump motor **are not** included in this manual. Instructions are provided only for replacement of pump end components, the pump power cable and capacitor. If the pump fails to run and motor problems are suspected, contact the factory for motor service.

IPT Submersible Pumps

PUMP END DISASSEMBLY:

1. To remove the strainer screen, lay the pump on its side, disengage the hardware and remove the strainer. If the impeller is clogged, the debris can usually be removed without further disassembly.
2. Remove the machine screws and separate the suction cover and suction cover O-ring. Immobilize the shaft by inserting a large flat blade screwdriver into the slot in the end of the shaft. Strike the impeller in a counterclockwise direction with a soft-faced mallet or wood block and hammer until loose and remove.
3. **SEAL REMOVAL:** Remove the oil cavity drain screw and O-ring and drain the oil from the seal cavity. Remove the machine screws and use a pair of flat head screwdrivers to pry the oil chamber cover and oil seal off the shaft as a unit. Remove the oil chamber gasket. Invert the oil chamber cover and remove the lower seal stationary element and seat from the cover. With the oil chamber cover inverted, press the oil seal out of the oil chamber cover from the back side. Lubricate the seal area of the rotor shaft, and slide the rotating portion of both the lower and upper seal assemblies off the shaft.
To remove the stationary portion of the upper seal assembly, slide two stiff wires with hooked ends along the shaft and hook the stationary seat and element from the back side. Pull the stationary portion of the seal from the bore of oil chamber. Stuff a clean tissue into the stationary seal seat bore or wrap a small rag around the shaft to prevent contamination of the motor cavity. If no further disassembly is required, proceed with the appropriate **pump end reassembly** procedures for your specific pump.
4. **POWER CABLE REMOVAL:** With the strainer and suction cover removed, remove the discharge flange assembly. Remove the handle. Remove the power cable clip from the outer pump casing. Remove the hardware securing the cable gland to the pump casing. Pull the outer pump casing up off the motor, feeding the cable gland down through the hole in the casing as the casing is removed. Remove the holding rods and lock washers securing the motor top cover to the stator casing. Raise the motor top cover to expose the power cable leads and capacitor. Remove the connectors from the power cable leads and remove the power cable and inner power cable gland gasket. It is not necessary to remove the ground wire unless replacement is required. To remove the overload and the motor cover grommet, disengage the machine screws. Use caution not to allow the motor leads for the capacitor to slip down into the motor. If the capacitor requires replacement, remove the shrink tubing (not shown) and separate the capacitor leads from the stator leads.
5. **POWER CABLE INSTALLATION:**

NOTE: Reuse of old O-rings or gaskets may result in premature leakage or reduced pump performance. It is strongly recommended that new O-rings and gaskets be used during reassembly (see the parts lists for the O-ring/ gasket kit part number).

If the capacitor was removed, feed the motor leads for the capacitor and overload through the new grommet and install the grommet in the hole in the upper motor cover. Connect the wires for the overload to those in the motor, and secure the overload with the machine screws. Slide a piece of heat shrink tubing (not shown) over the capacitor leads. Connect the leads on the capacitor to the capacitor leads from the motor. Slide the heat shrink tubing down over the connections and use a heat gun to shrink the tubing and seal the connections. If the ground wire was removed, secure a new wire to the motor top cover with the machine screw. Slide the gland end of the power cable down through the outer pump casing. Install a new outer power cable gland gasket against the power cable gland. Push the power cable leads through a

new inner power cable gland gasket and down through the hole in the pump top cover. Connect the ground wire and stator leads to the power cable leads with the wire connectors.

▲ WARNING

THE GREEN GROUND LEAD ON THE POWER CABLE MUST BE CONNECTED TO THE GREEN LEAD GROUNDED TO THE MOTOR TOP COVER FAILURE TO GROUND THE POWER CABLE OR MISS WIRING OF THE GROUND LEAD COULD DAMAGE THE PUMP AND/OR CAUSE SERIOUS INJURY OR DEATH TO PERSONNEL.

Carefully fold the capacitor and power cable leads under the pump top cover and secure the cover to the stator casing with the holding rods and lock washers. Make sure the cable leads are not pinched under the pump top cover. Position the inner power cable gland gasket over the flange on the motor top cover. Slide the outer pump casing down over the motor and over the motor top cover flange. Secure the pump casing to the motor top cover with one of the cap screws and lock washers. Carefully compress the power cable leads into the motor top cover and secure the power cable gland to the cover with the machine screws. Install the cable clip, flange assembly and handle.

6. **PUMP END ASSEMBLY:** It is strongly recommended that all seals and gaskets be replaced any time the pump is disassembled. Thoroughly clean all reusable parts. Remove all O-rings and gaskets, and clean the sealing surfaces of dirt or gasket material. Be careful not to scratch gasket surfaces. Inspect the rotor shaft for damaged threads, scoring, or nicks.

Remove nicks and burrs with a fine file or emery cloth to restore original contours. The shaft seal assembly should not be reused because wear patterns on the finished faces cannot be realigned during reassembly. This could result in premature failure. If any components are worn, replace the complete seal; never mix old and new seal parts. Handle a new seal with extreme care to prevent damage. Be careful not to contaminate the precision finished faces. Clean the rotor shaft and seal cavity area. Be sure the area is dry and free of lint and dirt. Check the seal bore for burrs or nicks that might prevent a good seal. Apply a light coating of oil to the bore.

When pressing seal components onto the shaft, use hand pressure only. Ensure that the upper stationary element is sub assembled into the stationary cup seat. Position this subassembly Page 7 Document #27474 46-904 Rev. 03/03 in the oil chamber bore with the sealing face up, and cover the seal face with a clean, lint-free cloth. Use your thumbs to press the assembly into the bore. Apply equal pressure on opposite sides until the seat contacts the bore shoulder. Remove the tissue and inspect the seal face to ensure that it is clean and dry. If cleaning is necessary, use a clean lint-free cloth to wipe lightly in a concentric pattern. Be certain the seal face of the upper rotating element is free of grit or surface damage and that it is clean and dry. Apply a light coating of oil to the seal seating surface on the shaft and the I.D. of the bellows. Apply a drop of oil to the seal face. Slide the rotating portion of the upper seal assembly onto the lubricated shaft. Apply firm, steady pressure on the seal retainer until the seal slides onto the shaft and the upper seal faces contact.

Repeat the above procedure for the rotating portion of the lower seal assembly, making sure to position the lower seal back-to-back against the upper seal. Position the oil chamber cover with the motor side up. Ensure that the lower seal stationary element is sub assembled in the stationary cup seat. Position this subassembly in the cover bore with the sealing face up, and cover the seal face with a clean,

IPT Submersible Pumps

lint-free cloth. Use your thumbs to press the assembly into the bore. Apply a drop of oil to the lower seal stationary face. Install the oil chamber cover gasket. Carefully position the oil chamber cover over the shaft so the lower seal faces contact. Install the machine screws and tighten them in an alternating pattern until the seal springs are compressed and the cover seats tightly against the gasket. Fill the seal chamber with oil to cover the seals, but do not completely fill the chamber. There must be enough air in the chamber to allow for expansion as the oil heats. Refer to the **Lubrication Specifications** at the end of this section for the correct lubricant. Reinstall the oil cavity drain screw and O-ring. Lubricate the lip of the oil seal and place the seal in the oil chamber cover with the lip positioned as shown in the seal detail, Figure 1. Press the seal into the oil chamber cover until fully seated.

7. **IMPELLER INSTALLATION:** Lubricate the O.D. of the shaft

sleeve. Slide the sleeve over the shaft and through the lip seal until fully seated against the shaft shoulder. Be careful not to damage the lip seal. Screw the impeller onto the shaft until it is fully seated. Insert a large flat-blade screwdriver into the slot in the end of the shaft. Tighten the impeller on the shaft by tapping it with a hammer and wood block or a soft-faced mallet. Install the suction cover O-ring and impeller housing/suction cover and position the strainer screen against the impeller housing/suction cover, and secure.

8. **LUBRICATION SPECIFICATIONS:** When shipped from the factory, the pump seal cavity was fully lubricated with Shell Turbo-T68 oil. Use only Shell Turbo-T68 or Gulf Harmony HVI AW 26 oil for repair. Quantities for each pump are as follows: Seal Cavity: Cover seal but do not completely fill chamber.
Motor: Does not require lubrication

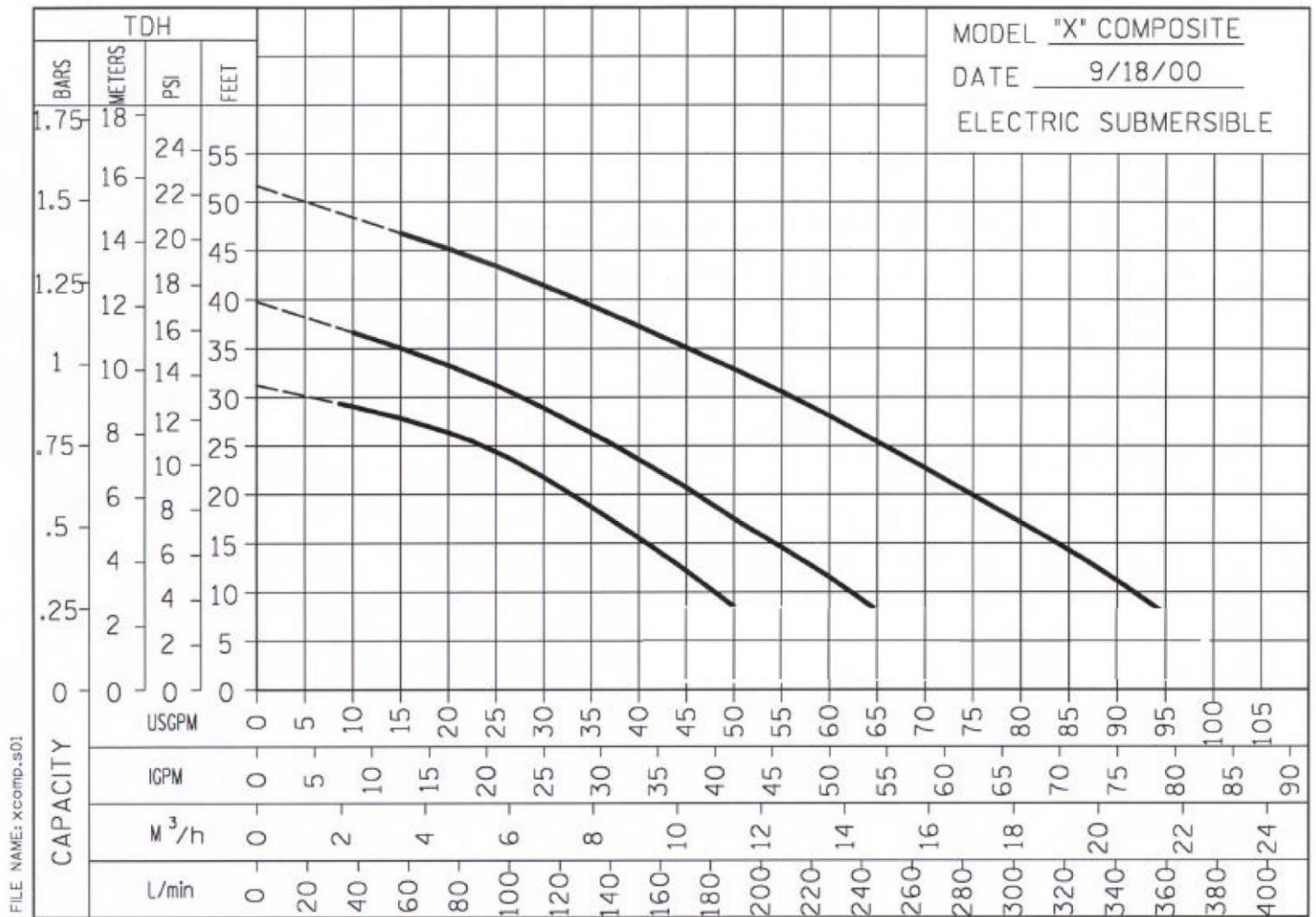

Figure 1

For Repair Parts contact dealer where pump was purchased.

Please provide following information:

- Model Number
- Serial Number (if any)
- Part description and number as shown in parts list

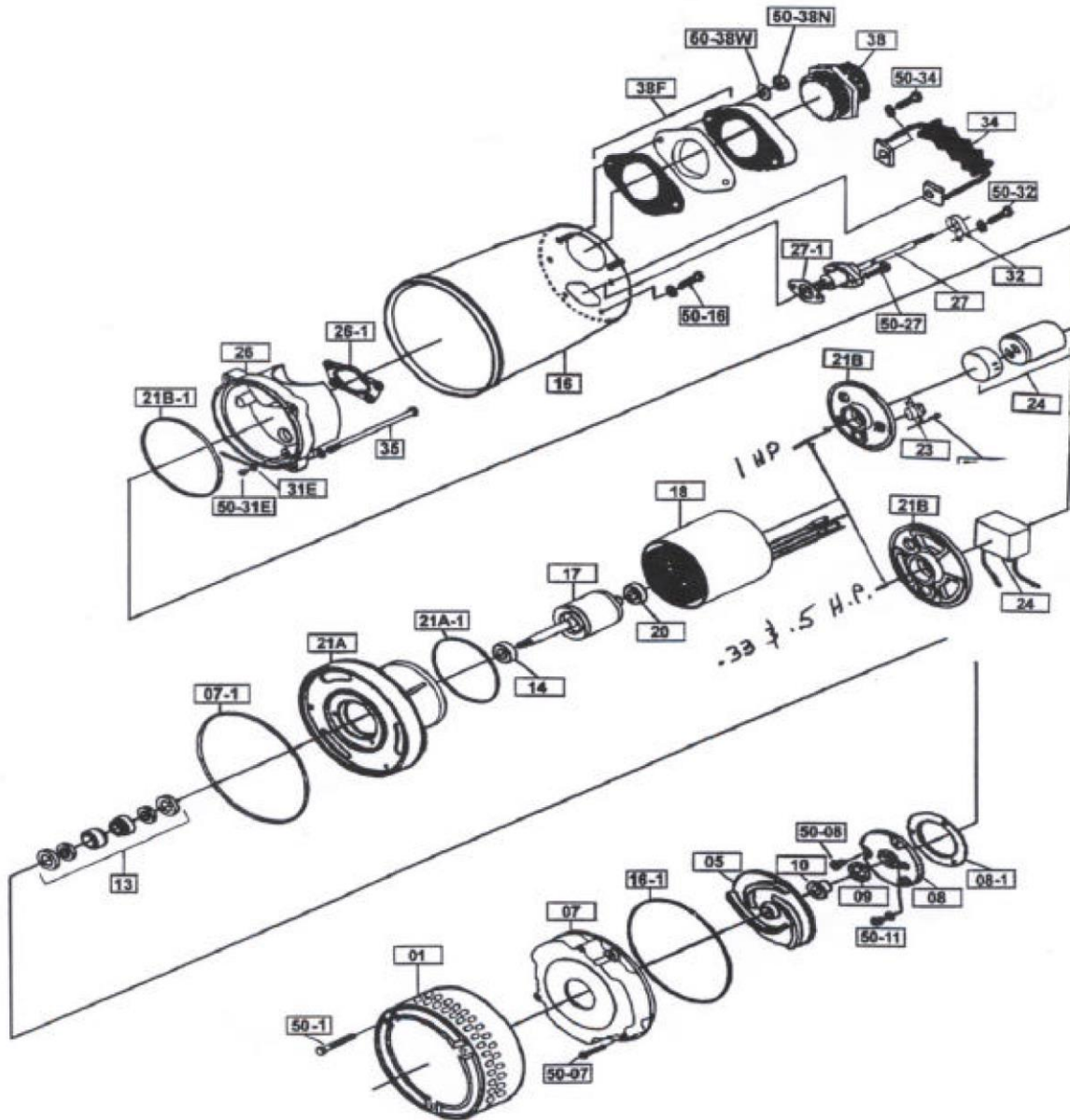

Figure 2 – Repair Parts Illustration

Repair Parts List

Ref. No.	Description	Part Number for Models:		Qty.
		2XH5	2X11	
01	Strainer w/ Bottom Plate	26816-617	26816-517	1
05	Impeller	26816-002	26816-502	1
07	Impeller Housing/Suction Cover	26816-601	26816-501	1
07-1	O-Ring	†	†	1
08	Oil Chamber Cover	N/A	N/A	-
08-1	Gasket	†	†	1
09	Lip Seal - Buna N	26816-007	26816-507	1
10	Shaft Sleeve	26816-339	26816-539	1
13	Mechanical Shaft Seal	26816-003	26816-503	1
14	Ball Bearing (lower)	*	*	1
16	Casing Cover	26816-611	26816-511	1
16-1	O-Ring	†	†	1
17	Rotor	N/A	N/A	-
18	Stator	N/A	N/A	-
20	Ball Bearing (upper)	*	*	1
21A	Oil Chamber Cover	N/A	N/A	-
21A-1	O-Ring	†	†	1
21B	Motor Cover (upper)	N/A	N/A	-
21B-1	O-Ring	†	†	1
23	Overload	N/A	N/A	-
24	Capacitor	N/A	N/A	-
26	Pump Cover (top)	26816-614	26816-514	1
26-1	Gasket	†	†	1
27	Power Cable w/ Gland	26816-015	26816-215	1
27-1	Gasket	†	†	1
31E	Ground Wire w/ Terminal	N/A	N/A	-
32	Clip	26816-020	26816-020	1
34	Handle	26816-521	26816-521	1
35	Rod Bolt	N/A	N/A	-
38	Pipe Nipple	26816-022	26816-022	1
38-F	Discharge Flange Assembly	202568	202568	1
50-01	Screw	*	*	3
50-07	Screw	*	*	3
50-08	Screw	*	*	3
50-11	Screw w/ O-Ring	†	†	1
50-16	Screw	*	*	1
50-27	Screw	*	*	2
50-31E	Screw	*	*	1
50-32	Screw	*	*	1
50-34	Screw	*	*	2
50-38N	Nut	*	*	2
50-38W	Washer	*	*	2
†	Gasket Kit - Buna N (includes Ref. Nos. 07-1, 08-1, 16-1, 21A-1, 21B-1, 26-1, 27-1, and 50-11)	26816-616	2686-516	1
	Float Switch, Piggyback	55-930	55-950	1
(*)	Standard Hardware Item, Available Locally			

Order Online: www.PumpCatalog.com

Installation of Piggyback Float Switch

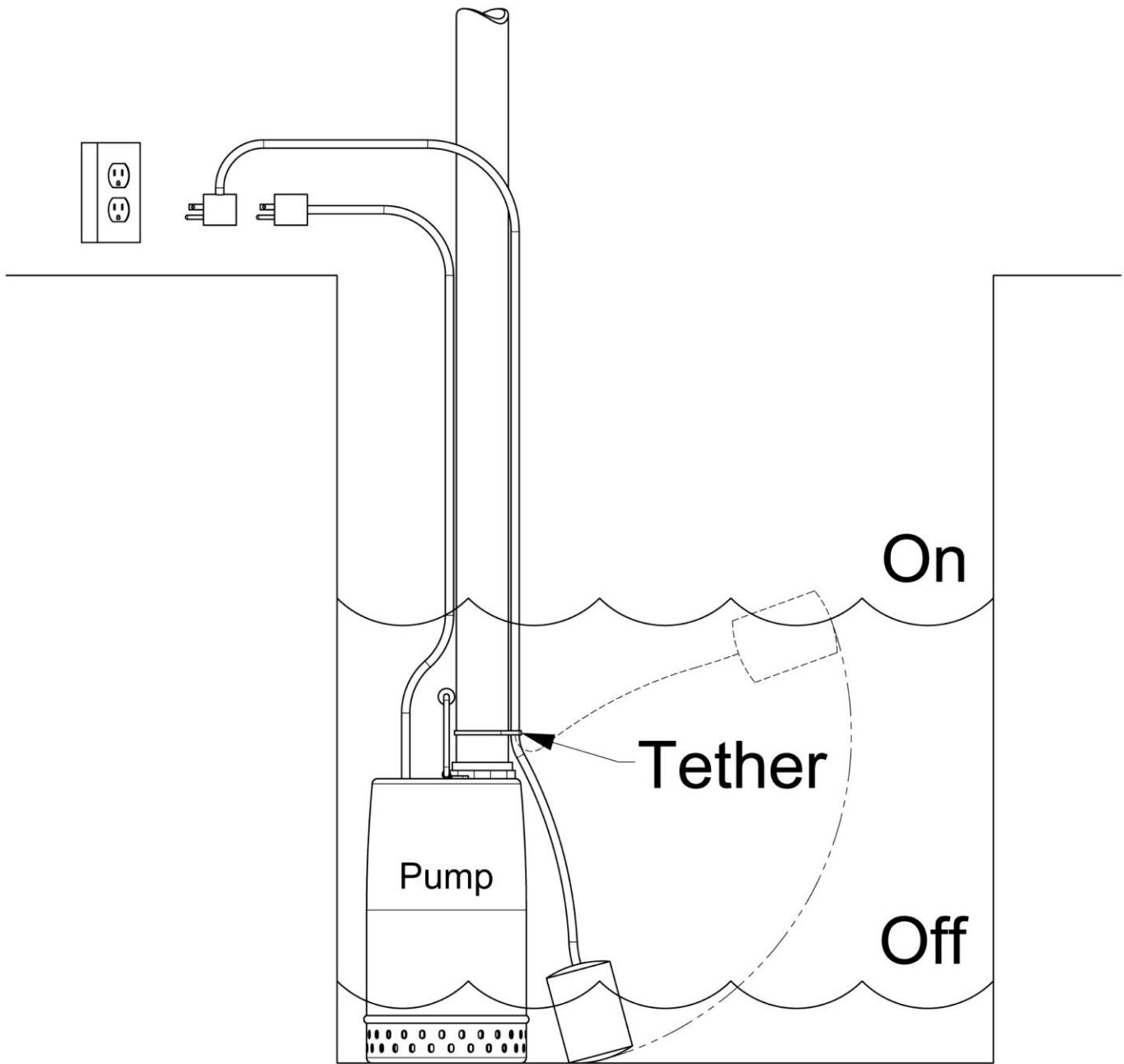
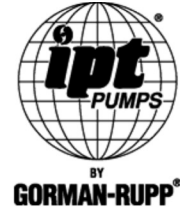

Figure 3 – Float Switch, Piggyback



AMT Pump Company
(herein "AMT")
400 Spring Street
Royersford, PA 19468
Phone: (610) 948-3800
Fax: (610) 948-5300
www.amtpump.com



General Information

SALES POLICY: AMT products are sold through our established Distributors. We do not sell direct to the consumer or organization not entitled to trade recognition. Therefore, possession of our catalogs and/or price list(s) does not infer an offer to sell.

MINIMUM ORDER: We appreciate your order, however, all orders are subject to a minimum \$35.00 net invoice charge (excluding freight). This applies to all pump and parts purchase orders.

PRICES: Prices are subject to change without notice. All orders accepted are subject to prices in effect at time of shipment.

PAYMENT TERMS: Terms, upon establishment of credit, are Net 30 days. Past due accounts may be subject to a service charge of 1.5% per month. Domestic or assignable letter of credit is required for all export trade.

PAST DUE ACCOUNTS: AMT reserves the right to withhold open account shipments on any past due account. Invoices are considered past due after thirty (30) days. In the interest of sound business, all orders are subject to approval of the Credit Department.

SHIPPING INSTRUCTIONS: All shipments will be made F.O.B. the factory. Where instructions for shipment do not appear on the order, the shipment will be made according to our best judgment. Full risk of loss (including transportation delays and losses) shall pass to the customer upon delivery of the products to the carrier at the F.O.B. point. When loss or delay occurs, primary responsibility for tracing rests with the customer. When there is LOSS or APPARENT VISIBLE DAMAGE to a shipment, when tendered for delivery, **DO NOT** give the carrier a clear receipt. Note such damage on the carrier's delivery receipt and **HAVE THE DRIVER SIGN THE RECEIPT.**

PRODUCT REVISIONS: AMT reserves the right to discontinue, change or improve its products or any portions thereof without being obligated to provide such a change or improvement for units sold and/or shipped prior to such a change or improvement.

12 Month Limited Warranty

EXTENT AND DURATION OF LIMITED WARRANTY

Coverage: AMT Pump Company (herein "AMT") or IPT Pumps by Gorman-Rupp (herein "IPT") or Gorman-Rupp Industries Division of The Gorman-Rupp Company, Patterson, or the Gorman-Rupp Company (herein referred to as "G-R Unit") each individually warrants that its products and parts shall be free from defects in material and workmanship for twelve (12) months from the date of purchase by the original end user when installation is made and maintenance is performed in accordance with G-R Unit's recommendations. Wear and tear resulting from use and items normally consumed in use are not covered.

EXCEPTIONS

(A) This Limited Warranty shall not apply to mechanical seals in AMT or IPT pumps and the following products and parts: engines, motors, trade accessories and all other products, components, parts and materials not manufactured by the G-R Units. These items may, however, be covered by the warranties of their respective manufacturers. (B) This warranty does not extend to or apply to any unit which has been repaired or altered at any place other than by a G-R Unit, or by persons not expressly approved by a G-R Unit to make repairs or alterations, nor to any unit the serial number, model number or identification of which has been removed, defaced or altered. (C) This warranty does not extend to any product manufactured by a G-R Unit, which has been subjected to mis-use, neglect, accident, improper installation, or use in violation of instructions furnished by a G-R Unit. (D) Pump Kits: This warranty does not extend to any product sold by a G-R Unit unassembled as a Pump Kit. Pump Kits are warranted against defects in material and workmanship for 60 days from the date of shipment from a G-R Unit. Any Pump Kit parts deemed defective by a G-R Unit will be replaced free of charge within 60 days of shipment. Pump Kits are not returnable for credit.

LIMITATIONS

THE G-R UNITS' SOLE AND EXCLUSIVE WARRANTY WITH RESPECT TO THEIR PRODUCTS AND PARTS IS THIS LIMITED WARRANTY. THIS LIMITED WARRANTY IS IN LIEU OF ALL OTHER EXPRESS AND/OR IMPLIED WARRANTIES, INCLUDING IMPLIED WARRANTIES OF MERCHANTABILITY AND FITNESS FOR PARTICULAR PURPOSE.

EXCLUSIVE REMEDY AND DAMAGES

The sole and exclusive remedy for breach of this Warranty by a G-R Unit and the entire extent of its liability for such breach or for damages arising from the use of the products and parts covered under this Limited Warranty, shall be as follows:

LEAD TIME: Products designated "Quick Ship Product", also referred to as "QSP" will normally be shipped within 24 hours of receipt of a non-cancellable purchase order. Only limited quantities of "QSP" pumps are available.

STANDARD LEAD TIME: Lead time is two weeks for all non "QSP" product. AMT reserves the right to revise lead times as required due to availability of materials and all other causes beyond our control.

VIP SHIPMENT: Select AMT and IPT branded pumps are available for next day shipment for non-QSP (Quick Ship Products) items and subjected to a specific model surcharge per unit noted in the respective price book. Requires calling for availability, confirmation and a non-cancellable purchase order or credit card payment prior to shipment. The expedited shipping charges are an additional cost added separately from the VIP charges per item. AMT reserves the right to revise lead times as required due to availability of materials and all other causes beyond our control. QSP quantities are limited as determined by AMT.

ALL purchase orders must be submitted via hard copy sent to AMT customer service department by fax, EDI or e-mail.

RETURN GOODS POLICY: Goods shall not be returned without a return goods authorization number (RGA) issued by AMT customer service. The RGA number must be listed on the packing list. Only current model and part numbers with a valid date code may be returned (within one year from date of purchase). **A 20% restocking and packaging charge will apply to all returns. All shipping charges must be pre-paid. No exceptions.**

ORDER CHANGES BY CUSTOMER: Orders in process may not be changed except with written consent and may be subject to special charges.

- 1. Repair or Replacement:** If inspection shows that any G-R Unit product or part covered under this Limited Warranty is defective in materials or workmanship, the G-R Unit shall repair or replace the defective or non-conforming product or part without charge, whichever the G-R Unit chooses. You must have properly maintained and used the product or part claimed to be defective in accordance with the maintenance schedule or manual, which comes with the product. No allowance will be made for labor, installation, removal, transportation or other charges incurred by you in connection with such repair or replacement.
- 2. To obtain the above remedy:**
 - A.** Immediately notify the G-R Unit upon discovery of the claimed defect in materials or workmanship and provide the serial number or date code of the product and/or part(s) or provide the G-R Unit with the invoice or bill of sale referencing the product by no later than the expiration date of the warranty period.
 - B.** The G-R Unit will advise whether inspection will be necessary and how whether repair or replacement will be made. If inspection by the G-R Unit is necessary, the pump or defective part must be sent freight pre-paid to the G-R Unit. Return shipment will be F.O.B. the G-R Unit's plant.
 - C. Return Goods Authorization Requirement:** No product will be accepted for return or replacement without the prior written authorization of the G-R Unit. Upon such authorization, and in accordance with instructions from the G-R Unit, the product will be returned to the G-R Unit, shipping charges prepaid by the Buyer.
- 3. Damages:** The G-R Unit's liability for damages for breach of this Limited Warranty shall not exceed the amount of the purchase price of the product or part(s) in respect to which Such damages are claimed. **IN NO EVENT SHALL THE G-R UNITS BE LIABLE FOR INCIDENTAL, CONSEQUENTIAL OR SPECIAL DAMAGES FOR BREACH OF THIS LIMITED WARRANTY.**

Some states do not allow the exclusion or limitation of incidental or consequential damages, so the above limitation or exclusion may not apply to you. This Limited Warranty gives you specific legal rights, and you may also have other rights, which vary from state to state.



A Gorman-Rupp Company

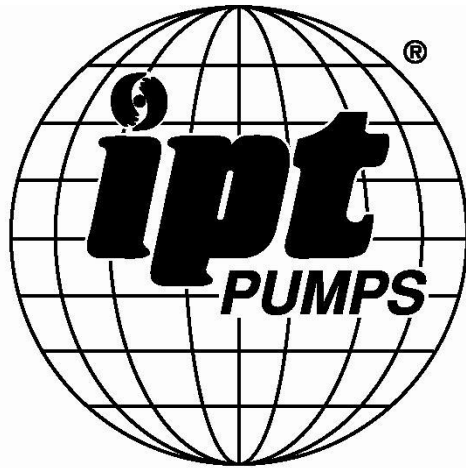

BY
GORMAN-RUPP®

www.amtpump.com

Order Online: www.PumpCatalog.com