

2" AND 3" 'S' SERIES SELF-PRIMING COMMERCIAL DUTY PUMP

BULLETIN
PP-637C
March 2024



SE3SL E6VCP

Pacer Pump Features:

- Corrosion resistant glass reinforced polyester.
- EPDM elastomers are standard, Buna-N and Viton® are optional.
- Maximum flow to 280 U.S. GPM.
- Maximum TDH to 120 feet.
- Suction lift to 25 feet.
- 2 or 3" NPT ports, BSP optional.
- Double flush volute with built-in check valve.
- Lightweight and portable with molded carry handle and available with optional roll cage.
- Shaft seal is stainless steel with carbon and ceramic faces, EPDM fitted.
- Electric Start Options Available

PERFORMANCE CURVE

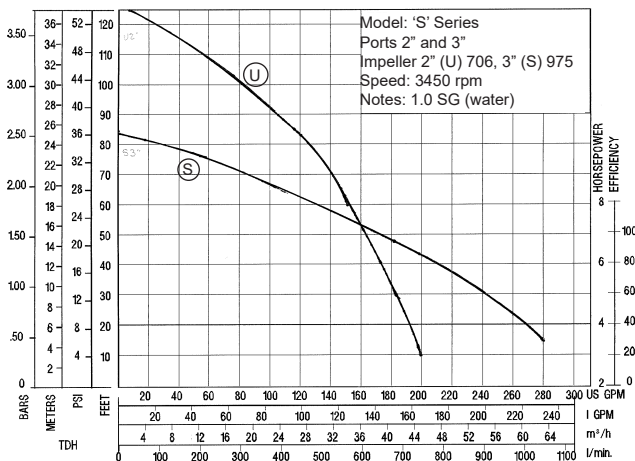

Vanguard Engine Features:

- Briggs & Stratton commercial duty 6.5 hp engine.
- 3 year warranty on engine through manufacturer.
- Compact overhead valve design.
- Dual ball bearings.
- Cast iron cylinder sleeve.
- High capacity air cleaner.
- Metal fuel tank with 4 liter capacity.
- Run Sense low oil system.
- Mechanical governor.
- Fuel shut-off valve with sediment bowl.
- Simultaneous fuel/ignition shut-off protects the engine from oil/fuel dilution during transport.
- Electric start option available.



PUMP SPECIFICATIONS

CURVE	MODEL	PORT SIZE	MAX. FLOW	MAX. TDH	ENGINE	WEIGHT
U	SE2UL E6VCP	2"	200 GPM	120 ft.	Briggs & Stratton Vanguard	55 lbs
S	SE3SL E6VCP	3"	280 GPM	83 ft.	Briggs & Stratton Vanguard	55 lbs.



Division of ASM Industries, Inc.

41 Industrial Circle
Lancaster PA 17601
email: sales@pacerpumps.com
www.pacerpumps.com

Phone: 717-925-8240
Toll Free: 800-233-3861
FAX: 717-925-8242



2" AND 3" 'S' SERIES SELF-PRIMING COMMERCIAL DUTY PUMP



CARING FOR PACER PUMPS:

When handling agricultural fertilizer and chemicals, flush pump with fresh clean water immediately after use. Before storing pump, **flush** with fresh clean water and **drain** completely.

EPDM rubber components **are not compatible** with petroleum products. **Do not** use petroleum products when preparing pump for storage.



Extra engine protection with special shaft gasket helps keep liquid from entering engine in the event of seal failure. Always replace a dripping seal before additional damage occurs.

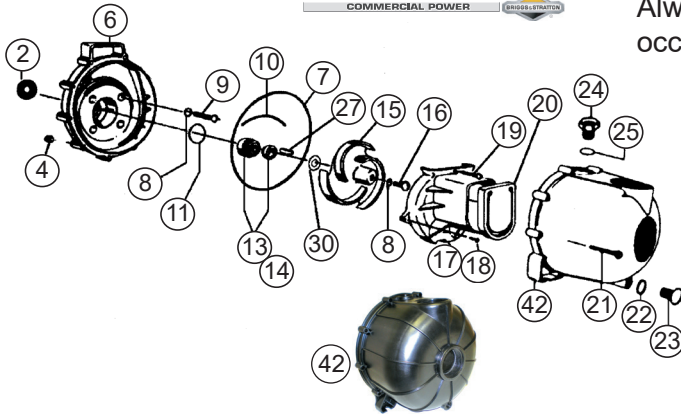

- Housing, volute and impeller: glass-reinforced polyester
- Rubber parts: EPDM
- Shaft seal: Stainless steel with carbon and ceramic faces, EPDM fitted.
- Hardware: Internal and external stainless steel fasteners
- Working pressure: To 52 PSI
- Flow: To 280 GPM

PARTS LIST FOR MODEL NUMBERS SE2UL E6VCP AND SE3SL E6VCP

REF. NO.	DESCRIPTION	QTY./PUMP	SE2UL E6VCP	SE3SL E6VCP
2	Engine protection gasket	1	P-58-0935 72	P-58-0935 72
4	Body nut (as required)	10	P-58-0721 10	P-58-0721 10
6	Bracket	1	P-58-0703 30B	P-58-0703 30B
7	"O"-ring, body	1	P-58-0719 72	P-58-0719 72
8	"O"-ring, screw	5	P-58-0717 72	P-58-0717 72
9	Screw, Bracket	4	P-58-0715 10	P-58-0715 10
10	"O"-ring segment	1	P-58-0754 72	P-58-0754 72
11, 13, & 14	Shaft seal & "O"-ring	1	P-58-0714 12	P-58-0714 12
15	Impeller	1	P-58-0706 30	P-58-0975 30
16	Screw, impeller	1	P-58-0716 10	P-58-0716 10
17	Volute	1	P-58-0702 30	P-58-0977 30
18	Screw, side volute	As required	P-58-0725 10	P-58-0725 10
19	Screw, top volute	As required	P-58-0771 10	P-58-0997 10
20	Check valve	1	P-58-0705 72	P-58-0705 72
21	Screw, body 2-7/16" (old)	10	P-58-0720 10	P-58-0720 10
	Screw, body 2" (new)	10	P-58-1206 10	P-58-1206 10
22	"O"-ring, drain plug	1	P-58-1009 72	P-58-1009 72
23	Drain plug	1	P-58-0723 30	P-58-0723 30
24	Filler plug	1	P-58-0722 30B	P-58-0722 30B
25	"O"-ring, filler plug	1	P-58-0765 72	P-58-0765 72
27	Key	1	P-58-0718	P-58-0718
30	Shim	As required	P-58-0778 11 (.006)	P-58-0778 11 (.006)
		As required	P-58-0778 12 (.015)	P-58-0778 12 (.015)
		As required	P-58-0778 13 (.030)	P-58-0778 13 (.030)
42	Body, 2" or 3" NPT	1	P-58-1002 30B	P-58-0755 30B