

SyF10

BY DEMING®

 PumpCatalog.com

Questions? Call 1-800-810-1053



NEW HIGH EFFICIENCY SOLIDS HANDLING SOLUTION

Introducing SyFlo, the latest high-efficiency solids handling solution designed for superior performance and reliability. Engineered with innovative scroll and vortex impellers, SyFlo delivers exceptional clog resistance and hydraulic efficiency, reducing energy consumption and operating costs.

FEATURES AND BENEFITS

- **High efficiency air-filled motors** reduce installation and operating costs
- Large performance coverage with minimal models leads to **easy selection** of the right pump
- **Easily retrofit into installations** with accessory compatibility and small footprint
- **New side entry cord** provides optimal heat transfer, allowing motor to run continuously while partially submerged
- **One piece motor housing** eliminates joints and improves reliability
- **Easy installation** with a stainless steel quick disconnect powder cord
- Improved **high efficiency hydraulics** with excellent clog resistance

- 1 Large Stainless Steel Lifting Handle
- 2 Standard and Explosion Proof options
- 3 IE3 Rated Air Filled Motor
- 4 Side Entry Quick Disconnect Cord
- 5 High Capacity Sealed Bearings
- 6 Oil Filled Seal Chamber with Moisture Sensor
- 7 High Efficiency Clog Resistant Impeller & Volute Designs
- 8 Resicoat R4 Powder Coat Epoxy Paint

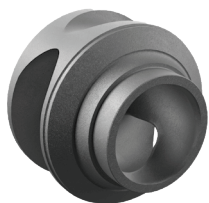
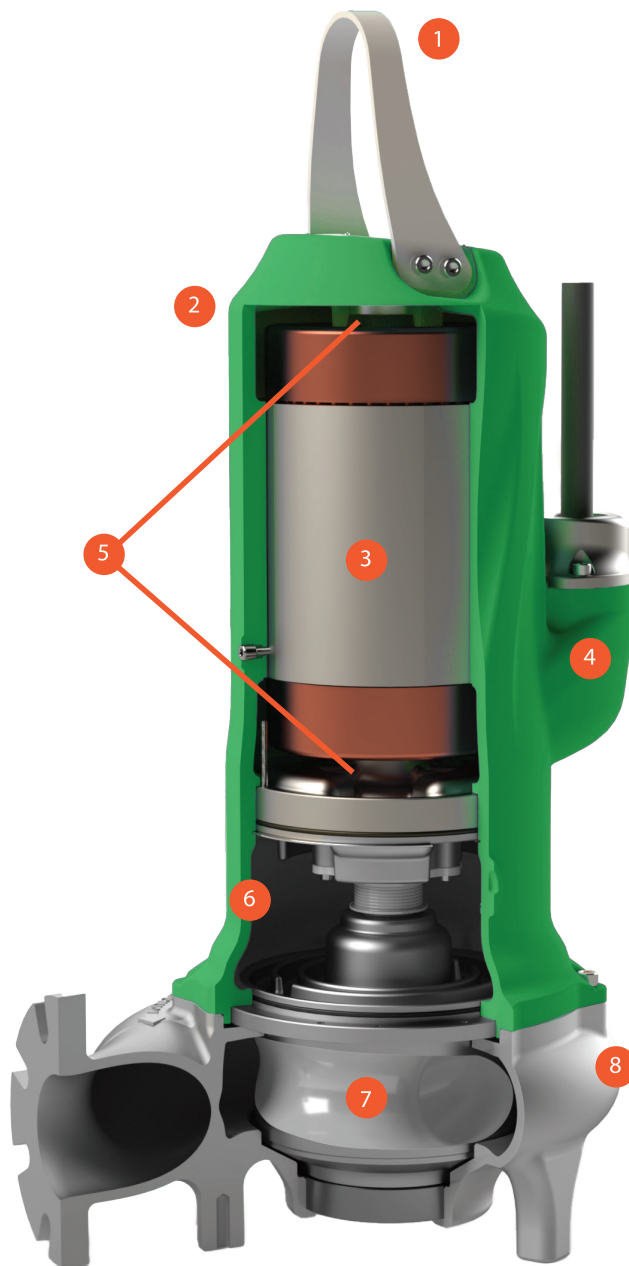

NEW SCROLL IMPELLER

Smooth flow passages create excellent solids handling performance while maintaining high hydraulic efficiency, which leads to lower horsepower requirements than the comparable non-clog solution.



NEW & IMPROVED VORTEX IMPELLER

Enhanced impeller and volute improvements deliver exceptional efficiency and clog resistance. The taller vanes and increased spacing improve performance, while the steep curves allow for smooth operation under challenging conditions.

TECHNICAL SPECIFICATIONS

- 3" and 4" Discharge, 3–15HP, 3450 and 1750 RPM
- Tandem Seal Design with Carbon/Silicon Carbide Upper Seal, Silicon Carbide/Silicon Carbide Lower Seal
- 30 ft Standard Cord, with longer options available
- Minimum 3" Spherical Solids Handling*
- Robust Cast Iron Construction with Powder Coat Epoxy Paint
- Class I, Div I, Groups C&D Explosion Proof Option
- Standard White Iron Impeller in Vortex Models, Option in All Others
- 5 Year Full Warranty
- Slotted Flange to Accommodate ANSI and ISO Connections

*Selected models only

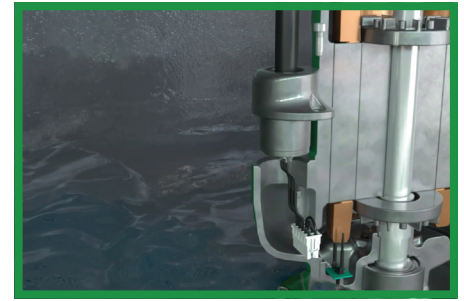

Easy installation with a stainless steel quick disconnect power cord



Our backwards-compatible design simplifies replacement and setup



The IE3 rated motor enables deeper pump-down depths and smooth pump operation even when partially unsubmerged

PERFORMANCE RANGE

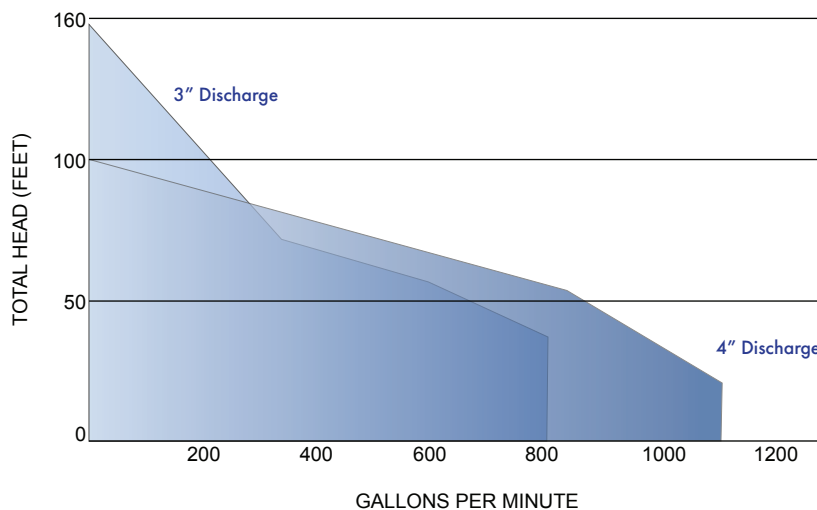

SUPERIOR SOLIDS HANDLING



INDUSTRY BEST LEAD TIME



HIGH RELIABILITY



ENERGY SAVINGS



EASE OF SERVICING



MADE IN THE USA



PUMPS & SYSTEMS

Crane Pumps & Systems
420 Third Street
Piqua, Ohio 45356
(937) 778-8947
www.cranepumps.com

Crane Pumps & Systems Canada
83 West Drive
Brampton, Ont. Canada L6T 2J6
(905) 457-6223

BARNES® BURKS® CROWN® DEMING® PROSSER® WEINMAN®

Order Online: www.PumpCatalog.com