

EOM

ENGINEERING OPERATION
& MAINTENANCE

P100 Bolted Plastic Pump

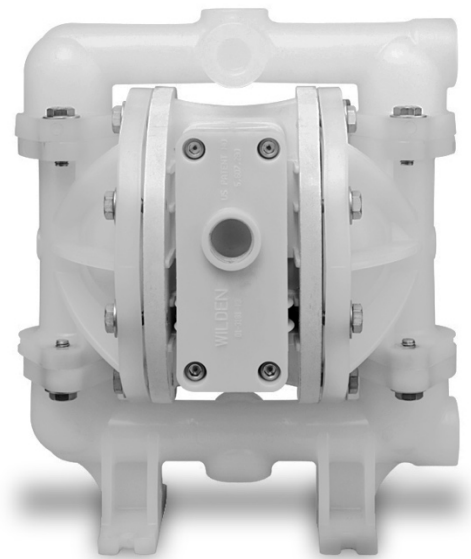

Where Innovation Flows

WILDEN®

Contents

Section 1: Precautions - Read First!	4
Section 2: Wilden Pump Designation System	5
Section 3: How It Works—Pump & Air Distribution System	6
Section 4: Dimensional Drawings	7
P100 Advanced™ Plastic.....	8
P100 Advanced™ Plastic - Center Ported.....	8
P100 Advanced™ Plastic - Vertical Ported.....	8
Section 5: Performance	10
P100 Advanced™ Plastic Rubber-Fitted.....	10
P100 Advanced™ Plastic TPE-Fitted.....	10
P100 Advanced™ Plastic PTFE-Fitted.....	11
Suction-Lift Curves.....	12
Section 6: Suggested Installation, Operation, Maintenance and Troubleshooting	13
Section 7: Disassembly / Reassembly	16
Pump Disassembly.....	16
Air Valve / Center Section Disassembly.....	19
Reassembly Hints & Tips.....	21
Section 8: Exploded View and Parts List	23
P100 Advanced™ Plastic PTFE/PTFE-IPD-Fitted.....	23
Section 9: Elastomer Options	25

Copyright

Copyright 2018 PSG[®], a Dover Company. All rights reserved.

PSG reserves the right to modify the information and illustrations in this document without prior notice. The product described in this document is furnished under a license agreement or nondisclosure agreement. No part of this document may be reproduced, stored in a retrieval system, or transmitted in any form or any means electronic or mechanical, including photocopying and recording, without the written permission of PSG, a Dover Company, except as described by the terms of those agreements.

This is a non-contractual document. 01-2019.

Trademarks

PSG and the PSG logo are registered trademarks of PSG. Wilden[®] is a registered trademark of PSG California LLC. Pro-Flo[®] SHIFT and Pro-Flo[®] are registered trademarks of PSG California LLC. Wil-Flex[®] is a trademark of PSG California LLC. Saniflex[™] is a trademark of PSG California LLC.

All trademarks, names, logos and service marks (collectively "trademarks") in this document are registered and unregistered trademarks of their respective owners. Nothing contained in this document should be construed as granting any license or right to use any trademark without the prior written permission of the trademark owner.

Warranty

Each and every product manufactured by Wilden is built to meet the highest standards of quality. Every pump is functionally tested to insure integrity of operation. Wilden warrants that pumps, accessories and parts manufactured or supplied by it to be free from defects in material and workmanship for a period of five (5) years from date of installation or six (6) years from date of manufacture, whichever comes first.

For more information, and to register your Wilden pump for warranty, please visit <https://www.psgdover.com/wilden/support/warranty-registration>.

Certifications



Section 1

Precautions - Read First!



TEMPERATURE LIMITS*:

Wetted Path		
Polypropylene (PP)	0°C to 79.4°C	32°F to 175°F
Polyvinylidene fluoride (PVDF)	-12.2°C to 107.2°C	10°F to 225°F
Elastomers		
Neoprene	-17.8°C to 93.3°C	0°F to 200°F
Buna-N	-12.2°C to 82.2°C	10°F to 180°F
FKM	-40°C to 176.7°C	-40°F to 350°F
Wil-Flex™	-40°C to 107.2°C	-40°F to 225°F
Polyurethane	12.2°C to 65.6°C	10°F to 150°F
Polytetrafluoroethylene (PTFE)	4.4°C to 104.4°C	40°F to 220°F
Saniflex™	-28.9°C to 104.4°C	-20°F to 220°F

*Elastomer choice may change temperature limits.

NOTE: Not all materials are available for all models. Refer to Section 2 for material options for your pump.



CAUTION: When choosing pump materials, be sure to check the temperature limits for all wetted components. Example: FKM has a maximum limit of 176.7°C (350°F) but polypropylene has a maximum limit of only 79.4°C (175°F).



CAUTION: Maximum temperature limits are based upon mechanical stress only. Certain chemicals will significantly reduce maximum safe operating temperatures. Consult engineering guide for chemical compatibility and temperature limits.



CAUTION : Always wear safety glasses when operating pump. If diaphragm rupture occurs, material being pumped may be forced out air exhaust.



WARNING: Prevention of static sparking — If static sparking occurs, fire or explosion could result. Proper grounding of pump, valves, and containers is critical when handling flammable fluids or whenever discharge of static electricity is a hazard.



CAUTION: Do not exceed 8.6 bar (125 psig) air supply pressure.



CAUTION: Advanced™ series plastic pumps are made with plastic that is not UV stabilized. Direct sunlight for prolonged periods can cause deterioration of plastics.



CAUTION: Before any maintenance or repair is attempted, the compressed air line to the pump should be disconnected and all air pressure allowed to bleed from pump. Disconnect all intake, discharge and air lines. Drain the pump by turning it upside down and allowing any fluid to flow into a suitable container.



CAUTION: Blow out air line for 10 to 20 seconds before attaching to pump to make sure all pipe line debris is clear. Use an in-line air filter. A 5µ (micron) air filter is recommended.



NOTE: Tighten all bolts prior to installation. Fasteners may loosen during transportation. See torque specifications on page 21.



NOTE: When installing polytetrafluoroethylene (PTFE) diaphragms, it is important to tighten outer pistons simultaneously (turning in opposite directions) to ensure tight fit.



CAUTION : Verify the chemical compatibility of the process and cleaning fluid to the pump's component materials in the Chemical Resistance Guide (see E4).



CAUTION: When removing the end cap using compressed air, the air valve end cap may come out with considerable force. Hand protection such as a padded glove or rag should be used to capture the end cap.



CAUTION: Do not over-tighten the air inlet reducer bushing. Additionally, too much torque on the muffler may damage the air valve muffler plate.

Section 2

WILDEN PUMP DESIGNATION SYSTEM

**P100 ADVANCED™
PLASTIC**

**13 mm (1/2") Pump
Maximum Flow Rate:
58.7 LPM (15.5 GPM)**

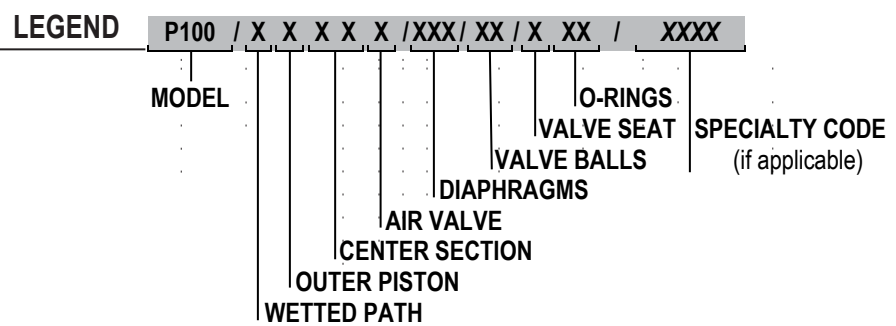

MATERIAL CODES

MODEL

P100 = PRO-FLO®

WETTED PATH

P = POLYPROPYLENE
K = PVDF

OUTER PISTON

P = POLYPROPYLENE
K = PVDF
Z = NO OUTER PISTON

CENTER SECTION

PP = POLYPROPYLENE

AIR VALVE

P = POLYPROPYLENE

DIAPHRAGMS

BNS = BUNA-N (Red Dot)
FSS = SANIFLEX™
[Hytrel® (Cream)]
PUS = POLYURETHANE (Clear)
THU = PTFE W/HI-TEMP
BUNA-N BACK-UP (White)
TNL = PTFE W/NEOPRENE
BACK-UP, IPD (White)
TNU = PTFE W/NEOPRENE
BACK-UP (White)
VTS = FKM (White Dot)
WFS = WIL-FLEX™ [Santoprene®
(Three Black Dots)]

VALVE BALLS

BN = BUNA-N (Red Dot)
FS = SANIFLEX™ [Hytrel® (Cream)]
PU = POLYURETHANE (Brown)
TF = PTFE (White)
VT = FKM (White Dot)
WF = WIL-FLEX™ [Santoprene®
(Three Black Dots)]

VALVE SEATS

K = PVDF
P = POLYPROPYLENE

VALVE SEAT O-RINGS

BN = BUNA-N
PU = POLYURETHANE (Brown)
TV = PTFE ENCAP. FKM
WF = WIL-FLEX (Santoprene®)
VT = FKM

SPECIALTY CODES

0014 BSPT	0680 P100 with OEM specific inlet manifold
0102 Wil-GardII™, sensorwires ONLY	0683 P100 with OEM specific inlet manifold, center ported inlet and discharge manifolds, NPT
0677 Center ported, NPT (Parts Only)	0790 P100 Advanced, drum pump inlet manifold
0678 Center ported, BSPT (Parts Only)	

NOTE: Most Elastomeric materials use colored dots for identification.

NOTE: Not all models are available with all material options.

Hytrel® is a registered trademark of DuPont Dow Elastomers.

Section 3

HOW IT WORKS — PUMP

The Wilden diaphragm pump is an air-operated, positive displacement, self-priming pump. These drawings show the flow pattern through the pump upon its initial stroke. It is assumed the pump has no fluid in it prior to its initial stroke.

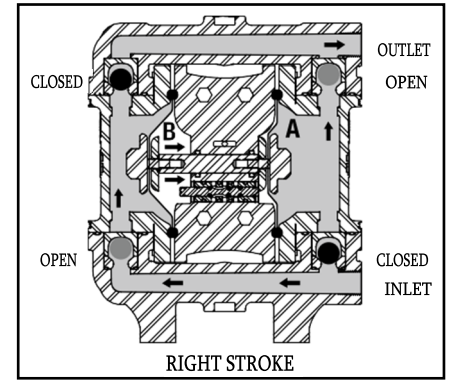
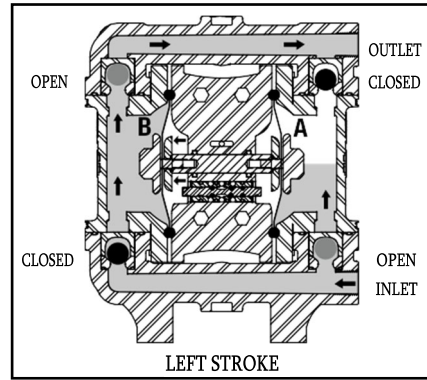
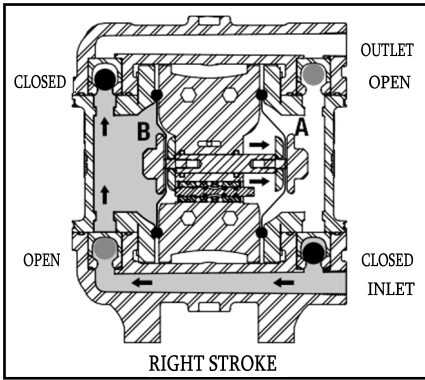
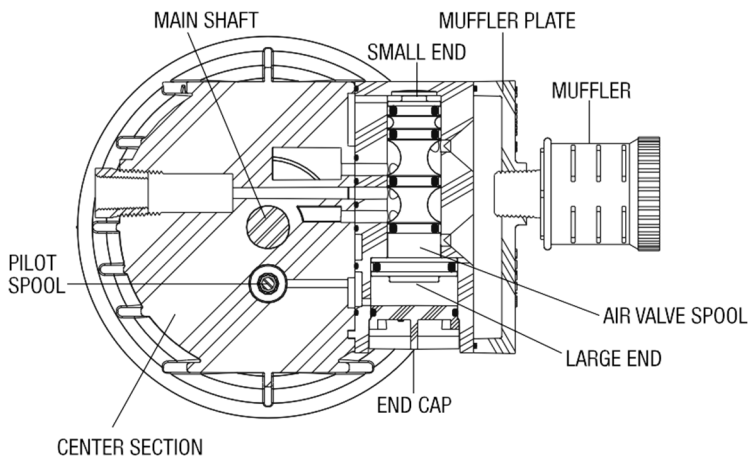

FIGURE 1 The air valve directs pressurized air to the back side of diaphragm A. The compressed air is applied directly to the liquid column separated by elastomeric diaphragms. The diaphragm acts as a separation membrane between the compressed air and liquid, balancing the load and removing mechanical stress from the diaphragm. The compressed air moves the diaphragm away from the center section of the pump. The opposite diaphragm is pulled in by the shaft connected to the pressurized diaphragm. Diaphragm B is on its suction stroke; air behind the diaphragm has been forced out to the atmosphere through the exhaust port of the pump. The movement of diaphragm B toward the center section of the pump creates a vacuum within chamber B. Atmospheric pressure forces fluid into the inlet manifold forcing the inlet valve ball off its seat. Liquid is free to move past the inlet valve ball and fill the liquid chamber (see shaded area).

FIGURE 2 When the pressurized diaphragm, diaphragm A, reaches the limit of its discharge stroke, the air valve redirects pressurized air to the back side of diaphragm B. The pressurized air forces diaphragm B away from the center section while pulling diaphragm A to the center section. Diaphragm B is now on its discharge stroke. Diaphragm B forces the inlet valve ball onto its seat due to the hydraulic forces developed in the liquid chamber and manifold of the pump. These same hydraulic forces lift the discharge valve ball off its seat, while the opposite discharge valve ball is forced onto its seat, forcing fluid to flow through the pump discharge. The movement of diaphragm A toward the center section of the pump creates a vacuum within liquid chamber A. Atmospheric pressure forces fluid into the inlet manifold of the pump. The inlet valve ball is forced off its seat allowing the fluid being pumped to fill the liquid chamber.

FIGURE 3 At completion of the stroke, the air valve again redirects air to the back side of diaphragm A, which starts diaphragm B on its exhaust stroke. As the pump reaches its original starting point, each diaphragm has gone through one exhaust and one discharge stroke. This constitutes one complete pumping cycle. The pump may take several cycles to completely prime depending on the conditions of the application.

HOW IT WORKS — AIR DISTRIBUTION SYSTEM



The Pro-Flo® patented air distribution system incorporates three moving parts: the air valve spool, the pilot spool, and the main shaft/diaphragm assembly. The heart of the system is the air valve spool and air valve. This valve design incorporates an unbalanced spool. The smaller end of the spool is pressurized continuously, while the large end is alternately pressurized then exhausted to move the spool. The spool directs pressurized air to one air chamber while exhausting the other. The air causes the main shaft/diaphragm assembly to shift to one side — discharging liquid on that side and pulling liquid in on the other side. When the shaft reaches the end of its stroke, the inner piston actuates the pilot spool, which pressurizes and exhausts the large end of the air valve spool. The repositioning of the air valve spool routes the air to the other air chamber.

DIMENSIONAL DRAWING

P100 Advanced™ Plastic

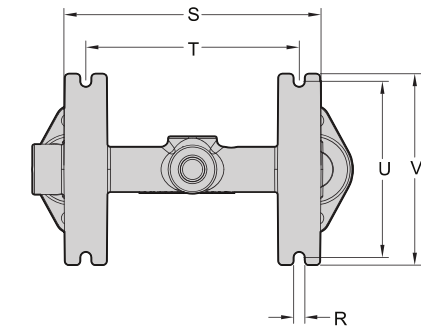
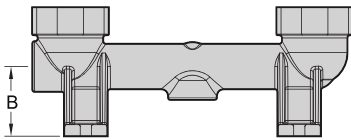
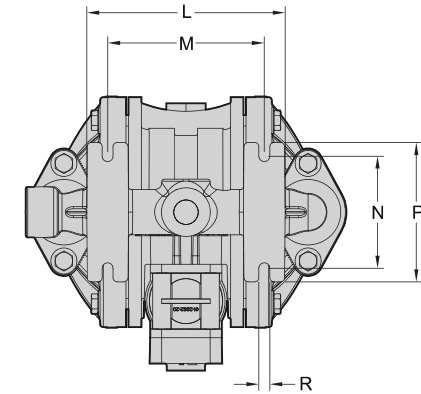
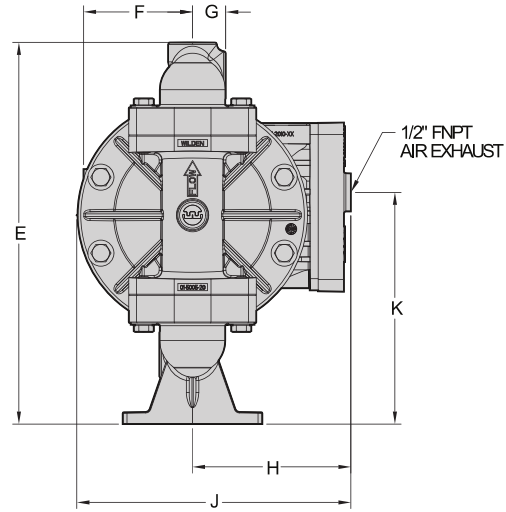
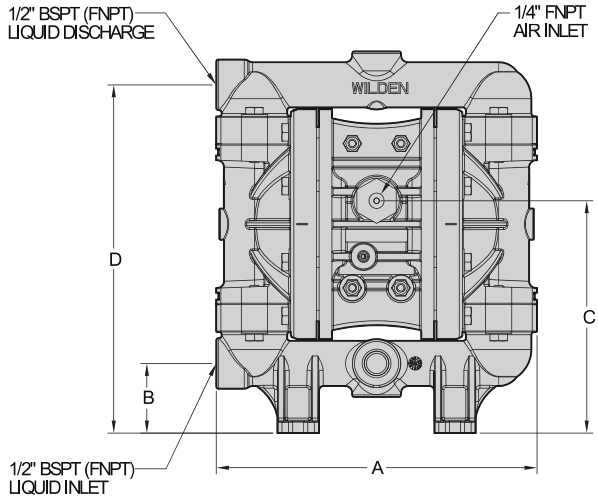

ALTERNATE FOOTPRINT

DIMENSIONS

ITEM	METRIC (mm)	STANDARD (inch)
A	234	9.2
B	51	2.0
C	170	6.7
D	254	10.0
E	279	11.0
F	81	3.2
G	25	1.0
H	114	4.5
J	201	7.9
K	170	6.7
L	145	5.7
M	114	4.5
N	81	3.6
P	102	4.0
R	8	0.3
S	188	7.4
T	155	6.1
U	130	5.1
V	140	5.5

LW0347 REV B

DIMENSIONAL DRAWING

P100 Advanced™ Plastic - Center Ported

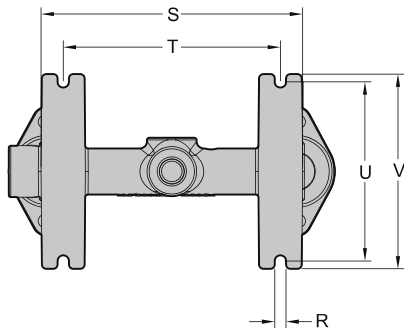
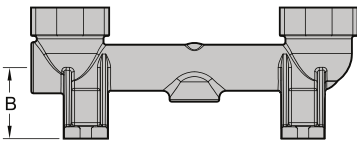
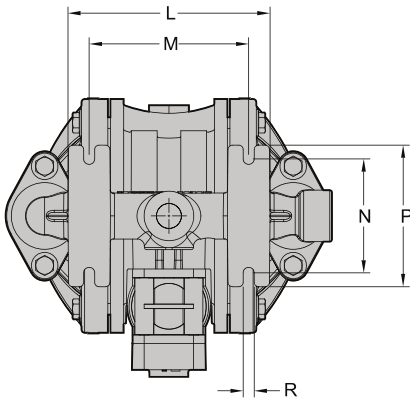
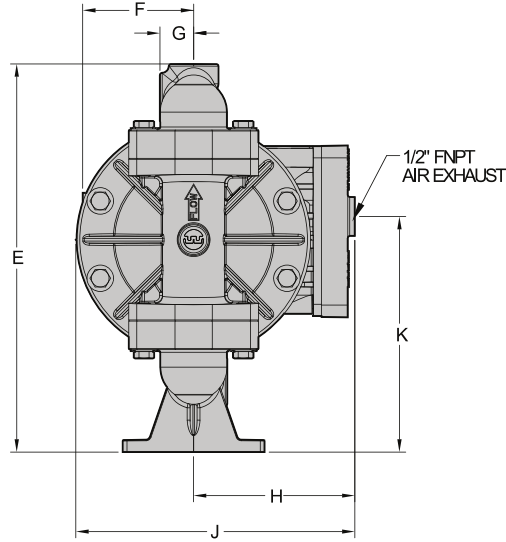
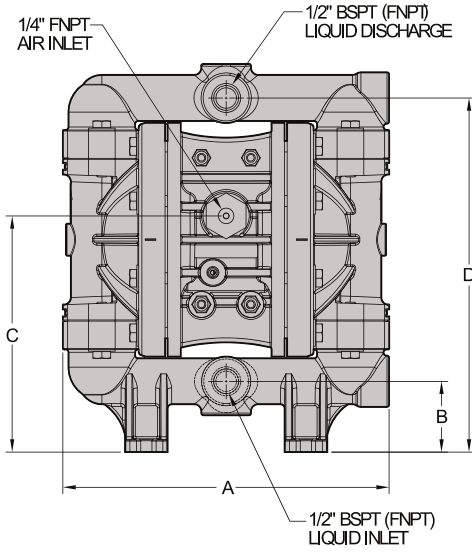

ALTERNATE FOOTPRINT

DIMENSIONS

ITEM	METRIC (mm)	STANDARD (inch)
A	234	9.2
B	51	2.0
C	170	6.7
D	254	10.0
E	279	11.0
F	81	3.2
G	25	1.0
H	114	4.5
J	201	7.9
K	170	6.7
L	145	5.7
M	114	4.5
N	81	3.6
P	102	4.0
R	8	0.3
S	188	7.4
T	155	6.1
U	130	5.1
V	140	5.5

LW0472 REV A

DIMENSIONAL DRAWING

P100 Advanced™ Plastic - Vertical Ported

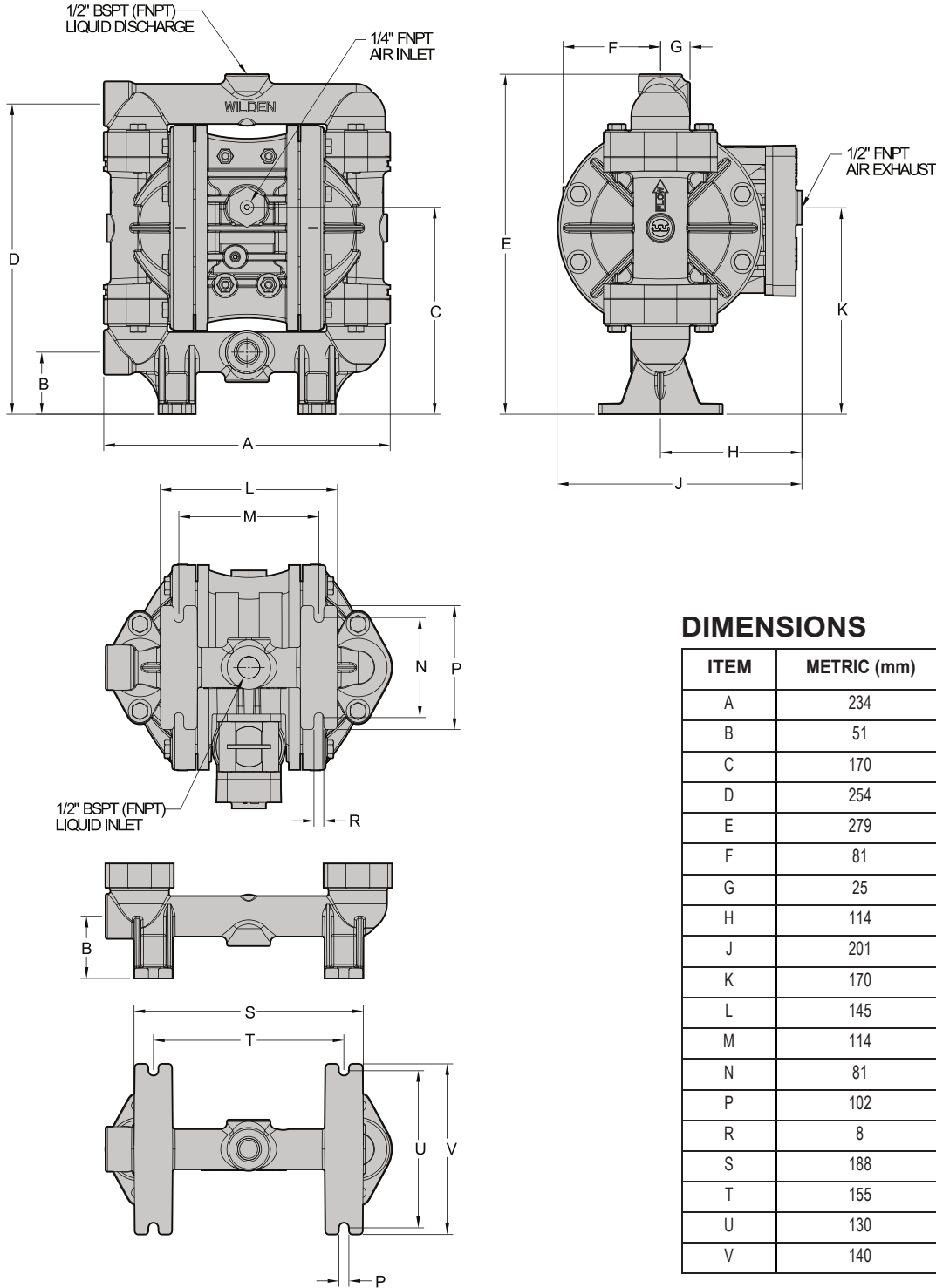

DIMENSIONS

ITEM	METRIC (mm)	STANDARD (inch)
A	234	9.2
B	51	2.0
C	170	6.7
D	254	10.0
E	279	11.0
F	81	3.2
G	25	1.0
H	114	4.5
J	201	7.9
K	170	6.7
L	145	5.7
M	114	4.5
N	81	3.6
P	102	4.0
R	8	0.3
S	188	7.4
T	155	6.1
U	130	5.1
V	140	5.5

LW0473 REV A

Section 5

PERFORMANCE

P100 PLASTIC RUBBER-FITTED

Ship WeightPolypropylene 4 kg (8 lbs)
PVDF 5 kg (10 lbs)
Air Inlet 6 mm (1/4")
Inlet..... 13 mm (1/2")
Outlet..... 13 mm (1/2")
Suction Lift..... 5.2 m Dry (17.0')
8.7 m Wet (28.4')
Disp. Per Stroke¹..... 0.10 l (0.027 gal.)
Max. Flow Rate 56.0 lpm (14.8 gpm)
Max. Size Solids..... 1.6 mm (1/16")

¹Displacement per stroke was calculated at 4.8 bar (70 psig) air inlet pressure against a 2 bar (30 psig) head pressure.

Example: To pump 32.9 lpm (8.7 gpm) against a discharge head pressure of 4.1 bar (60 psig) requires 5.5 bar (80 psig) and 27.2 Nm³/h (16 scfm) air consumption. (See dot on chart.)

Do not exceed 8.6 bar (125 psig) air supply pressure.

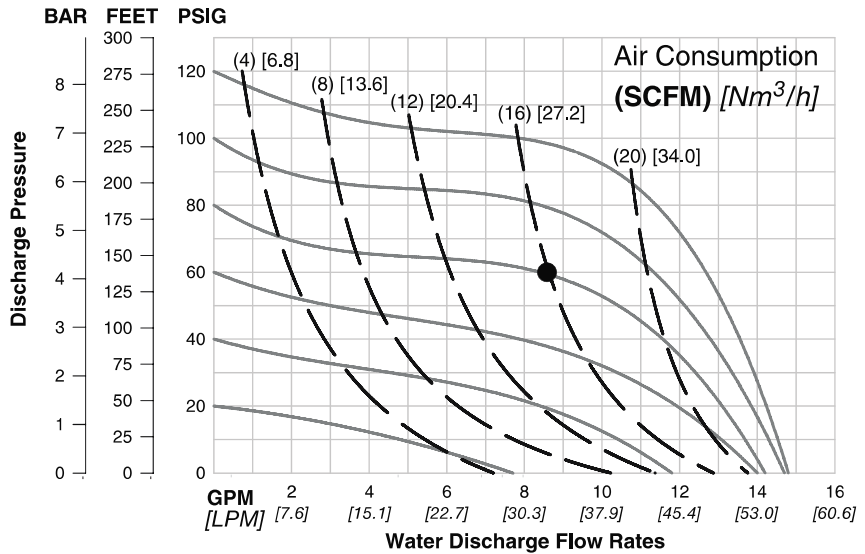

Flow rates indicated on chart were determined by pumping water.

For optimum life and performance, pumps should be specified so that daily operation parameters will fall in the center of the pump performance curve.

P100 PLASTIC TPE-FITTED

Ship Weight....Polypropylene 4 kg (8 lbs)
PVDF 5 kg (10 lbs)
Air Inlet 6 mm (1/4")
Inlet..... 13 mm (1/2")
Outlet..... 13 mm (1/2")
Suction Lift 5.5 m Dry (17.0')
8.7 m Wet (28.4')
Disp. Per Stroke¹..... 0.11 l (0.029 gal.)
Max. Flow Rate 58.7 lpm (15.5 gpm)
Max. Size Solids 1.6 mm (1/16")

¹Displacement per stroke was calculated at 4.8 bar (70 psig) air inlet pressure against a 2 bar (30 psig) head pressure.

Example: To pump 34.8 lpm (9.2 gpm) against a discharge head pressure of 2.4 bar (35 psig) requires 4.1 bar (60 psig) and 27.2 Nm³/h (16 scfm) air consumption. (See dot on chart.)

Caution: Do not exceed 8.6 bar (125 psig) air supply pressure.

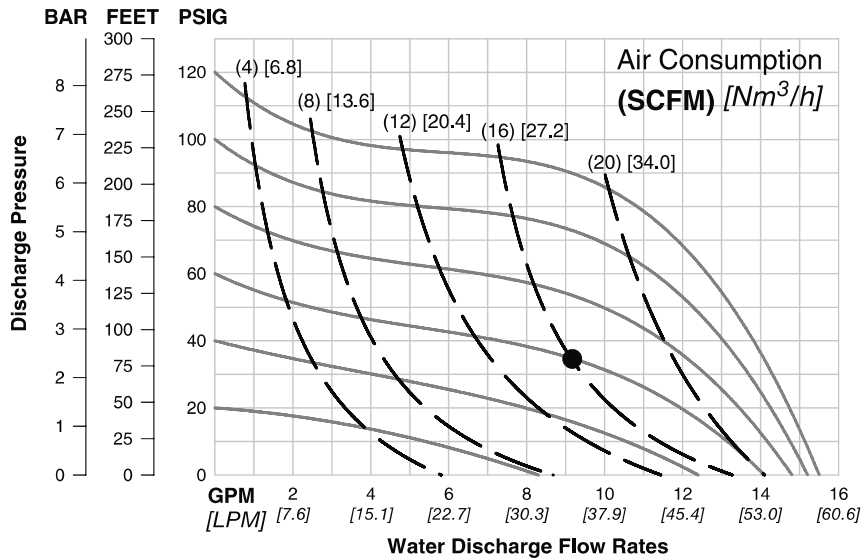

Flow rates indicated on chart were determined by pumping water.

For optimum life and performance, pumps should be specified so that daily operation parameters will fall in the center of the pump performance curve.

PERFORMANCE

**P100 PLASTIC
PTFE-FITTED**

Ship Weight..... Polypropylene 4 kg (8 lbs)
 PVDF 5 kg (10 lbs)
 Air Inlet 6 mm (1/4")
 Inlet..... 13 mm (1/2")
 Outlet..... 13 mm (1/2")
 Suction Lift
 4.5 m Dry (14.7')
 9.3 m Wet (30.6')
 Disp. Per Stroke¹..... 0.10 l (0.027 gal.)
 Max. Flow Rate57.0 lpm (15.0 gpm)
 Max. Size Solids 1.6 mm (1/16")

¹Displacement per stroke was calculated at 4.8 bar (70 psig) air inlet pressure against a 2 bar (30 psig) head pressure.

Example: To pump 20.8 lpm (5.5 gpm) against a discharge head pressure of 1.4 bar (20 psig) requires 2.8 bar (40 psig) and 13.6 Nm³/h (8 scfm) air consumption. (See dot on chart.).

Caution: Do not exceed 8.6 bar (125 psig) air supply pressure.

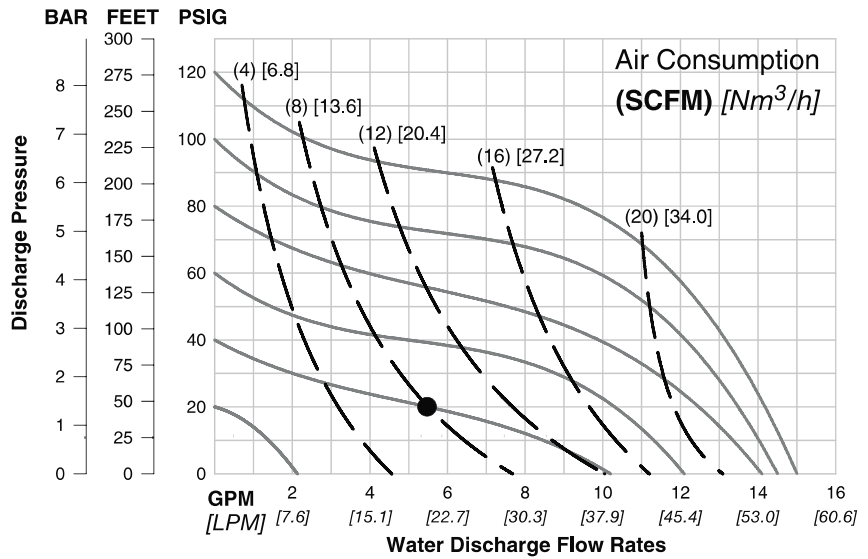

Flow rates indicated on chart were determined by pumping water.

For optimum life and performance, pumps should be specified so that daily operation parameters will fall in the center of the pump performance curve.

SUCTION LIFT CURVES

P100 PLASTIC SUCTION - LIFT CAPABILITY

Suction lift curves are calibrated for pumps operating at 305 m (1,000') above sea level. This chart is meant to be a guide only. There are many variables which can affect your pump's operating characteristics. The number of intake and discharge elbows, viscosity of pumping fluid, elevation (atmospheric pressure) and pipe friction loss all affect the amount of suction lift your pump will attain.

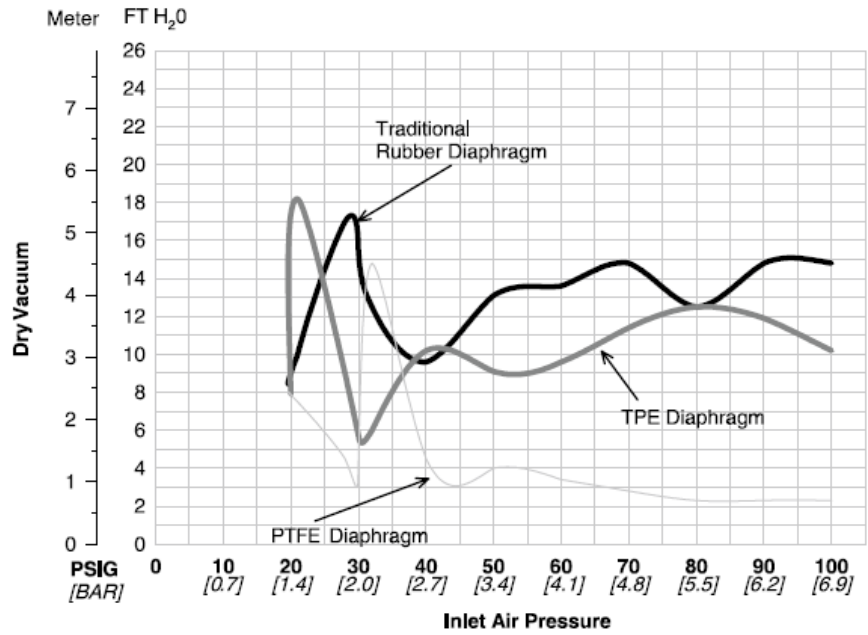

Section 6

Suggested Installation, Operation, Maintenance and Troubleshooting

The Pro-Flo® model **P100 Advanced™** plastic has a 13 mm (1/2") inlet and 13 mm (1/2") outlet and is designed for flows to 58.7 lpm (15.5 gpm). The **P100 Advanced™** plastic pump is manufactured with wetted parts of pure, unpigmented Polypropylene or PVDF. The **P100 Advanced™** plastic pump is constructed with a glass fiber filled PP center section. A variety of diaphragms and o-rings are available to satisfy temperature, chemical compatibility, abrasion, and flex concerns.

The suction pipe size should be at least 13 mm (1/2") diameter or larger if highly viscous material is being pumped. The suction hose must be non-collapsible, reinforced type as the **P100 Advanced™** plastic pump is capable of pulling a high vacuum. Discharge piping should be at least 13 mm (1/2"); larger diameter can be used to reduce friction losses. It is critical that all fittings and connections are airtight or a reduction or loss of pump suction capability will result.

 **CAUTION:** All fittings and connections must be airtight. Otherwise, pump suction capability will be reduced or lost.

Months of careful planning, study and selection efforts can result in unsatisfactory pump performance if installation details are left to chance. You can avoid premature failure and long-term dissatisfaction by exercising reasonable care throughout the installation process.

Location

Noise, safety and other logistical factors usually dictate where equipment will be situated on the production floor. Multiple installations with conflicting requirements can result in congestion of utility areas, leaving few choices for additional pumps.

Within the framework of these and other existing conditions, every pump should be located in such a way that several key factors are balanced against each other to maximum advantage.:

- **Access:** First of all, the location should be accessible. If it's easy to reach the pump, maintenance personnel will have an easier time carrying out routine inspections and adjustments. Should major repairs become necessary, ease of access can play a key role in speeding the repair process and reducing total downtime.
- **Air Supply:** Every pump location should have an air line large enough to supply the volume of air necessary to achieve the desired pumping rate. Use air pressure up to a maximum of 8.6 bar (125 psig) depending on pumping requirements.
For best results, the pumps should use a 5µ (micron) air filter, needle valve and regulator. The use of an air filter before the pump will ensure that the majority of any pipeline contaminants will be eliminated.
- **Solenoid Operation:** When operation is controlled by a solenoid valve in the air line, three-way valves should be used. This valve allows trapped air between the valve and the pump to bleed off which improves pump performance. Pumping volume can be estimated by counting the number of strokes per minute and then multiplying the figure by the displacement per stroke.
- **Muffler:** Sound levels are reduced below OSHA specifications using the standard Wilden muffler. Other mufflers can be used to further reduce sound levels, but they usually reduce pump performance.

- **Elevation:** Selecting a site that is well within the pump's dynamic-lift capability will assure that loss-of-prime issues will be eliminated. In addition, pump efficiency can be adversely affected if proper attention is not given to site location.
- **Piping:** Final determination of the pump site should not be made until the piping challenges of each possible location have been evaluated. The impact of current and future installations should be considered ahead of time to make sure that inadvertent restrictions are not created for any remaining sites.

The best choice possible will be a site involving the shortest and straightest hook-up of suction and discharge piping. Unnecessary elbows, bends and fittings should be avoided. Pipe sizes should be selected to keep friction losses within practical limits. All piping should be supported independently of the pump. In addition, the piping should be aligned to avoid placing stress on the pump fittings.

Flexible hose can be installed to aid in absorbing the forces created by the natural reciprocating action of the pump. If the pump is to be bolted down to a solid location, a mounting pad placed between the pump and the foundation will assist in minimizing pump vibration. Flexible connections between the pump and rigid piping will also assist in minimizing pump vibration. If quick-closing valves are installed at any point in the discharge system, or if pulsation within a system becomes a problem, a surge suppressor (SD Equalizer®) should be installed to protect the pump, piping and gauges from surges and water hammer.

The **P100 Advanced™** plastic Pro-Flo® equipped pump can be installed in submersible applications only when both the wetted and non-wetted portions are compatible with the material being pumped. If the pump is to be used in a submersible application, a hose should be attached to the air and pilot spool exhaust ports of the pump. These should then be piped above the liquid level. The exhaust area for the pilot spool is designed to be tapped for a 1/8" NPT fitting.

If the pump is to be used in a self-priming application, make sure that all connections are airtight and that the suction lift is within the model's ability.

 **NOTE:** Materials of construction and elastomer material have an effect on suction-lift parameters. Please refer to the performance section for specifics.

When pumps are installed in applications involving flooded suction or suction-head pressures, a gate valve should be installed in the suction line to permit closing of the line for pump service.

Pumps in service with a positive suction head are most efficient when inlet pressure is limited to 0.5–0.7 bar (7–10 psig). Premature diaphragm failure may occur if positive suction is 0.7 bar (10 psig) and higher.

 **CAUTION:** The model P100 Advanced™ plastic will pass 1.6 mm (1/16") solids. whenever the possibility exists that larger solid objects may be sucked into the pump, a strainer should be used on the suction line.

 **CAUTION:** Do not exceed 8.6 bar (125 psig) air supply pressure.

Suggested Installation, Operation, Maintenance and Troubleshooting

This illustration is a generic representation of an air-operated double-diaphragm pump.

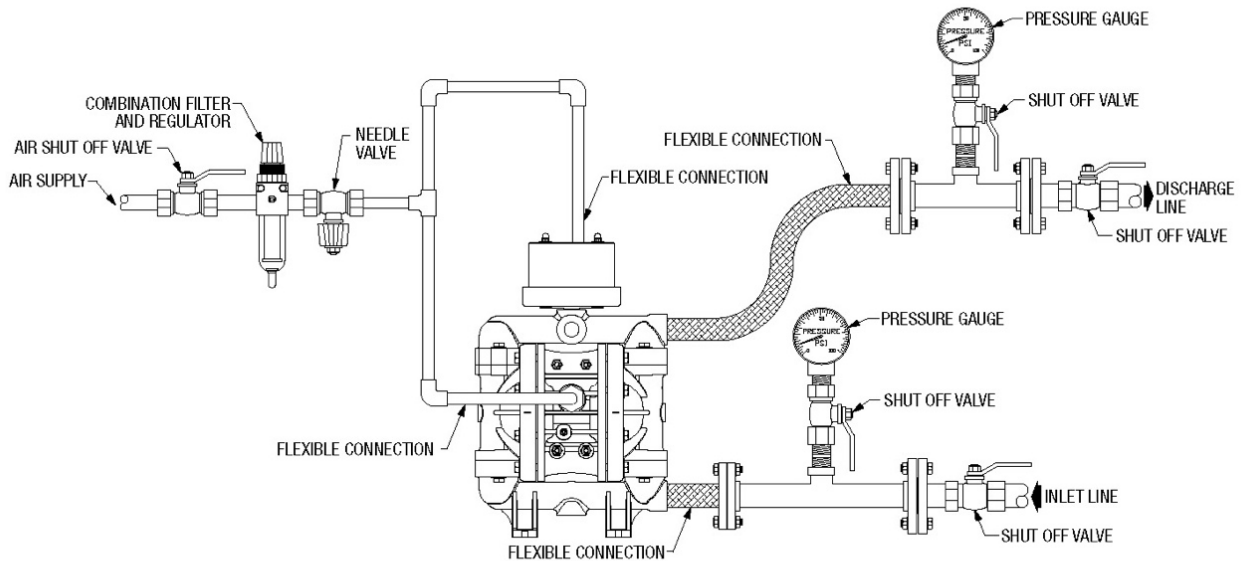

NOTE: In the event of a power failure, the shut-off valve should be closed, if the restarting of the pump is not desirable once power is regained.

Air-Operated Pumps: To stop the pump from operating in an emergency situation, simply close the shut-off valve (user-supplied) installed in the air supply line. A properly functioning valve will stop the air supply to the pump, therefore stopping output. This shut-off valve should be located far enough away from the pumping equipment such that it can be reached safely in an emergency situation

Operation

The P100 are pre-lubricated, and do not require in-line lubrication. Additional lubrication will not damage the pump, however if the pump is heavily lubricated by an external source, the pump's internal lubrication may be washed away. If the pump is then moved to a non-lubricated location, it may need to be disassembled and re-lubricated as described in the Disassembly/Reassembly Instructions.

Pump discharge rate can be controlled by limiting the volume and/or pressure of the air supply to the pump. An air regulator is used to regulate air pressure. A needle valve is used to regulate volume. Pump discharge rate can also be controlled by throttling the pump

discharge by partially closing a valve in the discharge line of the pump. This action increases friction loss which reduces flow rate. (See Section 5.) This is useful when the need exists to control the pump from a remote location. When the pump discharge pressure equals or exceeds the air supply pressure, the pump will stop; no bypass or pressure relief valve is needed, and pump damage will not occur. The pump has reached a "deadhead" situation and can be restarted by reducing the fluid discharge pressure or increasing the air inlet pressure. Wilden Pro-Flo® pumps run solely on compressed air and do not generate heat; therefore, your process fluid temperature will not be affected.

Maintenance and Inspections

Since each application is unique, maintenance schedules may be different for every pump. Frequency of use, line pressure, viscosity and abrasiveness of process fluid all affect the parts life of a Wilden pump. Periodic inspections have been found to offer the best means for preventing unscheduled pump downtime. Personnel familiar with the pump's construction and service should be informed of any abnormalities that are detected during operation.

Suggested Installation, Operation, Maintenance and Troubleshooting

Troubleshooting

Pump will not run or runs slowly.

1. Ensure that the air inlet pressure is at least 0.4 bar (5psig) above start up pressure and that the differential pressure (the difference between air inlet and liquid discharge pressures) is not less than 0.7 bar (10psig).
2. Check air inlet filter for debris (see SUGGESTED INSTALLATION).
3. Check for extreme air leakage (blow by) that would indicate worn seals/bores in the air valve, pilot spool and main shaft.
4. Disassemble pump and check for obstructions in the air passageways or objects that would obstruct the movement of internal parts.
5. Check for sticking ball check valves. If material being pumped is not compatible with pump elastomers, swelling may occur. Replace ball check valves and seals with proper elastomers. Also, as the check valve balls wear out, they become smaller and can become stuck in the seats. In this case, replace balls and seats.
6. Check for broken inner piston that will cause the air valve spool to be unable to shift.
7. Remove plug from pilot spool exhaust.

Pump runs but little or no product flows.

1. Check for pump cavitation; slow pump speed down to allow thick material to flow into liquid chambers.
2. Verify that vacuum required to lift liquid is not greater than the vapor pressure of the material being pumped (cavitation).

3. Verify that vacuum required to lift liquid is not greater than the vapor pressure of the material being pumped (cavitation).
4. Check for sticking ball check valves. If material being pumped is not compatible with pump elastomers, swelling may occur. Replace ball check valves and seats with proper elastomers. Also, as the check valve balls wear out, they become smaller and can become stuck in the seats. In this case, replace balls and seats.

Pump air valve freezes.

1. Check for excessive moisture in compressed air. Either install a dryer or hot-air generator for compressed air. Alternatively, a coalescing filter may be used to remove the water from the compressed air in some applications.

Air bubbles in pump discharge.

1. Check for ruptured diaphragm.
2. Check tightness of outer pistons (refer to Section 7).
3. Check tightness of fasteners and integrity of O-rings and seals, especially at intake manifold.
4. Ensure pipe connections are airtight.

Product comes out air exhaust.

1. Check for diaphragm rupture.
2. Check tightness of outer pistons to shaft.

Section 7

Disassembly / Reassembly

Pump Disassembly

Tools Required:

- 1/2" Box Wrench
- 2 – 1" Sockets or Adjustable Wrench
- Vise equipped with soft jaws (such as plywood, plastic or other suitable material)



CAUTION: Before any maintenance or repair is attempted, the compressed air line to the pump should be disconnected and all air pressure allowed to bleed from the pump. Disconnect all intake, discharge, and air lines. Drain the pump by turning it upside down and allowing any fluid to flow into a suitable container. Be aware of any hazardous effects of contact with your process fluid.



NOTE: The model used for these instructions incorporates PTFE diaphragms and balls. Models with rubber diaphragms and balls are the same except where noted.



NOTE: Replace worn parts with genuine Wilden parts for reliable performance.

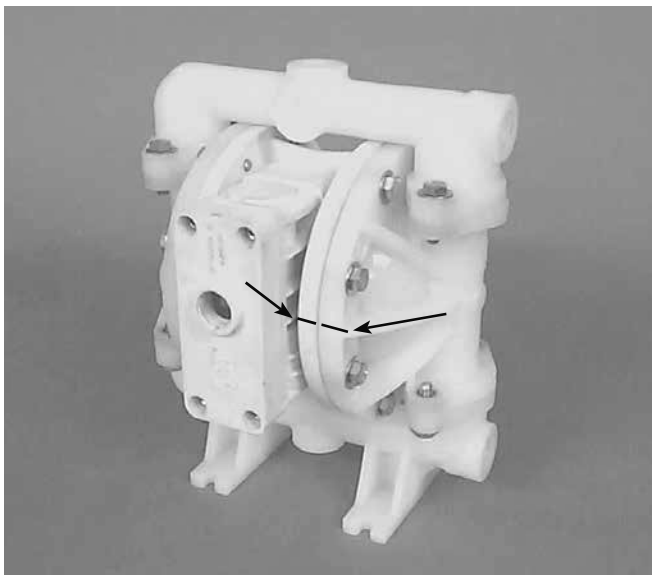

Step 1

Please see pre-molded alignment marks on the liquid chamber and center section.

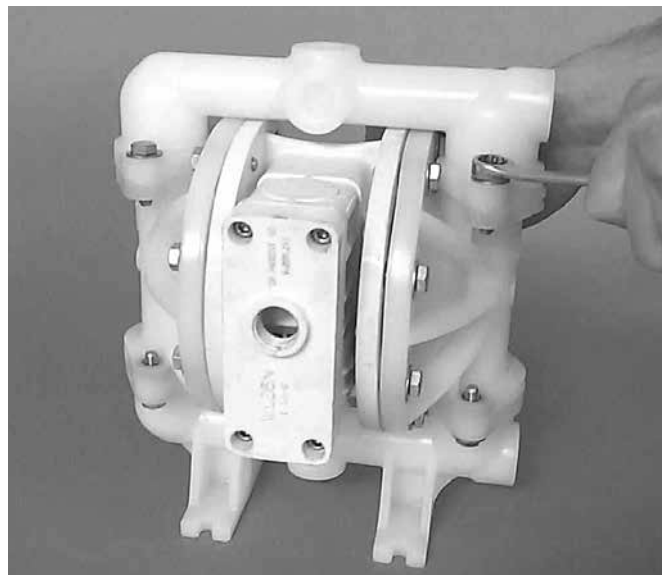

Step 2

Using the 1/2" box wrench, loosen the discharge manifold from the liquid chambers.

Disassembly / Reassembly



Step 3

Remove the discharge manifold to expose the valve balls, valve seats and valve seat o-rings.

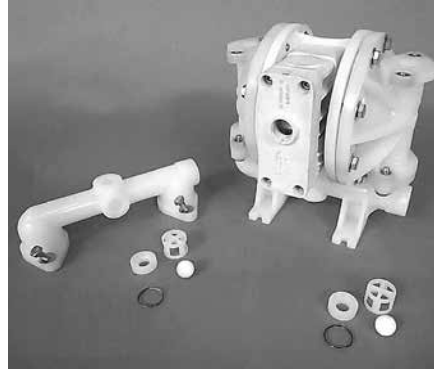

Step 4

Remove the discharge valve balls, seats and valve seat o-rings from the discharge manifold and liquid chamber, inspect for nicks, gouges, chemical attack or abrasive wear. Replace worn parts with genuine Wilden parts for reliable performance.



Step 5

Using a 1/2" box wrench, remove the inlet manifold.

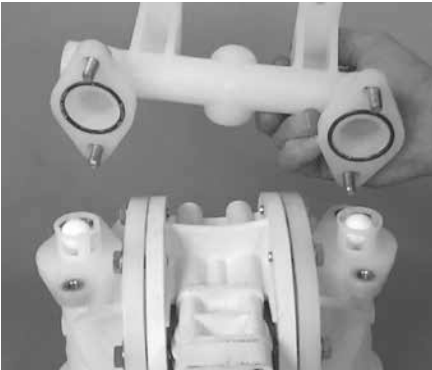

Step 6

Remove the inlet valve balls, seats and valve seat o-rings from the liquid chamber and discharge manifold, inspect for nicks, gouges, chemical attack or abrasive wear. Replace worn parts with genuine Wilden parts for reliable performance.

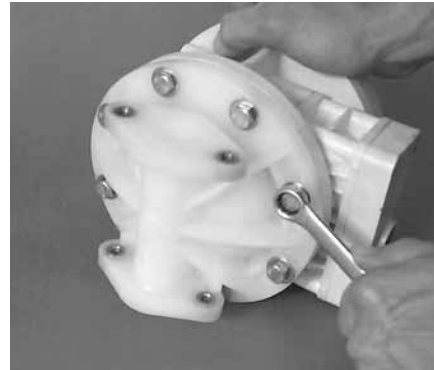

Step 7

With a 1/2" box wrench, remove the liquid chambers from the center section.



Step 8

The liquid chamber should be removed to expose the diaphragm and outer piston. Rotate center section and remove the opposite liquid chamber.

Disassembly / Reassembly

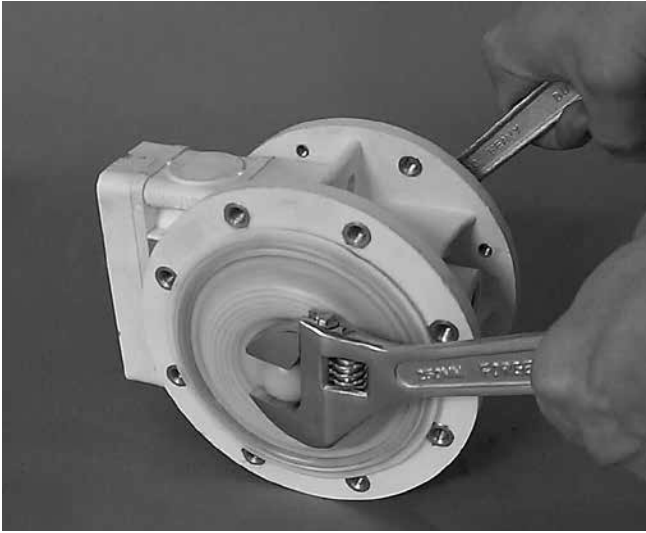

Step 9

Using two crescent wrenches or 1" sockets, remove diaphragm assembly from center section assembly.

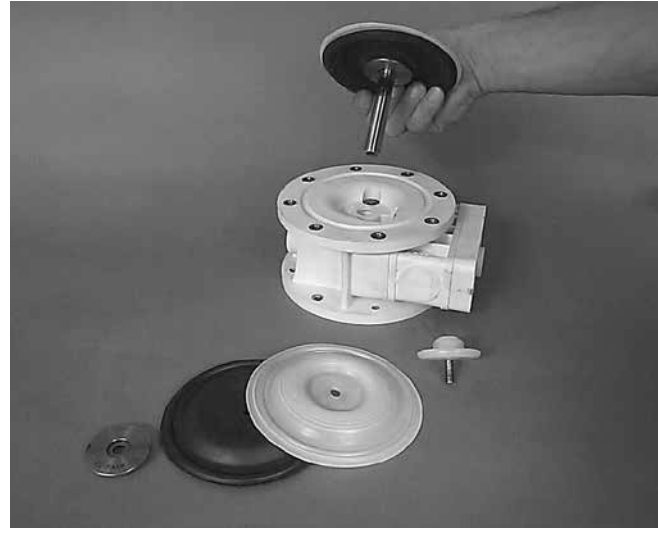

Step 10

After loosening and removing the outer piston the diaphragm assembly can be disassembled.



Step 11

To remove the remaining diaphragm assembly from the shaft, secure shaft with soft jaws (a vise fitted with plywood or other suitable material) to ensure shaft is not nicked, scratched, or gouged. Using an adjustable wrench, remove diaphragm assembly from shaft. Inspect all parts for wear and replace with genuine Wilden parts if necessary.

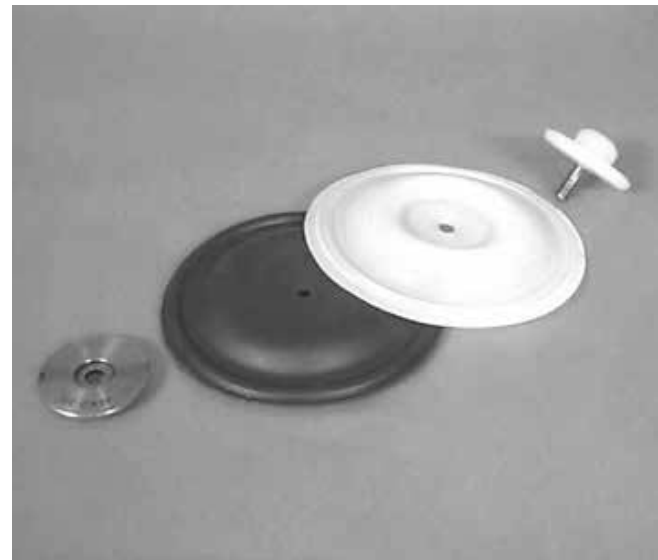

Step 12

Inspect diaphragms, outer and inner pistons for signs of wear. Replace with genuine Wilden parts if necessary.

Disassembly / Reassembly

Air Valve / Center Section Disassembly

Tools Required:

- 3/16" Allen Wrench
- Snap Ring Pliers
- O-Ring Pick



CAUTION: Before any maintenance or repair is attempted, the compressed air line to the pump should be disconnected and all air pressure allowed to bleed from the pump. Disconnect all intake, discharge, and air lines. Drain the pump by turning it upside down and allowing any fluid to flow into a suitable container. Be aware of hazardous effects of contact with your process fluid.

The Wilden P100 Advanced™ Plastic Pump utilizes a revolutionary Pro-Flo® air distribution system. A 6 mm (1/4") air inlet connects the air supply to the center section. Proprietary composite seals reduce the coefficient of friction and allow the P100 to run lube-free. Constructed of polypropylene, the Pro-Flo® air distribution system is designed to perform in on/off, non-freezing, non-stalling, tough duty applications.



NOTE: Replace worn parts with genuine Wilden parts for reliable performance.



Step 1

Loosen the air valve bolts utilizing a 3/16" Allen wrench.

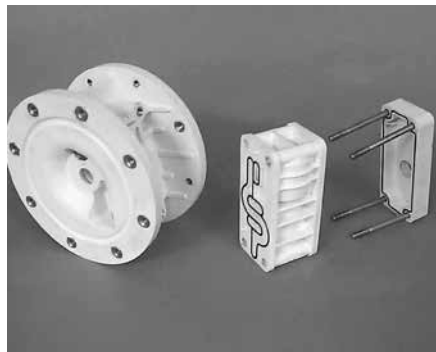

Step 2

Remove muffer plate and air valve bolts from air valve assembly exposing muffer gasket for inspection. Replace if necessary.



Step 3

Lift away air valve assembly and remove air valve gasket for inspection. Replace if necessary.

Disassembly / Reassembly

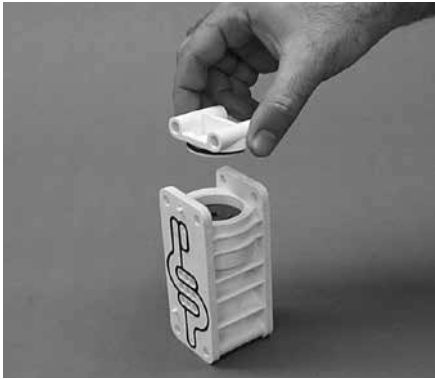

Step 4

Remove air valve end cap to expose air valve spool by simply lifting up on end cap once air valve bolts are removed.



Step 5

Remove air valve spool from air valve body by threading one air valve bolt into the end of the spool and gently sliding the spool out of the air valve body. Inspect seals for signs of wear and replace entire assembly if necessary. Use caution when handling air valve spool to prevent damaging seals.



NOTE: Seals should not be removed from assembly. Seals are not sold separately.

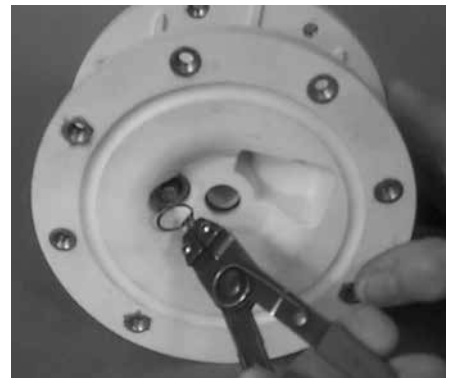

Step 6

Remove pilot spool sleeve retaining snap ring on both sides of center section with snap ring pliers.

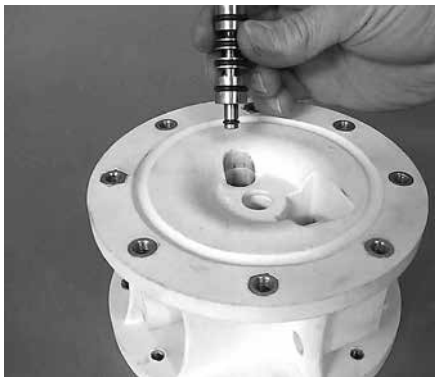

Step 7

Remove pilot spool sleeve from center section.



Step 8

With o-ring pick, gently remove the o-ring from the opposite side of the "center hole" cut on the spool. Gently remove the pilot spool from sleeve and inspect for nicks or gouges and other signs of wear. Replace pilot sleeve assembly or outer sleeve o-rings if necessary. During re-assembly never insert the pilot spool into the sleeve with the "center cut" side first, this end incorporates the urethane o-ring and will be damaged as it slides over the ports cut in the sleeve.



NOTE: Seals should not be removed from pilot spool. Seals are not sold separately.

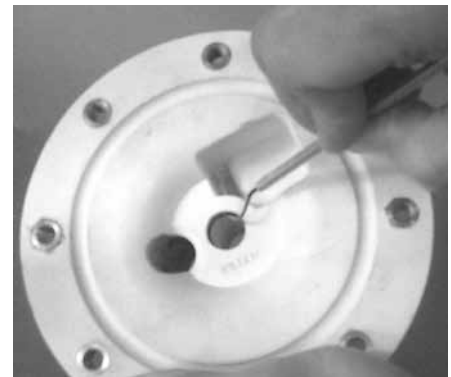

Step 9

Check center section Glyd™ rings for signs of wear. If necessary, remove Glyd™ rings with o-ring pick and replace.

Disassembly / Reassembly

Reassembly Hints & Tips

Upon performing applicable maintenance to the air distribution system, the pump can now be reassembled. Please refer to the disassembly instructions for photos and parts placement. To reassemble the pump, follow the disassembly instructions in reverse order. The air distribution system needs to be assembled first, then the diaphragms and finally the wetted path. Please find the applicable torque specifications on this page.

The following tips will assist in the assembly process.

- Clean the inside of the center section shaft bore to ensure no damage is done to new seals.
- Stainless bolts should be lubed to reduce the possibility of seizing during tightening.
- Be sure to tighten outer pistons simultaneously on PTFE- fitted pumps to ensure proper torque values.

- Apply a small amount of Loctite 242 to the shaft interval threads before the diaphragm assembly.
- Concave side of disc spring in diaphragm assembly faces **toward** inner piston.

PRO-FLO® MAXIMUM TORQUE SPECIFICATIONS

Description of Part	Torque
Pro-Flo® Air Valve	3.1 N•m (27 in-lbs)
Air Inlet Reducer Bushing	0.9 N•m (8 in-lbs)
Outer Piston	14.1 N•m (125 in-lbs)
Manifolds and Liquid Chambers	5.6 N•m (50 in-lbs)

Section 8

Exploded View and Parts Listing

P100 PLASTIC

EXPLODED VIEW

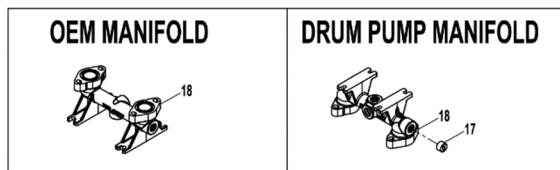
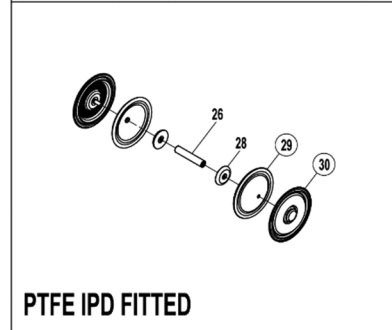
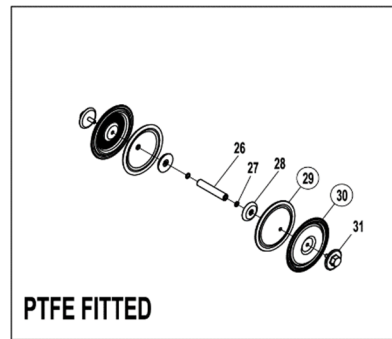
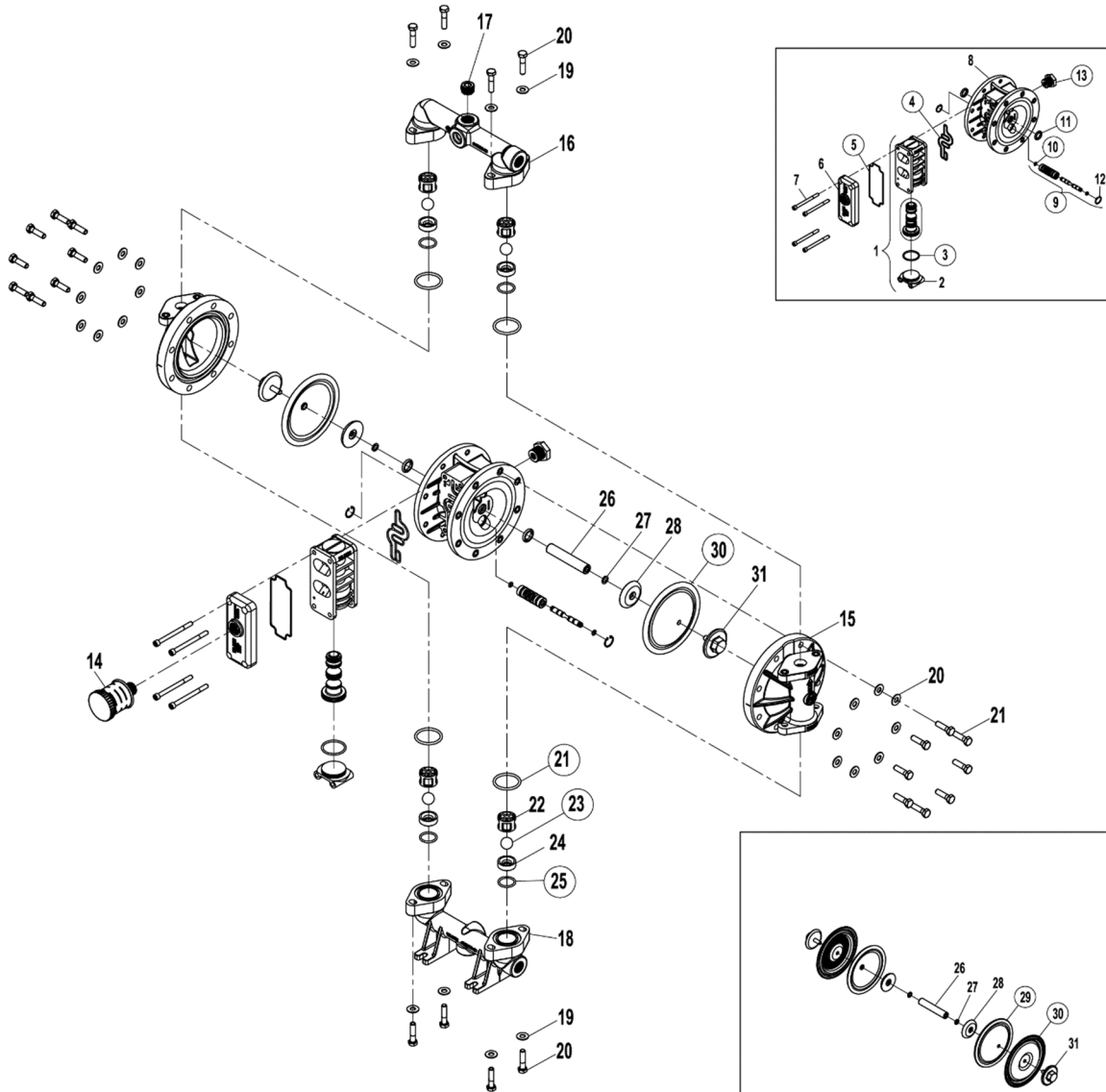

Exploded View and Parts List

Item	Part Description	Qty. Per Pump	P100/PPPPP/.../ P/N	P100/PPPPP/.../0502 P/N	P100/KKPPP/.../ P/N	P100/ KKPPP/.../0502 P/N
Air Distribution Components						
1	Air Valve Assembly, Pro-Flo™¹	1	01-2010-20			
2	End Cap	1	01-2332-20			
3	O-Ring (-126), End Cap (Ø1.362" x Ø.103")	1	01-2395-52			
4	Gasket, Air Valve, Pro-Flo™	1	01-2615-52			
5	Gasket, Muffler Plate, Pro-Flo™	1	01-3505-52			
6	Muffler Plate, Pro-Flo™	1	01-3181-20			
7	Screw, SHC, Air Valve (1/4"-20 x 3")	4	01-6001-03	01-6001-05	01-6001-03	01-6001-05
8	Center Section Assembly, Pro-Flo™ ²	1	01-3141-20			
9	Assembly, Pilot Sleeve	1	01-3880-99			
10	O-Ring (-009), Pilot Spool Retaining (Ø.208" x Ø.070")	2	04-2650-49-700			
11	Seal, Shaft	2	01-3220-55			
12	Retaining Ring	2	00-2650-03			
13	Bushing, Reducer, 1/2" MNPT to 1/4" FNPT	1	01-6950-20			
14	Muffler, 1/2" MNPT	1	02-3510-99			
Wetted Path Components						
15	Chamber, Liquid	2	01-5005-20		01-5005-21	
16	Manifold, Discharge (NPT)	1	01-5035-20		01-5035-21	
	Manifold, Discharge (BSPT)	1	01-5036-20		01-5036-21	
	Manifold, Discharge Center Ported (NPT)	1	01-5035-20-677		01-5035-21-677	
	Manifold, Discharge Center Ported (BSPT)	1	01-5036-20-678		01-5036-21-678	
	Manifold, Discharge Vertical Ported (NPT)	1			01-5035-21-672	
	Manifold, Discharge Vertical Ported (BSPT)	1	01-5036-20-673		01-5036-21-673	
17	Plug, 1/2" NPT	2	01-7010-20		01-7010-21	
18	Manifold, Inlet (NPT)	1	01-5095-20		01-5095-21	
	Manifold, Inlet (BSPT)	1	01-5096-20		01-5096-21	
	Manifold, Inlet Drum Pump (NPT only)	1	01-5094-20		01-5094-21	
	Manifold, OEM Inlet (NPT)	1	01-5097-20		01-5097-21	
	Manifold, OEM Inlet (BSPT)	1	01-5098-20		01-5098-21	
19	Washer, (.343 I.D. X .750 O.D. X .050 THK.)	24	01-6732-03	01-6732-05	01-6732-03	01-6732-05
20	Bolt, HHCS, 5/16"-18 X 1-3/8"	24	08-6100-03	01-6191-05	08-6100-03	01-6191-05
Valve Balls/Valve Seats/Valve O-Rings						
21	O-Ring, (-222) Manifold (Ø1.484 x Ø.139)	4	*			
22	Ball Cage	4	01-5355-20		01-5355-21	
23	Ball, Valve	4	*			
24	Seat, Valve	4	01-1125-20		01-1125-21	
25	O-Ring (-119), Valve Seat (Ø.924 x Ø.139)	4	*			
Rubber/TPE/PTFE/IPD Components						
26	Shaft	1	01-3810-03			
27	Spring, Disk (Ø.331" x Ø.512")	2	01-6802-08			
28	Piston, Inner	2	01-3711-08			
29	Diaphragm, Back-Up	2	*			
30	Diaphragm, Primary	2	*			
	Diaphragm, IPD Primary	2	*			
31	Piston, Outer	2	01-4570-20-500		01-4570-21-500	

LW0489 Rev. B

¹Air Valve Assembly includes items 2 and 3.
²Center Section Assembly includes item 11 and 13.
All boldface items are primary wear parts.

Section 9

Elastomer Options

P100 Plastic

Material	Diaphragm	IPD Diaphragms	Back-Up Diaphragms	Valve Balls	Valve Seats	Valve Seats O-Rings	Manifold O-Rings
Polyurethane	01-1010-50			01-1080-50		01-1200-50	02-1230-50
Neoprene			01-1060-51				
Buna-N	01-1010-52			01-1080-52		00-1260-52	02-1230-52
High Temp. Buna-N			01-1060-61				
FKM	01-1010-53			01-1080-53		01-1205-53	01-1370-53
PTFE	01-1010-55	01-1030-55		01-1080-55			
Saniflex™	01-1010-56			01-1080-56			
Wil-Flex™	01-1010-58			01-1080-58		00-1260-58	01-1370-58
PTFE Encapsulated/FKM						01-1205-60	05-1370-60
Polypropylene					01-1125-20		
PVDF					01-1125-21		

LW0489 Rev. B

Notes

Notes

Notes

PSG
22069 Van Buren Street
Grand Terrace, CA 92313-5651 USA
P: +1 (909) 422-1730 • F: +1 (909) 783-3440
psgdover.com



Where Innovation Flows