

BALDOR® • ***RELIANCE***

Product Information Packet

ECP62333TR-4

15HP,1760RPM,3PH,60HZ,254T,0944M,TEFC,F1

Part Detail							
Revision:	R	Status:	PRD/A	Change #:		Proprietary:	No
Type:	AC	Prod. Type:	0944M	Elec. Spec:	09WGZ997	CD Diagram:	CD0006
Enclosure:	TEFC	Mfg Plant:		Mech. Spec:	09K884	Layout:	09LYK884
Frame:	254T	Mounting:	F1	Poles:	04	Created Date:	09-17-2013
Base:	RG	Rotation:	R	Insulation:	F	Eff. Date:	01-26-2017
Leads:	3#12					Replaced By:	
Literature:		Elec. Diagram:					

Nameplate NP3201									
STK.NO.	ECP62333TR-4	P/N		ENCL	TEFC				
SPEC.	09K884Z997	CC	010A	FRAME	254T	S/N			
HP	15	CLASS	F	HZ	60	ODE BRG	6309	DE BRG	NU309
RPM	1760	RPM MAX	2700	PH	3	DES	B	D.E. BRG.	45RU03X30X
VOLT	460	CODE	G	O.D.E. BRG.	45BC03X30X				
AMP	17.6	MOTOR WEIGHT	324	GREASE	MOBILITH SHC220				
RATING	40C AMB-CONT	MAX. KVAR	3.5	BLANK	AIR COOLED HEAT				
NEMA-NOM-EFF	92.4	# OF ROTOR BARS	40	SER.F.	1.15	IP	56	EXCHANGER MTR	
G.MIN.EFF	91	# OF STATOR SLOTS	48	PF	85	INV.TYPE	PWM		
TEMP CODE	T3C	INVERTER-TEMP-CODE	180						
TEMP =	160	C HP FR	60	C HP TO	90				
CT HZ FROM	1.3	CT HZ TO	60						
HTR-VOLTS		HTR-AMPS		HTR-WATTS		MAX. SPACE HEATER TEMP.		VT HZ FROM	0
								VT HZ TO	60

Parts List		
Part Number	Description	Quantity
SA269254	SA 09K884Z997	1.000 EA
RA255906	RA 09K884Z997	1.000 EA
WD1000B16	T&B CX70TN TERMINAL	1.000 EA
10XN2520K06	1/4-20 X 3/8" HX HD SCREWGRADE 5, ZINC P	1.000 EA
HW1002A63	WASHER, 5/8 HI-COLLAR SPRLCKWASHER	1.000 EA
09CB1002A12P	KOBX W/1.25 NPT LEAD HOLE & 2.38 MTG HOL	1.000 EA
09GS1010	GASKET, DWG, LEADWIRE SEPERATOR	1.000 EA
10XN2520K12	1/4-20 X.75 GRD 5	4.000 EA
HW1001A25	LOCKWASHER 1/4, ZINC PLT .493 OD, .255 I	4.000 EA
WD1000B16	T&B CX70TN TERMINAL	1.000 EA
10XN2520K06	1/4-20 X 3/8" HX HD SCREWGRADE 5, ZINC P	1.000 EA
HW1001A25	LOCKWASHER 1/4, ZINC PLT .493 OD, .255 I	1.000 EA
HA3400A39	STUD- 3/8-16 X 6.19 OAL HEX WELKER	4.000 EA
HW1001A38	LOCKWASHER 3/8, ZINC PLT .688 OD, .382 I	4.000 EA
HW4601A61	INPRO SEAL #1698-A-17120-0, VBXX 309 BRG	1.000 EA
HW4500A20	1/8NPT SL PIPE PLUG	1.000 EA
HA4017A08	.125X3.50 GREASER EXTEN.	1.000 EA
HA4017A02	.125X2.50 GREASER EXTENS.F/S	1.000 EA
HW4019A01	PIPE COUPLING 1/8 NPT,STEEL,ZINC COATING	1.000 EA
HW4601A61	INPRO SEAL #1698-A-17120-0, VBXX 309 BRG	1.000 EA
10XN2520K36	1/4-20 X 2.25" HX HD SCRWGRADE 5, ZINC P	4.000 EA
HW4600G53	DOME SLINGER, 5.438 OD X 1.620/1.562 ID	1.000 EA
09EP1118A121P	PUEP W/309 BRG, INPRO & EPOXY PRIMER	1.000 EA
HW4500A20	1/8NPT SL PIPE PLUG	1.000 EA

Parts List (continued)		
Part Number	Description	Quantity
10XN3816K28	3/8-16 X 1.75 HEX HD CAP SCREW, GRADE 5	4.000 EA
HW1001A38	LOCKWASHER 3/8, ZINC PLT .688 OD, .382 I	4.000 EA
10XN2520K36	1/4-20 X 2.25" HX HD SCRWGRADE 5, ZINC P	4.000 EA
XY3816A12	3/8-16 FINISHED NUT	4.000 EA
HW1001A38	LOCKWASHER 3/8, ZINC PLT .688 OD, .382 I	4.000 EA
WD4100A08	HEYCO #2783 DOME PLUG DP-2000(CUSTOME	1.000 EA
12CB1503A01P	KOLD MACH, W/LIP & EPOXY PRIMER	1.000 EA
12GS1002	GASKET, CONDUIT BOX LID, NEOP	1.000 EA
10XN3118K16	5/16-18 X 1' GRADE #5, STL, ZINC PLATE	2.000 EA
HW1001A31	LOCKWASHER 5/16, ZINC PLT.591 OD, .319 I	2.000 EA
MJ5004A59	ADHESIVE LOCTITE #401 SURFACE INSENSITIV	0.010 EA
HW2501G25	KEY, 3/8 SQ X 2.875	1.000 EA
MJ5001A27	32220KN GRAY SEALER *MIN BUY 4 QTS=1GAL	0.031 QT
MJ5001A14	DYNAPRO SEAL, CP MOTORS VC#2508050 (603	0.023 EA
LB1115N	LABEL,LIFTING DEVICE (ON ROLLS)	1.000 EA
MN416A01	TAG-INSTAL-MAINT no wire (1000/bx) 11/14	1.000 EA
WD1000B49	T&B C73,RING TERMINAL 10-12 AWG 3/8 STUD	3.000 EA
09EP1118A121GP6	FREP MACH, 309 BRG. EPOXY & MG1025N19	1.000 EA
HW4500A21	1618BALEMITE FITTING 825 UNIVERSAL	1.000 EA
HA4051A00	PLASTIC CAP FOR GREASE FITTING	1.000 EA
HW4500A17	317400 ALEMITE GREASE RELIEF	1.000 EA
HA4002A01	DRAIN PLUG STAINLESS STL	1.000 EA
MJ1000A62	GREASE - MOBILITH SHC220, HC9455	0.080 LB
HW4500A03	GREASE FITTING, .125 NPT 1610(ALEMITE) 8	1.000 EA

Product Information Packet: ECP62333TR-4 - 15HP,1760RPM,3PH,60HZ,254T,0944M,TEFC,F1

HA4051A00	PLASTIC CAP FOR GREASE FITTING	1.000 EA
HW4500A17	317400 ALEMITE GREASE RELIEF	1.000 EA
HA4002A01	DRAIN PLUG STAINLESS STL	1.000 EA
09FN3001D01	EXTERNAL FAN, PLASTIC	1.000 EA
HW2500A25	WOODRUFF KEY USA #1008 #BLOW CARBON STEE	1.000 EA
51XB1214A20	12-14X1.25 HXWSSLD SERTYB	1.000 EA
09FH1000A74GP6	FAN HSG, W/EPOXY, 2.00 BORE W/MG1025N19	1.000 EA
MG1025N19	WILKOFEST, 778.50, RELIANCE BLUE-GREEN	0.050 GA
85XU0407S04	4X1/4 U DRIVE PIN STAINLESS	4.000 EA
LB1449	DIV-2/NEC WARNING LABEL	1.000 EA
LB1119N	WARNING LABEL	1.000 EA
LC0006	CONNECTION LABEL	1.000 EA
NP3201	SS IEEE661 INV DIV-2 UL CSA- C US EEV	1.000 EA
40PA1005	PACKAGING GROUP, 09 STD	1.000 EA
09PA1061	PKGP SHAFT TENSIONER 2X4 4-3/4 LEG 4-1/2	1.000 EA

AC Induction Motor Performance Data

Record # 47086 - Typical performance - not guaranteed values

Winding: 09WGZ997-R019	Type: 0944M	Enclosure: TEFC
-------------------------------	--------------------	------------------------

Nameplate Data				460 V, 60 Hz: Single Voltage Motor	
Rated Output (HP)	15			Full Load Torque	44.6 LB-FT
Volts	460			Start Configuration	direct on line
Full Load Amps	17.6			Breakdown Torque	163 LB-FT
R.P.M.	1760			Pull-up Torque	53.3 LB-FT
Hz	60	Phase	3	Locked-rotor Torque	73.2 LB-FT
NEMA Design Code	B	KVA Code	G	Starting Current	108 A
Service Factor (S.F.)	1.15			No-load Current	6.19 A
NEMA Nom. Eff.	92.4	Power Factor	85	Line-line Res. @ 25°C	0.62 Ω
Rating - Duty	40C AMB-CONT			Temp. Rise @ Rated Load	50°C
S.F. Amps				Temp. Rise @ S.F. Load	62°C
				Locked-rotor Power Factor	32.7
				Rotor inertia	1.92 LB-FT ²

Load Characteristics 460 V, 60 Hz, 15 HP

% of Rated Load	25	50	75	100	125	150	S.F.
Power Factor	52	73	84	86	87	88	87
Efficiency	89.4	92.6	93	92.5	91.4	90.3	91.9
Speed	1792	1783	1773	1763	1752	1739	1756
Line amperes	7.44	10.3	13.5	17.6	22	26.6	20.2

Performance Graph at 460V, 60Hz, 15.0HP Typical performance - Not guaranteed values

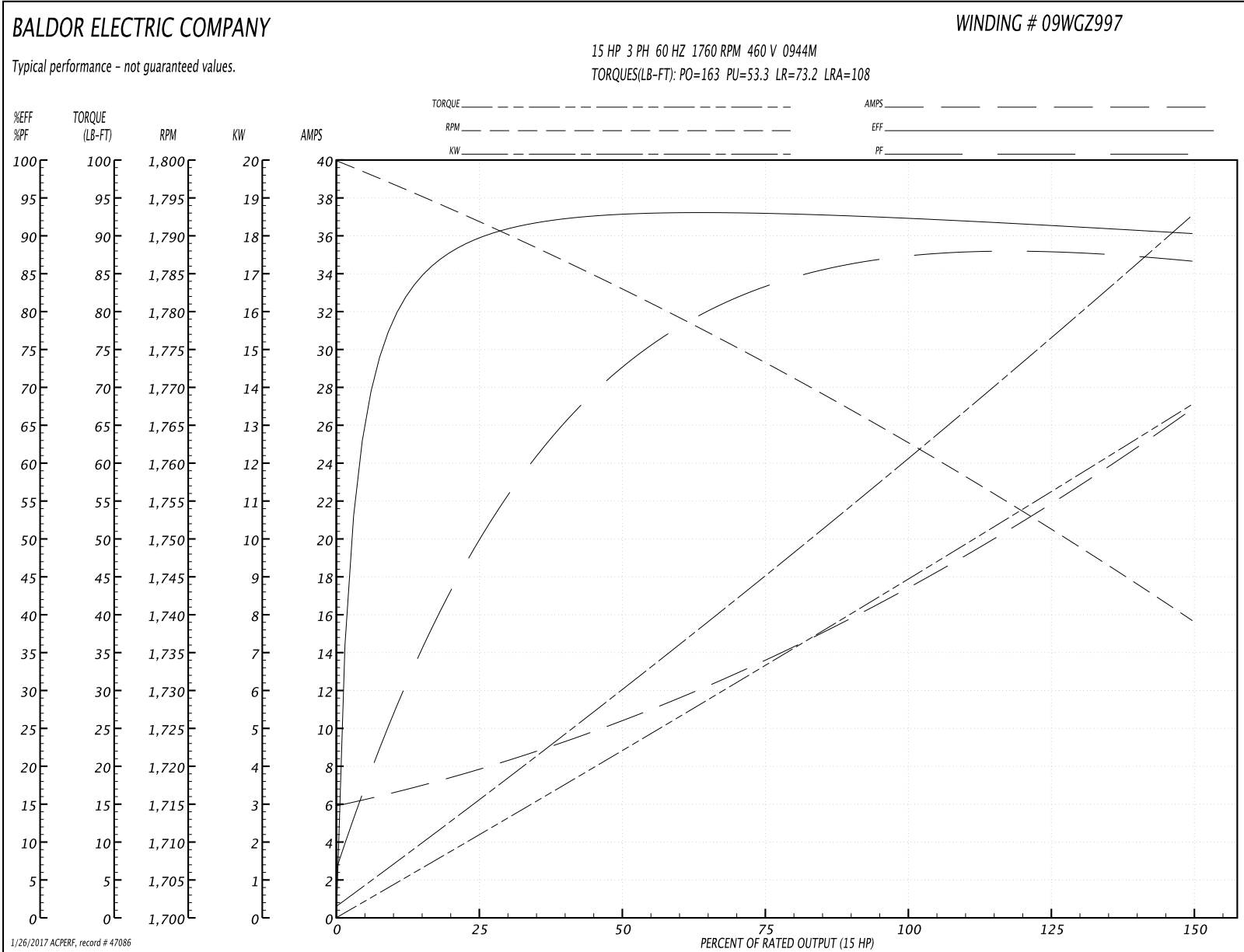

CD0006

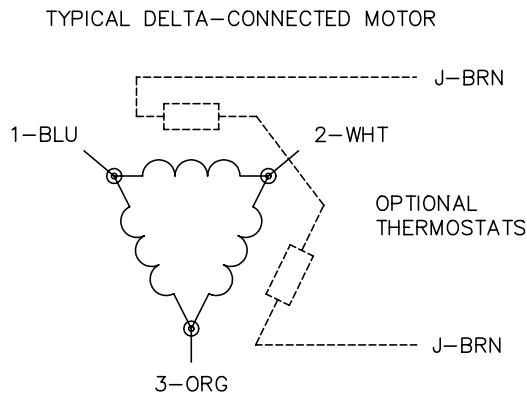

NOTES:

1. THREE LEAD MOTOR MAY BE EITHER WYE CONNECTED OR DELTA CONNECTED.
2. INTERCHANGE ANY TWO LINE LEADS TO REVERSE ROTATION.
3. OPTIONAL THERMOSTATS ARE PROVIDED WHEN SPECIFIED.
4. ACTUAL NUMBER OF INTERNAL PARALLEL CIRCUITS MAY VARY.
5. LEAD COLORS ARE OPTIONAL. LEADS MUST BE NUMBERED AS SHOWN.

REV. DESC: REVISE TO SHOW OPTIONAL COLORS			
REV. LTR: D	BY: JLP	REVISED: 01/21/99 4:02	TDR: 0171435
9000D		FILE: AAA00005141	MDL: -
		MTL: -	

BALDOR ELECTRIC Co.

3PH, SV, 3 LEADS, WYE OR DELTA CONNECTED

CD0006

Marketing maintained PDF of MN416:

<http://www.baldor.com/support/Literature/Load.ashx/MN416?ManNumber=MN416>