

BALDOR® • **RELIANCE**

Product Information Packet

EFM2539T

40HP, 1770RPM, 3PH, 60HZ, 324T, 4064M, OPSB, F2

Part Detail							
Revision:	Q	Status:	PRD/A	Change #:		Proprietary:	No
Type:	AC	Prod. Type:	4064M	Elec. Spec:	40WGX166	CD Diagram:	CD0005
Enclosure:	OPSB	Mfg Plant:		Mech. Spec:	40H24	Layout:	40LYH024
Frame:	324T	Mounting:	F2	Poles:	04	Created Date:	10-25-2010
Base:	RG	Rotation:	R	Insulation:	F	Eff. Date:	01-13-2017
Leads:	9#8					Replaced By:	
Literature:		Elec. Diagram:					

Nameplate NP3554L											
CAT.NO.	EFM2539T			P/N				ENCLOSURE	OPSB		
SPEC.	40H024X166G1		CC	010A	FRAME	324T		S/N			
HP	40			CLASS	F	HZ	60				
RPM	1770			PH	3	DES	A				
VOLT	230/460			KVA-CODE	H		ODE BRG	6309		DE BRG	6312
AMP	98/49			USABLE AT 208V		99					
RATING	40C AMB-CONT			NEMA-NOM-EFF		94.1		GREASE POLYREX EM			
PF	82	SER.F.	1.15		VPWM INVERTER READY						
HTR-VOLTS			HTR-AMPS			MAX. SPACE HEATER TEMP.					

Parts List		
Part Number	Description	Quantity
SA205010	SA 40H024X166G1	1.000 EA
RA192257	RA 40H024X166G1	1.000 EA
S/P107-000-004	SUPER-E(284 FR. & UP)-CL PLANT,POLYREX E	1.000 EA
HA6361A01	LIFTING LUG FOR 37, 39 & 40 FRAME ZINC	2.000 EA
HA6017	CAST ADAPTER, 40,42 KOBX	1.000 EA
19XW3118A12	.31-18 X .75 HEX WASHER HEAD TAPTITE II	2.000 EA
HW1001A31	LOCKWASHER 5/16, ZINC PLT.591 OD, .319 I	2.000 EA
10CB3001	CONDUIT BOX CAST W/2.500 LEAD HOLE	1.000 EA
19XW3118A12	.31-18 X .75 HEX WASHER HEAD TAPTITE II	4.000 EA
HW1001A31	LOCKWASHER 5/16, ZINC PLT.591 OD, .319 I	4.000 EA
WD1000B16	T&B CX70TN TERMINAL	1.000 EA
51XF2520A08	SCREW, HEX SER SLT HD, ZN 1/4-20 X .50 L	1.000 EA
40EP3200A02	STD FREP OPEN 309 BRG	1.000 EA
HW5100A11	W3917-042 WVY WSHR (WB)	1.000 EA
40EP3201A01	PU ENDPLATE, MACH - OPEN - FOR 312 BRG	1.000 EA
XY3816A12	3/8-16 FINISHED NUT	8.000 EA
10CB3500SP	CONDUIT BOX LID, CAST	1.000 EA
51XW2520A12	.25-20 X .75, TAPTITE II, HEX WSHR SLTD	4.000 EA
HW2501H33	KEY, 1/2 SQ X 3.875	1.000 EA
LB1115N	LABEL,LIFTING DEVICE (ON ROLLS)	1.000 EA
MN416A01	TAG-INSTAL-MAINT no wire (1000/bx) 11/14	1.000 EA
HW4500A03	GREASE FITTING, .125 NPT 1610(ALEMITE) 8	1.000 EA
HW4500A20	1/8NPT SL PIPE PLUG	1.000 EA
HA4051A00	PLASTIC CAP FOR GREASE FITTING	1.000 EA

Parts List (continued)		
Part Number	Description	Quantity
MJ1000A02	GREASE, POLYREX EM EXXON (USe 4824-15A)	0.050 LB
HW4500A03	GREASE FITTING, .125 NPT 1610(ALEMITE) 8	1.000 EA
HW4500A20	1/8NPT SL PIPE PLUG	1.000 EA
HA4051A00	PLASTIC CAP FOR GREASE FITTING	1.000 EA
MG1000Y03	MUNSELL 2.53Y 6.70/ 4.60, GLOSS 20,	0.030 GA
85XU0407S04	4X1/4 U DRIVE PIN STAINLESS	4.000 EA
40AD2002A01	LEXAN BAFFLE 40 FR OPEN	1.000 EA
40AD2002A01	LEXAN BAFFLE 40 FR OPEN	1.000 EA
HA3154A06	THRUBOLT STUD 3/8-16 X 19.500	4.000 EA
LC0005E02	SPL CONN.DIA./WARN.LABEL(LC0005/LB1119)	1.000 EA
NP3554L	SS SUPER-E UL CSA-EEV PREM CC	1.000 EA
40PA1000	PACKAGING GROUP	1.000 EA

Accessories		
Part Number	Description	Multiplier
42-1300	C FACE KIT	A8
42EP1601A01	SP'L D-FLANGE MTD. PU. E.P. MDL.42 W/BFL	P1

AC Induction Motor Performance Data

Record # 31313 - Typical performance - not guaranteed values

Winding: 40WGX166-R002	Type: 4064M	Enclosure: OPSB
-------------------------------	--------------------	------------------------

Nameplate Data				460 V, 60 Hz: High Voltage Connection	
Rated Output (HP)	40			Full Load Torque	119 LB-FT
Volts	230/460			Start Configuration	direct on line
Full Load Amps	98/49			Breakdown Torque	427 LB-FT
R.P.M.	1770			Pull-up Torque	187 LB-FT
Hz	60	Phase	3	Locked-rotor Torque	246 LB-FT
NEMA Design Code	A	KVA Code	H	Starting Current	330 A
Service Factor (S.F.)	1.15			No-load Current	21.1 A
NEMA Nom. Eff.	94.1	Power Factor	82	Line-line Res. @ 25°C	0.16236 Ω
Rating - Duty	40C AMB-CONT			Temp. Rise @ Rated Load	41°C
S.F. Amps				Temp. Rise @ S.F. Load	51°C
				Locked-rotor Power Factor	32
				Rotor inertia	5.09 LB-FT ²

Load Characteristics 460 V, 60 Hz, 40 HP

% of Rated Load	25	50	75	100	125	150	S.F.
Power Factor	43	65	76	82	85	85	84
Efficiency	91.1	94	94.5	94.2	93.6	92.8	93.8
Speed	1792.4	1785	1777.8	1770.2	1762.1	1752.8	1765
Line amperes	24.1	30.7	39.2	48.7	59.3	71.3	55.1

Performance Graph at 460V, 60Hz, 40.0HP Typical performance - Not guaranteed values

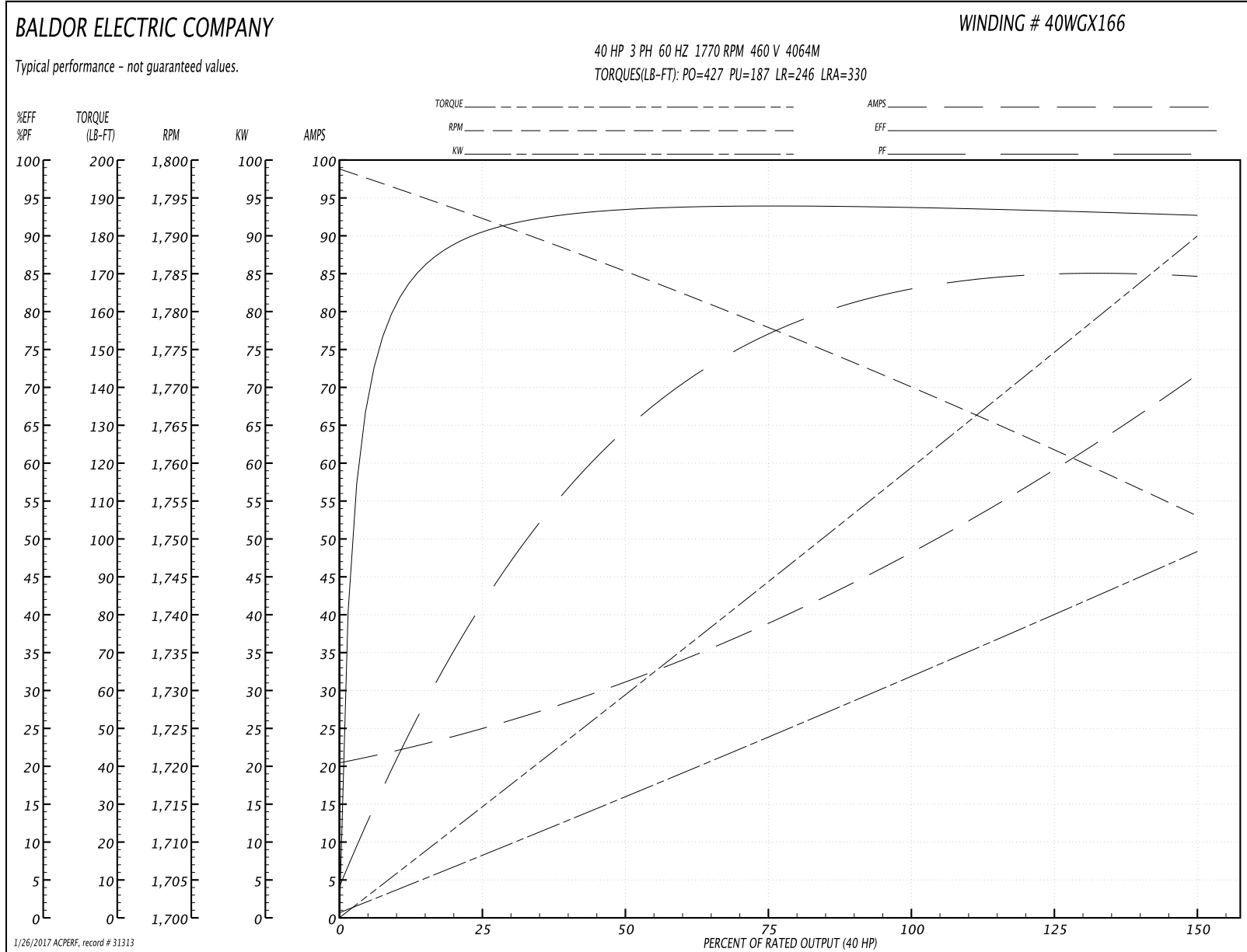

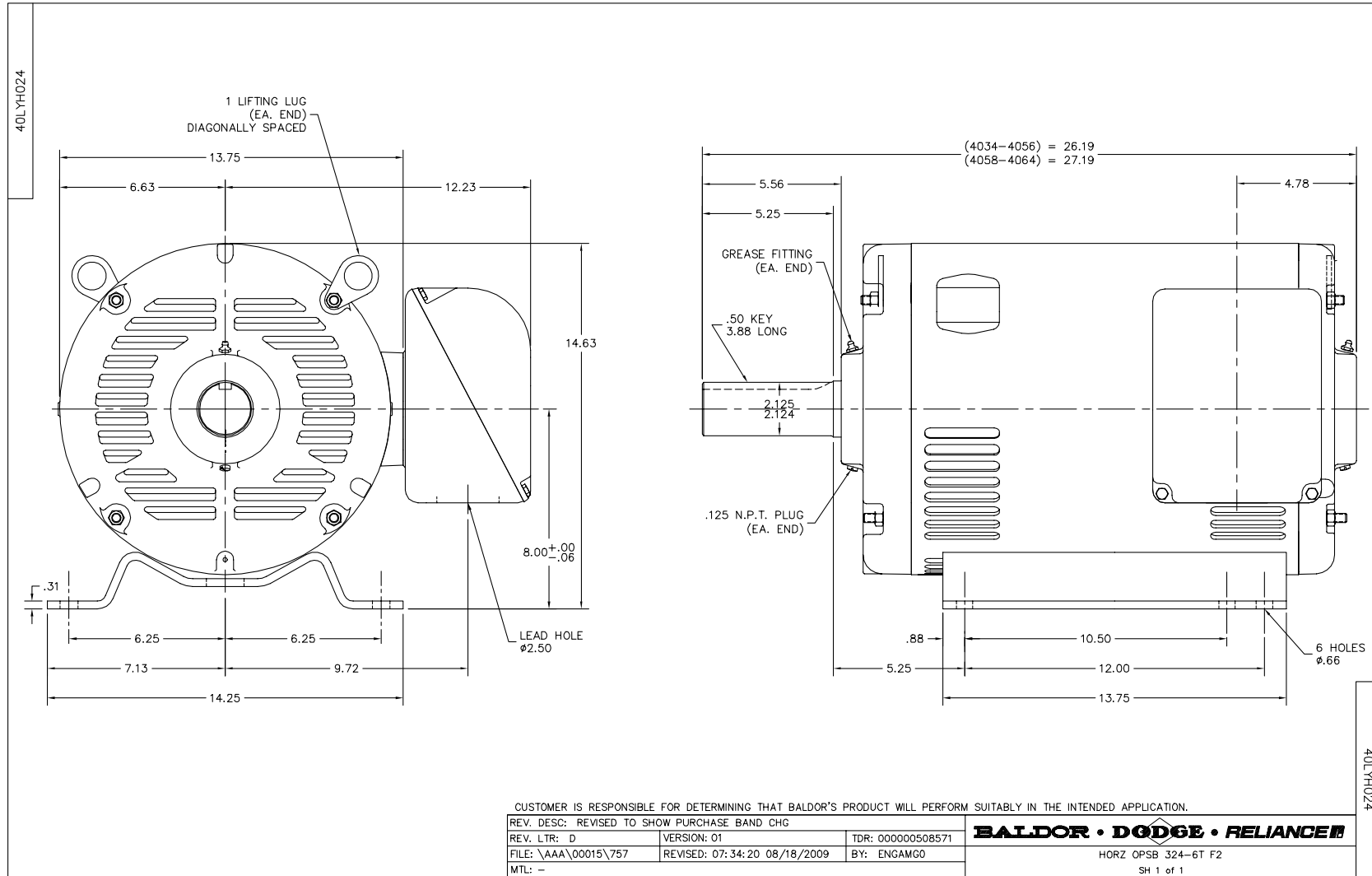

CD0005



LOW VOLTAGE
(2Y)



LINE

HIGH VOLTAGE
(1Y)



LINE

NOTES:

1. INTERCHANGE ANY TWO LINE LEADS TO REVERSE ROTATION.
2. OPTIONAL THERMOSTATS ARE PROVIDED WHEN SPECIFIED.
3. ACTUAL NUMBER OF INTERNAL PARALLEL CIRCUITS MAY BE A MULTIPLE OF THOSE SHOWN ABOVE.
4. LEAD COLORS ARE OPTIONAL. LEADS MUST ALWAYS BE NUMBERED AS SHOWN.

REV. DESC: REVISE TO SHOW OPTIONAL COLORS			
REV. LTR: E	BY: JLP	REVISED: 01/19/99 10:15	TDR: 0171435
900003		FILE: AAA00005140	MDL: -
		MTL: -	

BALDOR ELECTRIC Co.

3PH, DV, 9 LEADS

CD0005