



TECHNICAL BROCHURE

BeSV50 R2

e-SV™ 50 Hz Technical Manual

E-SV SERIES VERTICAL MULTI-STAGE PUMPS

 **GOULDS**
WATER TECHNOLOGY
a xylem brand

Contents

Coverage Curves	4
General Market Specifications	5
Characteristics of 1-125SV Series	6
Characteristics of 33-92SV Series	6
General Characteristics	7
Typical Applications of e-SV Pumps	8
e-SV Nomenclature	9-12
1-22SV Series Pump Cross Section and Major Components	13-14
33-92SV Series Pump Cross Section and Major Components	15-16
125SV Series Pump Cross Section and Major Components	17-18
e-SV Mechanical Seals	19
Maximum Allowable Working Pressure Charts	20
Maximum Inlet Pressure	21
Motor Data	21-23
2900 RPM Curves, Dimensions and Weights	24-45
1450 RPM Curves, Dimensions and Weights	46-67
Horizontal Mounting Options	68-71
Table of Hydraulic Performances at 2900 RPM	72-77
Table of Hydraulic Performances at 1450 RPM	78-83
Technical Appendix	84-86

e-SV Rating Plate

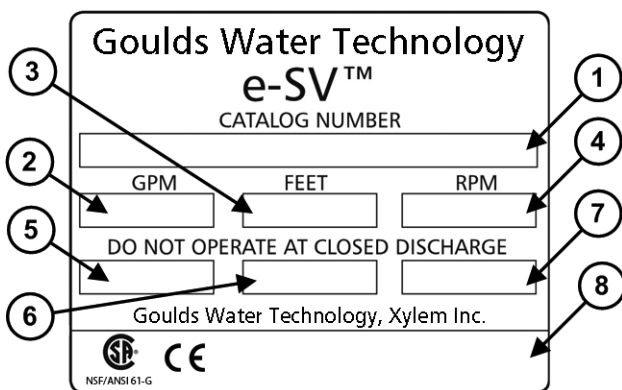

1	Goolds Catalog Number
2	Capacity Range
3	TDH Range
4	Rated Speed
5	Rated Horsepower
6	Maximum Operating Pressure
7	Maximum Operating Temperature
8	Pump Serial Number

e-SV Coverage Curve

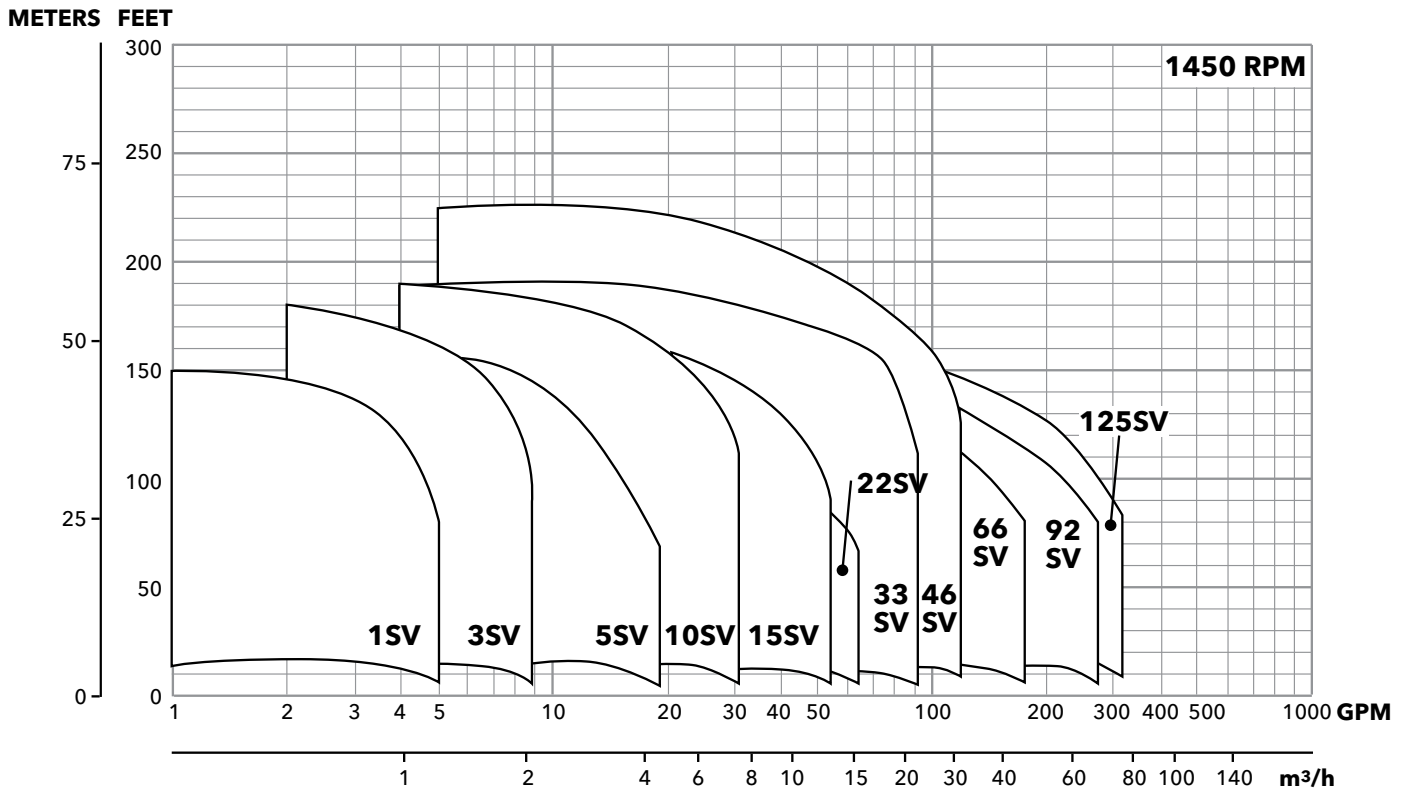
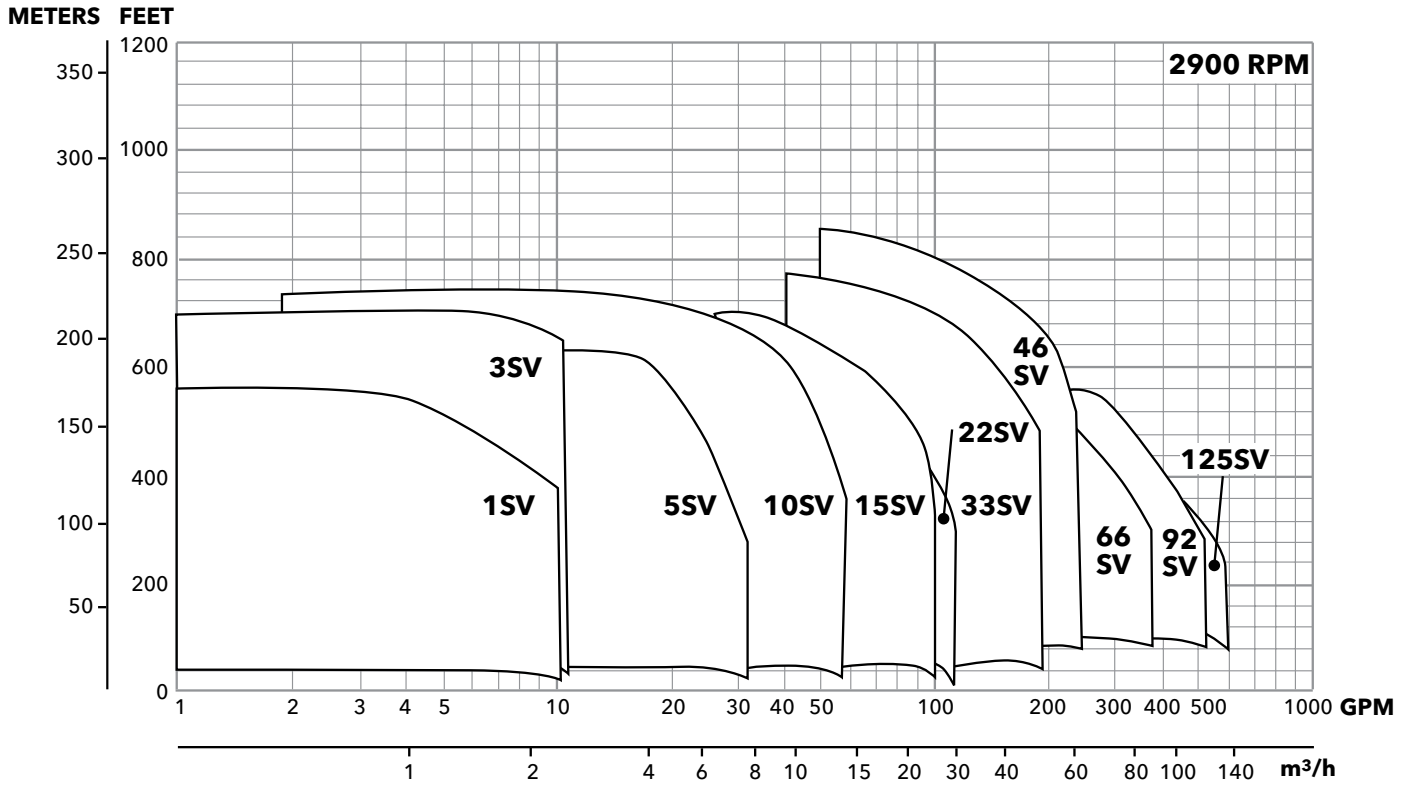

e-SV General Market Specifications

MUNICIPAL, AGRICULTURAL, LIGHT INDUSTRY,
WATER TREATMENT, HEATING AND AIR CONDITIONING

Applications

- Handling of water, free of suspended solids, in the municipal, industrial and agricultural markets
- Pressure boosting and water supply systems
- Fire fighting jockey pumps
- Irrigation systems
- Wash systems
- Water treatment plants: reverse osmosis
- Handling of moderately aggressive liquids, demineralized water, water and glycol, etc.
- Circulation of hot and cold water for heating, cooling and conditioning systems
- Boiler feed

Specifications

PUMP

The e-SV pump is a non-self priming vertical multistage pump coupled to a standard motor.

The liquid end, located between the upper cover and the pump casing, is held in place by tie rods. The pump casing is available with different configurations and connection types.

- Delivery: up to 160 m³/hr (700 GPM)
- Head: up to 250 m (850 feet)
- Temperature of pumped liquid:
 - 20°F to 250°F (-30°C to 120°C) standard version
- Optional temperature range up to 300°F (149°C) high temperature version
- Maximum operating pressure
 - SV1-22 with oval flanges: 230 PSI (16 bar)
 - SV1-22 with round flanges or Victaulic: 360 or 575 PSI (25 or 40 bar)
 - SV33, 46: 360 or 580 PSI (25 or 40 bar)*
 - SV 66, 92: 360 or 580 PSI (25 or 40 bar)*
 - SV 125: 360 or 580 PSI (25 or 40 bar)
- Direction of rotation: clockwise looking at the pump from the top down (marked with an arrow on the adapter and on the coupling).

MOTOR

- Standard NEMA TC Frame motors in open drip proof or totally enclosed fan cooled.
- 2900 RPM nominal
- Standard voltage:
 - Single phase version: 115-208/230 V, 50 Hz up to 2 HP or 208-230 V for 3 HP
 - Three phase version, 2 pole: 208-230/460 V, 50 Hz up 60 HP

* Based on pump staging

e-SV Characteristics

1SV, 3SV, 5SV, 10SV, 15SV, 22SV Series

- Vertical multistage centrifugal pump. All metal parts in contact with the pumped liquid are made of stainless steel.
- The following versions are available:
 - F - ANSI flanges, in-line delivery and suction ports, AISI 304
 - T - Oval flanges (NPT), in-line delivery and suction ports, AISI 304
 - R - ANSI flanges, delivery port above the suction port, with four adjustable positions, AISI 304
 - N - ANSI flanges, in-line delivery and suction ports, AISI 316
 - P - Victaulic couplings, in-line delivery and suction ports, AISI 316
 - G - ANSI flange, in-line delivery and suction ports, Class 35/40B cast iron.
 - C - ISO clamp, AISI 316
- Innovative axial load compensation system on pumps with higher head. This ensures reduced axial thrusts and enables the use of standard NEMA TC motors that are easily found in the market.
- Seal housing chamber designed to prevent the accumulation of air in the critical area next to the mechanical seal
- Mechanical seal according to EN 12756 (ex DIN 24960) and ISO 3069
- Versions with ANSI flanges that can be coupled to ANSI raised face counter-flanges
- Threaded oval counter-flanges made of stainless steel are standard supply for the T versions
- Easy maintenance. No special tools required for assembly or disassembly
- Standard version for temperatures ranging from: -20°F to 250°F (30°C to 120°C)

33SV, 46SV, 66SV, 92SV, 125SV Series

- Vertical multistage centrifugal pump with impellers, diffusers and outer sleeve made entirely of stainless steel, and with pump casing and motor adapter made of cast iron in the standard version
- Rotating components made entirely of AISI 316 stainless steel
- High heads and capacities five sizes: 33SV, 46SV, 66SV, 92SV, 125SV
- Re-designed liquid end provides improved efficiency and energy savings
- Innovative axial load compensation system on pumps with higher head. This ensures reduced axial thrusts and enables the use of standard NEMA TC motors that are easily found in the market.
- Balanced mechanical seal according to EN 12756 (ex DIN 24960) and ISO 3069, which can be replaced without removing the motor from the pump
- Seal housing chamber designed to prevent the accumulation of air in the critical area next to the mechanical seal
- Standard version for temperature ranging from: -20°F to 250°F (-30°C to 120°C)
- Pump body fitted with taps for installing pressure gauges on both suction and delivery flanges
- In-line ports with ANSI flanges that can be coupled to counter-flanges, in compliance with ANSI raised face.
- Mechanical sturdiness and easy maintenance. No special tools required for assembly or disassembly.

Optional Features

- Horizontal version
- Special voltages, 50 Hz frequency
- Special materials for the mechanical seal, gaskets and elastomers
- Tropicalized motors
- Premium E and explosion proof motors
- 1450 RPM, 4 pole motors
- Passivation

Commercial Water

General Characteristics - 2-pole

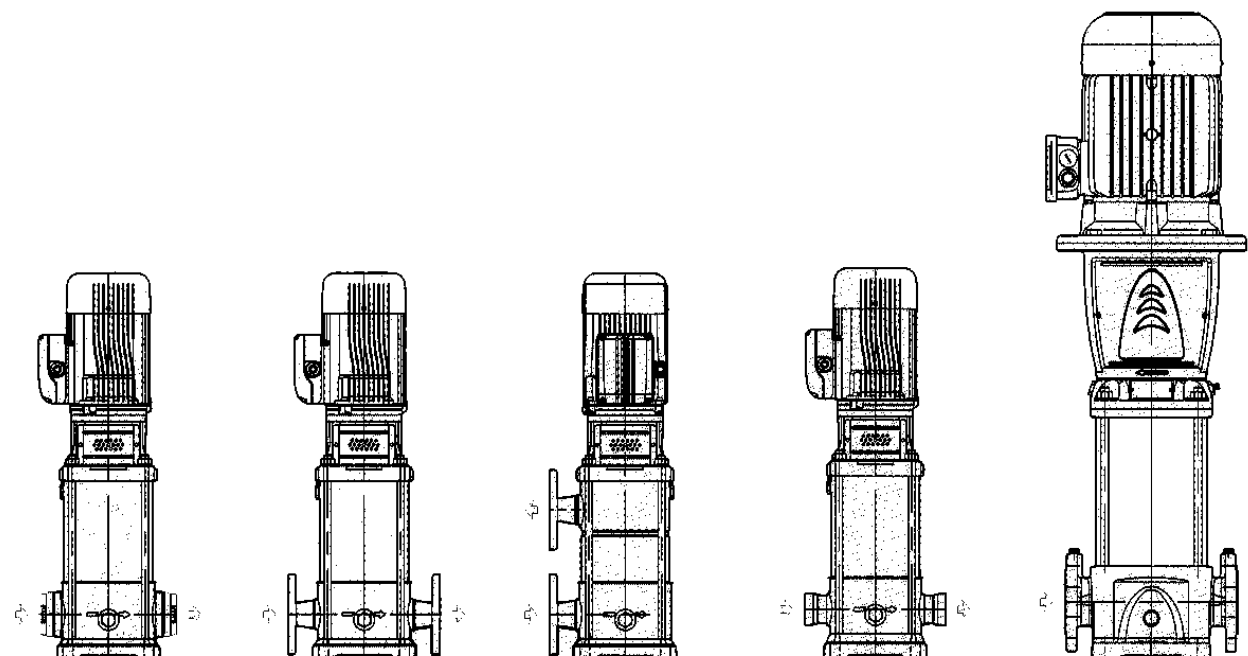

SERIES SVT
1SV, 3SV, 5SV,
10SV, 15SV, 22SV

SERIES SVF, SVN
1SV, 3SV, 5SV,
10SV, 15SV, 22SV

SERIES SVR
1SV, 3SV, 5SV,
10SV, 15SV, 22SV

SERIES SVP
VICTAULIC
1SV, 3SV, 5SV,
10SV, 15SV, 22SV

SERIES SVG, SVN
33SV, 46SV, 66SV,
92SV, 125SV

e-SV Product Range	1SV	3SV	5SV	10SV	15SV	22SV	33SV	46SV	66SV	92SV	125SV
Nominal Flow (GPM)	9	15	30	50	80	110	150	220	350	450	600
Flow Range (GPM)	2-12	3-22	7-45	9-75	18-125	21-150	30-195	45-285	70-420	90-580	120-700
Max. Head (Ft)	860	1085	975	1150	1060	880	1125	1210	850	715	570
Max. Working Pressure (PSIG)	580					360/580					
Temperature Range (°F)	Standard -20°F - 250°F (-30°C - 121°C)										
High Temp Option	up to 300°F (150°C)						-				
Motor Power [HP]	½ - 5 HP	½ - 7½	¾ - 10	¾ - 20	2 - 25	3 - 30	3 - 60	7½ - 75	10 - 75	15 - 75	20 - 75
Max Pump Efficiency	51%	60%	70%	70%	70%	71%	76%	78%	78%	80%	79%
Materials of Construction											
SVT	304 SS					-					
SVF	304 SS					-					
SVN	316L SS					Cast Stainless Steel / 316L SS					
SVR	304 SS					-					
SVP	316L SS					-					
SVC	316L SS					-					
SVG	ASTM Class 35/40B Cast Iron / 304 SS										
Connection Sizes											
SVT - Oval NPT	1¼"	1¼"	1¼"	2"	2"	2"	-				
SVF - Round ANSI Size/Class	1¼" 300#	1¼" 300#	1¼" 300#	2" 300#	2" 300#	2" 300#	-				
SVN - Round ANSI Size/Class	1¼" 300#	1¼" 300#	1¼" 300#	2" 300#	2" 300#	2" 300#	2½" 150/300#	3" 150/300#	4" 150/300#	4" 150/300#	5" 150/300#
SVR - Top/Bottom Round ANSI Size/Class	1¼" 300#	1¼" 300#	1¼" 300#	2" 300#	2" 300#	2" 300#	-				
SVP - Victaulic	1¼"	1¼"	1¼"	2"	2"	2"	-				
SVC - Clamp	1½"	1½"	1½"	2"	2"	2"	-				
SVG - Cast Iron Size/Class	1¼" 250#	1¼" 250#	1¼" 250#	2" 250#	2" 250#	2" 250#	2½" 125/250#	3" 125/250#	4" 125/250#	4" 125/250#	5" 125/250#

Commercial Water

Typical Applications of e-SV Series Multi-Stage Pumps

Water Supply and Pressure Boosting

- Pressure boosting in buildings, hotels, residential complexes
- Pressure booster stations, supply of water networks
- Booster packages

Water Treatment

- Ultra filtration systems
- Reverse osmosis systems
- Water softeners and de-mineralization
- Distillation systems
- Filtration

Light Industry

- Washing and cleaning plants (washing and degreasing of mechanical parts, car and truck wash tunnels, washing of electronic industry circuits)
- Commercial washers
- Fire fighting system pumps

Irrigation and Agriculture

- Greenhouses
- Humidifiers
- Sprinkler irrigation

Heating, Ventilation and Air Conditioning (HVAC)

- Cooling towers and systems
- Temperature control systems
- Refrigerators
- Induction heating
- Heat exchangers
- Boilers
- Water recirculation and heating

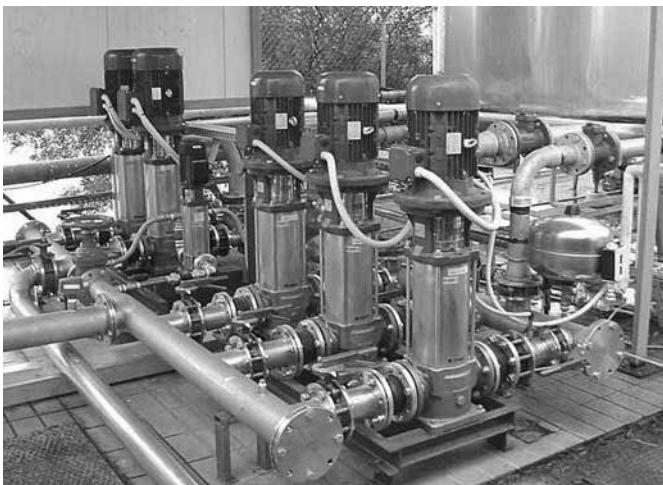

e-SV Product Line Numbering System for 1 - 22SV Liquid End Only

The various versions of the e-SV line are identified by a product code number on the pump label. This number is also the catalog number for the pump. The meaning of each digit in the product code number is shown below.
Note: Not all combinations are possible.

Example Product Code

22 SV 0 2 F E 3 0

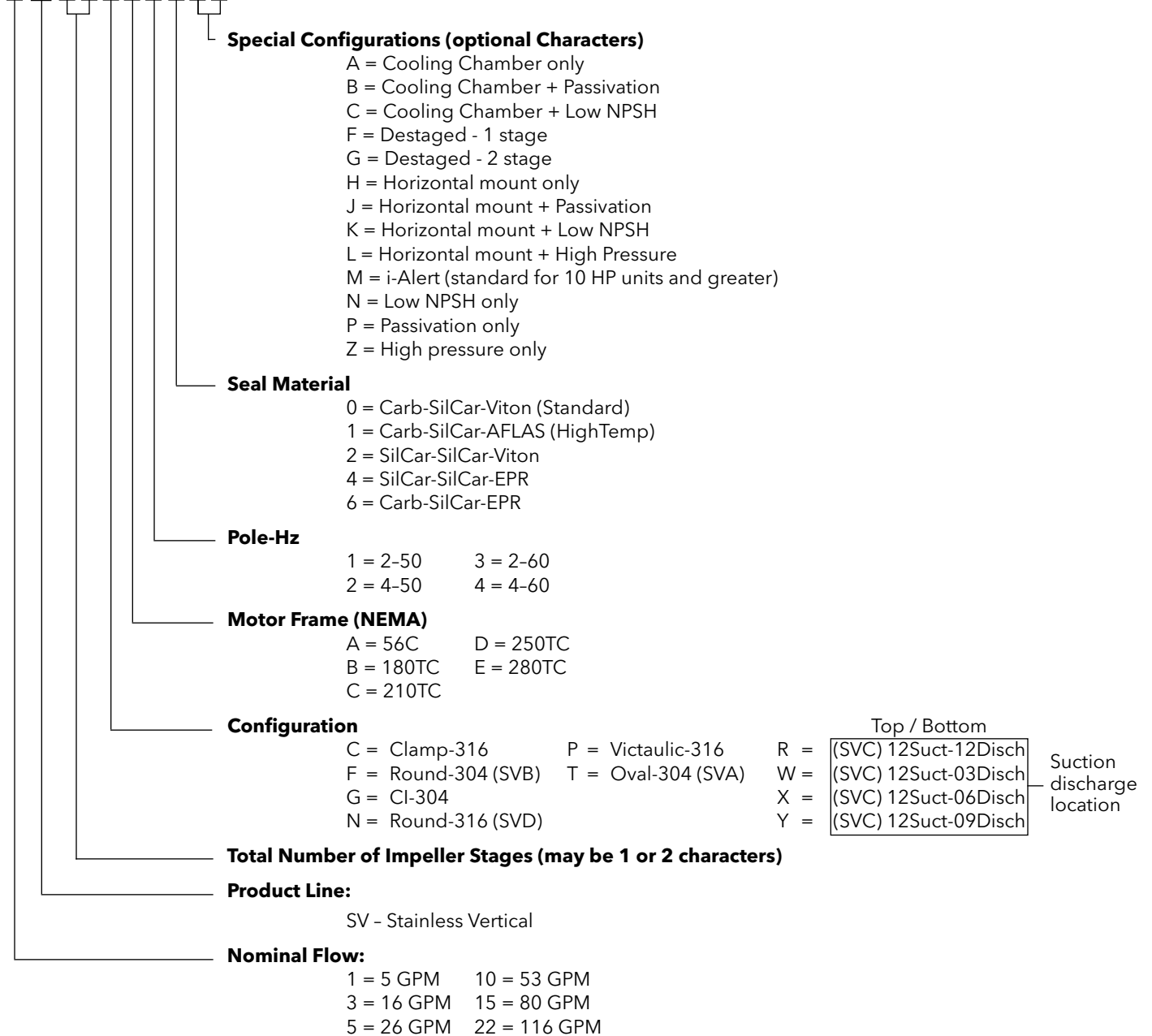

e-SV Product Line Numbering System for 33 - 125SV Liquid End Only

The various versions of the e-SV line are identified by a product code number on the pump label. This number is also the catalog number for the pump. The meaning of each digit in the product code number is shown below.

Note: Not all combinations are possible.

Example Product Code

125 SV 8 1 2 B F E 2 0

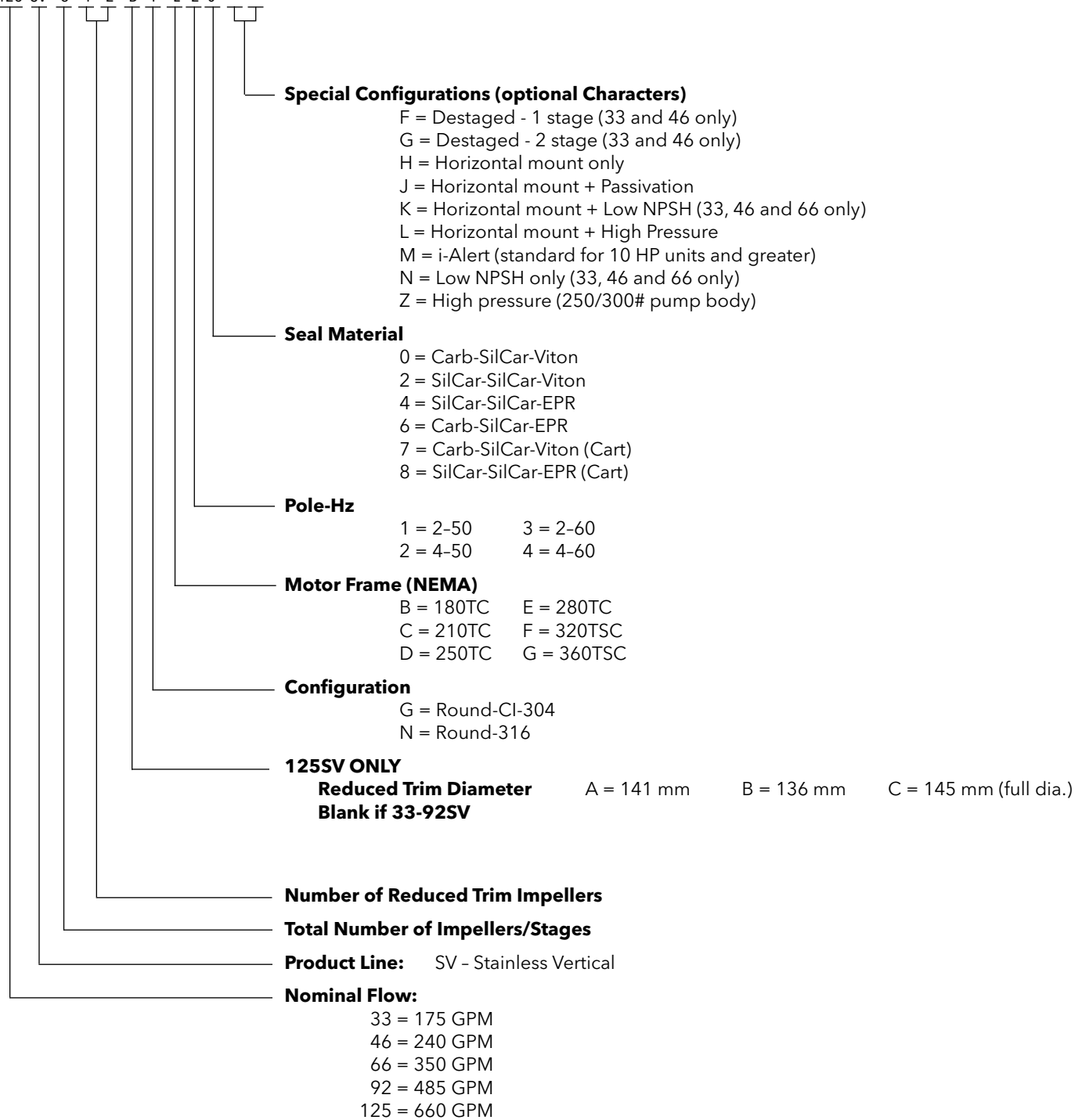

Commercial Water

e-SV Product Line Numbering System for 1 - 22SV Pump & Motor Combination

The various versions of the e-SV line are identified by a product code number on the pump label. This number is also the catalog number for the pump. The meaning of each digit in the product code number is shown below.

Note: Not all combinations are possible.

Example Product Code

2 SV 2 2 F A 2 F 5 1 A H

Special Configurations (1 or 2 Characters)

- | | |
|------------------------------------|--|
| A = Cooling Chamber only | K = Horizontal mount + Low NPSH |
| B = Cooling Chamber + Passivation | L = Horizontal mount + High Pressure |
| C = Cooling Chamber + Low NPSH | M = i-Alert (standard for 10 HP units and greater) |
| F = Destaged - 1 stage | N = Low NPSH only |
| G = Destaged - 2 stage | P = Passivation only |
| H = Horizontal mount only | Z = High Press (250/300# pump body) |
| J = Horizontal mount + Passivation | |

Seal Material

- | | |
|----------------------------------|-----------------------|
| 0 = Carb-SilCar-Viton | 4 = SilCar-SilCar-EPR |
| 1 = Carb-SilCar-AFLAS (HighTemp) | 6 = Carb-SilCar-EPR |
| 2 = SilCar-SilCar-Viton | |

Motor Enclosure

- | | |
|-------------------|---------------|
| 1 = ODP | 7 = Prem-XP |
| 2 = TEFC | 8 = Prem-WD |
| 3 = X-Proof | 9 = Marine |
| 4 = WD - Tropical | A = Chem |
| 5 = Prem-ODP | B = Prem-Chem |
| 6 = Prem-TEFC | |

Voltage

- | | | |
|-----------------|-----------------|---------------------|
| A = 115-230 | H = 190/380 | R = 220 |
| B = 230 | J = 115/208-230 | S = 415 |
| C = 230-460 | K = 208 | T = 220/380 WYE |
| D = 460 | L = 208-230 | U = 380-660 WYE |
| E = 575 | M = 190/380/415 | V = 208-230/460 WYE |
| F = 208-230/460 | N = 380 | |
| G = 200 | P = 110/220 | |

Pole-Hz-Phase

- | | |
|------------|------------|
| 1 = 2-50-1 | 5 = 4-50-1 |
| 2 = 2-50-3 | 6 = 4-50-3 |
| 3 = 2-60-1 | 7 = 4-60-1 |
| 4 = 2-60-3 | 8 = 4-60-3 |

HP Rating

- | | |
|----------|---------|
| A = 0.50 | H = 7.5 |
| B = 0.75 | J = 10 |
| C = 1.00 | K = 15 |
| D = 1.50 | L = 20 |
| E = 2 | M = 25 |
| F = 3 | N = 30 |
| G = 5 | P = 40 |

Configuration OPTION

- | | | |
|---------------------|-----|----------------------|
| C = Clamp-316 | | |
| F = Round-304 (SVB) | R = | (SVC) 12Suct-12Disch |
| G = CI-304 | W = | (SVC) 12Suct-03Disch |
| N = Round-316 (SVD) | X = | (SVC) 12Suct-06Disch |
| P = Victaulic-316 | Y = | (SVC) 12Suct-09Disch |
| T = Oval-304 (SVA) | | |
- Suction discharge location

Total Number of Impeller Stages (may be 1 or 2 characters)

Product Line:

SV - Stainless Vertical

Nominal Flow:

- | | |
|------------|--------------|
| 1 = 5 GPM | 10 = 53 GPM |
| 3 = 16 GPM | 15 = 80 GPM |
| 5 = 26 GPM | 22 = 116 GPM |

e-SV Product Line Numbering System for 33 - 125SV Pump & Motor Combination

The various versions of the e-SV line are identified by a product code number on the pump label. This number is also the catalog number for the pump. The meaning of each digit in the product code number is shown below.

Note: Not all combinations are possible.

Example Product Code

125 SV 8 2 A G K 3 F 2 0

Special Configurations (1 or 2 Characters)

- | | |
|---|--|
| F = Destaged - 1 stage (33 and 46 only) | L = Horizontal mount + High Pressure |
| G = Destaged - 2 stage (33 and 46 only) | M = i-Alert (standard for 10 HP units and greater) |
| H = Horizontal mount only | N = Low NPSH only (33, 46 and 66 only) |
| J = Horizontal mount + Passivation | P = Passivation only |
| K = Horizontal mount + Low NPSH | Z = High Press (250/300# pump body/Casing) |

Seal Material

- | | |
|-------------------------|------------------------------|
| 0 = Carb-SilCar-Viton | 6 = Carb-SilCar-EPR |
| 2 = SilCar-SilCar-Viton | 7 = Carb-SilCar-Viton (Cart) |
| 4 = SilCar-SilCar-EPR | 8 = SilCar-SilCar-EPR (Cart) |

Motor Enclosure

- | | | |
|-------------------|---------------|---------------|
| 1 = ODP | 5 = Prem-ODP | 9 = Marine |
| 2 = TEFC | 6 = Prem-TEFC | A = Chem |
| 3 = X-Proof | 7 = Prem-XP | B = Prem-Chem |
| 4 = WD - Tropical | 8 = Prem-WD | |

Voltage

- | | | |
|-----------------|-----------------|---------------------|
| A = 115-230 | H = 190/380 | R = 220 |
| B = 230 | J = 115/208-230 | S = 415 |
| C = 230-460 | K = 208 | T = 220/380 WYE |
| D = 460 | L = 208-230 | U = 380-660 WYE |
| E = 575 | M = 190/380/415 | V = 208-230/460 WYE |
| F = 208-230/460 | N = 380 | |
| G = 200 | P = 110/220 | |

Pole-Hz-Phase

- | | |
|------------|------------|
| 1 = 2-50-1 | 5 = 4-50-1 |
| 2 = 2-50-3 | 6 = 4-50-3 |
| 3 = 2-60-1 | 7 = 4-60-1 |
| 4 = 2-60-3 | 8 = 4-60-3 |

HP Rating

- | | |
|---------|--------|
| F = 3 | M = 25 |
| G = 5 | N = 30 |
| H = 7.5 | P = 40 |
| J = 10 | R = 50 |
| K = 15 | S = 60 |
| L = 20 | T = 75 |

Configuration

- G = Round-CI-304
N = Round-316

125SV ONLY

- Reduced Trim Diameter** A = 141 mm B = 136 mm C = 145 mm (full dia.)
Blank if 33-92SV

Number of Reduced Trin Impeller

Total Number of Impeller Stages (may be 1 or 2 characters)

Product Line:

SV - Stainless Vertical

Nominal Flow:

- | | |
|--------------|---------------|
| 33 = 175 GPM | 92 = 485 GPM |
| 46 = 240 GPM | 125 = 660 GPM |
| 66 = 350 GPM | |

Base Models: 1-22SV – Major Components

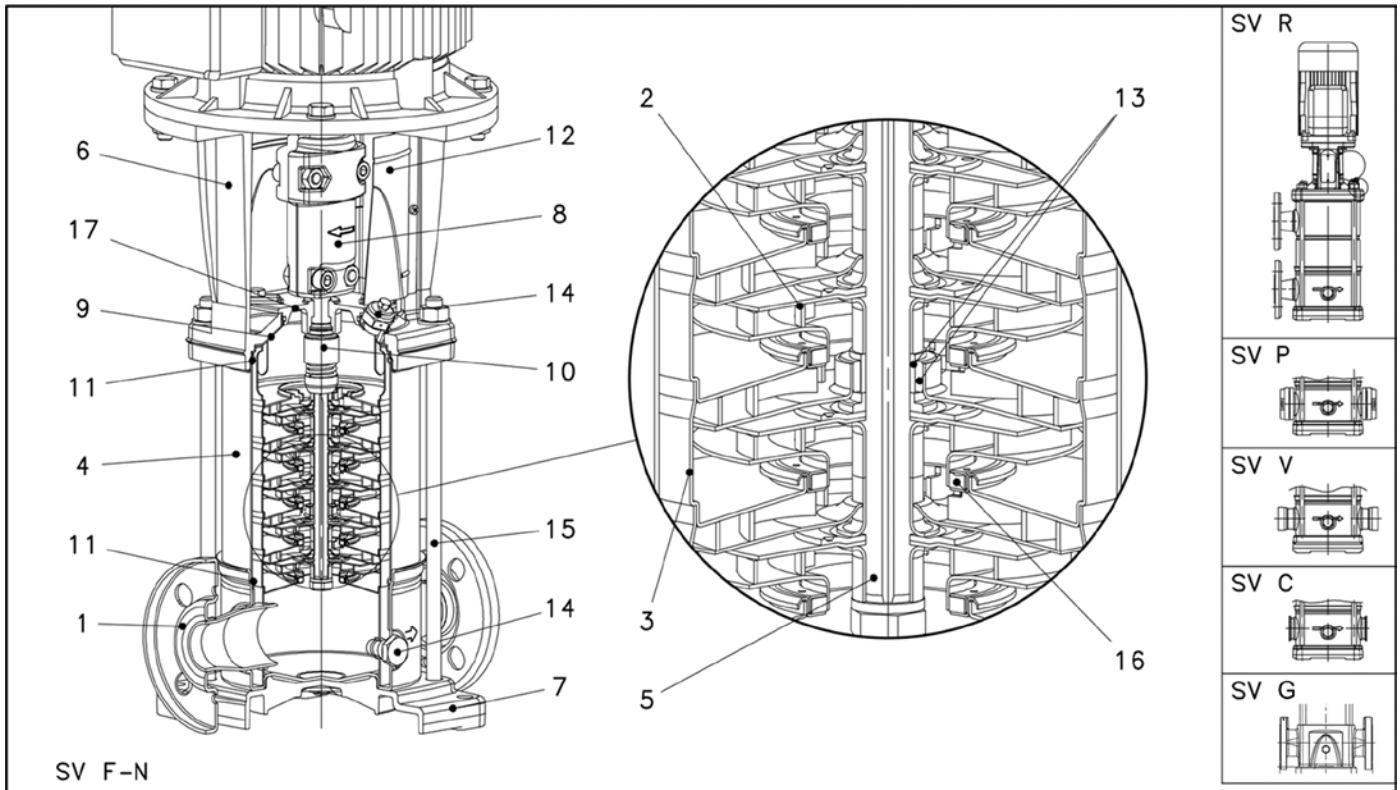

Base Models: 1-22SV – Major Components

F, G, P, R VERSIONS

Ref. No.	Name	Material	Reference Standards	
			USA	Europe
1	Pump Body	Stainless Steel (F, P, R)	AISI 304	EN 10088-1-X5-CrNi18-10 (1.4301)
		Cast Iron (G)	ASTM Class 35/40B	EN 1561 GJL 250 (JL1040)
2	Impeller	Stainless Steel	AISI 304	EN 10088-1-X5-CrNi18-10 (1.4301)
3	Diffuser	Stainless Steel	AISI 304	EN 10088-1-X5-CrNi18-10 (1.4301)
4	Casing	Stainless Steel	AISI 316L	EN 10088-1-X2-CrNiMo17-12-2 (1.4404)
5	Shaft	Stainless Steel	AISI 316	EN 10088-1-X2-CrNiMo17-12-2 (1.4401)
6	Adapter	Cast Iron	ASTM Class 35/40B	EN 1561-GJL-250 (JL1040)
7	Base	Aluminum (F, P, R)	A384.0-F	EN 1706-AC-AISI11Cu2(Fe) (AC46100)
		N/A (G)	N/A	N/A
8	Coupling	Aluminum	A384.0-F	EN 1706-AC-AISI11Cu2(Fe) (AC46100)
9	Seal Plate	Stainless Steel	AISI 316L	EN 10088-1-X2-CrNi17-12-2 (1.4404)
10	Mechanical Seal	Silicon Carbide / Carbon / Viton (opt. EPDM)		
11	Elastomers	Viton (opt. EPDM)		
12	Coupling Guard	Stainless Steel	AISI 304	EN 10088-1-X5-CrNi18-10 (1.4301)
13	Shaft Sleeve and Bushing	Tungsten Carbide		
14	Fill/Drain Plugs	Stainless Steel	AISI 316	EN 10088-1-X2-CrNiMo17-12-2 (1.4401)
15	Tie Rods	Carbon Steel / Zinc Plated	A29 Gr. 1045	EN 10277
16	Wear Ring	PPS		
17	Seal Gland	Stainless Steel	AISI 316	EN 10088-1-X2-CrNiMo17-12-2 (1.4401)

N, P, C VERSIONS

Ref. No.	Name	Material	Reference Standards	
			USA	Europe
1	Pump Body	Stainless Steel	AISI 316L	EN 10088-1-X2-CrNiMo17-12-2 (1.4404)
2	Impeller	Stainless Steel	AISI 316L	EN 10088-1-X2-CrNiMo17-12-2 (1.4404)
3	Diffuser	Stainless Steel	AISI 316L	EN 10088-1-X2-CrNiMo17-12-2 (1.4404)
4	Casing	Stainless Steel	AISI 316L	EN 10088-1-X2-CrNiMo17-12-2 (1.4404)
5	Shaft	Stainless Steel	AISI 316	EN 10088-1-X2-CrNiMo17-12-2 (1.4401)
6	Adapter	Cast Iron	ASTM Class 35/40B	EN 1561-GJL-250 (JL1040)
7	Base	Aluminum	A384.0-F	EN 1706-AC-AISI11Cu2(Fe) (AC46100)
8	Coupling	Aluminum	A384.0-F	EN 1706-AC-AISI11Cu2(Fe) (AC46100)
9	Seal Plate	Stainless Steel	AISI 316L	EN 10088-1-X2-CrNi17-12-2 (1.4404)
10	Mechanical Seal	Silicon Carbide / Carbon / Viton (opt. EPDM)		
11	Elastomers	Viton (opt. EPDM)		
12	Coupling Guard	Stainless Steel	AISI 304	EN 10088-1-X5-CrNi18-10 (1.4301)
13	Shaft Sleeve and Bushing	Tungsten Carbide		
14	Fill/Drain Plugs	Stainless Steel	AISI 316	EN 10088-1-X2-CrNiMo17-12-2 (1.4401)
15	Tie Rods	Carbon Steel / Zinc Plated	A29 Gr. 1045	EN 10277
16	Wear Ring	PPS		
17	Seal Gland	Stainless Steel	AISI 316	EN 10088-1-X2-CrNiMo17-12-2 (1.4401)

Base Model: 33SV, 46SV, 66SV and 92SV – Major Components

SVG-N

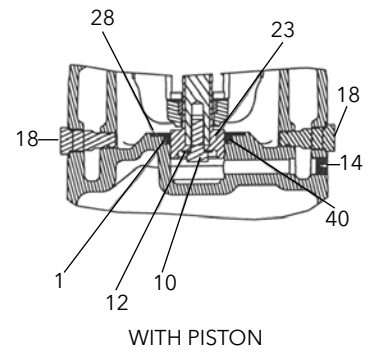
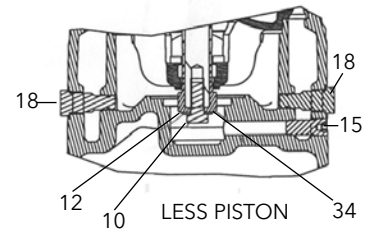
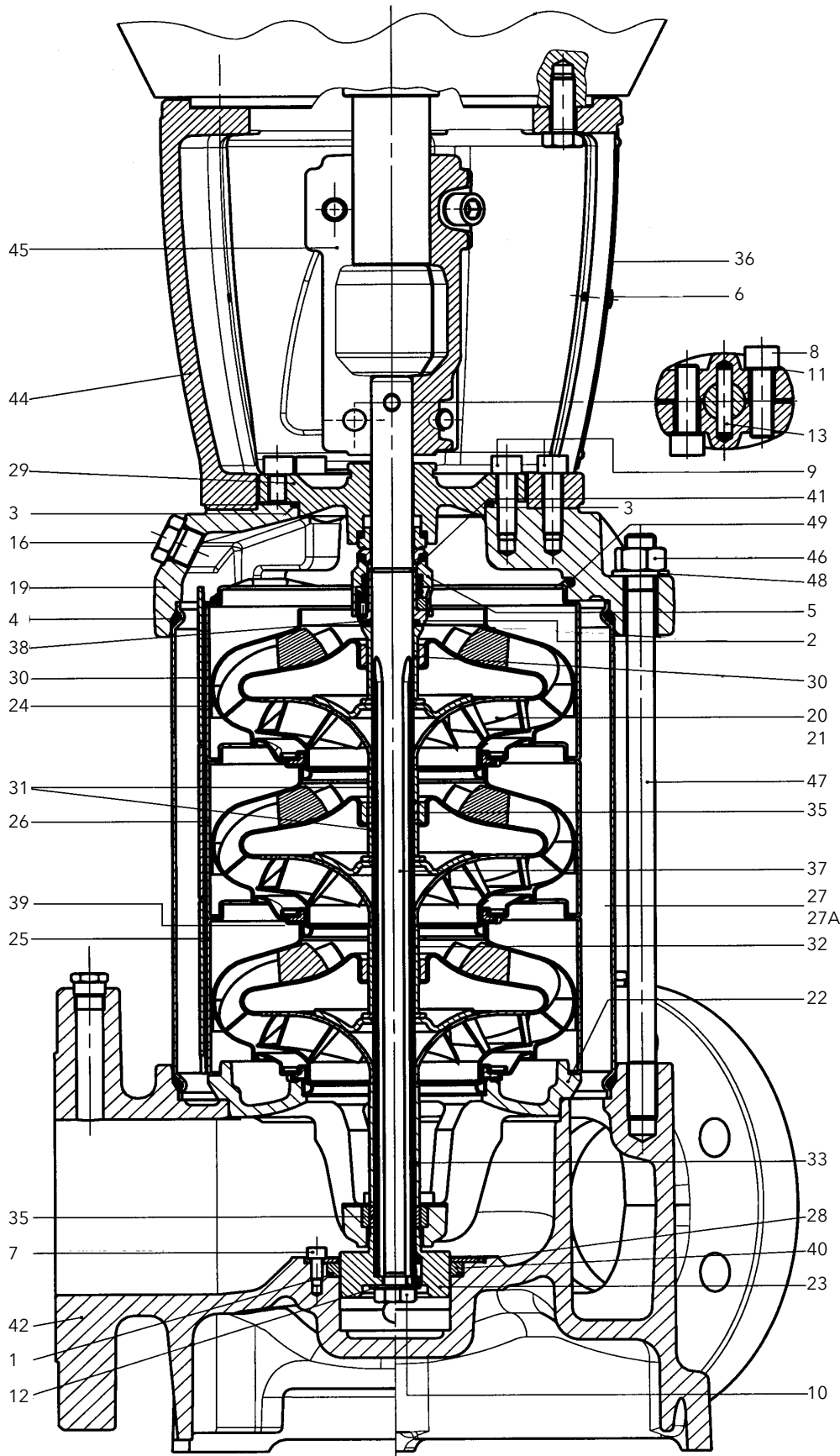

Base Model: 33SV, 46SV, 66SV and 92SV – Major Components

No.	Description	SVG (33 - 92SV)			SVN (33 - 92SV)		
		Material	ASTM	DIN	Material	ASTM	DIN
1	O-Ring, Piston Seal	Viton (std) EPDM (opt)			Viton (std) EPDM (opt)		
2	O-Ring, Mechanical Seal Sleeve	Viton (std) EPDM (opt)			Viton (std) EPDM (opt)		
3	O-Ring, Seal housing	Viton (std) EPDM (opt)			Viton (std) EPDM (opt)		
4	O-Ring, Sleeve	Viton (std) EPDM (opt)			Viton (std) EPDM (opt)		
5	Mechanical Seal	See Seal Materials Chart for Complete DetailSee Sea			Materials Chart for Complete Details		
5A	Cartridge Seal (not shown)						
6	Screw, Guard	Stainless Steel	A193-304	1.4301	Stainless Steel	A193-304	1.4301
7	Screw, Piston Holding Disc	Stainless Steel	A193-316	1.4401	Stainless Steel	A193-316	1.4401
8	Screw, Coupling	Zinc Plated Steel	B363		Zinc Plated Steel	B633	
9	Screw, MA and Seal Housing	Zinc Plated Steel	B633		Zinc Plated Steel	B633	
10	Screw, Impeller	Stainless Steel	A193-316	1.4401	Stainless Steel	A193-316	1.4401
11	Washer, Coupling	Carbon Steel	A108		Carbon Steel	A108	
12	Washer, Impeller	Stainless Steel	A193-316	1.4401	Stainless Steel	A193-316	1.4401
13	Pin, Coupling	Carbon Steel	A108		Carbon Steel	A108	
14	Plug, with Piston	Stainless Steel	A193-316	1.4401	Stainless Steel	A193-316	1.4401
15	Plug, without Piston	Stainless Steel	A193-316	1.4401	Stainless Steel	A193-316	1.4401
16	Plug, Fill	Stainless Steel/O-Ring	A193-316	1.4401	Stainless Steel/O-Ring	A193-316	1.4401
17	Plug, Vent (not shown)	Stainless Steel/O-Ring	A193-316	1.4401	Stainless Steel/O-Ring	A193-316	1.4401
18	Plug, Drain	Stainless Steel/O-Ring	A193-316	1.4401	Stainless Steel/O-Ring	A193-316	1.4401
19	Pump Head	Cast Iron	A48 Class 35	JL1030	Stainless Steel	316 CF8M	1.4408
20	Impeller, Full Diameter	Stainless Steel	A193-316L	1.4404	Stainless Steel	A193-316L	1.4404
21	Impeller, Reduced Diameter	Stainless Steel	A193-316L	1.4404	Stainless Steel	A193-316L	1.4404
22	Lower Bearing Assembly	SS/Cast Iron	A193-316L/A48 Class 35	1.4404/JL1030	Stainless Steel	A193-316L/316 CF8M	1.4404/1.4408
23	Piston	Duplex SS	A182-F51	1.4462	Duplex SS	A182-F51	1.4462
24	Diffuser, Final	Stainless Steel	A193-316L	1.4404	Stainless Steel	A193-316L	1.4404
25	Diffuser with Carbon Bushing	Stainless Steel	A193-316L	1.4404	Stainless Steel	A193-316L	1.4404
26	Diffuser with Tungsten Bushing	Stainless Steel	A193-316L	1.4404	Stainless Steel	A193-316L	1.4404
27	Outer Sleeve, 25 Bar	Stainless Steel	A193-316L	1.4404	Stainless Steel	A193-316L	1.4404
27A	Outer Sleeve, 40 Bar	Stainless Steel	A193-316L	1.4404	Stainless Steel	A193-316L	1.4404
28	Holding Disc, Piston Seal	Stainless Steel	A193-316L	1.4404	Stainless Steel	A193-316L	1.4404
29	Seal Housing	Cast Iron	A48 Class 35	JL1030	Stainless Steel	316 CF8M	1.4408
30	Spacer, Impeller Final	Stainless Steel	A193-316	1.4401	Stainless Steel	A193-316	1.4401
31	Spacer, Shaft Bushing	Stainless Steel	A193-316	1.4401	Stainless Steel	A193-316	1.4401
32	Spacer, Impeller	Stainless Steel	A193-316	1.4401	Stainless Steel	A193-316	1.4401
33	Spacer, Impeller Lower (66-92SV)	Stainless Steel	A193-316	1.4401	Stainless Steel	A193-316	1.4401
34	Bushing, Non-Piston	Stainless Steel	A193-316	1.4401	Stainless Steel	A193-316	1.4401
35	Tungsten Carbide Bushing	Tungsten Carbide			Tungsten Carbide		
36	Coupling Guard	Stainless Steel	A193-304	1.4301	Stainless Steel	304	1.4301
37	Shaft	Duplex SS	A182-F51	1.4462	Duplex SS	A182-F51	1.4462
38	Mechanical Seal Shaft Sleeve	Stainless Steel	A193-316	1.4401	Stainless Steel	A193-316	1.4401
39	Wear Ring, Impeller	PPS Glass Filled			PPS Glass Filled		
40	Piston Seal	Impregnated Carbon			Impregnated Carbon		
41	Stop Ring, Impeller	Stainless Steel	A193-316	1.4401	Stainless Steel	A193-316	1.4401
42	Pump Body	Cast Iron	A48 Class 35	JL1030	Stainless Steel	316 CF8M	1.4408
43	Motor Adapter Plate (not shown)	Cast Iron	A48 Class 25	JL1030	Cast Iron	A48 Class 25	JL1030
44	Motor Adapter	Cast Iron	A48 Class 25	JL1030	Cast Iron	A48 Class 25	JL1030
45	Coupling, Half	Cast Iron	A48 Class 25	JL1030	Cast Iron	A48 Class 25	JL1030
46	Nut, Tie-Rod	Zinc Plated Steel	B633		Zinc Plated Steel	B633	
47	Tie-Rod	Zinc Plated Steel	B633		Zinc Plated Steel	B633	
48	Washer, Tie-Rod	Zinc Plated Steel	B633		Zinc Plated Steel	B633	
49	Spring, Final Diffuser	Stainless Steel	A193-316	1.4401	Stainless Steel	A193-316	1.4401

Base Models: 125SV – Major Components

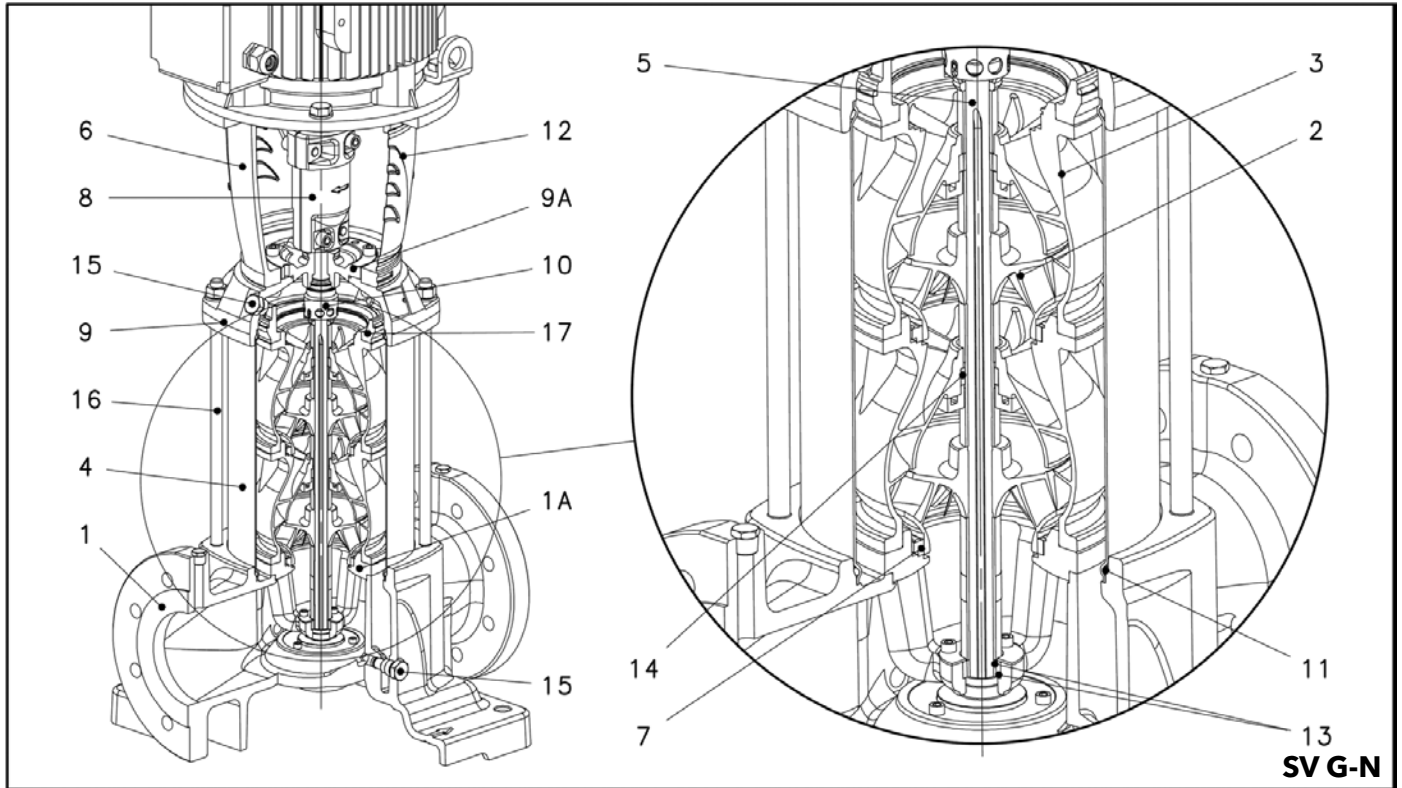

Base Models: 125SV – Major Components

G VERSIONS

Ref. No.	Name	Material	Reference Standards	
			USA	Europe
1	Pump Body	Cast Iron	ASTM Class 35/40B	EN 1561-GJL-250 (JL1040)
2	Impeller	Stainless Steel	AISI 304	EN 10088-1-X5-CrNi18-10 (1.4301)
3	Diffuser	Stainless Steel	AISI 304	EN 10088-1-X5-CrNi18-10 (1.4301)
4	Casing	Stainless Steel	AISI 316L	EN 10088-1-X2-CrNiMo17-12-2 (1.4404)
5	Shaft	Duplex Stainless Steel	UNS S 31803	EN 10088-1-X17-CrNiMoN22-5-3 (1.4507)
6	Adapter (up to 40HP)	Cast Iron	ASTM Class 25	EN 1561-GJL-200 (JL1040)
	Adapter (50HP and higher)		ASTM Class A536	EN 1561-GJL-500-7 (JS1050)
7	Wear Ring	PPS		
8	Coupling (up to 40HP)	Cast Iron	A384.0-F	EN 1706-AC-AISI11Cu2(Fe) (AC46100)
	Coupling (50HP and higher)			
9-9A	Upper Head / Seal Housing	Cast Iron	ASTM Class 35/40B	EN 1561-GJL-250 (JL1040)
10	Mechanical Seal	Silicon Carbide / Carbon / Viton (opt. EPDM)		
11	Elastomers	Viton (opt. EPDM)		
12	Coupling Guard	Stainless Steel	AISI 304	EN 10088-1-X5-CrNi18-10 (1.4301)
13	Shaft Sleeve and Bushing	Tungsten Carbide		
14	Bushing for Diffuser	Carbon		
15	Fill/Drain Plugs	Stainless Steel	AISI 316	EN 10088-1-X2-CrNiMo17-12-2 (1.4401)
16	Tie Rods	Carbon Steel / Zinc Plated	A29 Gr. 1045	EN 10277
17	Adapter Ring	Stainless Steel	AISI 304	EN 10088-1-X5-CrNi18-10 (1.4301)

N VERSIONS

Ref. No.	Name	Material	Reference Standards	
			USA	Europe
1	Pump Body	Stainless Steel	AISI 316	EN 10088-1-X2-CrNiMo17-12-2 (1.4401)
2	Impeller	Stainless Steel	AISI 316	EN 10088-1-X2-CrNiMo17-12-2 (1.4401)
3	Diffuser	Stainless Steel	AISI 316	EN 10088-1-X2-CrNiMo17-12-2 (1.4401)
4	Casing	Stainless Steel	AISI 316L	EN 10088-1-X2-CrNiMo17-12-2 (1.4404)
5	Shaft	Duplex Stainless Steel	UNS S 31803	EN 10088-1-X17-CrNiMoN22-5-3 (1.4507)
6	Adapter (up to 40HP)	Cast Iron	ASTM Class 25	EN 1561-GJL-200 (JL1040)
	Adapter (50HP and higher)		ASTM Class A536	EN 1561-GJL-500-7 (JS1050)
7	Wear Ring	PPS		
8	Coupling (up to 40HP)	Cast Iron	A384.0-F	EN 1706-AC-AISI11Cu2(Fe) (AC46100)
	Coupling (50HP and higher)			
9-9A	Upper Head / Seal Housing	Stainless Steel	AISI 316	EN 10088-1-X2-CrNiMo17-12-2 (1.4401)
10	Mechanical Seal	Silicon Carbide / Carbon / Viton (opt. EPDM)		
11	Elastomers	Viton (opt. EPDM)		
12	Coupling Guard	Stainless Steel	AISI 304	EN 10088-1-X5-CrNi18-10 (1.4301)
13	Shaft Sleeve and Bushing	Tungsten Carbide		
14	Bushing for Diffuser	Carbon		
15	Fill/Drain Plugs	Stainless Steel	AISI 316	EN 10088-1-X2-CrNiMo17-12-2 (1.4401)
16	Tie Rods	Carbon Steel / Zinc Plated	A29 Gr. 1045	EN 10277
17	Adapter Ring	Stainless Steel	AISI 304	EN 10088-1-X5-CrNi18-10 (1.4301)

Commercial Water

e-SV Mechanical Seals

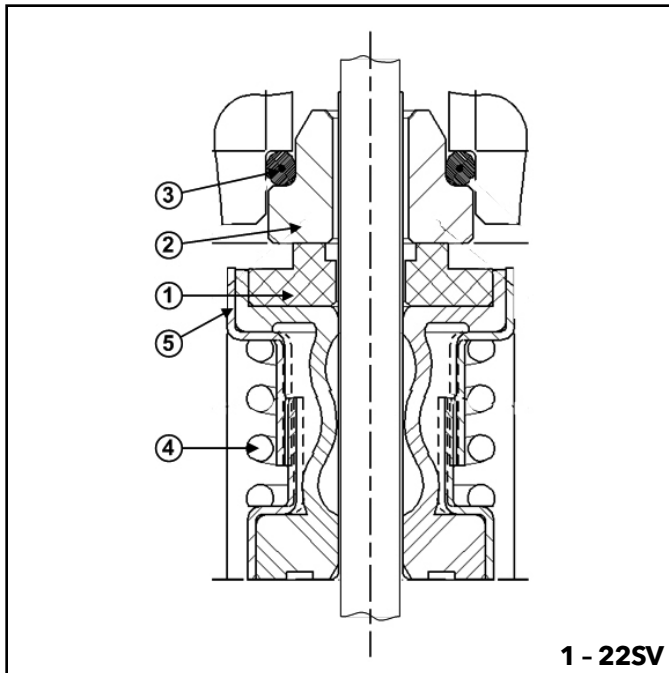

1 - 22SV

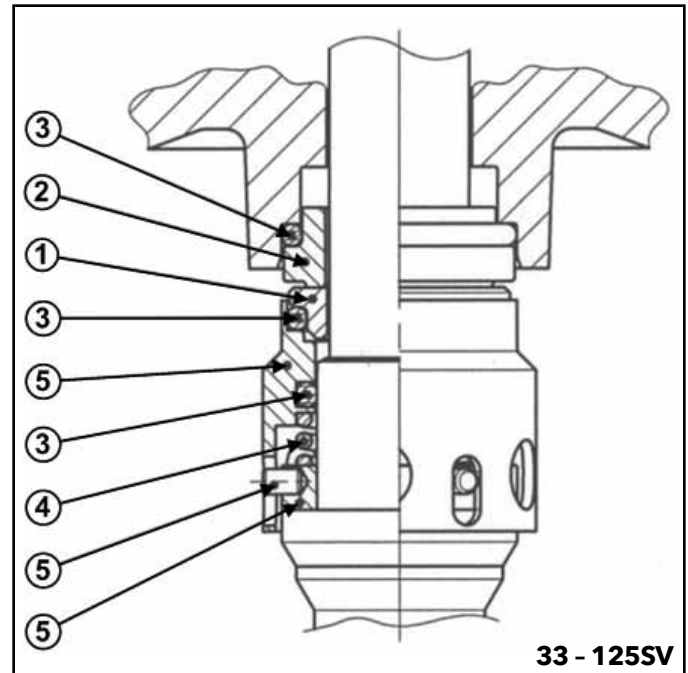

33 - 125SV

Pump	Code	Rotating Face 1	Stationary Face 2	Elastomers 3	Spring 4	Metal Components 5	Elastomer Temp Limits °F (°C)	Seal Temp Limits °F (°C)	Max. Working Pressure	Application
1SV thru 22SV	0	Carbon	Silicon Carbide Graphite Filled	Viton	316SS	316SS	-14 - 392°F (-10 - 200°C)	-22 - 250°F	580 psi (40 bar)	General Service
	2	Silicon Carbide Graphite Filled		EPR			-30 - 300°F (-34 - 150°C)			Severe Duty
	4									Severe Duty Boiler Feed
	6	Carbon		AFLAS			-14 - 392°F (-10 - 200°C)			General Service Boiler Feed
	1	FDA Grade Carbon						Boiler Feed		
33SV thru 125SV	0	Carbon	Silicon Carbide Graphite Filled	Viton	316SS	316SS	-14 - 392°F (-10 - 200°C)	-22 - 250°F (-30 - 120°C)	580 psi (40 bar)	General Service
	2	Silicon Carbide Graphite Filled		EPR			-22 - 250°F (-30 - 120°C)			Severe Duty
	4									Severe Duty Boiler Feed
	6	Carbon		General Service Boiler Feed						

Pump	Rotating Face 1	Stationary Face 2	Elastomers 3	Spring 4	Sleeve 5	Set Screw 6	Locking Collar
33SV	Silicon Carbide	Carbon	Viton	316SS	316SS	300SS	316SS
46SV		Carbon	Viton				
66SV		Silicon Carbide	EPR				
92SV		Silicon Carbide	EPR				

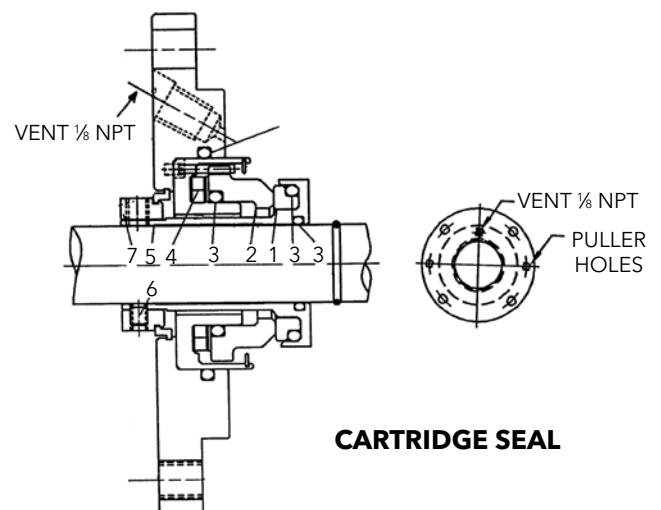

CARTRIDGE SEAL

Maximum Allowable Working Pressure Charts

1SV-22SV

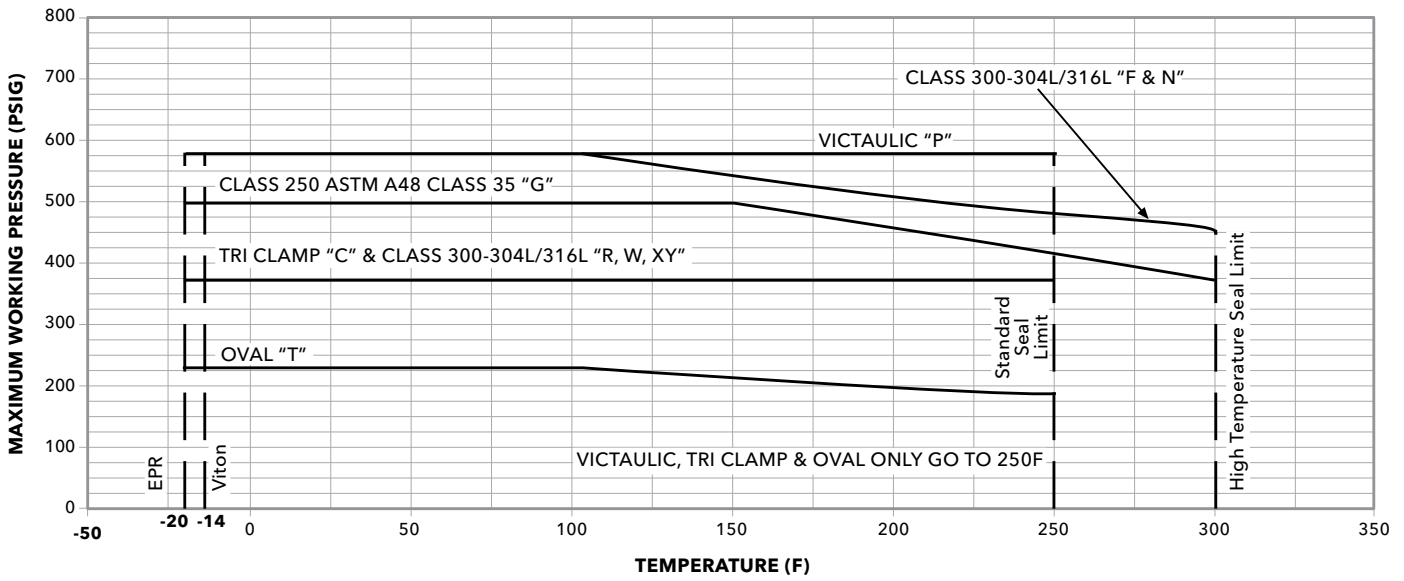

33SV-125SV

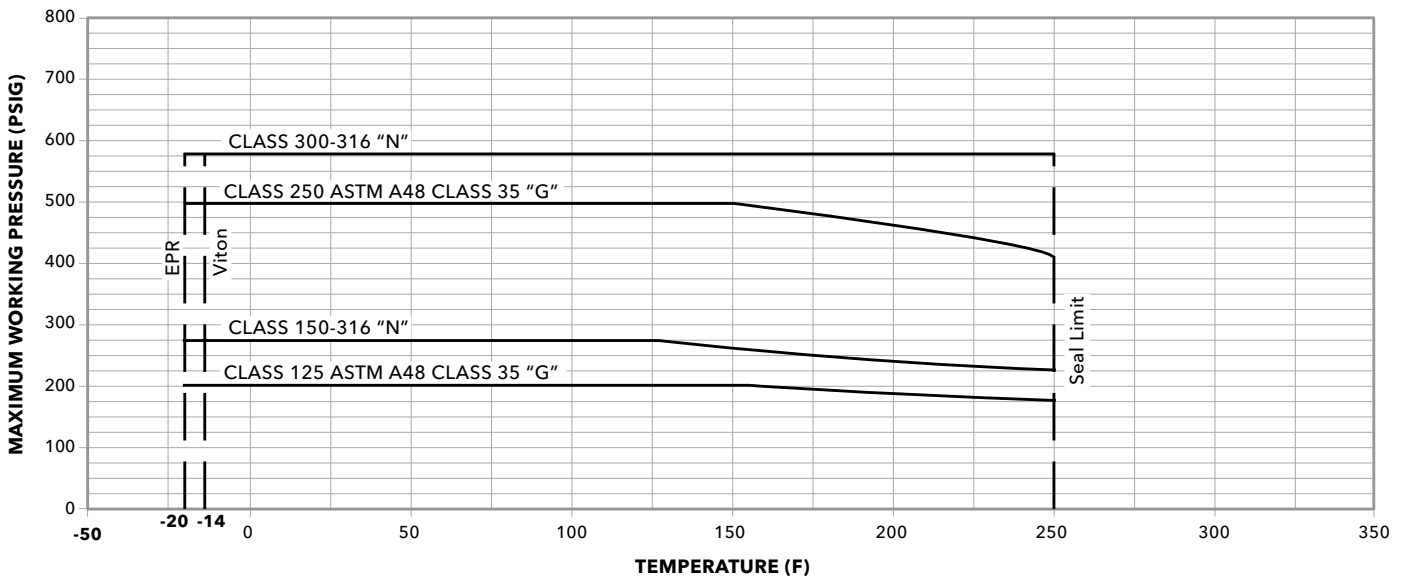

Maximum Inlet Pressure

The following table shows the maximum permissible inlet pressure. However, the actual inlet pressure + pressure against a closed valve must always be lower than the maximum permissible operating pressure.

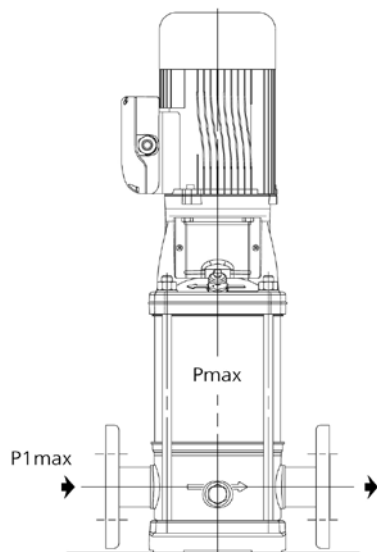

$$p_{1\max} \leq PN - p_{\max}$$

Having the following meaning of the symbols:

p_{\max} = Maximum pressure delivered by the pump

$p_{1\max}$ = Maximum inlet pressure

PN = Maximum operating pressure

Motor Data - Starts per Hour / Minimum Run Time

HP	Maximum Starts per Hour*	Minimum run time between starts (seconds)
0.5	24	120
0.75	24	120
1	15	75
1.5	13	76
2	12	77
3	9	30
5	8	83
7.5	7	88
10	6	92
15	5	100
20	5	110
25	5	115
30	4	120
40	4	130
50	3	145
60	3	170
75	3	180

NOTE(S)

- 1) Recommended motor starts per hour and minimum run time calculated based on NEMA standards MG1-12.44 in accordance to manufacturers allowable tolerance for heat rise and insulation breakdown.
- 2) Applied voltage and frequency in accordance with NEMA MG1-12.44
- 3) Starts based on NEMA three phase design A and design B AC induction motors.
- 4) External load WK2 is equal to or less than the values listed in NEMA MG1-12.54
- 5) Applicable to all NEMA (JM, JP, T and TC frame) motors used for Goulds Pumps products.
- 6) Applicable to three phase motors only.

Motor Data

2900 RPM, 50Hz

HP	Phase	Enclosure	Voltage	SF	NEMA Frame	Speed / Pole	
						2900 / 2	1450 / 4
0.50	1	ODP	110/200	1.25	56C	V04A14K1BB3S	V04A14K1BB3S
		TEFC				V04A14K2BB3S	V04A14K2BB3S
	3	ODP	190/380-415			0V05741Z	V04A34U1BB3S
		TEFC				0V05742Z	V04A34U2BB3S
		TEPE				V04B32U5BB2S	V04A34U5BB3S
		ODPE				V04A34U4BB3S	V04A34U4BB3S
0.75	1	ODP	110/200			V05B12K1BB2S	V05B14K1BB2S
		TEFC				V05B12K2BB2S	V05B14K2BB2S
	3	ODP	190/380-415			0V06741Z	V05A34U1BB3S
		TEFC				0V06742Z	V05A34U2BB3S
		TEPE				V05B32U5BB2S	V05B34U5BB2S
		ODPE				V05B32U4BB2S	V05B34U4BB2S
1.00	1	ODP	110/200	V06B12K1BB2S	V06B14K1BB2S		
		TEFC		V06B12K2BB2S	V06B14K2BB2S		
	3	ODP	190/380-415	0V07741Z	V06A34U1BB2S		
		TEFC		0V07742Z	V06A34U2BB2S		
		ODPE		V06B32U4BB2S	V06B34U4BB2S		
		TEPE		V06B32U5BB2S	V06B34U5BB2S		
1.50	1	ODP	110/200	V07B12K1BB2S	V07B14K1BB2S		
		TEFC		0V08722Z	V07B14K2BB2S		
	3	ODP	190/380-415	0V08741Z	V07A34U1BB2S		
		TEFC		0V08742Z	V07A34U2BB2S		
		ODPE		V07B32U4BB2S	V07B34U4BB2S		
		TEPE		V07B32U5BB2S	V07B34U5BB2S		
2	1	ODP	110/200	V08B12K1BB2S	V08B14K1BD2S		
		TEFC		V08B12K2BB2S	V08B14K2BD2S		
	3	ODP	190/380-415	0V09741Z	V08A34U1BB2S		
		TEFC		0V09742Z	V08A34U2BB2S		
		ODPE		V08B32U4BB2S	V08B34U4BD2S		
		TEPE		V08B32U5BD2S	V08B34U5BD2S		
3	1	ODP	110/200	182TC	V09B12K1BD2S		
		TEFC		V09B12K2BD2S	V09B14K2BD2S		
	3	ODP	190/380-415	184TC	0V10741ZA		
		TEFC		0V10742ZA	V09A34U1BD2S		
		ODPE		V09B32U4BD2S	V09B34U4BD2S		
		TEPE		V09B32U5BD2S	V09B34U5BD2S		
5	1	ODP	110/200	182TC	V10B12N1BD2S		
		TEFC		V10B12N1BD2S	V10B14N1BD2S		
	3	ODP	190/380-415	213TC	V10B12N2BD1S		
		TEFC		0V11741ZA	V10B14N2BE2S		
		ODPE		0V11742ZA	V10B34U1BE2S		
		TEPE		V10B32U4BD2S	V10B34U2BE2S		
7.5	1	ODP	110/200	184TC	V10B32U5BD2S		
		TEFC		V10B32U5BD2S	V10B34U5BD2S		
	3	ODP	190/380-415	215TC	V11B12N1BE2S		
		TEFC		184TC	V11B12N2BD2S		
		ODPE		0V12741Z	V11A14K1BE2S		
		TEPE		0V12742Z	V11A14K2BD2S		
7.5	3	ODP	190/380-415	213TC	0V12741Z		
		TEFC		0V12742Z	V11A34U1BE2S		
7.5	3	ODPE	190/380-415	213TC	0V12742Z		
		TEPE		V11B32U4BE2S	V11B34U4BE2S		
7.5	3	ODPE	190/380-415	215TC	V11B32U5BE2S		
		TEPE		V11B32U5BE2S	V11B34U5BE2S		

Motor Data

2900 RPM, 50Hz

HP	Phase	Enclosure	Voltage	SF	NEMA Frame	Speed / Pole	
						2900 / 2	1450 / 4
10	3	ODP	190/380-415	1.15	254TC	0V13741Z	V12B34U1BK2S
		TEFC			254TC	0V13742Z	V12B34U2BK2S
		ODPE			215TC	V12B32U4BE2S	V12B34U4BE2S
		TEPE			215TC	V12B32U5BK2S	V12B34U5BE2S
15	3	ODP			256TC	0V14741Z	V13B34U1BK2S
		TEFC			256TC	0V14742Z	V13B34U2BK2S
		ODPE			215TC	V13B32U4BE2S	V13B34U4BK2S
		TEPE			254TC	V13B32U5BK2S	V13B34U5BK2S
20	3	ODP			284TC	0V15741Z	V14B34U1BL2S
		TEFC			284TC	0V15742Z	V14B34U2BL2S
		ODPE			256TC	V14B32U4BK2S	V14B34U4BK2S
		TEPE			256TC	V14B32U5BK2S	V14B34U5BK2S
25	3	ODP			286TC	0V16741Z	V15B34U1BL2S
		TEFC			286TC	0V16742Z	V15B34U2BL2S
		ODPE			256TC	V15B32U4BK2S	V15B34U4BL2S
		TEPE			284TC	V15B32U5BL2S	V15B34U5BL2S
30	3	ODP			286TC	0V17741Z	V16B34U1BL2S
		TEFC			286TC	0V17742Z	V16B34U2BL2S
		ODPE			286TC	V16B32U4BL2S	V16B34U4BL2S
		TEPE			286TC	V16B32U5BL2S	V16B34U5BL2S
40	3	ODP			324TSC	0V18741SZ	V17B34U1BM2S
		TEFC			324TSC	0V18742SZ	V17B34U2BM2S
		ODPE			286TC	V17B32U4BL2S	V17B34U4BM2S
		TEPE			324TSC	X17B32U5BM2S	V17B34U5BM2S
50	3	ODP	324TSC	X18A34U1BM2S	V18B34U1BM2S		
		TEFC	324TSC	0V19742SZ	V18B34U2BM2S		
		ODPE	324TSC	X18B32U4BM2S	V18B34U4BM2S		
		TEPE	326TSC	X18B32U5BM2S	V18B34U5BM2S		
60	3	ODP	324TSC	X19A34U1BM2S	V19B34U1BP2S		
		TEFC	324TSC	0V20742SZ	V19B34U2BP2S		
		ODPE	326TSC	X18B32U4BM2S	V19B34U4BP2S		
		TEPE	364TSC	X18B32U5BP2S	V19B34U5BP2S		

NOTE: Motors are suitable for Hydrovar® Variable Speed Drive.

Above data is for Baldor® TC and TSC frame motors. Specifications subject to change without notice.

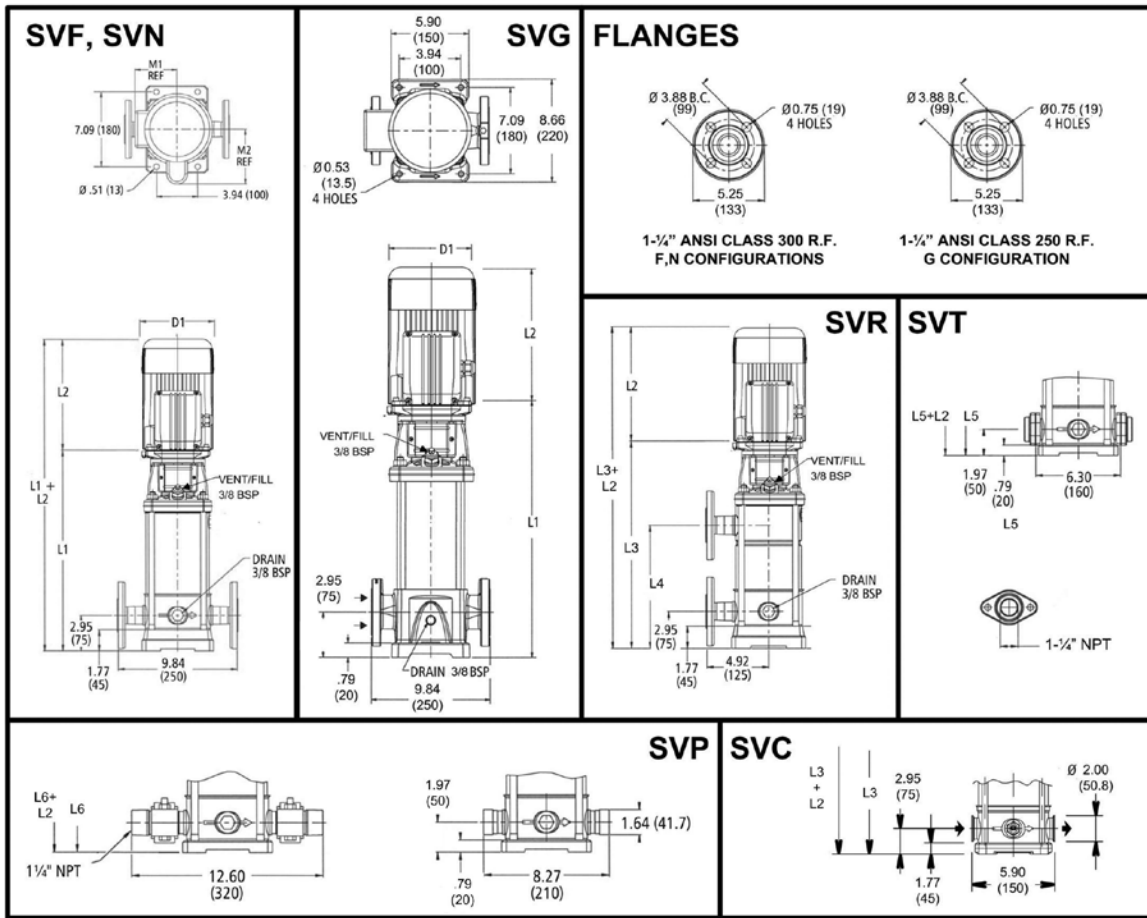

All dimensions are in inches (mm).

Pump Type Stages	Motor				Dimensions (in)												Weight (lbs.)											
	NEMA Frame				L2								D1 (max.)				Motor				Pump/Motor							
	HP	ODP 1Ø	TEFC 1Ø	ODP 3Ø	TEFC 3Ø	L1	ODP 1Ø	TEFC 1Ø	ODP 3Ø	TEFC 3Ø	L3	L4	L5	L6	M (Ref.)	ODP 1Ø	TEFC 1Ø	ODP 3Ø	TEFC 3Ø	D2	Pump Only	ODP 1Ø	TEFC 1Ø	ODP 3Ø	TEFC 3Ø	ODP 1Ø	TEFC 1Ø	ODP 3Ø
1SV-02	0.5	56C	13.27	10.79	9.91	9.16	9.29	-	-	12.29	12.29	5.19	6.19	6.19	6.19	6.19	4.13	25	27	29	21	21	52	54	46	46		
1SV-03			13.27	10.79	9.91	9.16	9.29	-	-	12.29	12.29	5.19	6.19	6.19	6.19	6.19	4.13	26	27	29	21	21	53	55	47	47		
1SV-04			14.06	10.79	9.91	9.16	9.29	-	-	13.07	13.07	5.19	6.19	6.19	6.19	6.19	4.13	27	27	29	21	21	54	56	48	48		
1SV-05			14.85	10.79	9.91	9.16	9.29	-	-	13.86	13.86	5.19	6.19	6.19	6.19	6.19	4.13	28	27	29	21	21	55	57	49	49		
1SV-06			15.63	10.79	9.91	9.16	9.29	-	-	14.65	14.65	5.19	6.19	6.19	6.19	6.19	4.13	28	27	29	21	21	55	57	49	49		
1SV-07			16.42	10.79	9.91	9.16	9.29	-	-	15.44	15.44	5.19	6.19	6.19	6.19	6.19	4.13	29	27	29	21	21	56	58	50	50		
1SV-08			17.21	10.79	9.91	9.16	9.29	17.21	8.94	16.22	16.22	5.19	6.19	6.19	6.19	6.19	4.13	30	27	29	21	21	57	59	51	51		
1SV-09			18.00	10.66	11.19	9.16	9.29	18.00	9.72	17.01	17.01	5.74	6.19	7.19	6.19	6.19	4.13	31	32	40	23	23	63	71	54	54		
1SV-10			18.78	10.66	11.19	9.16	9.29	18.78	10.51	17.80	17.80	5.74	6.19	7.19	6.19	6.19	4.13	32	32	40	23	23	64	72	55	55		
1SV-11			19.57	10.66	11.19	9.16	9.29	19.57	11.30	18.59	18.59	5.74	6.19	7.19	6.19	6.19	4.13	33	32	40	23	23	65	73	56	56		
1SV-12			20.36	10.66	11.19	9.16	9.29	20.36	12.09	19.37	19.37	5.74	6.19	7.19	6.19	6.19	4.13	34	32	40	23	23	66	74	57	57		
1SV-13			21.14	10.66	11.19	9.16	9.29	21.14	12.87	20.16	20.16	5.74	6.19	7.19	6.19	6.19	4.13	35	32	40	23	23	67	75	58	58		
1SV-14			21.93	10.67	11.19	10.66	9.91	21.93	13.66	20.95	20.95	5.74	6.19	7.19	6.19	6.19	4.72	36	32	40	30	28	68	76	66	64		
1SV-15			22.72	10.67	11.19	10.66	9.91	22.72	14.45	21.74	21.74	5.74	6.19	7.19	6.19	6.19	4.72	37	32	40	30	28	69	77	67	65		
1SV-16			23.51	10.67	11.19	10.66	9.91	23.51	15.24	22.52	22.52	5.74	6.19	7.19	6.19	6.19	4.72	38	32	40	30	28	70	78	68	66		
1SV-17			24.29	10.67	11.19	10.66	9.91	24.29	16.02	23.31	23.31	5.74	6.19	7.19	6.19	6.19	4.72	38	32	40	30	28	70	78	68	66		
1SV-18			25.08	11.18	12.06	11.16	10.79	25.08	16.81	24.10	24.10	5.74	7.19	7.19	6.19	6.19	4.72	39	43	51	32	33	82	90	71	72		
1SV-19			25.87	11.18	12.06	11.16	10.79	25.87	17.60	24.89	24.89	5.74	7.19	7.19	6.19	6.19	4.72	40	43	51	32	33	83	91	72	73		
1SV-20			26.66	11.18	12.06	11.16	10.79	26.66	18.39	25.67	25.67	5.74	7.19	7.19	6.19	6.19	4.72	41	43	51	32	33	84	92	73	74		
1SV-21			27.44	11.18	12.06	11.16	10.79	27.44	19.17	26.46	26.46	5.74	7.19	7.19	6.19	6.19	4.72	42	43	51	32	33	85	93	74	75		
1SV-22			28.23	11.18	12.06	11.16	10.79	28.23	19.96	27.25	27.25	5.74	7.19	7.19	6.19	6.19	4.72	43	43	51	32	33	86	94	75	76		
1SV-23			29.02	11.18	12.06	11.16	10.79	29.02	20.75	28.03	28.03	5.74	7.19	7.19	6.19	6.19	4.72	45	43	51	32	33	88	96	77	78		
1SV-24			29.81	11.18	12.06	11.16	10.79	29.81	21.54	28.82	28.82	5.74	7.19	7.19	6.19	6.19	4.72	46	43	51	32	33	89	97	78	79		
1SV-25			30.59	11.18	12.06	11.16	10.79	30.59	22.32	29.61	29.61	5.74	7.19	7.19	6.19	6.19	4.72	47	43	51	32	33	90	98	79	80		
1SV-26			31.38	11.18	12.06	11.16	10.79	31.38	23.11	30.40	30.40	5.74	7.19	7.19	6.19	6.19	4.72	47	43	51	32	33	90	98	79	80		
1SV-27			32.17	11.57	13.44	11.18	11.16	32.17	23.90	-	31.18	5.75	6.50	7.19	7.16	7.19	5.51	48	49	64	41	44	97	112	89	92		
1SV-28			32.96	11.57	13.44	11.18	11.16	32.96	24.68	-	31.97	5.75	6.50	7.19	7.16	7.19	5.51	49	49	64	41	44	98	113	90	93		
1SV-29			34.14	11.57	13.44	11.18	11.16	34.14	25.47	-	33.15	5.75	6.50	7.19	7.16	7.19	5.51	50	49	64	41	44	99	114	91	94		
1SV-30			34.53	11.57	13.44	11.18	11.16	34.53	26.26	-	33.55	5.75	6.50	7.19	7.16	7.19	5.51	51	49	64	41	44	100	115	92	95		

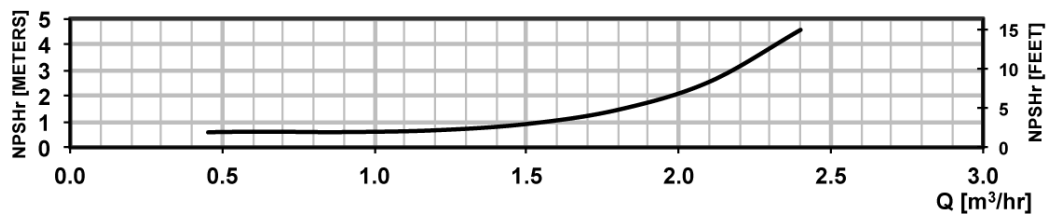
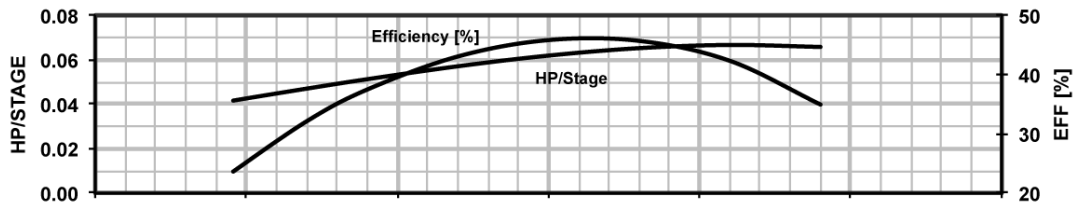
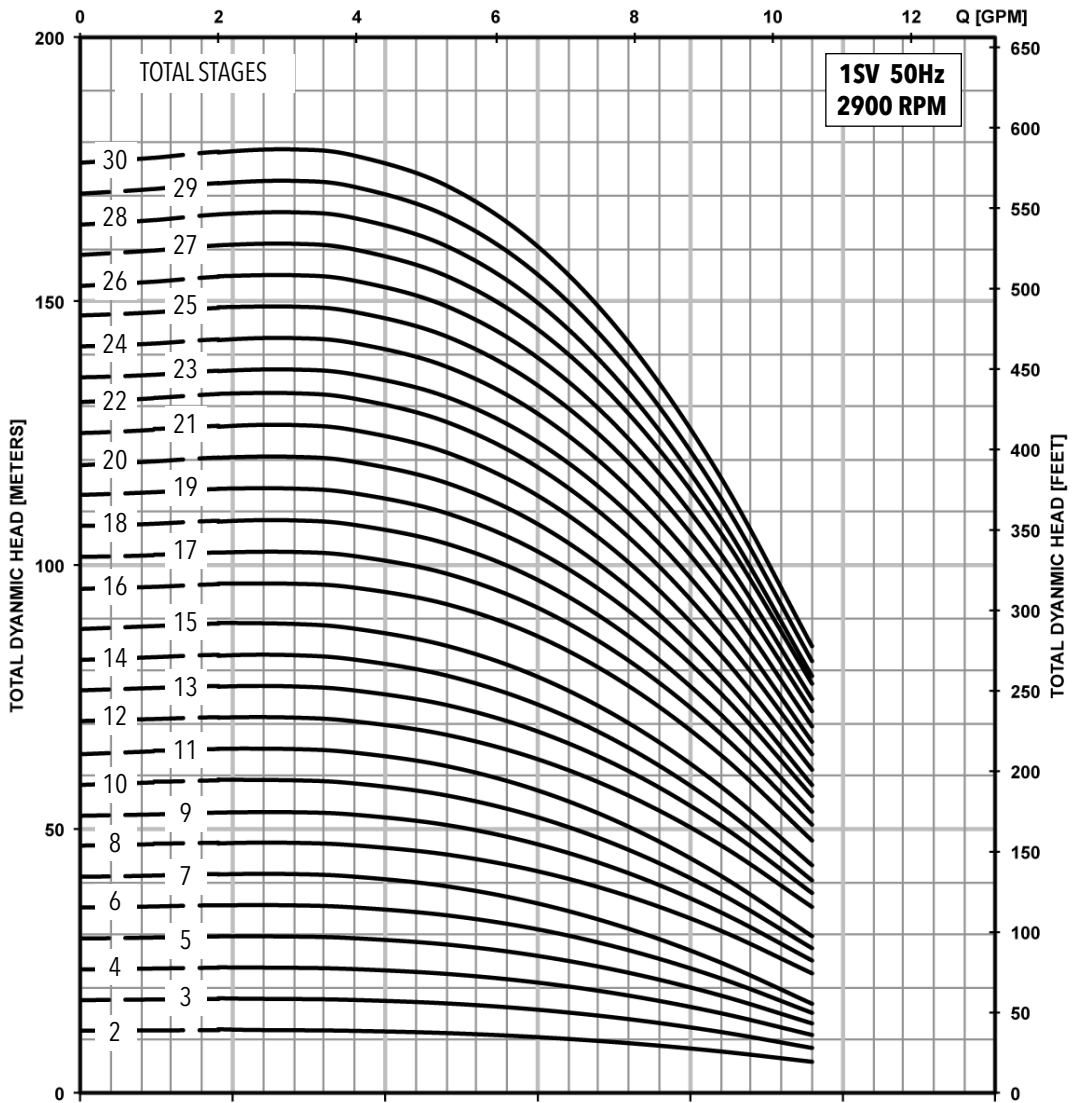

MINIMUM FLOW RATE: 0.5 m³/hr [2 GPM]

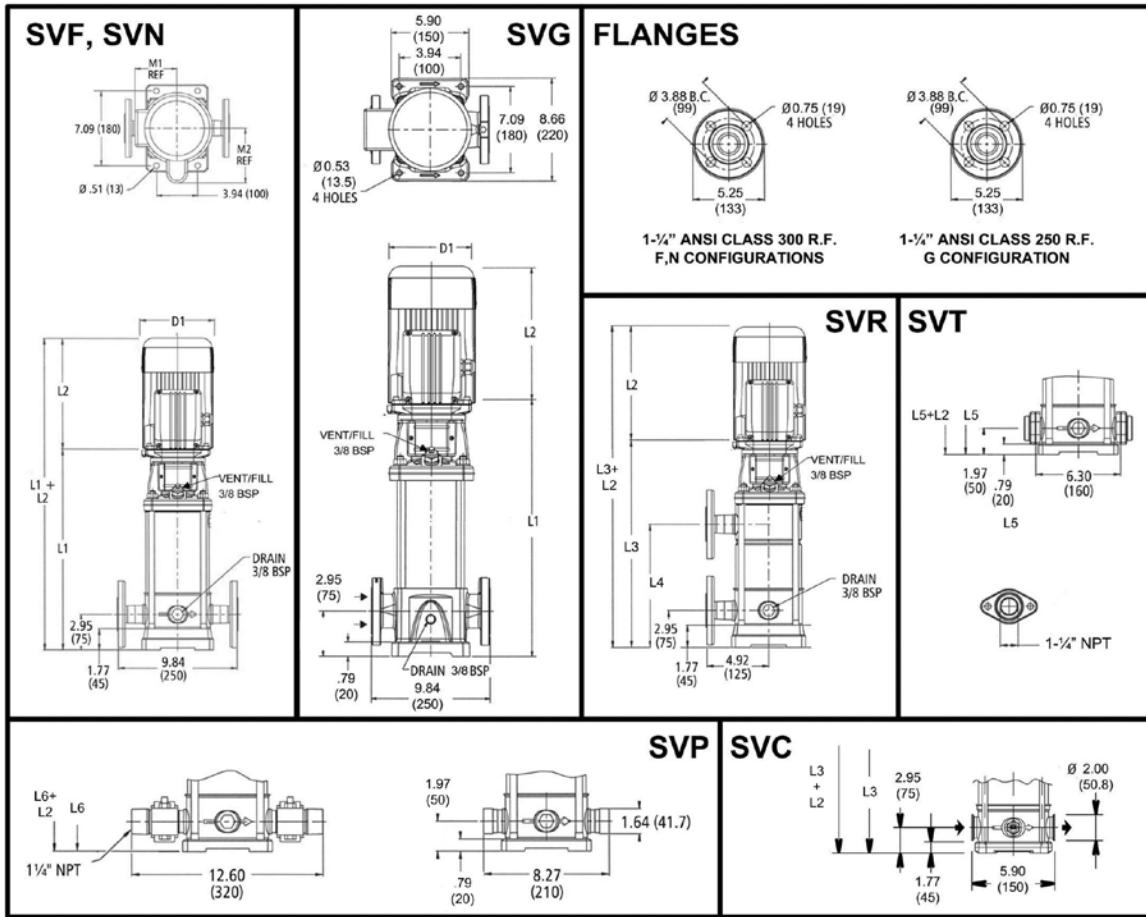

All dimensions are in inches (mm).

Pump Type Stages	Motor				Dimensions (in)											Weight (lbs.)													
	HP	NEMA Frame				L1	L2				L3	L4	L5	L6	M (Ref.)	D1 (max.)				D2	Pump	Motor				Pump/Motor			
		ODP 10	TEFC 10	ODP 30	TEFC 30		ODP 10	TEFC 10	ODP 30	TEFC 30						ODP 10	TEFC 10	ODP 30	TEFC 30			ODP 10	TEFC 10	ODP 30	TEFC 30	ODP 10	TEFC 10	ODP 30	TEFC 30
3SV-02	0.5	56C			13.27	10.79	9.91	9.16	9.29	-	-	12.29	12.29	5.19	6.19	6.19	6.19	6.19	4.13	24	27	29	21	21	51	53	45	45	
3SV-03					13.27	10.79	9.91	9.16	9.29	-	-	12.29	12.29	5.19	6.19	6.19	6.19	6.19	6.19	4.13	25	27	29	21	21	52	54	46	46
3SV-04					14.06	10.79	9.91	9.16	9.29	-	-	13.07	13.07	5.19	6.19	6.19	6.19	6.19	6.19	4.13	26	27	29	21	21	53	55	47	47
3SV-05					14.85	10.79	9.91	9.16	9.29	-	-	13.86	13.86	5.19	6.19	6.19	6.19	6.19	6.19	4.13	27	27	29	21	21	54	56	48	48
3SV-06					15.63	10.66	11.19	9.16	9.29	-	-	14.65	14.65	5.74	6.19	7.19	6.19	6.19	6.19	4.13	28	32	40	23	23	60	68	51	51
3SV-07					16.42	10.66	11.19	9.16	9.29	-	-	15.44	15.44	5.74	6.19	7.19	6.19	6.19	6.19	4.13	30	32	40	23	23	62	70	53	53
3SV-08					17.21	10.66	11.19	9.16	9.29	17.21	8.94	16.22	16.22	5.74	6.19	7.19	6.19	6.19	6.19	4.13	31	32	40	23	23	63	71	54	54
3SV-09					18.00	10.67	11.19	10.66	9.91	18.00	9.72	17.01	17.01	5.74	6.19	7.19	6.19	6.19	6.19	4.72	32	32	40	30	28	64	72	62	60
3SV-10					18.78	10.67	11.19	10.66	9.91	18.78	10.51	17.80	17.80	5.74	6.19	7.19	6.19	6.19	6.19	4.72	33	32	40	30	28	65	73	63	61
3SV-11					19.57	11.18	12.06	11.16	10.79	19.57	11.30	18.59	18.59	5.74	7.19	7.19	6.19	6.19	6.19	4.72	34	43	51	32	33	77	85	66	67
3SV-12					20.36	11.18	12.06	11.16	10.79	20.36	12.09	19.37	19.37	5.74	7.19	7.19	6.19	6.19	6.19	4.72	35	43	51	32	33	78	86	67	68
3SV-13					21.14	11.18	12.06	11.16	10.79	21.14	12.87	20.16	20.16	5.74	7.19	7.19	6.19	6.19	6.19	4.72	36	43	51	32	33	79	87	68	69
3SV-14					21.93	11.18	12.06	11.16	10.79	21.93	13.66	20.95	20.95	5.74	7.19	7.19	6.19	6.19	6.19	4.72	37	43	51	32	33	80	88	69	70
3SV-15					22.72	11.18	12.06	11.16	10.79	22.72	14.45	21.74	21.74	5.74	7.19	7.19	6.19	6.19	6.19	4.72	38	43	51	32	33	81	89	70	71
3SV-16					23.51	11.18	12.06	11.16	10.79	23.51	15.24	22.52	22.52	5.74	7.19	7.19	6.19	6.19	6.19	4.72	39	43	51	32	33	82	90	71	72
3SV-17					24.29	11.57	13.44	11.18	11.16	24.29	16.02	23.31	23.31	5.75	6.50	7.19	7.16	7.19	5.51	40	49	64	41	44	89	104	81	84	
3SV-18	25.08	11.57	13.44	11.18	11.16	25.08	16.81	24.10	24.10	5.75	6.50	7.19	7.16	7.19	5.51	41	49	64	41	44	90	105	82	85					
3SV-19	25.87	11.57	13.44	11.18	11.16	25.87	17.60	24.89	24.89	5.75	6.50	7.19	7.16	7.19	5.51	41	49	64	41	44	90	105	82	85					
3SV-20	26.66	11.57	13.44	11.18	11.16	26.66	18.39	25.67	25.67	5.75	6.50	7.19	7.16	7.19	5.51	42	49	64	41	44	91	106	83	86					
3SV-21	27.44	11.57	13.44	11.18	11.16	27.44	19.17	26.46	26.46	5.75	6.50	7.19	7.16	7.19	5.51	43	49	64	41	44	92	107	84	87					
3SV-22	28.93	13.93	15.43	12.55	13.93	28.93	19.96	-	27.95	6.87	8.88	8.86	9.02	8.86	5.51	46	81	92	62	69	127	138	108	115					
3SV-23	29.72	13.93	15.43	12.55	13.93	29.72	20.75	-	28.73	6.87	8.88	8.86	9.02	8.86	5.51	47	81	92	62	69	128	139	109	116					
3SV-24	30.51	13.93	15.43	12.55	13.93	30.51	21.54	-	29.52	6.87	8.88	8.86	9.02	8.86	5.51	48	81	92	62	69	129	140	110	117					
3SV-25	31.29	13.93	15.43	12.55	13.93	31.29	22.32	-	30.31	6.87	8.88	8.86	9.02	8.86	5.51	49	81	92	62	69	130	141	111	118					
3SV-26	32.08	13.93	15.43	12.55	13.93	32.08	23.11	-	31.10	6.87	8.88	8.86	9.02	8.86	5.51	50	81	92	62	69	131	142	112	119					
3SV-27	32.47	13.93	15.43	12.55	13.93	32.47	23.90	-	31.49	6.87	8.88	8.86	9.02	8.86	5.51	52	81	92	62	69	133	144	114	121					
3SV-28	33.26	13.93	15.43	12.55	13.93	33.26	24.68	-	32.28	6.87	8.88	8.86	9.02	8.86	5.51	53	81	92	62	69	134	145	115	122					
3SV-29	34.44	13.93	15.43	12.55	13.93	34.44	25.47	-	33.46	6.87	8.88	8.86	9.02	8.86	5.51	54	81	92	62	69	135	146	116	123					
3SV-30	35.23	13.93	15.43	12.55	13.93	35.23	26.26	-	34.25	6.87	8.88	8.86	9.02	8.86	5.51	55	81	92	62	69	136	147	117	124					

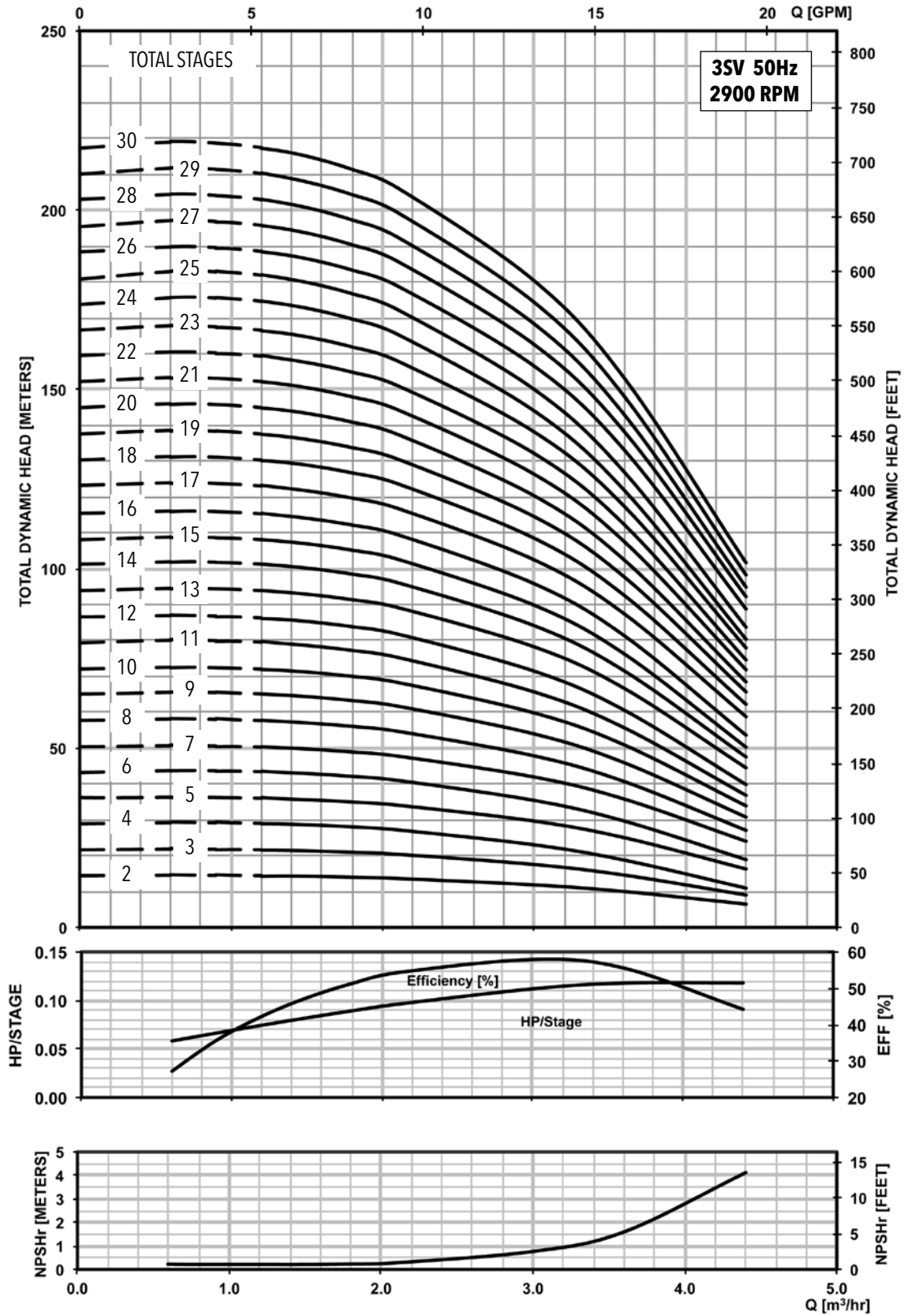

MINIMUM FLOW RATE: 0.7 m³/hr [3 GPM]

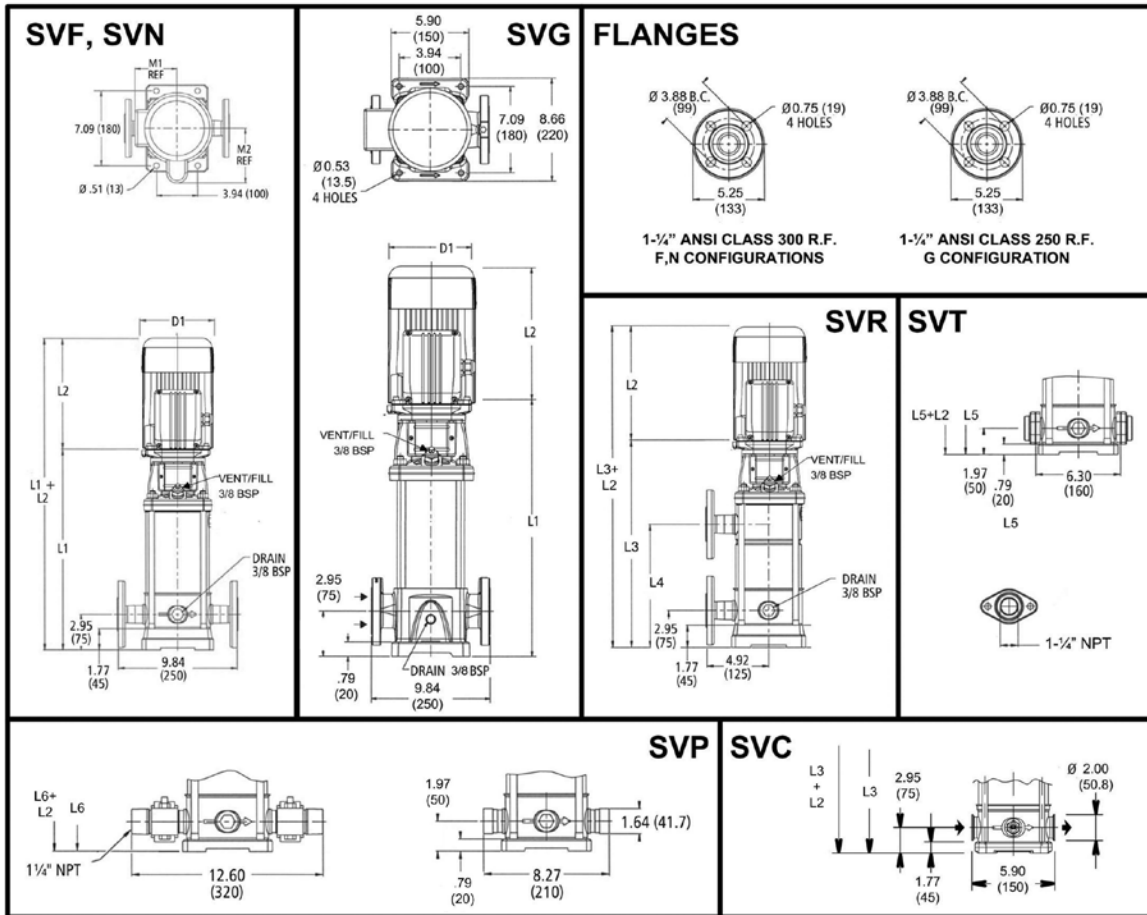

All dimensions are in inches (mm).

Pump Type Stages	HP	Motor				Dimensions (in)											Weight (lbs.)												
		NEMA Frame				L2				D1 (max.)			D2	Pump	Motor				Pump/Motor										
		ODP 10	TEFC 10	ODP 30	TEFC 30	L1	ODP 10	TEFC 10	ODP 30	TEFC 30	L3	L4			L5	L6	M (Ref.)	ODP 10	TEFC 10	ODP 30	TEFC 30	ODP 10	TEFC 10	ODP 30	TEFC 30				
5SV-02	0.5	56C	184TC	182TC	184TC	13.86	10.79	9.91	9.16	9.29	-	-	12.88	12.88	5.19	6.19	6.19	6.19	6.19	4.13	25	27	29	21	21	52	54	46	46
5SV-03						13.86	10.79	9.91	9.16	9.29	-	-	12.88	12.88	5.19	6.19	6.19	6.19	4.13	26	27	29	21	21	53	55	47	47	
5SV-04	0.75					14.85	10.66	11.19	9.16	9.29	-	-	13.86	13.86	5.74	6.19	7.19	6.19	6.19	4.13	28	32	40	23	23	60	68	51	51
5SV-05						15.83	10.67	11.19	10.66	9.91	-	-	14.85	14.85	5.74	6.19	7.19	6.19	6.19	4.72	29	32	40	30	28	61	69	59	57
5SV-06	1					16.81	10.67	11.19	10.66	9.91	-	-	15.83	15.83	5.74	6.19	7.19	6.19	6.19	4.72	30	32	40	30	28	62	70	60	58
5SV-07						17.80	11.18	12.06	11.16	10.79	17.80	9.53	16.81	16.81	5.74	7.19	7.19	6.19	6.19	4.72	31	43	51	32	33	74	82	63	64
5SV-08	1.5					18.78	11.18	12.06	11.16	10.79	18.78	10.51	17.80	17.80	5.74	7.19	7.19	6.19	6.19	4.72	33	43	51	32	33	76	84	65	66
5SV-09						19.77	11.18	12.06	11.16	10.79	19.77	11.50	18.78	18.78	5.74	7.19	7.19	6.19	6.19	4.72	33	43	51	32	33	76	84	65	66
5SV-10	2					20.75	11.57	13.44	11.18	11.16	20.75	12.48	19.77	19.77	5.75	6.50	7.19	7.16	7.19	5.51	34	49	64	41	44	83	98	75	78
5SV-11						21.74	11.57	13.44	11.18	11.16	21.74	13.46	20.75	20.75	5.75	6.50	7.19	7.16	7.19	5.51	35	49	64	41	44	84	99	76	79
5SV-12						22.72	11.57	13.44	11.18	11.16	22.72	14.45	21.74	21.74	5.75	6.50	7.19	7.16	7.19	5.51	36	49	64	41	44	85	100	77	80
5SV-13	3					184TC	182TC	184TC	24.40	13.93	15.43	12.55	13.93	24.40	15.43	23.42	23.42	6.87	8.88	8.86	9.02	8.86	5.51	40	81	92	62	69	121
5SV-14		25.39	13.93	15.43	12.55				13.93	25.39	16.42	24.40	24.40	6.87	8.88	8.86	9.02	8.86	5.51	40	81	92	62	69	121	132	102	109	
5SV-15		26.37	13.93	15.43	12.55				13.93	26.37	17.40	25.39	25.39	6.87	8.88	8.86	9.02	8.86	5.51	41	81	92	62	69	122	133	103	110	
5SV-16		27.36	13.93	15.43	12.55				13.93	27.36	18.39	26.37	26.37	6.87	8.88	8.86	9.02	8.86	5.51	43	81	92	62	69	124	135	105	112	
5SV-17		28.54	13.93	15.43	12.55				13.93	28.54	19.37	27.55	27.55	6.87	8.88	8.86	9.02	8.86	5.51	45	81	92	62	69	126	137	107	114	
5SV-18		29.33	13.93	15.43	12.55				13.93	29.33	20.35	28.34	28.34	6.87	8.88	8.86	9.02	8.86	5.51	46	81	92	62	69	127	138	108	115	
5SV-19	5	213TC	184TC	30.51	13.88	15.53	13.93	15.43	30.51	21.34	29.52	29.52	8.05	8.89	10.62	8.88	8.86	5.51	47	100	120	75	85	147	167	122	132		
5SV-20				31.69	13.88	15.53	13.93	15.43	31.69	22.32	30.70	30.70	8.05	8.89	10.62	8.88	8.86	5.51	48	100	120	75	85	148	168	123	133		
5SV-21				32.28	13.88	15.53	13.93	15.43	32.28	23.31	31.29	31.29	8.05	8.89	10.62	8.88	8.86	5.51	49	100	120	75	85	149	169	124	134		
5SV-22				33.34	13.88	15.53	13.93	15.43	33.34	24.29	-	32.36	8.05	8.89	10.62	8.88	8.86	5.51	50	100	120	75	85	150	170	125	135		
5SV-23				34.25	13.88	15.53	13.93	15.43	34.25	25.28	-	33.26	8.05	8.89	10.62	8.88	8.86	5.51	51	100	120	75	85	151	171	126	136		
5SV-24				35.31	13.88	15.53	13.93	15.43	35.31	26.26	-	34.33	8.05	8.89	10.62	8.88	8.86	5.51	53	100	120	75	85	153	173	128	138		
5SV-25				36.21	13.88	15.53	13.93	15.43	36.21	27.24	-	35.23	8.05	8.89	10.62	8.88	8.86	5.51	53	100	120	75	85	153	173	128	138		
5SV-26				37.28	13.88	15.53	13.93	15.43	37.28	28.23	-	36.29	8.05	8.89	10.62	8.88	8.86	5.51	54	100	120	75	85	154	174	129	139		
5SV-27				38.26	13.88	15.53	13.93	15.43	38.26	29.21	-	37.28	8.05	8.89	10.62	8.88	8.86	5.51	55	100	120	75	85	155	175	130	140		

Performance Curve

5SV 2900 RPM

50 Hz

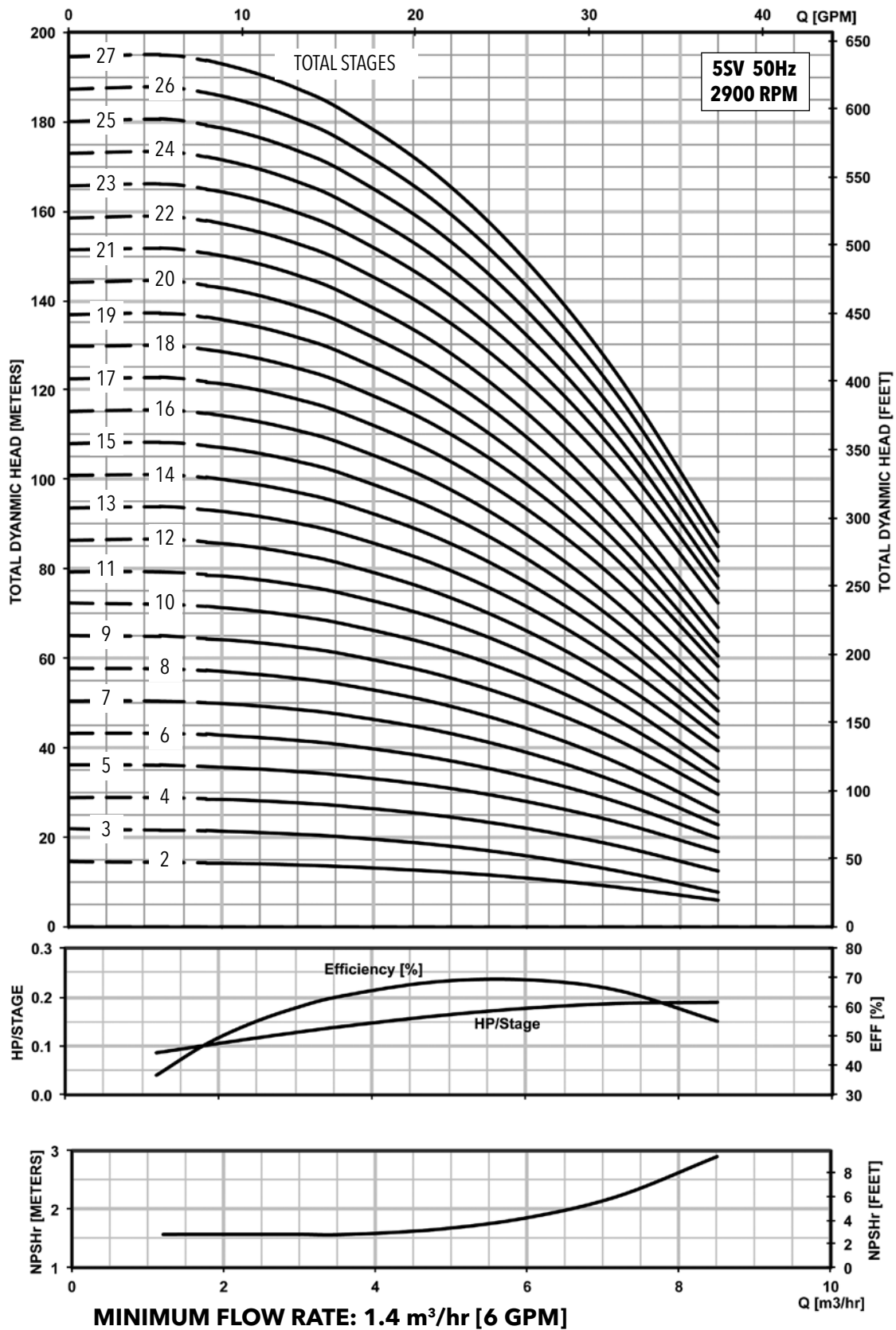

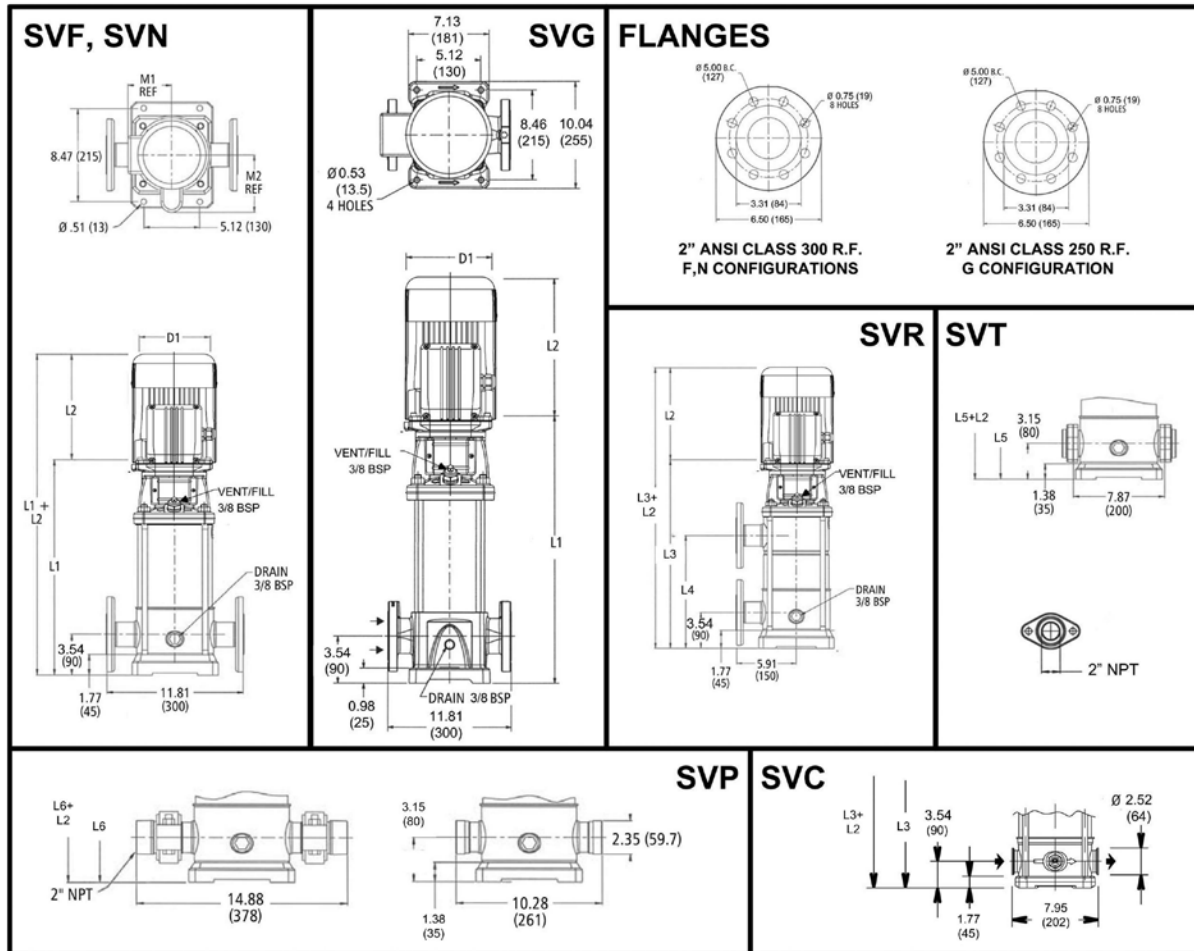

All dimensions are in inches (mm).

Pump Type Stages	Motor				Dimensions (in)												Weight (lbs.)												
	HP	NEMA Frame			L2				L3	L4	L5	L6	M (Ref.)	D1 (max.)				D2	Pump	Motor				Pump/Motor					
		ODP 1Ø	TEFC 1Ø	ODP 3Ø	TEFC 3Ø	L1	ODP 1Ø	TEFC 1Ø						ODP 3Ø	TEFC 3Ø	ODP 1Ø	TEFC 1Ø			ODP 3Ø	TEFC 3Ø	ODP 1Ø	TEFC 1Ø	ODP 3Ø	TEFC 3Ø	ODP 1Ø	TEFC 1Ø	ODP 3Ø	TEFC 3Ø
10SV-01	0.5	56C			16.56	10.79	9.91	9.16	9.29	-	-	16.17	16.17	5.19	6.19	6.19	6.19	6.19	4.13	36	27	29	21	21	63	65	57	57	
10SV-02	1	56C			16.56	10.67	11.19	10.66	9.91	-	-	16.17	16.17	5.74	6.19	7.19	6.19	6.19	4.72	38	32	40	30	28	70	78	68	66	
10SV-03	1.5	56C			17.82	11.18	12.06	11.16	10.79	-	-	17.43	17.43	5.74	7.19	7.19	6.19	6.19	4.72	40	43	51	32	33	83	91	72	73	
10SV-04	2	56C			19.08	11.57	13.44	11.18	11.16	-	-	18.69	18.69	5.75	6.50	7.19	7.16	7.19	5.51	43	49	64	41	44	92	107	84	87	
10SV-05	3	184TC	182TC	184TC	20.84	13.93	15.43	12.55	13.93	20.84	10.20	20.45	20.45	6.87	8.88	8.86	9.02	8.86	5.51	48	81	92	62	69	129	140	110	117	
10SV-06					22.10	13.93	15.43	12.55	13.93	22.10	11.46	21.71	21.71	6.87	8.88	8.86	9.02	8.86	5.51	50	81	92	62	69	131	142	112	119	
10SV-07					23.36	13.93	15.43	12.55	13.93	23.36	12.72	22.97	22.97	6.87	8.88	8.86	9.02	8.86	5.51	52	81	92	62	69	133	144	114	121	
10SV-08	5	213TC	184TC	24.62	13.88	15.53	13.93	15.43	24.62	13.98	24.22	24.22	8.05	8.89	10.62	8.88	8.86	5.51	54	100	120	75	85	154	174	129	139		
10SV-09				25.88	13.88	15.53	13.93	15.43	25.88	15.24	25.48	25.48	8.05	8.89	10.62	8.88	8.86	5.51	56	100	120	75	85	156	176	131	141		
10SV-10				27.14	13.88	15.53	13.93	15.43	27.14	16.50	26.74	26.74	8.05	8.89	10.62	8.88	8.86	5.51	59	100	120	75	85	159	179	134	144		
10SV-11				28.40	13.88	15.53	13.93	15.43	28.40	17.76	28.00	28.00	8.05	8.89	10.62	8.88	8.86	5.51	61	100	120	75	85	161	181	136	146		
10SV-12				28.87	13.88	15.53	13.93	15.43	28.87	19.02	28.48	28.48	8.05	8.89	10.62	8.88	8.86	5.51	63	100	120	75	85	163	183	138	148		
10SV-13	7.5	215TC	215TC	213TC	215TC	31.51	16.63	16.68	15.55	15.51	31.51	20.28	31.11	8.77	10.62	10.18	10.18	10.28	5.51	75	132	145	107	122	207	220	182	197	
10SV-14						32.85	16.63	16.68	15.55	15.51	32.85	21.54	-	32.45	8.77	10.62	10.18	10.18	10.28	5.51	77	132	145	107	122	209	222	184	199
10SV-15						34.03	16.63	16.68	15.55	15.51	34.03	22.80	-	33.63	8.77	10.62	10.18	10.18	10.28	5.51	79	132	145	107	122	211	224	186	201
10SV-16						35.29	16.63	16.68	15.55	15.51	35.29	24.06	-	34.89	8.77	10.62	10.18	10.18	10.28	5.51	81	132	145	107	122	213	226	188	203
10SV-17						36.55	16.63	16.68	15.55	15.51	36.55	25.31	-	36.15	8.77	10.62	10.18	10.18	10.28	5.51	83	132	145	107	122	215	228	190	205
10SV-18						37.81	16.63	16.68	15.55	15.51	37.81	26.57	-	37.41	8.77	10.62	10.18	10.18	10.28	5.51	85	132	145	107	122	217	230	192	207
10SV-19	10	-	-	215TC	254TC	39.78	-	-	15.55	16.57	39.78	27.83	-	39.38	9.22	-	-	10.18	10.28	5.51	92	-	-	125	195	-	-	217	287
10SV-20						40.96	-	-	15.55	16.57	40.96	29.09	-	40.56	9.22	-	-	10.18	10.28	5.51	94	-	-	125	195	-	-	219	289

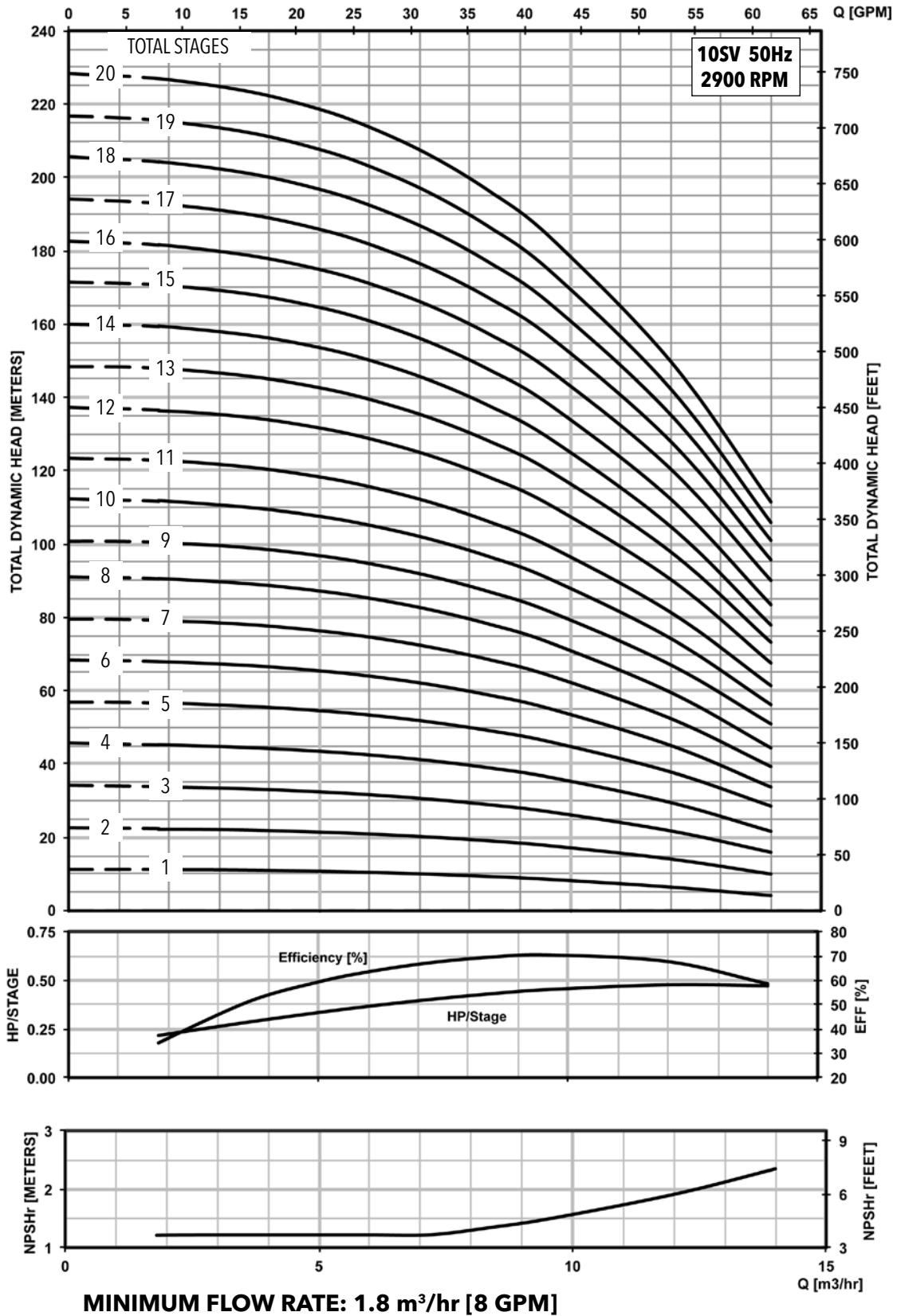

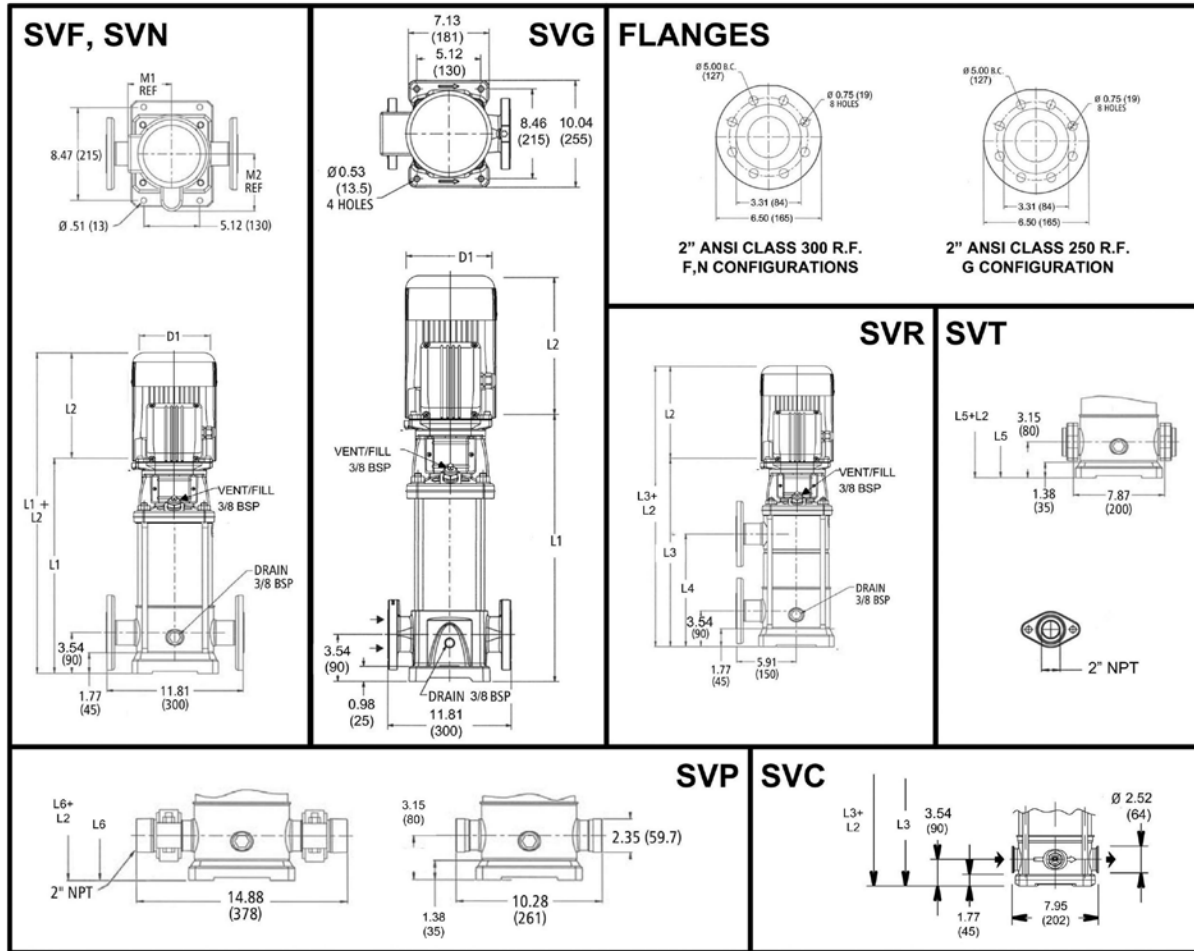

All dimensions are in inches (mm).

Pump Type Stages	Motor				Dimensions (in)													Weight (lbs.)										
	HP	NEMA Frame			L2				L3	L4	L5	L6	M (Ref.)	D1 (max.)				D2	Pump	Motor				Pump/Motor				
		ODP 10	TEFC 10	ODP 30	TEFC 30	L1	ODP 10	TEFC 10						ODP 30	TEFC 30	ODP 10	TEFC 10			ODP 30	TEFC 30	ODP 10	TEFC 10	ODP 30	TEFC 30	ODP 10	TEFC 10	ODP 30
15SV-01	1	56C			18.21	10.67	11.19	10.66	9.91	-	-	17.82	17.82	5.74	6.19	7.19	6.19	6.19	4.72	37	32	40	30	28	69	77	67	65
15SV-02	2	56C			18.21	11.57	13.44	11.18	11.16	-	-	17.82	17.82	5.75	6.50	7.19	7.16	7.19	5.51	41	49	64	41	44	90	105	82	85
15SV-03	3	184TC	182TC	184TC	20.60	13.93	15.43	12.55	13.93	-	-	20.21	20.21	6.87	8.88	8.86	9.02	8.86	5.51	47	81	92	62	69	128	139	109	116
15SV-04	5	213TC	184TC		22.49	13.88	15.53	13.93	15.43	22.49	11.85	22.10	22.10	8.05	8.89	10.62	8.88	8.86	5.51	50	100	120	75	85	150	170	125	135
15SV-05					24.38	13.88	15.53	13.93	15.43	24.38	13.74	23.99	23.99	8.05	8.89	10.62	8.88	8.86	5.51	52	100	120	75	85	152	172	127	137
15SV-06	7.5	215TC	213TC	215TC	26.86	16.63	16.68	15.55	15.51	26.86	15.63	26.47	26.47	8.77	10.62	10.18	10.18	10.28	5.51	66	132	145	107	122	198	211	173	188
15SV-07					28.75	16.63	16.68	15.55	15.51	28.75	17.52	28.36	28.36	8.77	10.62	10.18	10.18	10.28	5.51	69	132	145	107	122	201	214	176	191
15SV-08					30.64	16.63	16.68	15.55	15.51	30.64	19.41	30.25	30.25	8.77	10.62	10.18	10.18	10.28	5.51	71	132	145	107	122	203	216	178	193
15SV-09	10	-	215TC	254TC	33.16	-	-	15.55	16.57	33.16	21.30	32.77	32.77	9.22	-	-	10.18	10.28	5.51	79	-	-	125	195	-	-	204	274
15SV-10					35.05	-	-	15.55	16.57	35.05	23.19	34.66	34.66	9.22	-	-	10.18	10.28	5.51	83	-	-	125	195	-	-	208	278
15SV-11					36.94	-	-	15.55	16.57	36.94	25.08	-	36.55	9.22	-	-	10.18	10.28	5.51	86	-	-	125	195	-	-	211	281
15SV-12	15	-	254TC	256TC	38.83	-	-	16.66	20.08	38.83	26.97	-	38.44	9.50	-	-	10.18	13.13	5.51	89	-	-	144	285	-	-	233	374
15SV-13					40.72	-	-	16.66	20.08	40.72	28.86	-	40.33	9.50	-	-	10.18	13.13	5.51	92	-	-	144	285	-	-	236	377
15SV-14					42.61	-	-	16.66	20.08	42.61	30.75	-	42.22	9.50	-	-	10.18	13.13	5.51	95	-	-	144	285	-	-	239	380
15SV-15	44.50	-	-	16.66	20.08	44.50	32.64	-	44.11	9.50	-	-	10.18	13.13	5.51	98	-	-	144	285	-	-	242	383				

Performance Curve

15SV 2900 RPM

50 Hz

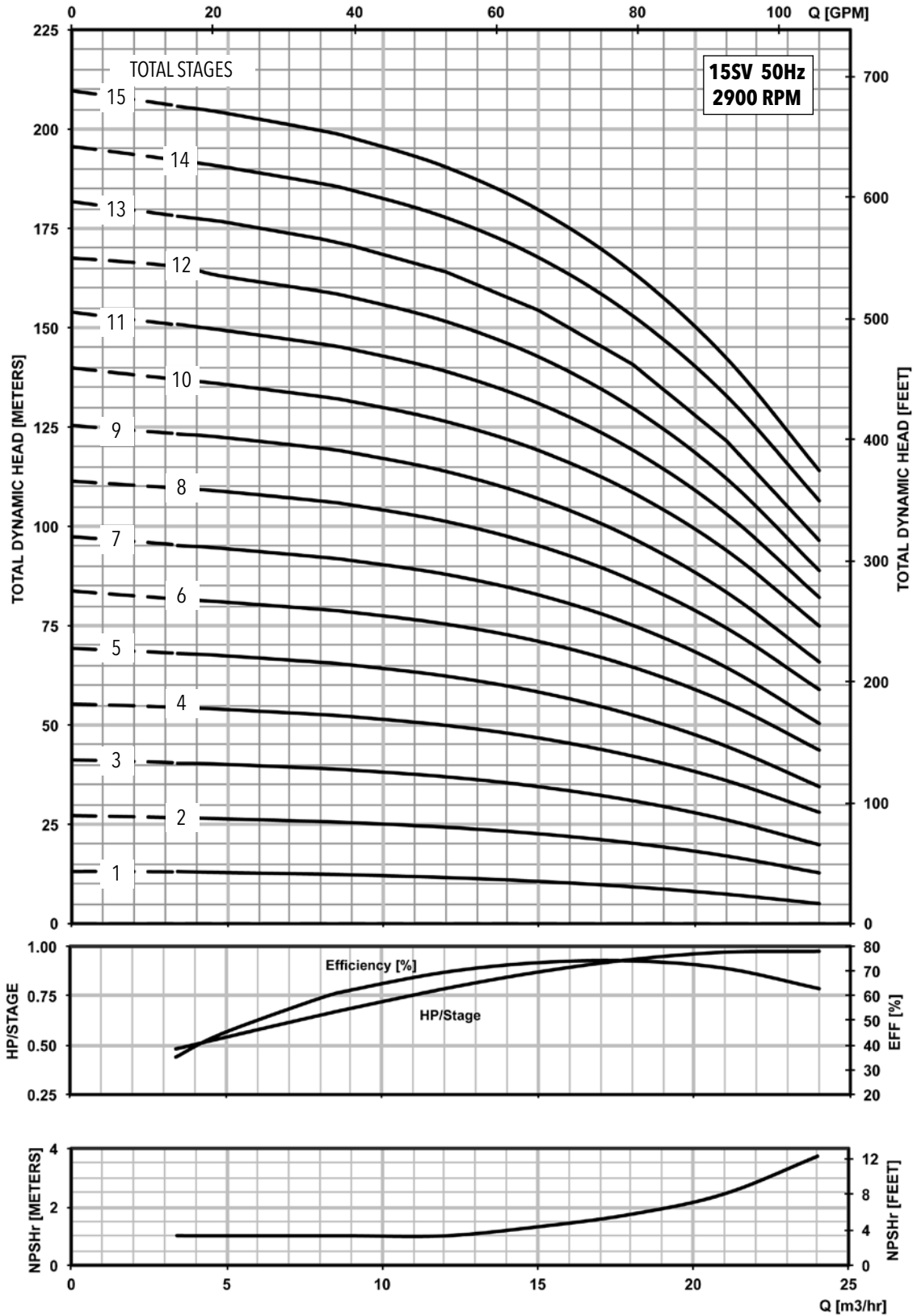

MINIMUM FLOW RATE: 3.4 m³/hr [15 GPM]

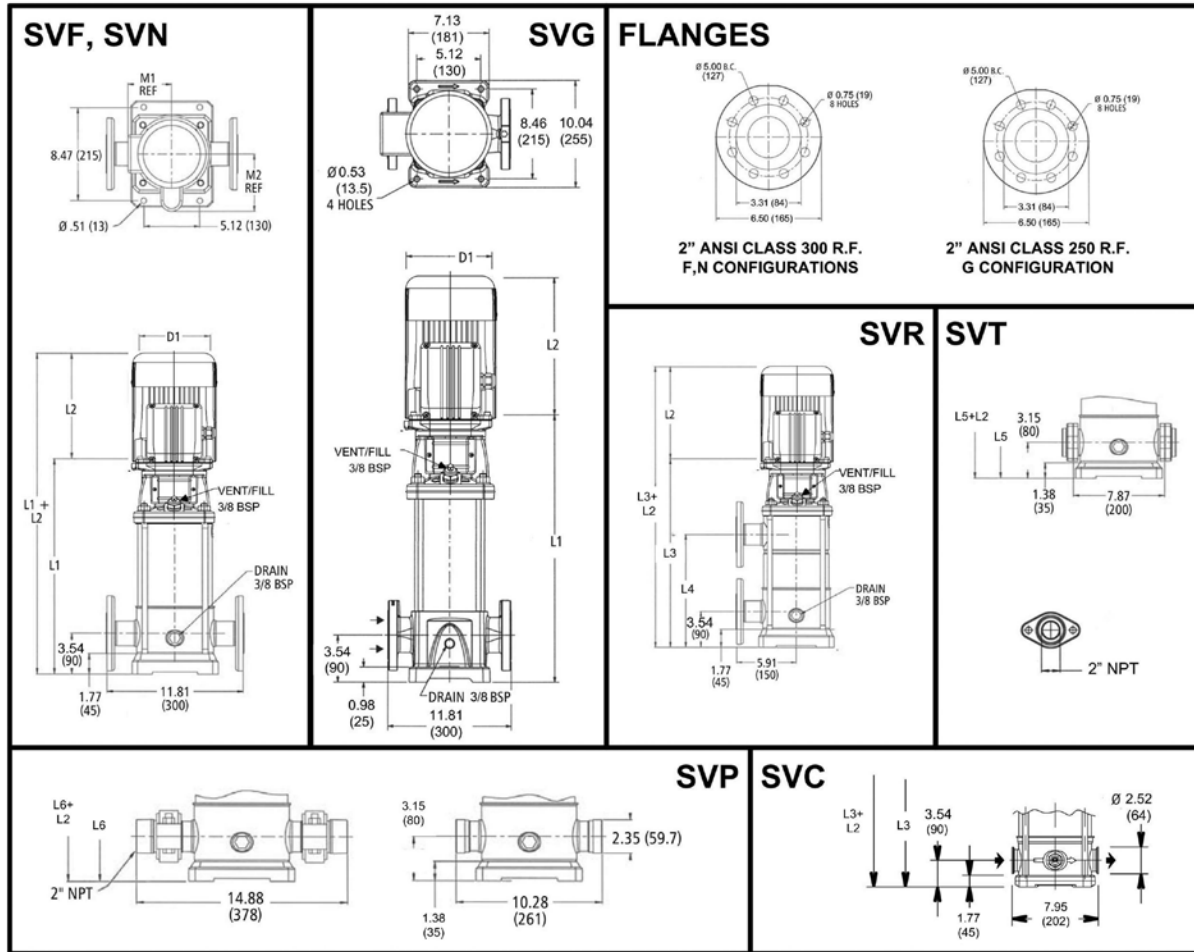

All dimensions are in inches (mm).

Pump Type Stages	HP	Motor				Dimensions (in)													Weight (lbs.)										
		NEMA Frame				L1	L2				L3	L4	L5	L6	M (Ref.)	D1 (max.)				D2	Pump	Motor				Pump/Motor			
		ODP 1Ø	TEFC 1Ø	ODP 3Ø	TEFC 3Ø		ODP 1Ø	TEFC 1Ø	ODP 3Ø	TEFC 3Ø						ODP 1Ø	TEFC 1Ø	ODP 3Ø	TEFC 3Ø			ODP 1Ø	TEFC 1Ø	ODP 3Ø	TEFC 3Ø	ODP 1Ø	TEFC 1Ø	ODP 3Ø	TEFC 3Ø
22SV01	1.5	56C				18.61	11.18	12.06	11.16	10.79	-	-	17.82	17.82	5.74	7.19	7.19	6.19	6.19	4.72	38	43	51	32	33	81	89	70	71
22SV02	3	184TC	182TC	184TC	18.71	13.93	15.43	12.55	13.93	-	-	18.32	18.32	6.87	8.88	8.86	9.02	8.86	5.51	45	81	92	62	69	126	137	107	114	
22SV03	5	213TC		184TC	20.60	13.88	15.53	13.93	15.43	-	-	20.21	20.21	8.05	8.89	10.62	8.88	8.86	5.51	48	100	120	75	85	148	168	123	133	
22SV04	5	213TC		184TC	22.49	13.88	15.53	13.93	15.43	22.49	11.85	22.10	22.10	8.05	8.89	10.62	8.88	8.86	5.51	51	100	120	75	85	151	171	126	136	
22SV05	7.5	215TC		215TC	24.97	16.63	16.68	15.55	15.51	24.97	13.74	24.58	24.58	8.77	10.62	10.18	10.18	10.28	5.51	61	132	145	107	122	193	206	168	183	
22SV06	7.5	215TC		215TC	26.86	16.63	16.68	15.55	15.51	26.86	15.63	26.47	26.47	8.77	10.62	10.18	10.18	10.28	5.51	64	132	145	107	122	196	209	171	186	
22SV07	10	215TC		254TC	29.38	-	-	15.55	16.57	29.38	17.52	28.99	28.99	9.22	-	-	10.18	10.28	5.51	72	-	-	125	195	-	-	197	267	
22SV08	10	215TC		254TC	31.27	-	-	15.55	16.57	31.27	19.41	30.88	30.88	9.22	-	-	10.18	10.28	5.51	75	-	-	125	195	-	-	200	270	
22SV09	15	254TC		256TC	33.16	-	-	16.66	20.08	33.16	21.30	32.77	32.77	9.50	-	-	10.18	13.13	5.51	77	-	-	144	285	-	-	221	362	
22SV10	15	254TC		256TC	35.05	-	-	16.66	20.08	35.05	23.19	34.66	34.66	9.50	-	-	10.18	13.13	5.51	81	-	-	144	285	-	-	225	366	
22SV11	15	254TC		256TC	36.94	-	-	16.66	20.08	36.94	25.08	-	36.55	9.50	-	-	10.18	13.13	5.51	84	-	-	144	285	-	-	228	369	
22SV12	15	254TC		256TC	38.83	-	-	16.66	20.08	38.83	26.97	-	38.44	9.50	-	-	10.18	13.13	5.51	87	-	-	144	285	-	-	231	372	

Performance Curve

22SV 2900 RPM

50 Hz

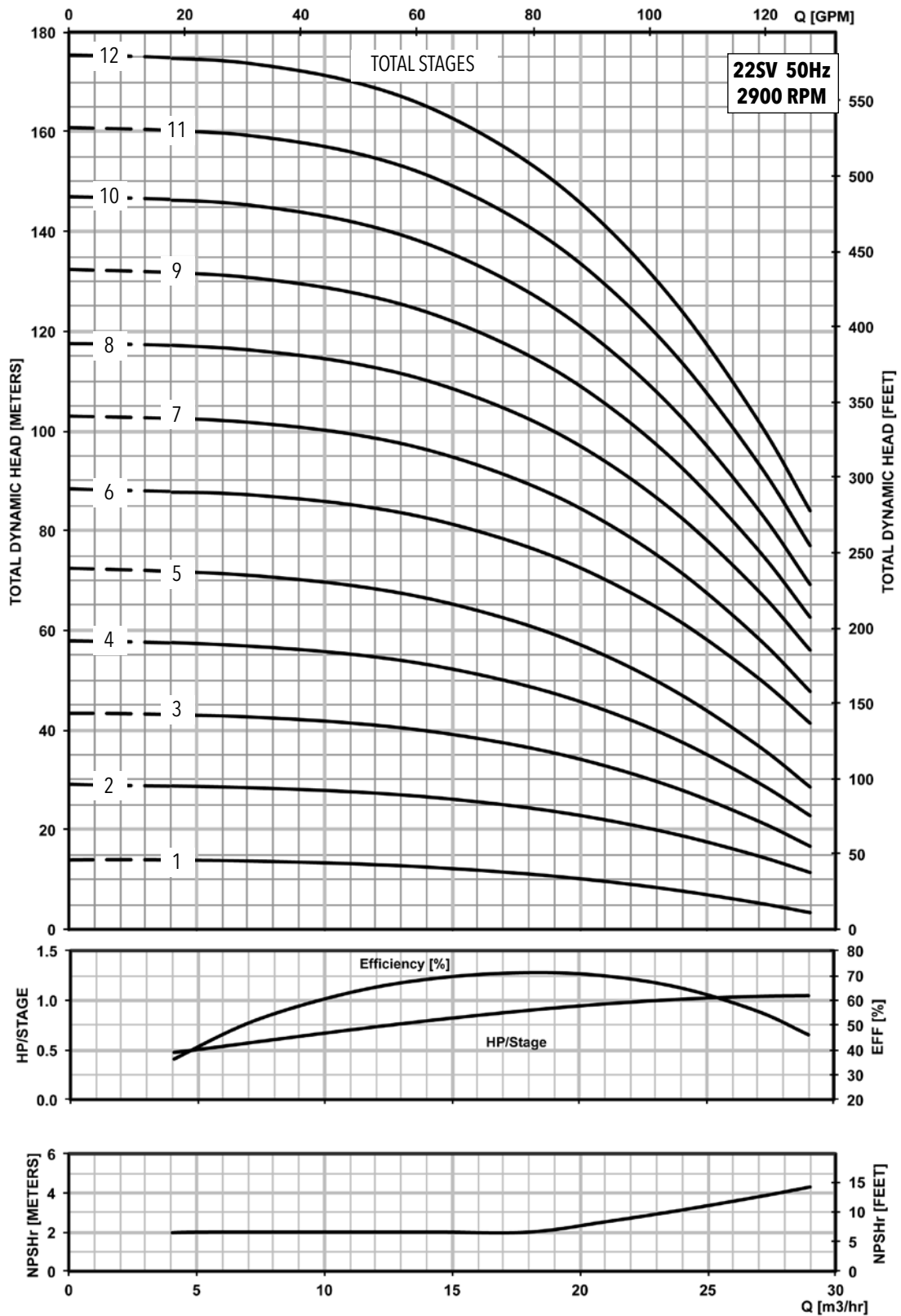

MINIMUM FLOW RATE: 4.1 m³/hr [18 GPM]

Dimensions and Weights

33SV Series 2900 RPM

50 Hz

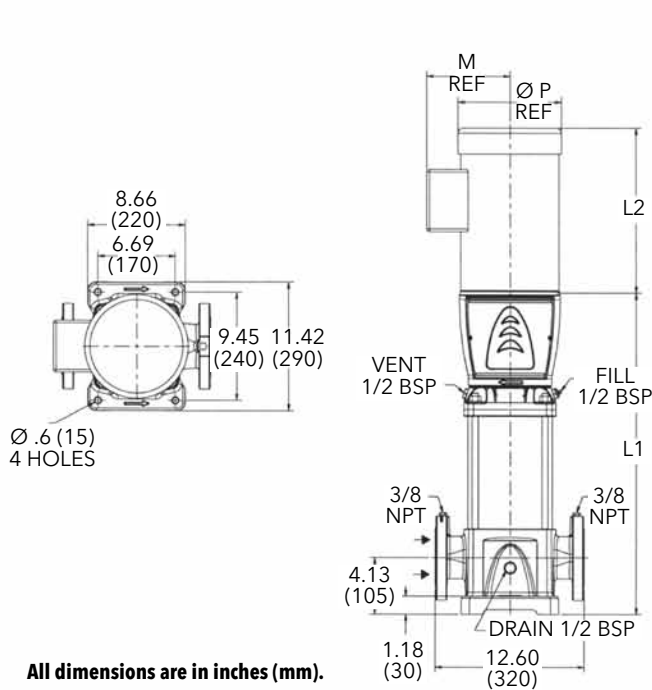

All dimensions are in inches (mm).

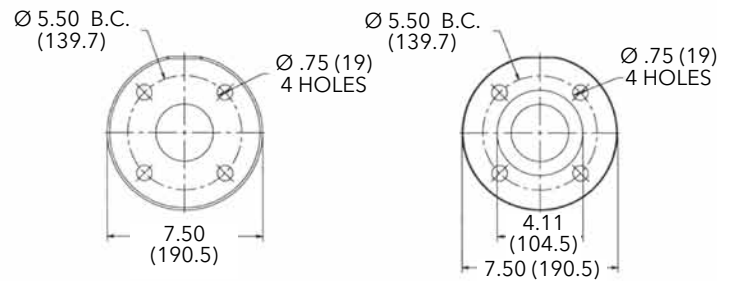

Cast Iron
2 1/2" Class 125 F.F.

316SS
2 1/2" Class 150 R.F.

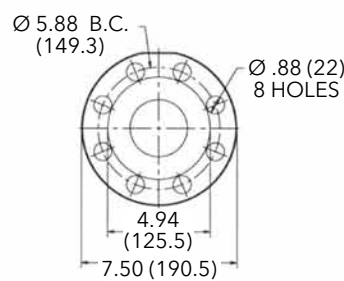

Cast Iron
2 1/2" Class 250 R.F.

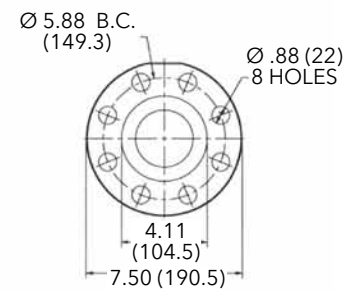

316SS
2 1/2" Class 300 R.F.

Pump Type Stages	Motor					Dimensions (in)										Weight (lbs.)									
	HP	NEMA Frame				L1	L2				M (Ref.)	D1 (max.)				D2	Pump Only	Motor				Pump/Motor			
		ODP 1Ø	TEFC 1Ø	ODP 3Ø	TEFC 3Ø		ODP 1Ø	TEFC 1Ø	ODP 3Ø	TEFC 3Ø		ODP 1Ø	TEFC 1Ø	ODP 3Ø	TEFC 3Ø			ODP 1Ø	TEFC 1Ø	ODP 3Ø	TEFC 3Ø	ODP 1Ø	TEFC 1Ø	ODP 3Ø	TEFC 3Ø
33SV-1	3	182TC	184TC	182TC	184TC	20.62	13.94	13.94	15.44	15.44	6.88	8.50	8.50	8.50	8.50	5.51	132	81	92	62	69	213	224	194	201
33SV-2/2	5	184TC				23.58	13.94	13.94	15.44	15.44	6.88	8.50	8.50	8.50	8.50	5.51	143	100	120	75	85	243	263	218	228
33SV-2/1						23.58	13.94	13.94	15.44	15.44	6.88	8.50	8.50	8.50	8.50	5.51	143	100	120	75	85	243	263	218	228
33SV-2	7.5	213TC			215TC	23.58	15.56	15.56	15.50	15.50	8.06	10.19	10.19	10.25	10.25	5.51	143	132	145	107	122	275	288	250	265
33SV-3/2					215TC	26.54	15.56	15.56	15.50	15.50	8.06	10.19	10.19	10.25	10.25	5.51	152	132	145	107	122	284	297	259	274
33SV-3/1					215TC	26.54	15.56	15.56	15.50	15.50	8.06	10.19	10.19	10.25	10.25	5.51	152	132	145	107	122	284	297	259	274
33SV-3	10	-	-	215TC	254TC	26.54	-	-	16.56	16.56	9.25	10.19	10.19	10.31	10.31	5.51	152	-	-	125	195	-	-	277	347
33SV-4/2		-	-			29.50	-	-	16.56	16.56	9.25	10.19	10.19	10.31	10.31	5.51	161	-	-	125	195	-	-	286	356
33SV-4/1		-	-	-	-	29.50	-	-	16.56	16.56	9.25	10.19	10.19	10.31	10.31	5.51	161	-	-	125	195	-	-	286	356
33SV-4		-	-	-	-	29.50	-	-	16.56	16.56	9.25	10.19	10.19	10.31	10.31	5.51	161	-	-	144	285	-	-	305	446
33SV-5/2	15	-	-	254TC	256TC	32.44	-	-	16.56	16.56	9.25	10.19	10.19	10.31	10.31	5.51	172	-	-	144	285	-	-	316	457
33SV-5/1		-	-			32.44	-	-	16.56	16.56	9.25	10.19	10.19	10.31	10.31	5.51	172	-	-	144	285	-	-	316	457
33SV-5		-	-			32.44	-	-	16.56	16.56	9.25	10.19	10.19	10.31	10.31	5.51	172	-	-	144	285	-	-	316	457
33SV-6/2		-	-	35.40	-	-	16.56	16.56	9.25	10.19	10.19	10.31	10.31	5.51	194	-	-	144	285	-	-	338	479		
33SV-6/1		-	-	-	-	35.40	-	-	23.38	23.38	13.12	11.63	11.63	15.31	15.31	5.51	194	-	-	185	283	-	-	379	477
33SV-6	20	-	-	256TC	284TC	35.40	-	-	23.38	23.38	13.12	11.63	11.63	15.31	15.31	5.51	194	-	-	185	283	-	-	379	477
33SV-7/2		-	-			38.35	-	-	23.38	23.38	13.12	11.63	11.63	15.31	15.31	5.51	204	-	-	185	283	-	-	389	487
33SV-7/1		-	-			38.35	-	-	23.38	23.38	13.12	11.63	11.63	15.31	15.31	5.51	204	-	-	185	283	-	-	389	487
33SV-7		-	-			38.35	-	-	23.38	23.38	13.12	11.63	11.63	15.31	15.31	5.51	204	-	-	185	283	-	-	389	487
33SV-8/2		-	-			41.30	-	-	23.38	23.38	13.12	11.63	11.63	15.31	15.31	5.51	221	-	-	185	283	-	-	406	504
33SV-8/1		-	-			41.30	-	-	23.38	23.38	13.12	13.25	13.25	15.31	15.31	5.51	221	-	-	296	382	-	-	517	603
33SV-8	25	-	-	256TC	284TC	41.30	-	-	23.38	23.38	13.12	13.25	13.25	15.31	15.31	5.51	221	-	-	296	382	-	-	517	603
33SV-9/2		-	-			44.25	-	-	23.38	23.38	13.12	13.25	13.25	15.31	15.31	5.51	230	-	-	296	382	-	-	526	612
33SV-9/1		-	-			44.25	-	-	23.38	23.38	13.12	13.25	13.25	15.31	15.31	5.51	230	-	-	296	382	-	-	526	612
33SV-9		-	-			44.25	-	-	23.38	23.38	13.12	13.25	13.25	15.31	15.31	5.51	230	-	-	296	382	-	-	526	612
33SV-10/2	30	-	-	284TC	284TC	47.20	-	-	23.38	23.38	13.12	13.25	13.25	15.31	15.31	5.51	249	-	-	315	446	-	-	564	695
33SV-10/1		-	-			47.20	-	-	23.38	23.38	13.12	13.25	13.25	15.31	15.31	5.51	249	-	-	315	446	-	-	564	695
33SV-10		-	-			47.20	-	-	23.38	23.38	13.12	13.25	13.25	15.31	15.31	5.51	249	-	-	315	446	-	-	564	695

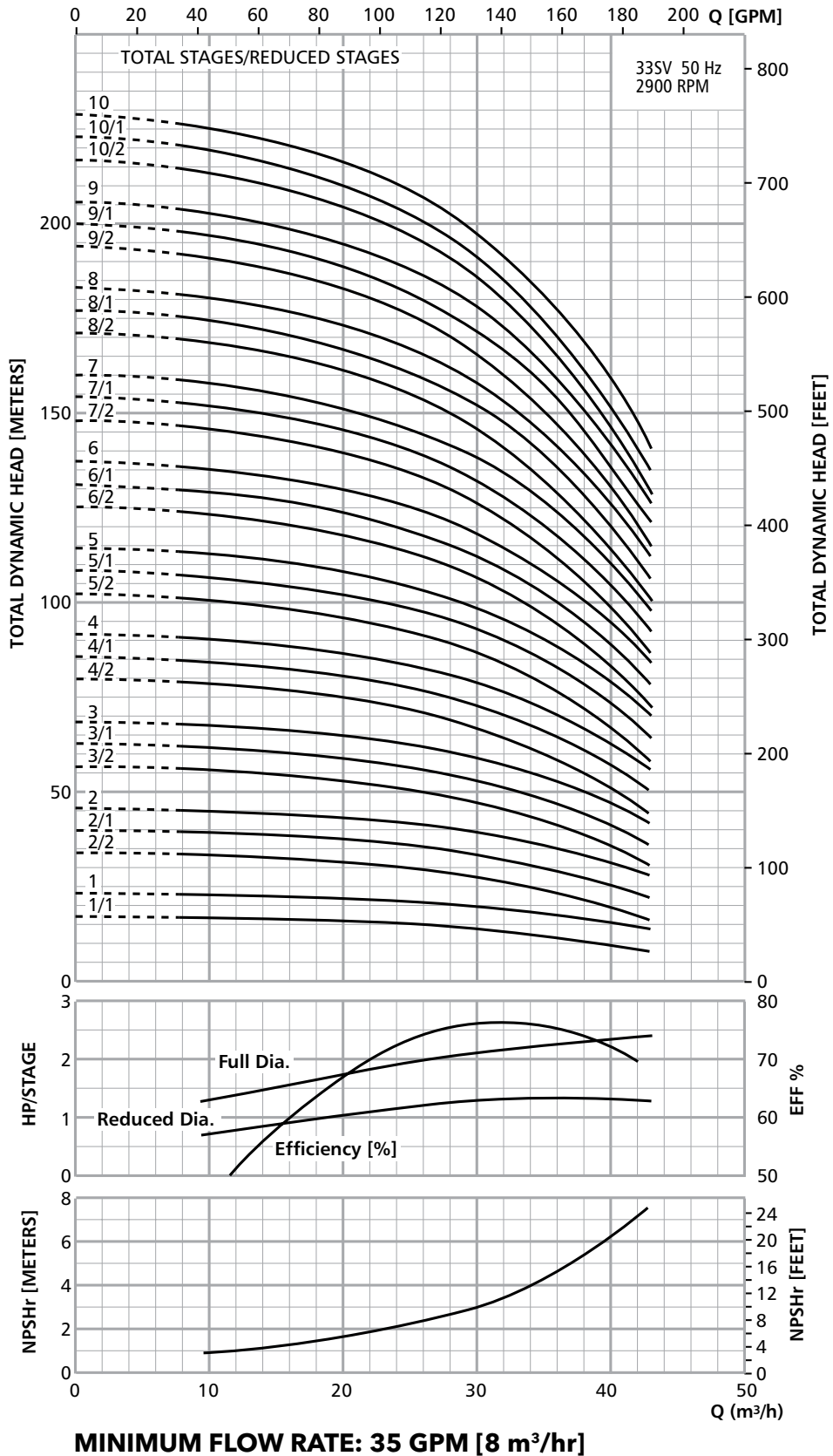

Dimensions and Weights

46SV Series 2900 RPM

50 Hz

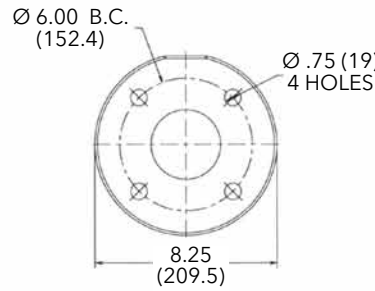
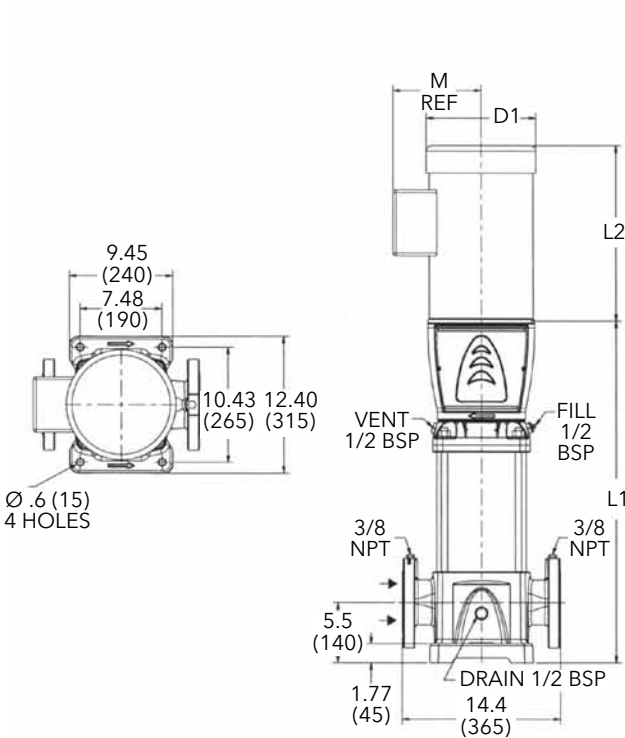

**Cast Iron
3" Class 125 F.F.**

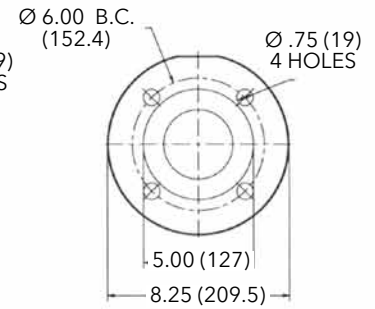

**316SS
3" Class 150 R.F.**

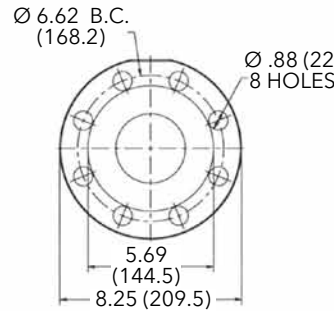

**Cast Iron
3" Class 250 R.F.**

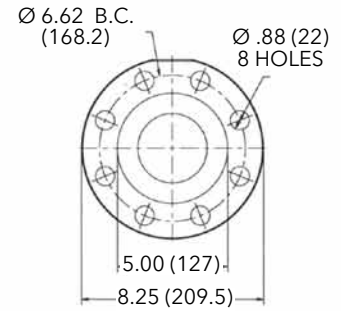

**316SS
3" Class 300 R.F.**

All dimensions are in inches (mm).

Pump Type Stages	Motor					Dimensions (in)										Weight (lbs.)									
	HP	NEMA Frame				L1	L2				M (Ref.)	D1 (max.)				D2	Pump Only	Motor				Pump/Motor			
		ODP 1Ø	TEFC 1Ø	ODP 3Ø	TEFC 3Ø		ODP 1Ø	TEFC 1Ø	ODP 3Ø	TEFC 3Ø		ODP 1Ø	TEFC 1Ø	ODP 3Ø	TEFC 3Ø			ODP 1Ø	TEFC 1Ø	ODP 3Ø	TEFC 3Ø	ODP 1Ø	TEFC 1Ø	ODP 3Ø	TEFC 3Ø
46SV-1	5	184TC				22.19	13.94	15.44	13.94	15.44	6.88	8.50	8.50	8.50	8.50	5.51	147	101	124	101	124	248	271	248	271
46SV-2/2		184TC				25.19	13.94	15.44	13.94	15.44	6.88	8.50	8.50	8.50	8.50	5.51	158	101	124	101	124	259	282	259	282
46SV-2/1	7.5	213TC			215TC	25.19	13.94	15.44	15.56	15.50	8.06	10.19	10.25	10.19	10.25	5.51	158	130	151	130	151	288	309	288	309
46SV-2	10	-	-	215TC	254TC	25.19	-	-	15.56	16.56	9.25	-	-	10.19	10.31	5.51	158	-	-	128	250	-	-	286	408
46SV-3/2		-	-	-	-	28.12	-	-	15.56	16.56	9.25	-	-	10.19	10.31	5.51	169	-	-	128	250	-	-	297	419
46SV-3/1	15	-	-	254TC	256TC	28.12	-	-	15.56	16.56	9.25	-	-	10.19	10.31	5.51	169	-	-	220	280	-	-	389	449
46SV-3		-	-			28.12	-	-	15.56	16.56	9.25	-	-	10.19	10.31	5.51	169	-	-	220	280	-	-	389	449
46SV-4/2	15	-	-	254TC	256TC	32.63	-	-	15.56	16.56	9.25	-	-	10.19	10.31	5.51	185	-	-	220	280	-	-	405	465
46SV-4/1		-	-			32.63	-	-	15.56	16.56	9.25	-	-	10.19	10.31	5.51	185	-	-	220	280	-	-	405	465
46SV-4	20	-	-	256TC	284TC	32.63	-	-	18.00	23.38	13.12	-	-	11.63	15.13	5.51	185	-	-	240	420	-	-	425	605
46SV-5/2		-	-			35.56	-	-	18.00	23.38	13.12	-	-	11.63	15.13	5.51	199	-	-	240	420	-	-	439	619
46SV-5/1	20	-	-	256TC	284TC	35.56	-	-	18.00	23.38	13.12	-	-	11.63	15.13	5.51	199	-	-	240	420	-	-	439	619
46SV-5		-	-			35.56	-	-	18.00	23.38	13.12	-	-	11.63	15.13	5.51	199	-	-	240	420	-	-	439	619
46SV-6/2	25	-	-	284TC	284TC	38.50	-	-	20.12	23.38	13.12	-	-	13.25	15.13	5.51	208	-	-	325	445	-	-	533	653
46SV-6/1		-	-			38.50	-	-	20.12	23.38	13.12	-	-	13.25	15.13	5.51	208	-	-	325	445	-	-	533	653
46SV-6	25	-	-	284TC	284TC	38.50	-	-	20.12	23.38	13.12	-	-	13.25	15.13	5.51	208	-	-	325	445	-	-	533	653
46SV-7/2		-	-			40.94	-	-	20.12	23.38	13.12	-	-	13.25	15.13	5.51	225	-	-	325	445	-	-	550	670
46SV-7/1	30	-	-	284TC	284TC	40.94	-	-	20.12	23.38	13.12	-	-	13.25	15.13	5.51	225	-	-	328	448	-	-	553	673
46SV-7		-	-			40.94	-	-	20.12	23.38	13.12	-	-	13.25	15.13	5.51	225	-	-	328	448	-	-	553	673
46SV-8/2	30	-	-	284TC	284TC	43.94	-	-	20.12	23.38	13.12	-	-	13.25	15.13	5.51	234	-	-	328	448	-	-	562	682
46SV-8/1		-	-			43.94	-	-	20.12	23.38	13.12	-	-	13.25	15.13	5.51	234	-	-	328	448	-	-	562	682
46SV-8	40	-	-	326TSC	326TSC	43.94	-	-	22.50	23.38	13.12	-	-	13.25	15.13	5.51	234	-	-	382	592	-	-	616	826
46SV-9/2		-	-			46.88	-	-	22.50	23.38	13.12	-	-	13.25	15.13	5.51	253	-	-	382	592	-	-	635	845
46SV-9/1	40	-	-	326TSC	326TSC	46.88	-	-	22.50	23.38	13.12	-	-	13.25	15.13	5.51	253	-	-	382	592	-	-	635	845
46SV-9		-	-			46.88	-	-	22.50	23.38	13.12	-	-	13.25	15.13	5.51	253	-	-	382	592	-	-	635	845
46SV-10/2	40	-	-	326TSC	326TSC	49.81	-	-	22.50	23.38	13.12	-	-	13.25	15.13	5.51	264	-	-	382	592	-	-	646	856

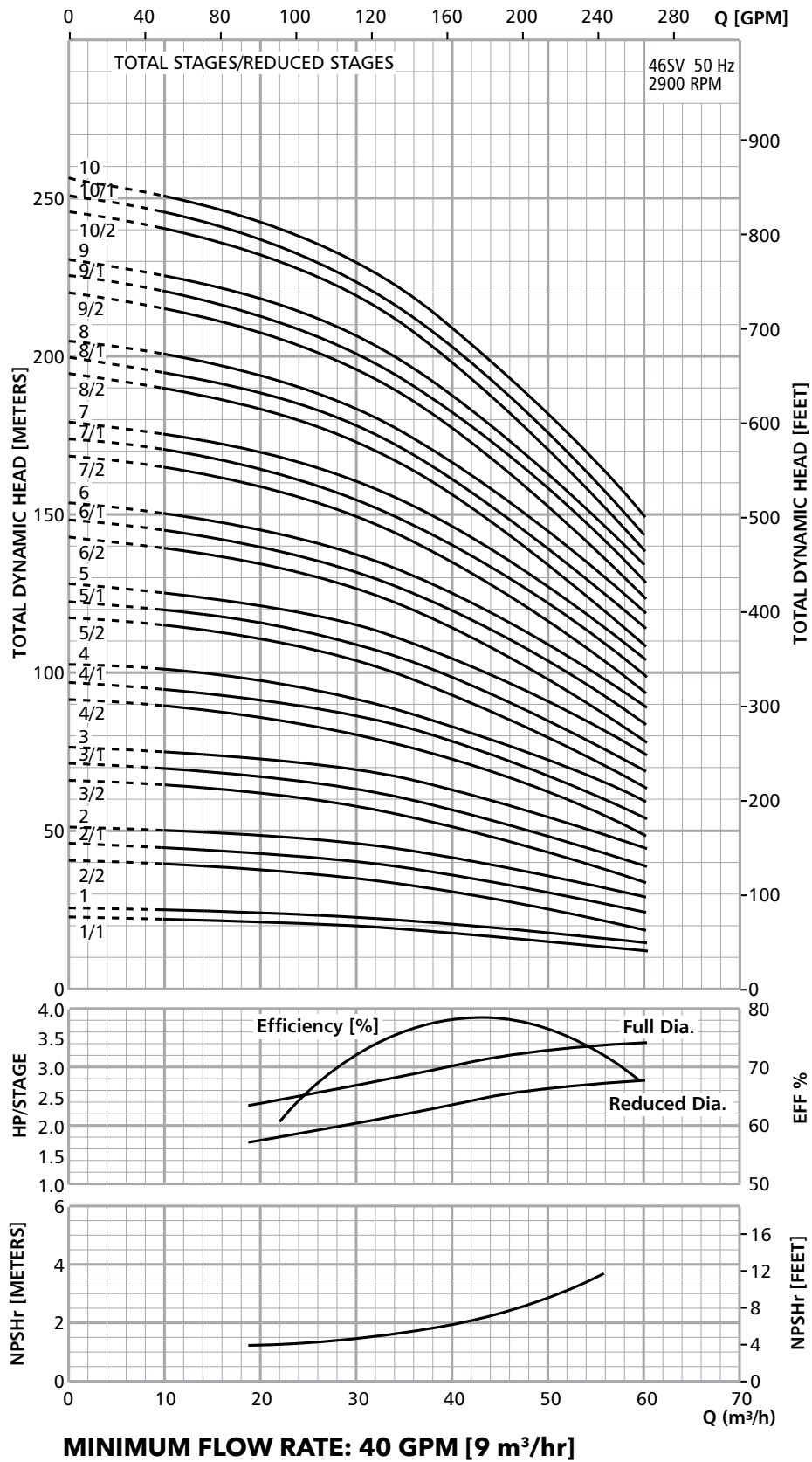

Dimensions and Weights

66SV Series 2900 RPM

50 Hz

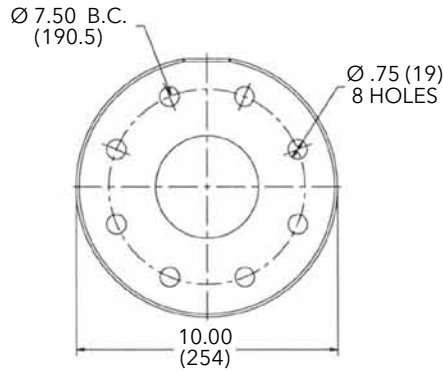
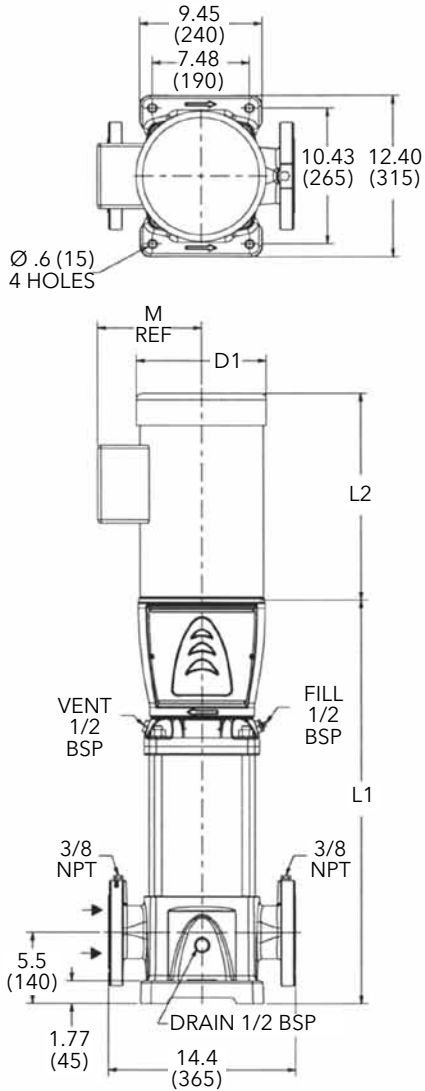

Cast Iron
4" Class 125 F.F.

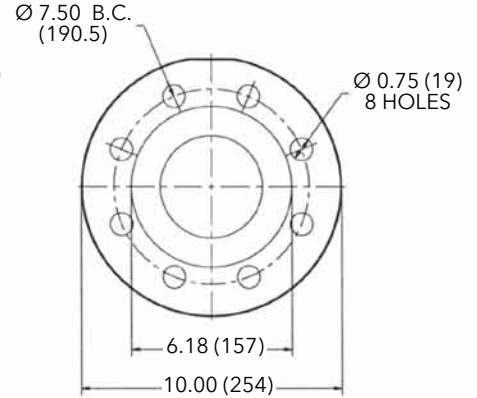

316SS
4" Class 150 R.F.

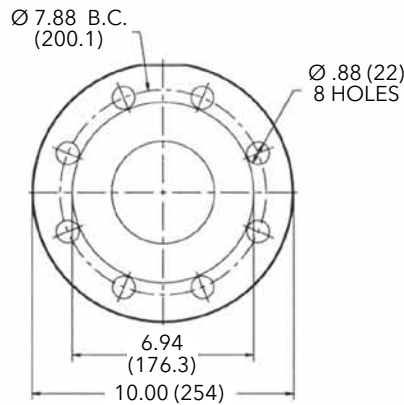

Cast Iron
4" Class 250 R.F.

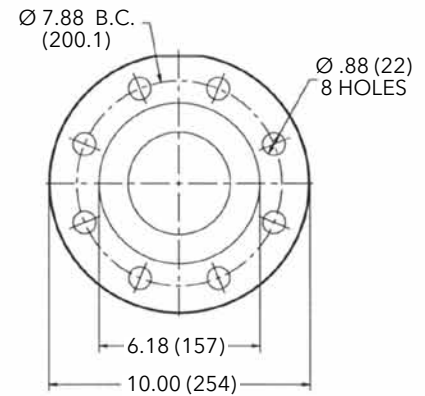

316SS
4" Class 300 R.F.

All dimensions are in inches (mm).

Pump Type Stages	Motor				Dimensions (in)										Weight (lbs.)										
	HP	NEMA Frame			L1	L2				M (Ref.)	D1 (max.)				D2	Pump Only	Motor				Pump/Motor				
		ODP 1Ø	TEFC 1Ø	ODP 3Ø		TEFC 3Ø	ODP 1Ø	TEFC 1Ø	ODP 3Ø		TEFC 3Ø	ODP 1Ø	TEFC 1Ø	ODP 3Ø			TEFC 3Ø	ODP 1Ø	TEFC 1Ø	ODP 3Ø	TEFC 3Ø	ODP 1Ø	TEFC 1Ø	ODP 3Ø	TEFC 3Ø
66SV-1	7.5	213TC			215TC	23.19	15.60	15.50	15.60	15.50	8.06	10.19	10.25	10.19	10.25	5.51	185	130	151	130	151	315	336	315	336
66SV-2/2	10	-	-	215TC	254TC	26.75	-	-	15.60	16.56	9.25	-	-	10.19	10.31	5.51	196	-	-	128	280	-	-	324	476
66SV-2/1	15	-	-	254TC	256TC	26.75	-	-	15.60	16.56	9.25	-	-	10.19	10.31	5.51	196	-	-	220	280	-	-	416	476
66SV-2		-	-			26.75	-	-	15.60	16.56	9.25	-	-	10.19	10.31	5.51	196	-	-	220	280	-	-	416	476
66SV-3/2		-	-			31.81	-	-	15.60	16.56	9.25	-	-	10.19	10.31	5.51	223	-	-	220	280	-	-	443	503
66SV-3/1	20	-	-	256TC	284TC	31.81	-	-	18.00	23.38	13.12	-	-	11.63	15.31	5.51	223	-	-	240	420	-	-	463	643
66SV-3		-	-			31.81	-	-	18.00	23.38	13.12	-	-	11.63	15.31	5.51	223	-	-	240	420	-	-	463	643
66SV-4/2		-	-			35.38	-	-	20.12	23.38	13.12	-	-	13.25	15.31	5.51	234	-	-	325	445	-	-	559	679
66SV-4/1	25	-	-	284TC	326TSC	35.38	-	-	20.12	23.38	13.12	-	-	13.25	15.31	5.51	234	-	-	325	445	-	-	559	679
66SV-4		-	-			35.38	-	-	20.12	23.38	13.12	-	-	13.25	15.31	5.51	234	-	-	325	445	-	-	559	679
66SV-5/2		-	-			39.44	-	-	20.12	23.38	13.12	-	-	13.25	15.31	5.51	244	-	-	328	448	-	-	572	692
66SV-5/1	30	-	-	284TC	326TSC	39.44	-	-	20.12	23.38	13.12	-	-	13.25	15.31	5.51	244	-	-	328	448	-	-	572	692
66SV-5		-	-			39.44	-	-	20.12	23.38	13.12	-	-	13.25	15.31	5.51	244	-	-	328	448	-	-	572	692
66SV-6/2		-	-			41.94	-	-	22.50	23.38	13.12	-	-	13.25	15.31	5.51	266	-	-	382	592	-	-	648	858
66SV-6/1	40	-	-	324TSC	326TSC	41.94	-	-	22.50	23.38	13.12	-	-	13.25	15.31	5.51	266	-	-	382	592	-	-	648	858
66SV-6		-	-			41.94	-	-	22.50	23.38	13.12	-	-	13.25	15.31	5.51	266	-	-	382	592	-	-	648	858

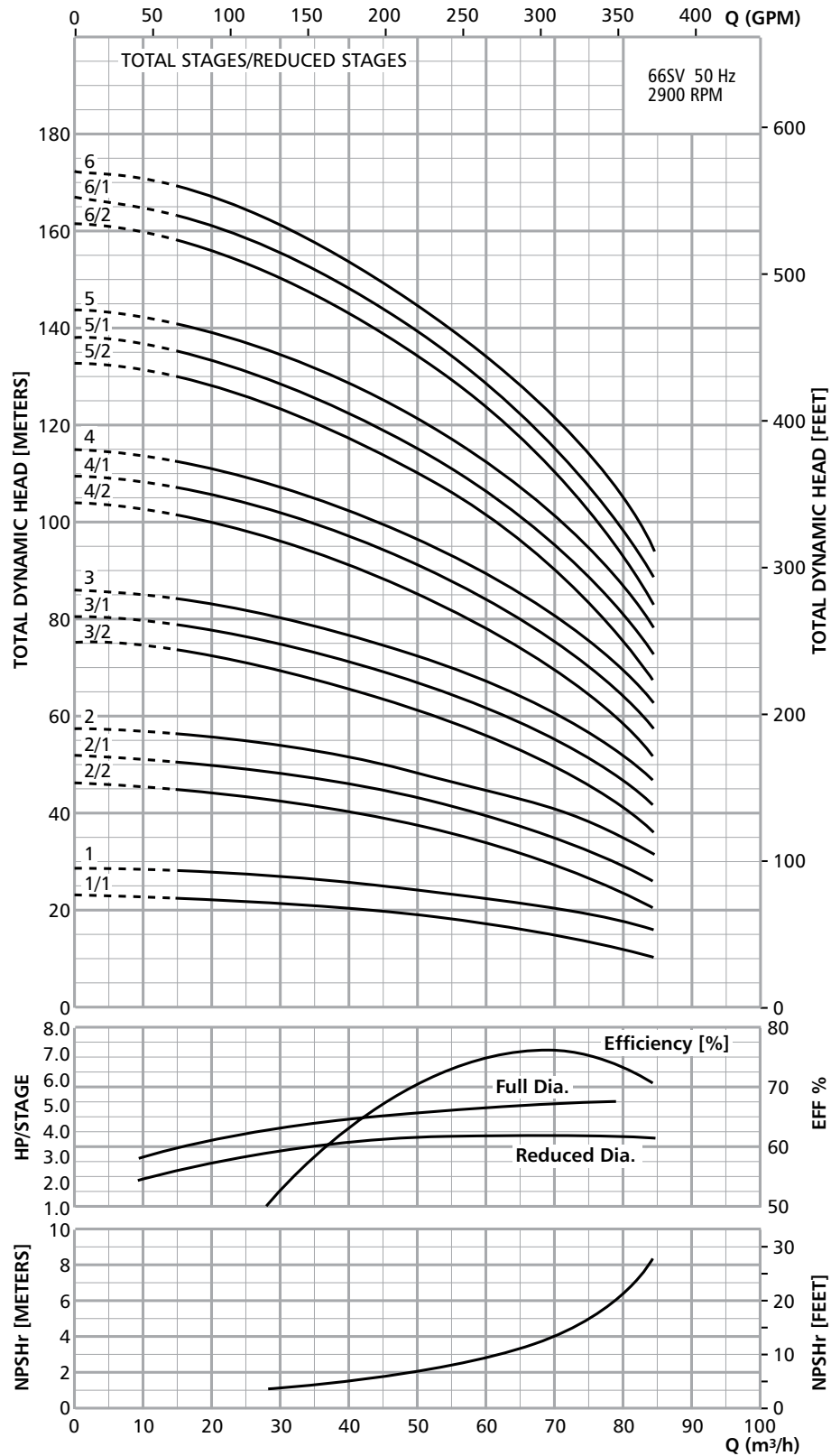

MINIMUM FLOW RATE: 70 GPM [16 m³/hr]

Dimensions and Weights

92SV Series 2900 RPM

50 Hz

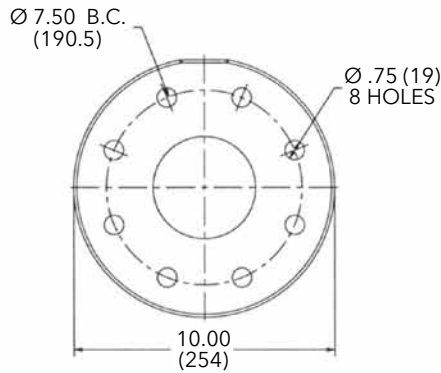
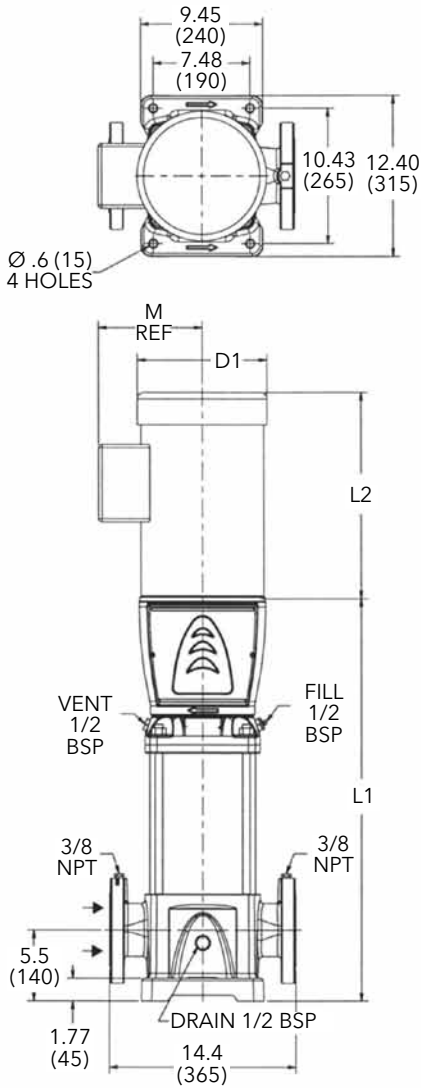

Cast Iron
4" Class 125 F.F.

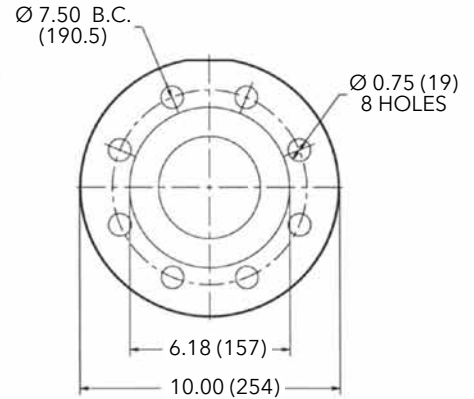

316SS
4" Class 150 R.F.

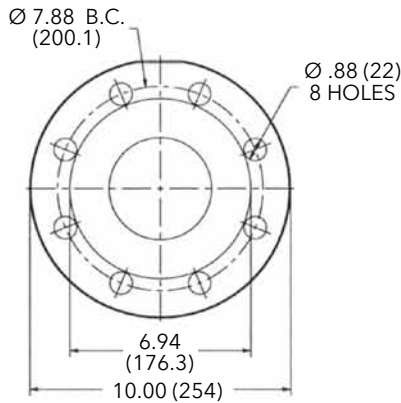

Cast Iron
4" Class 250 R.F.

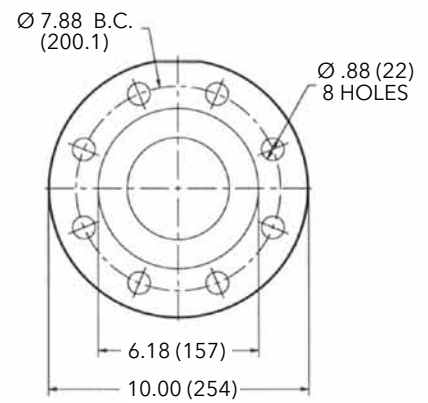

316SS
4" Class 300 R.F.

All dimensions are in inches (mm).

Pump Type Stages	HP	Motor				Dimensions (in)										Weight (lbs.)									
		NEMA Frame				L1	L2				M (Ref.)	D1 (max.)				D2	Pump Only	Motor				Pump/Motor			
		ODP 1Ø	TEFC 1Ø	ODP 3Ø	TEFC 3Ø		ODP 1Ø	TEFC 1Ø	ODP 3Ø	TEFC 3Ø		ODP 1Ø	TEFC 1Ø	ODP 3Ø	TEFC 3Ø			ODP 1Ø	TEFC 1Ø	ODP 3Ø	TEFC 3Ø	ODP 1Ø	TEFC 1Ø	ODP 3Ø	TEFC 3Ø
92SV-1	10	-	-	215TC	254TC	23.19	-	-	15.60	16.56	9.25	-	-	10.19	10.31	5.51	185	-	-	128	250	-	-	313	435
92SV-2/2	15	-	-	254TC	256TC	28.31	-	-	15.60	16.56	9.25	-	-	10.19	10.31	5.51	196	-	-	220	280	-	-	416	476
92SV-2/1		-	-			28.31	-	-	15.60	16.56	9.25	-	-	10.19	10.31	5.51	196	-	-	220	280	-	-	416	476
92SV-2	20	-	-	256TC	284TC	28.31	-	-	18.00	23.38	13.12	-	-	11.63	15.31	5.51	196	-	-	240	420	-	-	436	616
92SV-3/2		-	-			31.18	-	-	18.00	23.38	13.12	-	-	11.63	15.31	5.51	223	-	-	240	420	-	-	463	643
92SV-3/1	25	-	-	284TC	284TC	31.18	-	-	20.12	23.38	13.12	-	-	13.25	15.31	5.51	223	-	-	325	445	-	-	548	668
92SV-3		-	-			31.28	-	-	20.12	23.38	13.12	-	-	13.25	15.31	5.51	223	-	-	325	445	-	-	548	668
92SV-4/2	30	-	-	284TC	284TC	34.88	-	-	20.12	23.38	13.12	-	-	13.25	15.31	5.51	234	-	-	328	448	-	-	562	682
92SV-4/1		-	-			34.88	-	-	20.12	23.38	13.12	-	-	13.25	15.31	5.51	234	-	-	328	448	-	-	562	682
92SV-4	40	-	-	324TSC	326TSC	34.88	-	-	22.50	23.38	13.12	-	-	13.25	15.31	5.51	234	-	-	382	592	-	-	616	826
92SV-5/2		-	-			38.44	-	-	22.50	23.38	13.12	-	-	13.25	15.31	5.51	252	-	-	382	592	-	-	634	844
92SV-5/1		-	-			38.44	-	-	22.50	23.38	13.12	-	-	13.25	15.31	5.51	252	-	-	382	592	-	-	634	844
92SV-5		-	-			38.44	-	-	22.50	23.38	13.12	-	-	13.25	15.31	5.51	252	-	-	382	592	-	-	634	844
92SV-6/2	50	-	-	324TSC	326TSC	41.94	-	-	22.50	27.22	13.12	-	-	13.25	19.00	5.51	266	-	-	500	762	-	-	766	1028
92SV-6/1		-	-			41.94	-	-	22.50	27.22	13.12	-	-	13.25	19.00	5.51	266	-	-	500	762	-	-	766	1028
92SV-6		-	-			41.94	-	-	22.50	27.22	13.12	-	-	13.25	19.00	5.51	266	-	-	500	762	-	-	766	1028

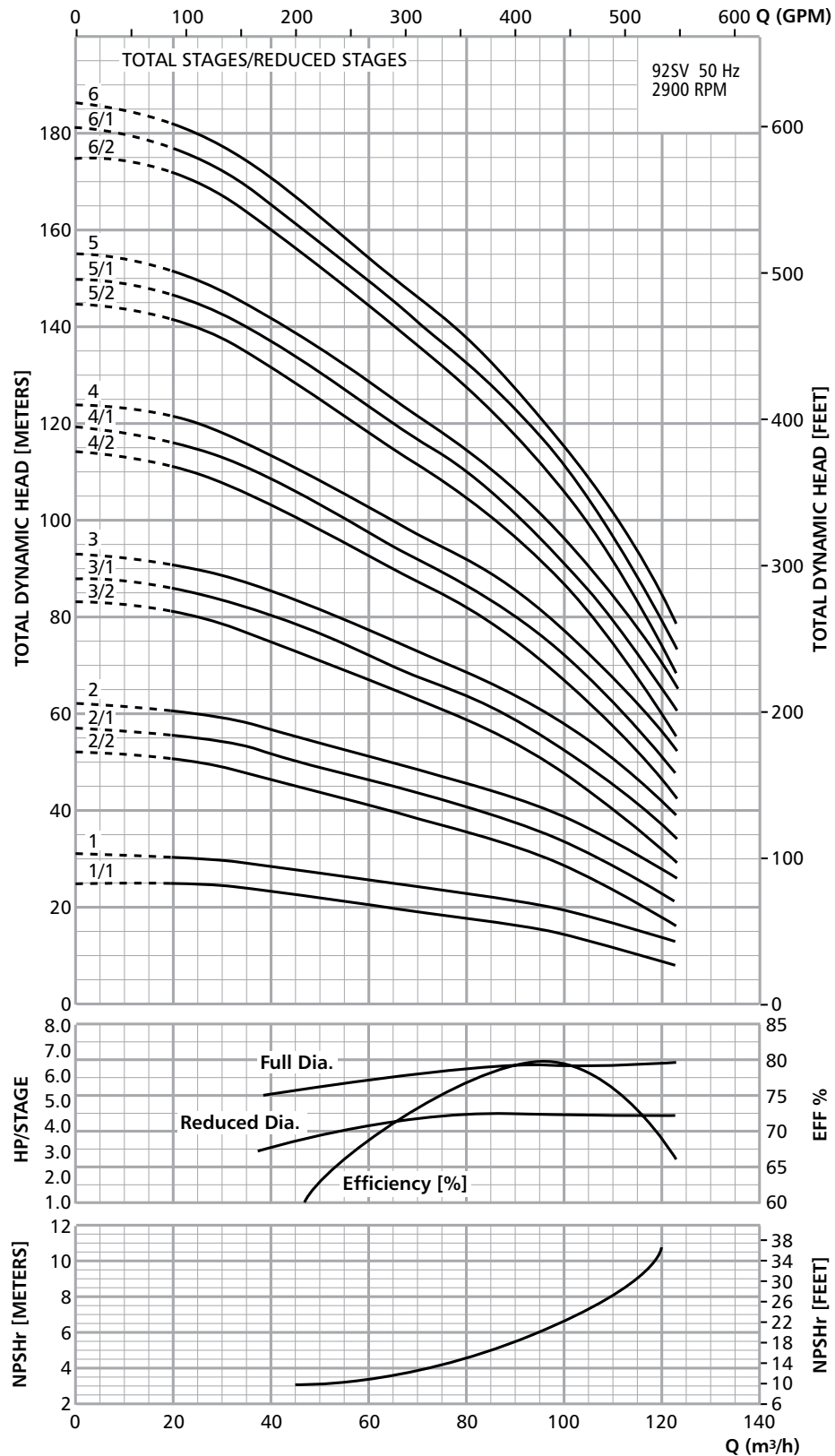

MINIMUM FLOW RATE: 100 GPM [23 m³/hr]

Dimensions and Weights

125SV Series 2900 RPM

50 Hz

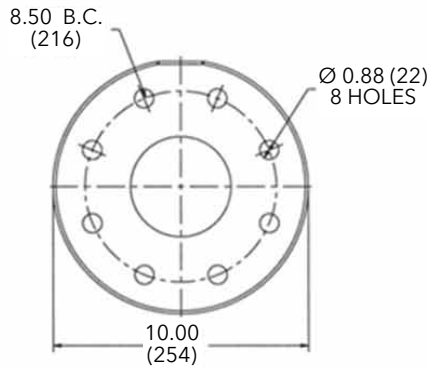
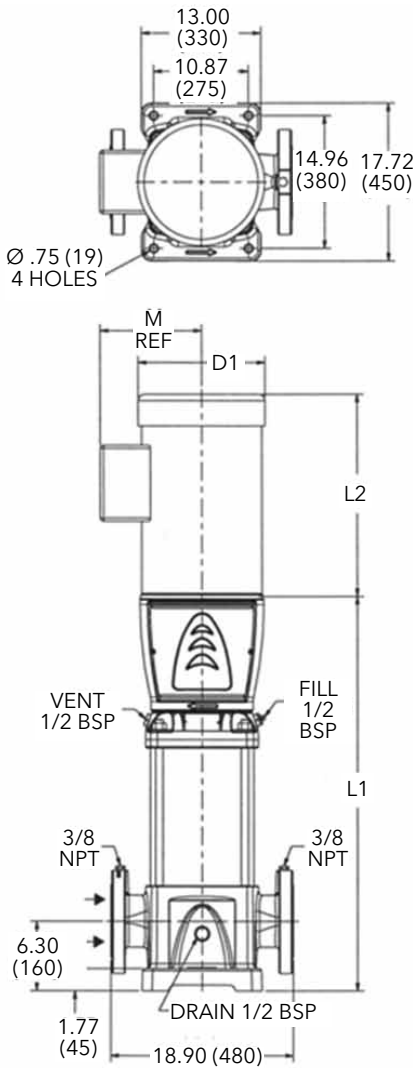

**Cast Iron
5" Class 125 F.F.**

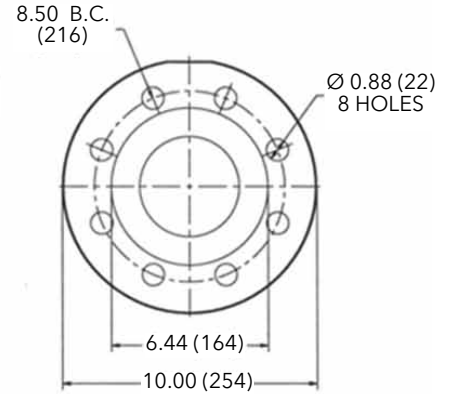

**316SS
5" Class 150 R.F.**

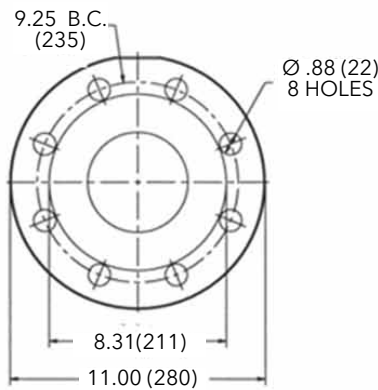

**Cast Iron
5" Class 250 R.F.**

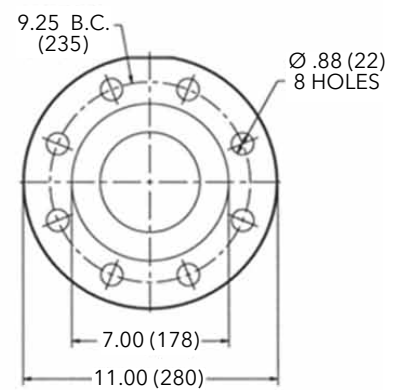

**316SS
5" Class 300 R.F.**

All dimensions are in inches (mm).

Pump Type	Motor				Dimensions (in)														Weight (lbs.)										
	HP	NEMA Frame			L1	L2				L3	L4	L5	L6	M (Ref.)	D1 (max.)				D2	Pump	Motor				Pump/Motor				
		ODP 1Ø	TEFC 1Ø	ODP 3Ø		TEFC 3Ø	ODP 1Ø	TEFC 1Ø	ODP 3Ø						TEFC 3Ø	ODP 1Ø	TEFC 1Ø	ODP 3Ø			TEFC 3Ø	ODP 1Ø	TEFC 1Ø	ODP 3Ø	TEFC 3Ø	ODP 1Ø	TEFC 1Ø	ODP 3Ø	TEFC 3Ø
125SV10C	10	-	-	215TC	254TC	27.30	-	-	15.55	16.57	-	-	-	-	9.22	-	-	10.18	10.28	4.72	256	-	-	125	195	-	-	381	451
125SV22A	20	-	-	254TC	284TC	34.60	-	-	21.44	19.54	-	-	-	12.94	-	-	11.63	12.94	5.51	289	-	-	185	283	-	-	474	572	
125SV32A	25	-	-	284TC	286TC	40.50	-	-	21.75	19.54	-	-	-	12.21	-	-	13.25	12.94	5.51	315	-	-	296	382	-	-	611	697	
125SV44A	30	-	-	286TC	286TC	46.40	-	-	21.75	23.18	-	-	-	13.11	-	-	13.25	15.56	5.51	355	-	-	315	446	-	-	670	801	
125SV50C	40	-	-	324TSC	326TSC	52.30	-	-	22.75	23.19	-	-	-	12.21	-	-	13.03	15.69	5.51	379	-	-	320	450	-	-	699	829	
125SV62B	50	-	-	324TSC	326TSC	58.20	-	-	22.75	30.69	-	-	-	14.95	-	-	13.03	19.25	5.51	412	-	-	372	689	-	-	784	1101	
125SV73B		65.30	-			-	22.75	30.69	-	-	-	14.95	-	-	-	13.03	19.25	5.51	476	-	-	372	689	-	-	848	1165		
125SV81B	60	-	-	364TSC	365TSC	71.10	-	-	24.38	30.69	-	-	-	14.95	-	-	15.13	19.25	5.51	494	-	-	447	747	-	-	941	1241	

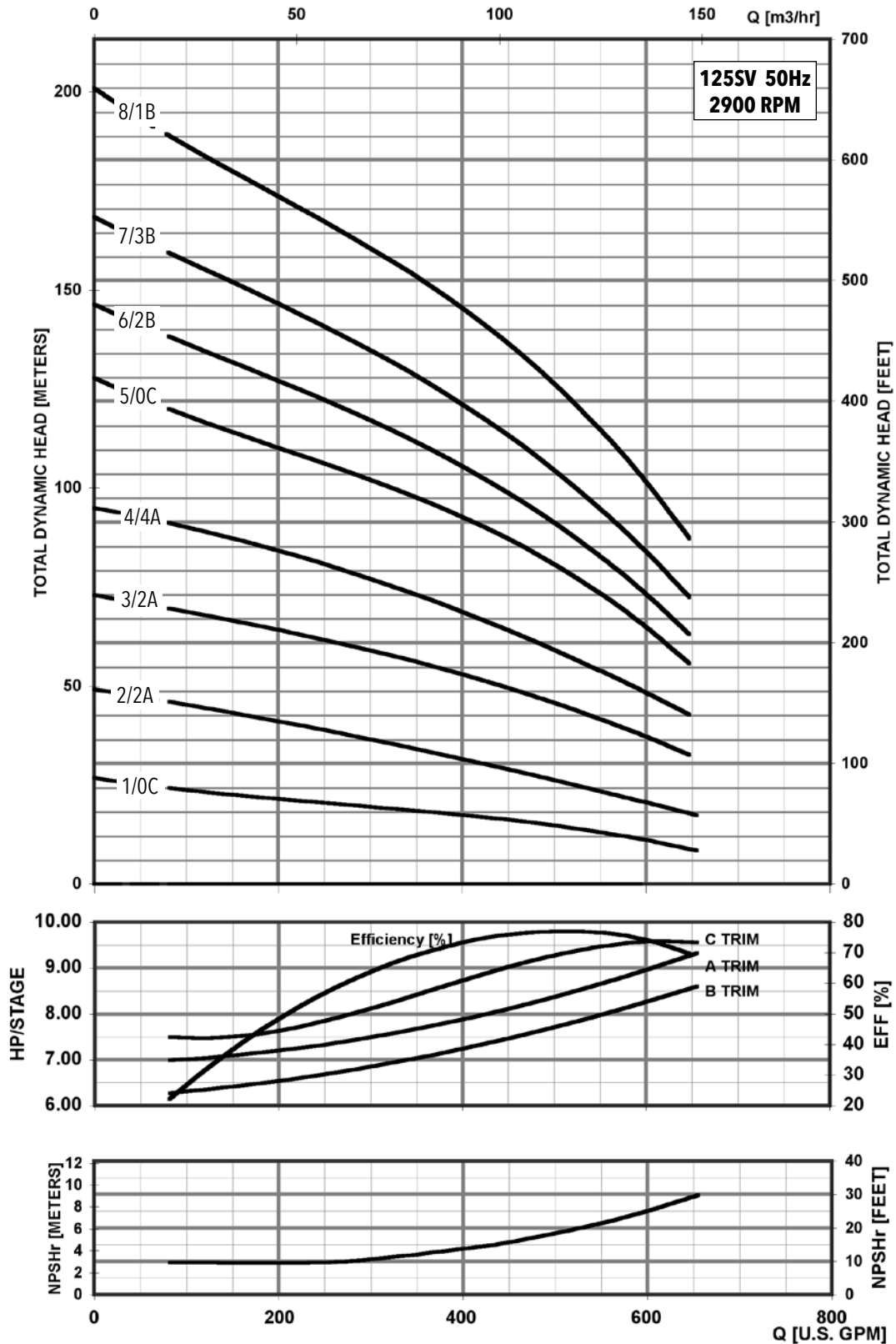

MINIMUM FLOW RATE: 19 m³/hr [82 GPM]

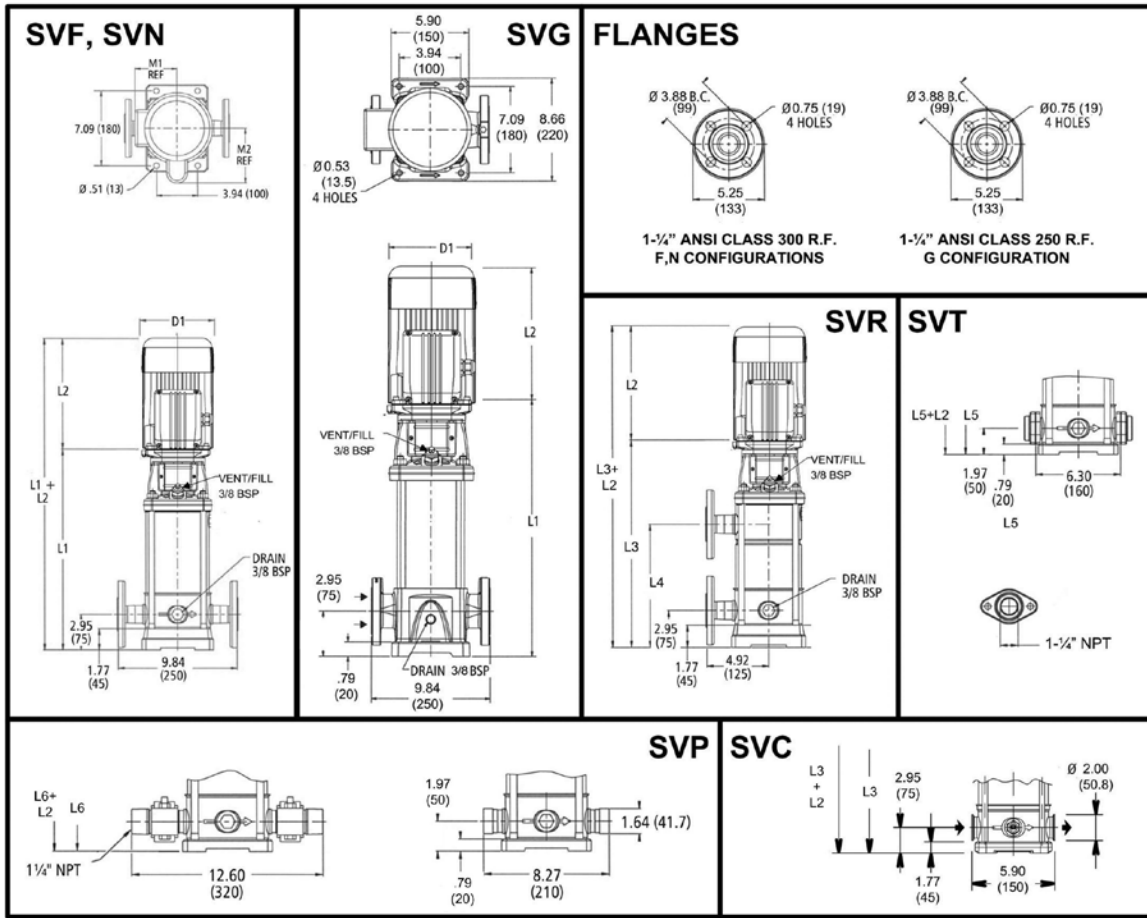

All dimensions are in inches (mm).

Pump Type Stages	Motor				Dimensions (in)											Weight (lbs.)												
	HP	NEMA Frame			L1	L2				L3	L4	L5	L6	M (Ref.)	D1 (max.)				D2	Pump	Motor				Pump/Motor			
		ODP 10	TEFC 10	ODP 30		TEFC 30	ODP 10	TEFC 10	ODP 30						TEFC 30	ODP 10	TEFC 10	ODP 30			TEFC 30	ODP 10	TEFC 10	ODP 30	TEFC 30	ODP 10	TEFC 10	ODP 30
1SV-02	0.5	56C	13.27	10.79	9.91	9.16	9.29	-	-	12.29	12.29	5.19	6.19	6.19	6.19	6.19	4.13	25	27	29	21	21	52	54	46	46		
1SV-03			13.27	10.79	9.91	9.16	9.29	-	-	12.29	12.29	5.19	6.19	6.19	6.19	6.19	4.13	26	27	29	21	21	53	55	47	47		
1SV-04			14.06	10.79	9.91	9.16	9.29	-	-	13.07	13.07	5.19	6.19	6.19	6.19	6.19	4.13	27	27	29	21	21	54	56	48	48		
1SV-05			14.85	10.79	9.91	9.16	9.29	-	-	13.86	13.86	5.19	6.19	6.19	6.19	6.19	4.13	28	27	29	21	21	55	57	49	49		
1SV-06			15.63	10.79	9.91	9.16	9.29	-	-	14.65	14.65	5.19	6.19	6.19	6.19	6.19	4.13	28	27	29	21	21	55	57	49	49		
1SV-07			16.42	10.79	9.91	9.16	9.29	-	-	15.44	15.44	5.19	6.19	6.19	6.19	6.19	4.13	29	27	29	21	21	56	58	50	50		
1SV-08			17.21	10.79	9.91	9.16	9.29	17.21	8.94	16.22	16.22	5.19	6.19	6.19	6.19	6.19	4.13	30	27	29	21	21	57	59	51	51		
1SV-09			18.00	10.79	9.91	9.16	9.29	18.00	9.72	17.01	17.01	5.19	6.19	6.19	6.19	6.19	4.13	31	27	29	21	21	58	60	52	52		
1SV-10			18.78	10.79	9.91	9.16	9.29	18.78	10.51	17.80	17.80	5.19	6.19	6.19	6.19	6.19	4.13	32	27	29	21	21	59	61	53	53		
1SV-11			19.57	10.79	9.91	9.16	9.29	19.57	11.30	18.59	18.59	5.19	6.19	6.19	6.19	6.19	4.13	33	27	29	21	21	60	62	54	54		
1SV-12			20.36	10.79	9.91	9.16	9.29	20.36	12.09	19.37	19.37	5.19	6.19	6.19	6.19	6.19	4.13	34	27	29	21	21	61	63	55	55		
1SV-13			21.14	10.79	9.91	9.16	9.29	21.14	12.87	20.16	20.16	5.19	6.19	6.19	6.19	6.19	4.13	35	27	29	21	21	62	64	56	56		
1SV-14			21.93	10.79	9.91	9.16	9.29	21.93	13.66	20.95	20.95	5.19	6.19	6.19	6.19	6.19	4.13	36	27	29	21	21	63	65	57	57		
1SV-15			22.72	10.79	9.91	9.16	9.29	22.72	14.45	21.74	21.74	5.19	6.19	6.19	6.19	6.19	4.13	37	27	29	21	21	64	66	58	58		
1SV-16			23.51	10.79	9.91	9.16	9.29	23.51	15.24	22.52	22.52	5.19	6.19	6.19	6.19	6.19	4.13	38	27	29	21	21	65	67	59	59		
1SV-17			24.29	10.79	9.91	9.16	9.29	24.29	16.02	23.31	23.31	5.19	6.19	6.19	6.19	6.19	4.13	38	27	29	21	21	65	67	59	59		
1SV-18			25.08	10.79	9.91	9.16	9.29	25.08	16.81	24.10	24.10	5.19	6.19	6.19	6.19	6.19	4.13	39	27	29	21	21	66	68	60	60		
1SV-19			25.87	10.79	9.91	9.16	9.29	25.87	17.60	24.89	24.89	5.19	6.19	6.19	6.19	6.19	4.13	40	27	29	21	21	67	69	61	61		
1SV-20			26.66	10.79	9.91	9.16	9.29	26.66	18.39	25.67	25.67	5.19	6.19	6.19	6.19	6.19	4.13	41	27	29	21	21	68	70	62	62		
1SV-21			27.44	10.79	9.91	9.16	9.29	27.44	19.17	26.46	26.46	5.19	6.19	6.19	6.19	6.19	4.13	42	27	29	21	21	69	71	63	63		
1SV-22			28.23	10.79	9.91	9.16	9.29	28.23	19.96	27.25	27.25	5.19	6.19	6.19	6.19	6.19	4.13	43	27	29	21	21	70	72	64	64		
1SV-23			29.02	10.79	9.91	9.16	9.29	29.02	20.75	28.03	28.03	5.19	6.19	6.19	6.19	6.19	4.13	45	27	29	21	21	72	74	66	66		
1SV-24			29.81	10.79	9.91	9.16	9.29	29.81	21.54	28.82	28.82	5.19	6.19	6.19	6.19	6.19	4.13	46	27	29	21	21	73	75	67	67		
1SV-25			30.59	10.79	9.91	9.16	9.29	30.59	22.32	29.61	29.61	5.19	6.19	6.19	6.19	6.19	4.13	47	27	29	21	21	74	76	68	68		
1SV-26			31.38	10.79	9.91	9.16	9.29	31.38	23.11	30.40	30.40	5.19	6.19	6.19	6.19	6.19	4.13	47	27	29	21	21	74	76	68	68		
1SV-27			32.17	10.79	9.91	9.16	9.29	32.17	23.90	31.18	31.18	5.19	6.19	6.19	6.19	6.19	4.13	48	27	29	21	21	75	77	69	69		
1SV-28			32.96	10.79	9.91	9.16	9.29	32.96	24.68	31.97	31.97	5.19	6.19	6.19	6.19	6.19	4.13	49	27	29	21	21	76	78	70	70		
1SV-29			34.14	10.79	9.91	9.16	9.29	34.14	25.47	33.15	33.15	5.19	6.19	6.19	6.19	6.19	4.13	50	27	29	21	21	77	79	71	71		
1SV-30			34.53	10.79	9.91	9.16	9.29	34.53	26.26	33.55	33.55	5.19	6.19	6.19	6.19	6.19	4.13	51	27	29	21	21	78	80	72	72		

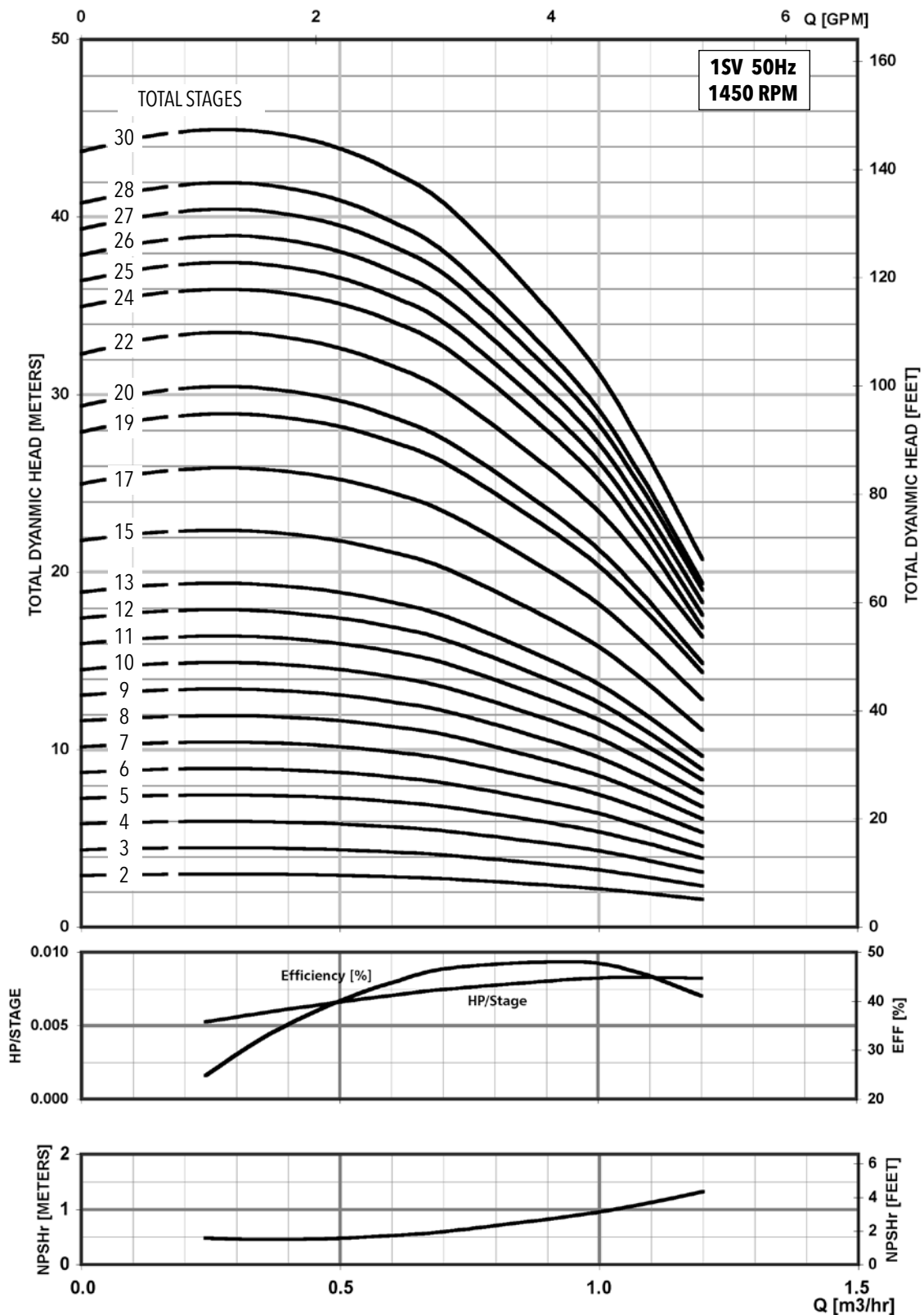

MINIMUM FLOW RATE: .2 m³/hr [1 GPM]

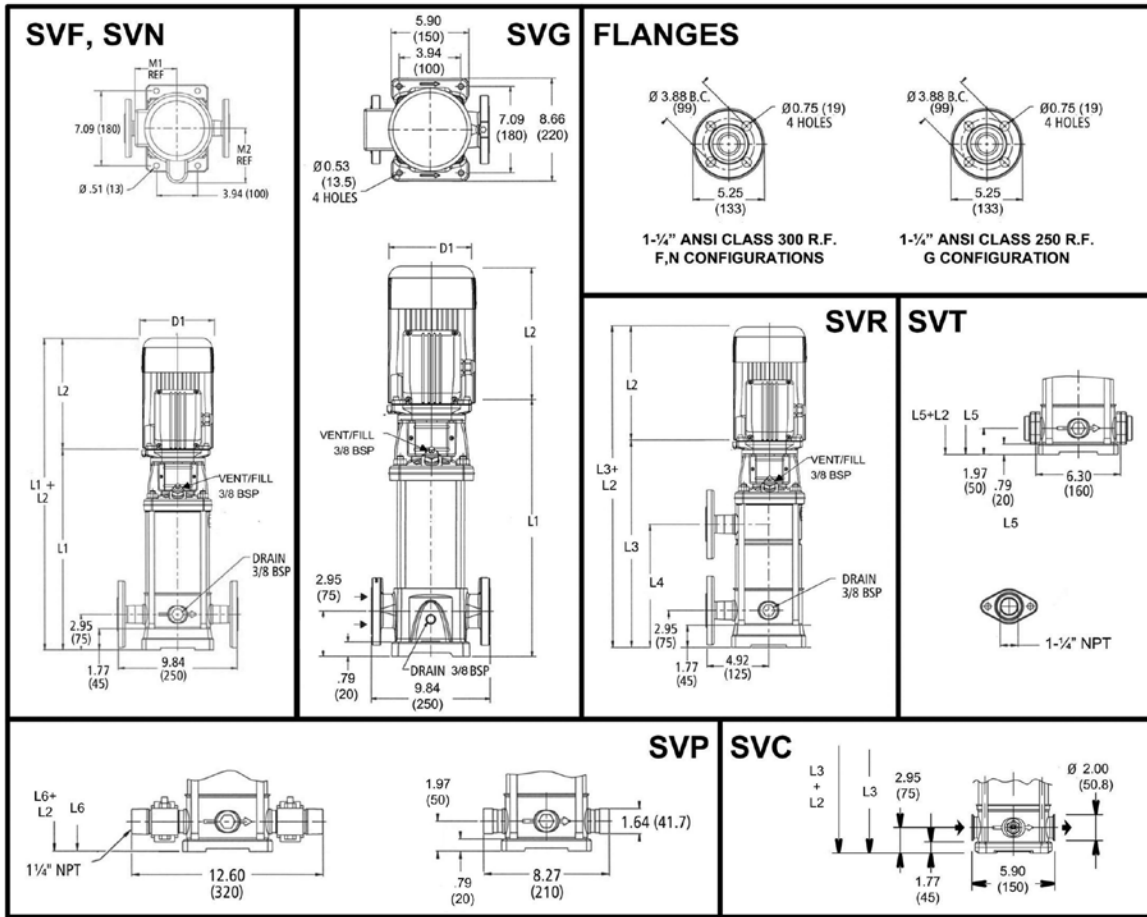

All dimensions are in inches (mm).

Pump Type Stages	Motor				Dimensions (in)												Weight (lbs.)											
	NEMA Frame				L2				D1 (max.)				D2				Motor				Pump/Motor							
	HP	ODP 1Ø	TEFC 1Ø	ODP 3Ø	TEFC 3Ø	L1	ODP 1Ø	TEFC 1Ø	ODP 3Ø	TEFC 3Ø	L3	L4	L5	L6	M (Ref.)	ODP 1Ø	TEFC 1Ø	ODP 3Ø	TEFC 3Ø	D2	Pump	ODP 1Ø	TEFC 1Ø	ODP 3Ø	TEFC 3Ø	ODP 1Ø	TEFC 1Ø	ODP 3Ø
3SV-02					13.27	10.79	9.91	9.16	9.29	-	-	12.29	12.29	5.19	6.19	6.19	6.19	6.19	4.13	24	27	29	21	21	51	53	45	45
3SV-03					13.27	10.79	9.91	9.16	9.29	-	-	12.29	12.29	5.19	6.19	6.19	6.19	6.19	4.13	25	27	29	21	21	52	54	46	46
3SV-04					14.06	10.79	9.91	9.16	9.29	-	-	13.07	13.07	5.19	6.19	6.19	6.19	6.19	4.13	26	27	29	21	21	53	55	47	47
3SV-05					14.85	10.79	9.91	9.16	9.29	-	-	13.86	13.86	5.19	6.19	6.19	6.19	6.19	4.13	27	27	29	21	21	54	56	48	48
3SV-06					15.63	10.79	9.91	9.16	9.29	-	-	14.65	14.65	5.19	6.19	6.19	6.19	6.19	4.13	28	27	29	21	21	55	57	49	49
3SV-07					16.42	10.79	9.91	9.16	9.29	-	-	15.44	15.44	5.19	6.19	6.19	6.19	6.19	4.13	30	27	29	21	21	57	59	51	51
3SV-08					17.21	10.79	9.91	9.16	9.29	17.21	8.94	16.22	16.22	5.19	6.19	6.19	6.19	6.19	4.13	31	27	29	21	21	58	60	52	52
3SV-09					18.00	10.79	9.91	9.16	9.29	18.00	9.72	17.01	17.01	5.19	6.19	6.19	6.19	6.19	4.13	32	27	29	21	21	59	61	53	53
3SV-10					18.78	10.79	9.91	9.16	9.29	18.78	10.51	17.80	17.80	5.19	6.19	6.19	6.19	6.19	4.13	33	27	29	21	21	60	62	54	54
3SV-11					19.57	10.79	9.91	9.16	9.29	19.57	11.30	18.59	18.59	5.19	6.19	6.19	6.19	6.19	4.13	34	27	29	21	21	61	63	55	55
3SV-12					20.36	10.79	9.91	9.16	9.29	20.36	12.09	19.37	19.37	5.19	6.19	6.19	6.19	6.19	4.13	35	27	29	21	21	62	64	56	56
3SV-13					21.14	10.79	9.91	9.16	9.29	21.14	12.87	20.16	20.16	5.19	6.19	6.19	6.19	6.19	4.13	36	27	29	21	21	63	65	57	57
3SV-14					21.93	10.79	9.91	9.16	9.29	21.93	13.66	20.95	20.95	5.19	6.19	6.19	6.19	6.19	4.13	37	27	29	21	21	64	66	58	58
3SV-15					22.72	10.79	9.91	9.16	9.29	22.72	14.45	21.74	21.74	5.19	6.19	6.19	6.19	6.19	4.13	38	27	29	21	21	65	67	59	59
3SV-16	0.5		56C		23.51	10.79	9.91	9.16	9.29	23.51	15.24	22.52	22.52	5.19	6.19	6.19	6.19	6.19	4.13	39	27	29	21	21	66	68	60	60
3SV-17					24.29	10.79	9.91	9.16	9.29	24.29	16.02	23.31	23.31	5.19	6.19	6.19	6.19	6.19	4.13	40	27	29	21	21	67	69	61	61
3SV-18					25.08	10.79	9.91	9.16	9.29	25.08	16.81	24.10	24.10	5.19	6.19	6.19	6.19	6.19	4.13	41	27	29	21	21	68	70	62	62
3SV-19					25.87	10.79	9.91	9.16	9.29	25.87	17.60	24.89	24.89	5.19	6.19	6.19	6.19	6.19	4.13	41	27	29	21	21	68	70	62	62
3SV-20					26.66	10.79	9.91	9.16	9.29	26.66	18.39	25.67	25.67	5.19	6.19	6.19	6.19	6.19	4.13	42	27	29	21	21	69	71	63	63
3SV-21					27.44	10.79	9.91	9.16	9.29	27.44	19.17	26.46	26.46	5.19	6.19	6.19	6.19	6.19	4.13	43	27	29	21	21	70	72	64	64
3SV-22					28.23	10.79	9.91	9.16	9.29	28.23	19.96	27.25	27.25	5.19	6.19	6.19	6.19	6.19	4.13	44	27	29	21	21	71	73	65	65
3SV-23					29.02	10.79	9.91	9.16	9.29	29.02	20.75	28.03	28.03	5.19	6.19	6.19	6.19	6.19	4.13	45	27	29	21	21	72	74	66	66
3SV-24					29.81	10.79	9.91	9.16	9.29	29.81	21.54	28.82	28.82	5.19	6.19	6.19	6.19	6.19	4.13	46	27	29	21	21	73	75	67	67
3SV-25					30.59	10.79	9.91	9.16	9.29	30.59	22.32	29.61	29.61	5.19	6.19	6.19	6.19	6.19	4.13	47	27	29	21	21	74	76	68	68
3SV-26					31.38	10.79	9.91	9.16	9.29	31.38	23.11	30.40	30.40	5.19	6.19	6.19	6.19	6.19	4.13	48	27	29	21	21	75	77	69	69
3SV-27					31.77	10.79	9.91	9.16	9.29	31.77	23.90	30.79	30.79	5.19	6.19	6.19	6.19	6.19	4.13	50	27	29	21	21	77	79	71	71
3SV-28					32.56	10.79	9.91	9.16	9.29	32.56	24.68	31.58	31.58	5.19	6.19	6.19	6.19	6.19	4.13	51	27	29	21	21	78	80	72	72
3SV-29					33.74	10.79	9.91	9.16	9.29	33.74	25.47	32.76	32.76	5.19	6.19	6.19	6.19	6.19	4.13	52	27	29	21	21	79	81	73	73
3SV-30					34.53	10.79	9.91	9.16	9.29	34.53	26.26	33.55	33.55	5.19	6.19	6.19	6.19	6.19	4.13	53	27	29	21	21	80	82	74	74

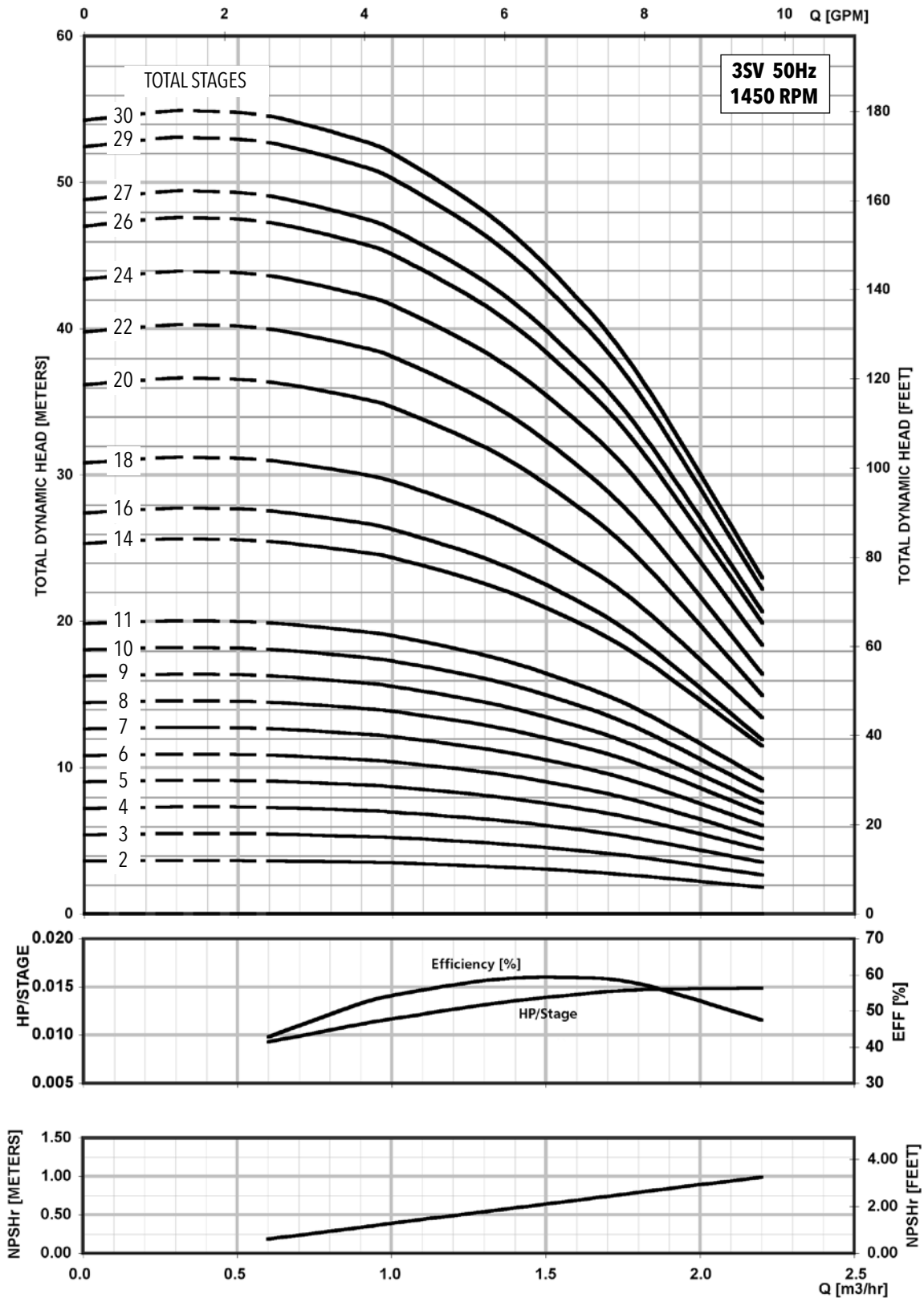

MINIMUM FLOW RATE: 1 GPM [.24 m³/hr]

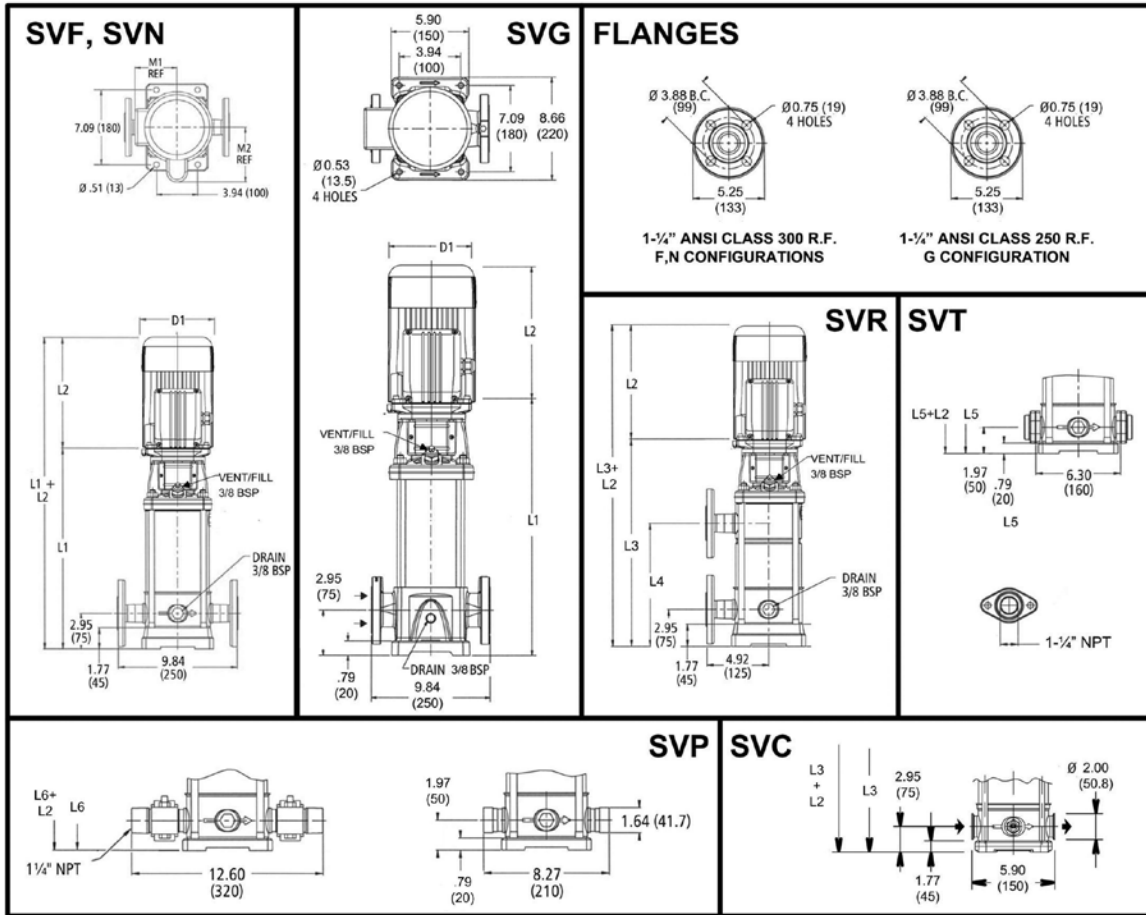

All dimensions are in inches (mm).

Pump Type Stages	Motor				Dimensions (in)											Weight (lbs.)												
	NEMA Frame				L2				D1 (max.)				Motor				Pump/Motor											
	HP	ODP 10	TEFC 10	ODP 30	TEFC 30	L1	ODP 10	TEFC 10	ODP 30	TEFC 30	L3	L4	L5	L6	M (Ref.)	ODP 10	TEFC 10	ODP 30	TEFC 30	D2	Pump	ODP 10	TEFC 10	ODP 30	TEFC 30	ODP 10	TEFC 10	ODP 30
5SV-02					13.86	10.79	9.91	9.16	9.29	-	-	12.88	12.88	5.19	6.19	6.19	6.19	6.19	4.13	25	27	29	21	21	52	54	46	46
5SV-03					13.86	10.79	9.91	9.16	9.29	-	-	12.88	12.88	5.19	6.19	6.19	6.19	6.19	4.13	26	27	29	21	21	53	55	47	47
5SV-04					14.85	10.79	9.91	9.16	9.29	-	-	13.86	13.86	5.19	6.19	6.19	6.19	6.19	4.13	28	27	29	21	21	55	57	49	49
5SV-05					15.83	10.79	9.91	9.16	9.29	-	-	14.85	14.85	5.19	6.19	6.19	6.19	6.19	4.13	29	27	29	21	21	56	58	50	50
5SV-06					16.81	10.79	9.91	9.16	9.29	-	-	15.83	15.83	5.19	6.19	6.19	6.19	6.19	4.13	30	27	29	21	21	57	59	51	51
5SV-07					17.80	10.79	9.91	9.16	9.29	17.80	9.53	16.81	16.81	5.19	6.19	6.19	6.19	6.19	4.13	31	27	29	21	21	58	60	52	52
5SV-08					18.78	10.79	9.91	9.16	9.29	18.78	10.51	17.80	17.80	5.19	6.19	6.19	6.19	6.19	4.13	33	27	29	21	21	60	62	54	54
5SV-09					19.77	10.79	9.91	9.16	9.29	19.77	11.50	18.78	18.78	5.19	6.19	6.19	6.19	6.19	4.13	33	27	29	21	21	60	62	54	54
5SV-10					20.75	10.79	9.91	9.16	9.29	20.75	12.48	19.77	19.77	5.19	6.19	6.19	6.19	6.19	4.13	34	27	29	21	21	61	63	55	55
5SV-11					21.74	10.79	9.91	9.16	9.29	21.74	13.46	20.75	20.75	5.19	6.19	6.19	6.19	6.19	4.13	35	27	29	21	21	62	64	56	56
5SV-12					22.72	10.79	9.91	9.16	9.29	22.72	14.45	21.74	21.74	5.19	6.19	6.19	6.19	6.19	4.13	36	27	29	21	21	63	65	57	57
5SV-13					23.70	10.79	9.91	9.16	9.29	23.70	15.43	22.72	22.72	5.19	6.19	6.19	6.19	6.19	4.13	38	27	29	21	21	65	67	59	59
5SV-14					24.69	10.79	9.91	9.16	9.29	24.69	16.42	23.70	23.70	5.19	6.19	6.19	6.19	6.19	4.13	38	27	29	21	21	65	67	59	59
5SV-15					25.67	10.79	9.91	9.16	9.29	25.67	17.40	24.69	24.69	5.19	6.19	6.19	6.19	6.19	4.13	39	27	29	21	21	66	68	60	60
5SV-16					26.66	10.79	9.91	9.16	9.29	26.66	18.39	25.67	25.67	5.19	6.19	6.19	6.19	6.19	4.13	41	27	29	21	21	68	70	62	62
5SV-17					27.84	10.79	9.91	9.16	9.29	27.84	19.37	26.85	26.85	5.19	6.19	6.19	6.19	6.19	4.13	43	27	29	21	21	70	72	64	64
5SV-18					28.63	10.79	9.91	9.16	9.29	28.63	20.35	27.64	27.64	5.19	6.19	6.19	6.19	6.19	4.13	44	27	29	21	21	71	73	65	65
5SV-19					29.81	10.79	9.91	9.16	9.29	29.81	21.34	28.82	28.82	5.19	6.19	6.19	6.19	6.19	4.13	45	27	29	21	21	72	74	66	66
5SV-20					30.99	10.79	9.91	9.16	9.29	30.99	22.32	30.00	30.00	5.19	6.19	6.19	6.19	6.19	4.13	46	27	29	21	21	73	75	67	67
5SV-21					31.58	10.79	9.91	9.16	9.29	31.58	23.31	30.59	30.59	5.19	6.19	6.19	6.19	6.19	4.13	47	27	29	21	21	74	76	68	68
5SV-22					32.64	10.79	9.91	9.16	9.29	32.64	24.29	31.66	31.66	5.19	6.19	6.19	6.19	6.19	4.13	48	27	29	21	21	75	77	69	69
5SV-23					33.55	10.79	9.91	9.16	9.29	33.55	25.28	32.56	32.56	5.19	6.19	6.19	6.19	6.19	4.13	49	27	29	21	21	76	78	70	70
5SV-24					34.61	10.79	9.91	9.16	9.29	34.61	26.26	33.63	33.63	5.19	6.19	6.19	6.19	6.19	4.13	51	27	29	21	21	78	80	72	72
5SV-25					35.51	10.79	9.91	9.16	9.29	35.51	27.24	34.53	34.53	5.19	6.19	6.19	6.19	6.19	4.13	51	27	29	21	21	78	80	72	72
5SV-26					36.58	10.79	9.91	9.16	9.29	36.58	28.23	35.59	35.59	5.19	6.19	6.19	6.19	6.19	4.13	52	27	29	21	21	79	81	73	73
5SV-27					37.56	10.79	9.91	9.16	9.29	37.56	29.21	36.58	36.58	5.19	6.19	6.19	6.19	6.19	4.13	53	27	29	21	21	80	82	74	74

Performance Curve

5SV 1450 RPM

50 Hz

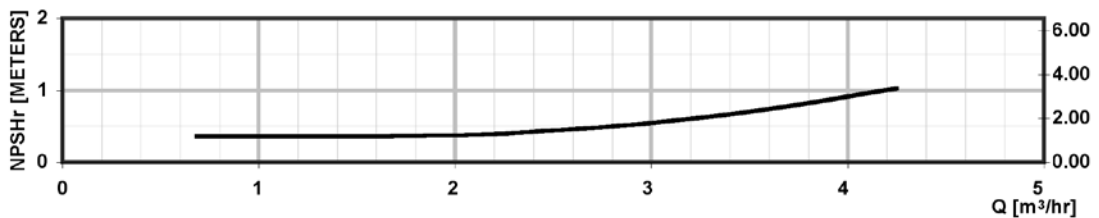
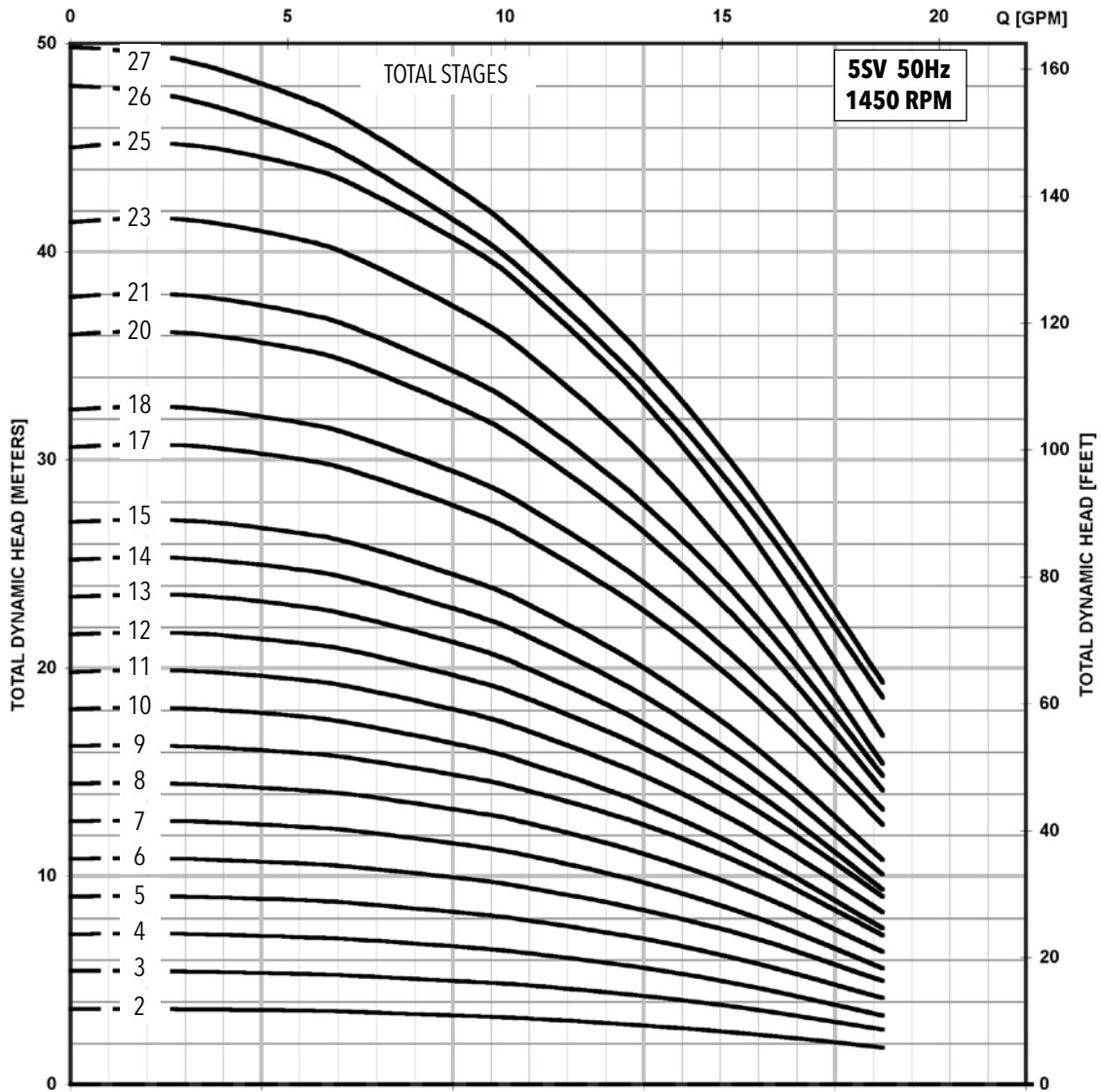

MINIMUM FLOW RATE: .7 m³/hr [3 GPM]

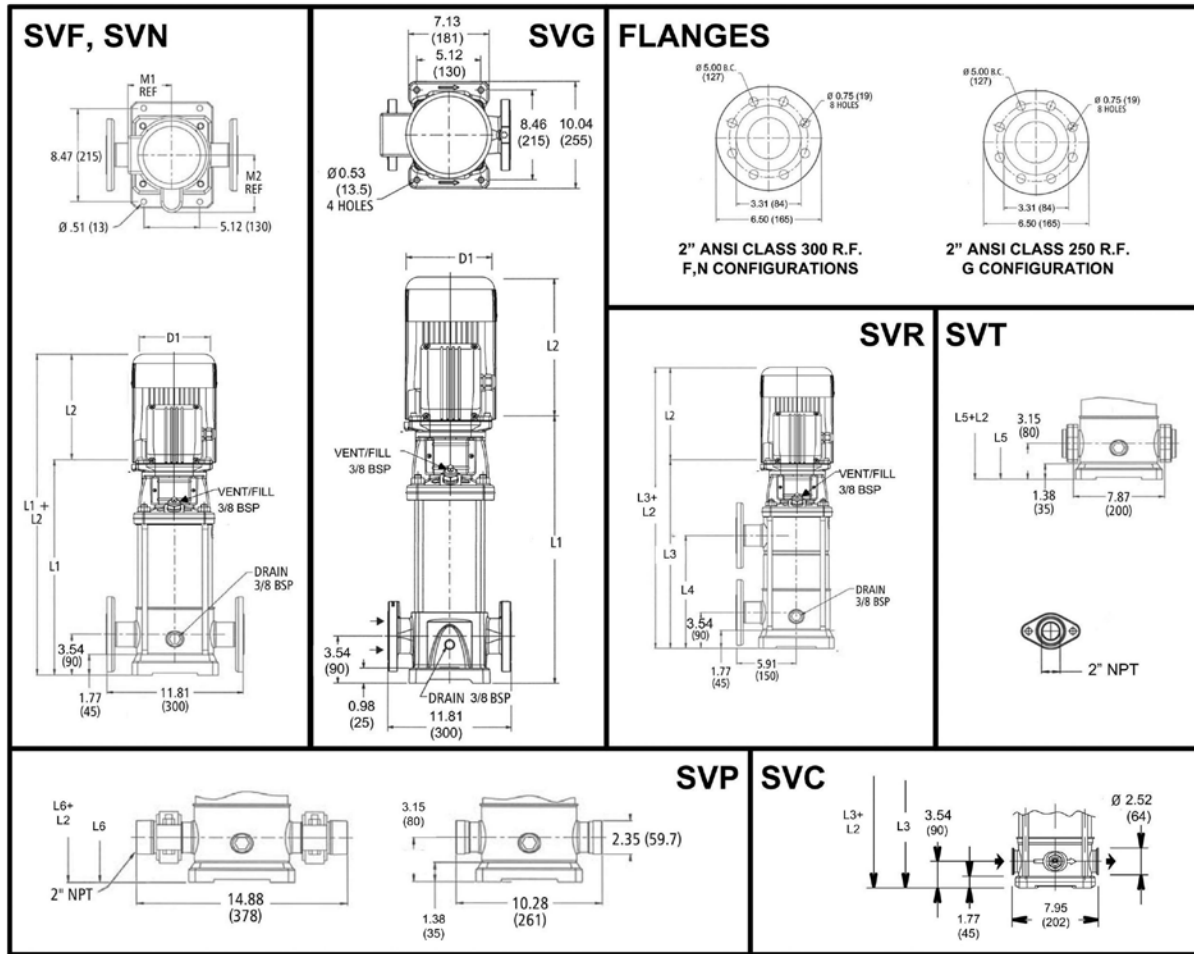

All dimensions are in inches (mm).

Pump Type Stages	Motor				Dimensions (in)											Weight (lbs.)													
	HP	NEMA Frame				L1	L2				L3	L4	L5	L6	M (Ref.)	D1 (max.)				D2	Pump	Motor				Pump/Motor			
		ODP 1Ø	TEFC 1Ø	ODP 3Ø	TEFC 3Ø		ODP 1Ø	TEFC 1Ø	ODP 3Ø	TEFC 3Ø						ODP 1Ø	TEFC 1Ø	ODP 3Ø	TEFC 3Ø			ODP 1Ø	TEFC 1Ø	ODP 3Ø	TEFC 3Ø	ODP 1Ø	TEFC 1Ø	ODP 3Ø	TEFC 3Ø
10SV-01	0.5	56C	16.56	10.79	9.91	9.16	9.29	-	-	16.17	16.17	5.19	6.19	6.19	6.19	6.19	6.19	4.13	36	27	29	21	21	63	65	57	57		
10SV-02			16.56	10.79	9.91	9.16	9.29	-	-	16.17	16.17	5.19	6.19	6.19	6.19	6.19	6.19	4.13	38	27	29	21	21	65	67	59	59		
10SV-03			17.82	10.79	9.91	9.16	9.29	-	-	17.43	17.43	5.19	6.19	6.19	6.19	6.19	6.19	4.13	40	27	29	21	21	67	69	61	61		
10SV-04			19.08	10.79	9.91	9.16	9.29	-	-	18.69	18.69	5.19	6.19	6.19	6.19	6.19	6.19	4.13	43	27	29	21	21	70	72	64	64		
10SV-05			20.34	10.79	9.91	9.16	9.29	20.34	10.20	19.95	19.95	5.19	6.19	6.19	6.19	6.19	6.19	4.13	45	27	29	21	21	72	74	66	66		
10SV-06			21.60	10.79	9.91	9.16	9.29	21.60	11.46	21.21	21.21	5.19	6.19	6.19	6.19	6.19	6.19	4.13	47	27	29	21	21	74	76	68	68		
10SV-07			22.86	10.79	9.91	9.16	9.29	22.86	12.72	22.47	22.47	5.19	6.19	6.19	6.19	6.19	6.19	4.13	49	27	29	21	21	76	78	70	70		
10SV-08			24.12	10.79	9.91	9.16	9.29	24.12	13.98	23.72	23.72	5.19	6.19	6.19	6.19	6.19	6.19	4.13	51	27	29	21	21	78	80	72	72		
10SV-09			25.38	10.79	9.91	9.16	9.29	25.38	15.24	24.98	24.98	5.19	6.19	6.19	6.19	6.19	6.19	4.13	53	27	29	21	21	80	82	74	74		
10SV-10			26.64	10.79	9.91	9.16	9.29	26.64	16.50	26.24	26.24	5.19	6.19	6.19	6.19	6.19	6.19	4.13	56	27	29	21	21	83	85	77	77		
10SV-11			27.90	10.66	11.19	9.16	9.29	27.90	17.76	27.50	27.50	5.74	6.2	7.19	6.19	6.19	6.19	4.13	58	32	40	23	23	90	98	81	81		
10SV-12			28.37	10.66	11.19	9.16	9.29	28.37	19.02	27.98	27.98	5.74	6.2	7.19	6.19	6.19	6.19	4.13	60	32	40	23	23	92	100	83	83		
10SV-13			30.44	10.66	11.19	9.16	9.29	30.44	20.28	30.04	30.04	5.74	6.2	7.19	6.19	6.19	6.19	4.13	65	32	40	23	23	97	105	88	88		
10SV-14			31.78	10.66	11.19	9.16	9.29	31.78	21.54	31.38	31.38	5.74	6.2	7.19	6.19	6.19	6.19	4.13	67	32	40	23	23	99	107	90	90		
10SV-15	32.96	10.67	11.19	10.66	9.91	32.96	22.80	32.56	32.56	5.74	6.2	7.19	6.2	6.19	4.72	69	32	40	30	28	101	109	99	97					
10SV-16	34.22	10.67	11.19	10.66	9.91	34.22	24.06	33.82	33.82	5.74	6.2	7.19	6.2	6.19	4.72	71	32	40	30	28	103	111	101	99					
10SV-17	35.48	10.67	11.19	10.66	9.91	35.48	25.31	35.08	35.08	5.74	6.2	7.19	6.2	6.19	4.72	73	32	40	30	28	105	113	103	101					
10SV-18	36.74	10.67	11.19	10.66	9.91	36.74	26.57	36.34	36.34	5.74	6.2	7.19	6.2	6.19	4.72	75	32	40	30	28	107	115	105	103					
10SV-19	38.08	10.67	11.19	10.66	9.91	38.08	27.83	37.68	37.68	5.74	6.2	7.19	6.2	6.19	4.72	77	32	40	30	28	109	117	107	105					
10SV-20	39.26	11.18	12.06	11.16	10.79	39.26	29.09	38.86	38.86	5.74	7.19	7.19	6.2	6.19	4.72	79	43	51	32	33	122	130	111	112					

Performance Curve

10SV 1450 RPM

50 Hz

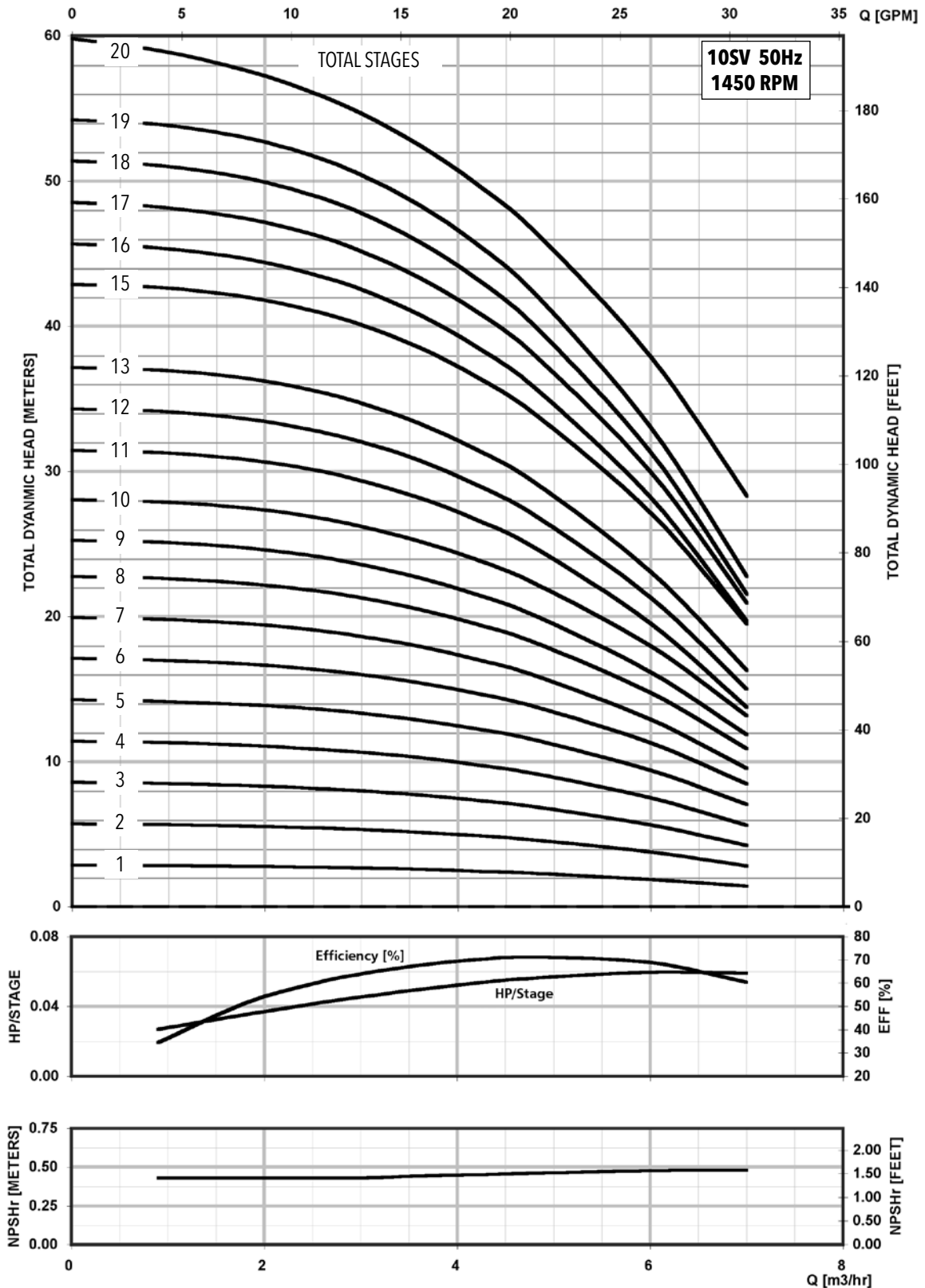

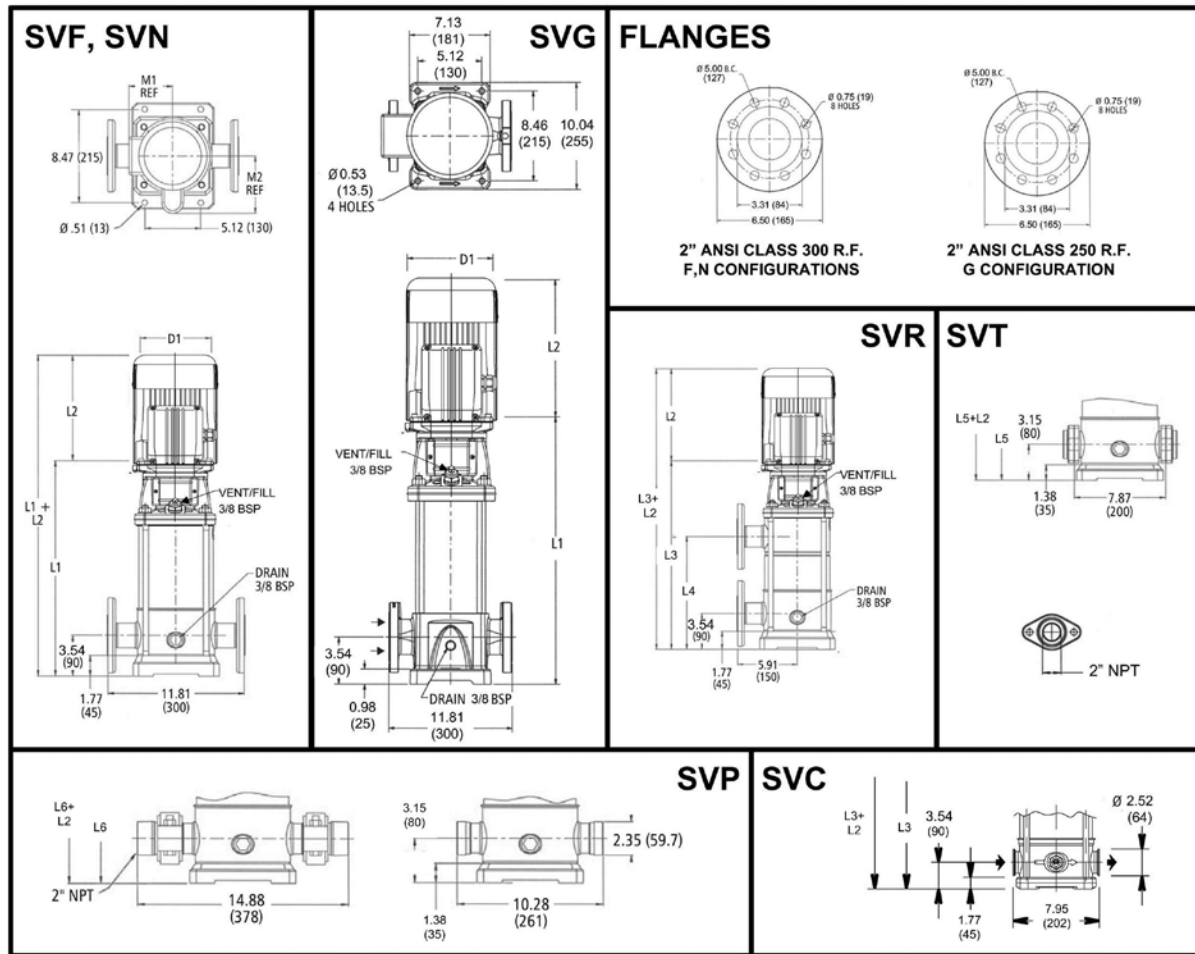

All dimensions are in inches (mm).

Pump Type	HP	Motor					Dimensions (in)										Weight (lbs.)																																			
		NEMA Frame					L1	L2				L3	L4	L5	L6	M (Ref.)	D1 (max.)				D2	Pump	Motor				Pump/Motor																									
		ODP 1Ø	TEFC 1Ø	ODP 3Ø	TEFC 3Ø	ODP 1Ø		TEFC 1Ø	ODP 3Ø	TEFC 3Ø	ODP 1Ø						TEFC 1Ø	ODP 3Ø	TEFC 3Ø	ODP 1Ø			TEFC 1Ø	ODP 3Ø	TEFC 3Ø	ODP 1Ø	TEFC 1Ø	ODP 3Ø	TEFC 3Ø																							
15SV-01	56C	0.5	27.68	10.67	11.19	10.66	9.91	9.16	9.29	-	-	17.82	17.82	5.19	6.19	6.19	6.19	6.19	4.13	37	27	29	21	21	64	66	58	58																								
15SV-02																													18.21	10.79	9.91	9.16	9.29	-	-	17.82	17.82	5.19	6.19	6.19	6.19	6.19	4.13	41	27	29	21	21	68	70	62	62
15SV-03																													20.10	10.79	9.91	9.16	9.29	-	-	19.71	19.71	5.19	6.19	6.19	6.19	6.19	4.13	44	27	29	21	21	71	73	65	65
15SV-04																													21.99	10.79	9.91	9.16	9.29	21.99	11.85	21.60	21.60	5.19	6.19	6.19	6.19	6.19	4.13	47	27	29	21	21	74	76	68	68
15SV-05		23.88	10.66	11.19	9.16	9.29	23.88	13.74	23.49	23.49	5.74	6.19	7.19	6.19	6.19	4.13	49	32	40	23	23	81	89	72	72																											
15SV-06		25.79	10.66	11.19	9.16	9.29	25.79	15.63	25.40	25.40	5.74	6.19	7.19	6.19	6.19	4.13	56	32	40	23	23	88	96	79	79																											
15SV-07		27.68	10.67	11.19	10.66	9.91	27.68	17.52	27.29	27.29	5.74	6.19	7.19	6.19	6.19	4.72	59	32	40	30	28	91	99	89	87																											
15SV-08		29.57	10.67	11.19	10.66	9.91	29.57	19.41	29.18	29.18	5.74	6.19	7.19	6.19	6.19	4.72	61	32	40	30	28	93	101	91	89																											
15SV-09		31.46	11.18	12.06	11.16	10.79	31.46	21.30	31.07	31.07	5.74	7.19	7.19	6.19	6.19	4.72	64	43	51	32	33	107	115	96	97																											
15SV-10		33.35	11.18	12.06	11.16	10.79	33.35	23.19	32.96	32.96	5.74	7.19	7.19	6.19	6.19	4.72	68	43	51	32	33	111	119	100	101																											
15SV-11		35.24	11.18	12.06	11.16	10.79	35.24	25.08	34.85	34.85	5.74	7.19	7.19	6.19	6.19	4.72	71	43	51	32	33	114	122	103	104																											
15SV-12		37.13	11.18	12.06	11.16	10.79	37.13	26.97	36.74	36.74	5.74	7.19	7.19	6.19	6.19	4.72	74	43	51	32	33	117	125	106	107																											
15SV-13		39.02	11.18	12.06	11.16	10.79	39.02	28.86	38.63	38.63	5.74	7.19	7.19	6.19	6.19	4.72	77	43	51	32	33	120	128	109	110																											
15SV-14		2	40.91	11.57	13.44	11.18	11.16	40.91	30.75	40.52	40.52	5.75	6.5	7.19	7.16	7.19	5.51	80	49	64	41	44	129	144	121	124																										
15SV-15			42.80	11.57	13.44	11.18	11.16	42.80	32.64	42.41	42.41	5.75	6.5	7.19	7.16	7.19	5.51	83	49	64	41	44	132	147	124	127																										

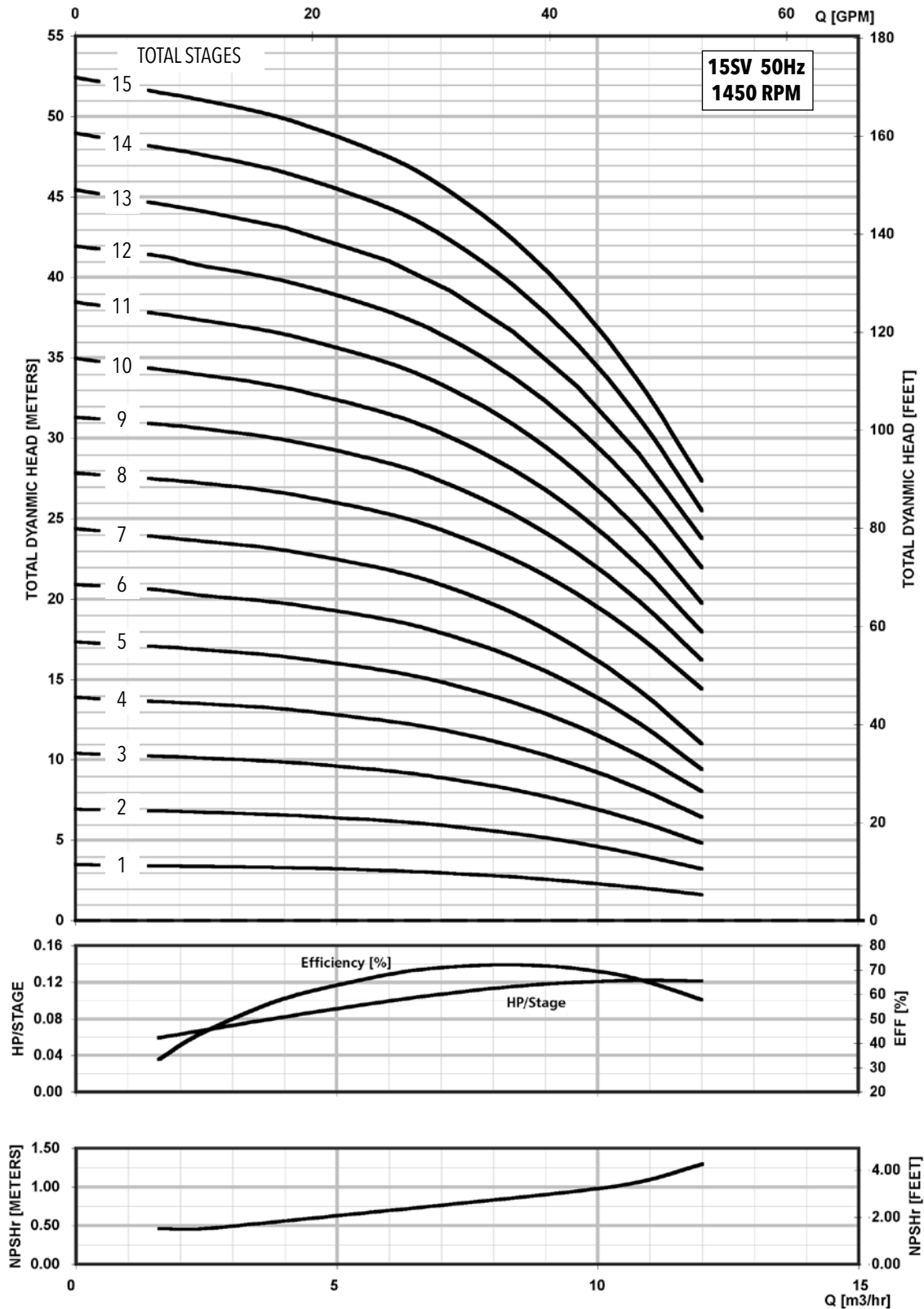

MINIMUM FLOW RATE: 1.6 m³/hr [7 GPM]

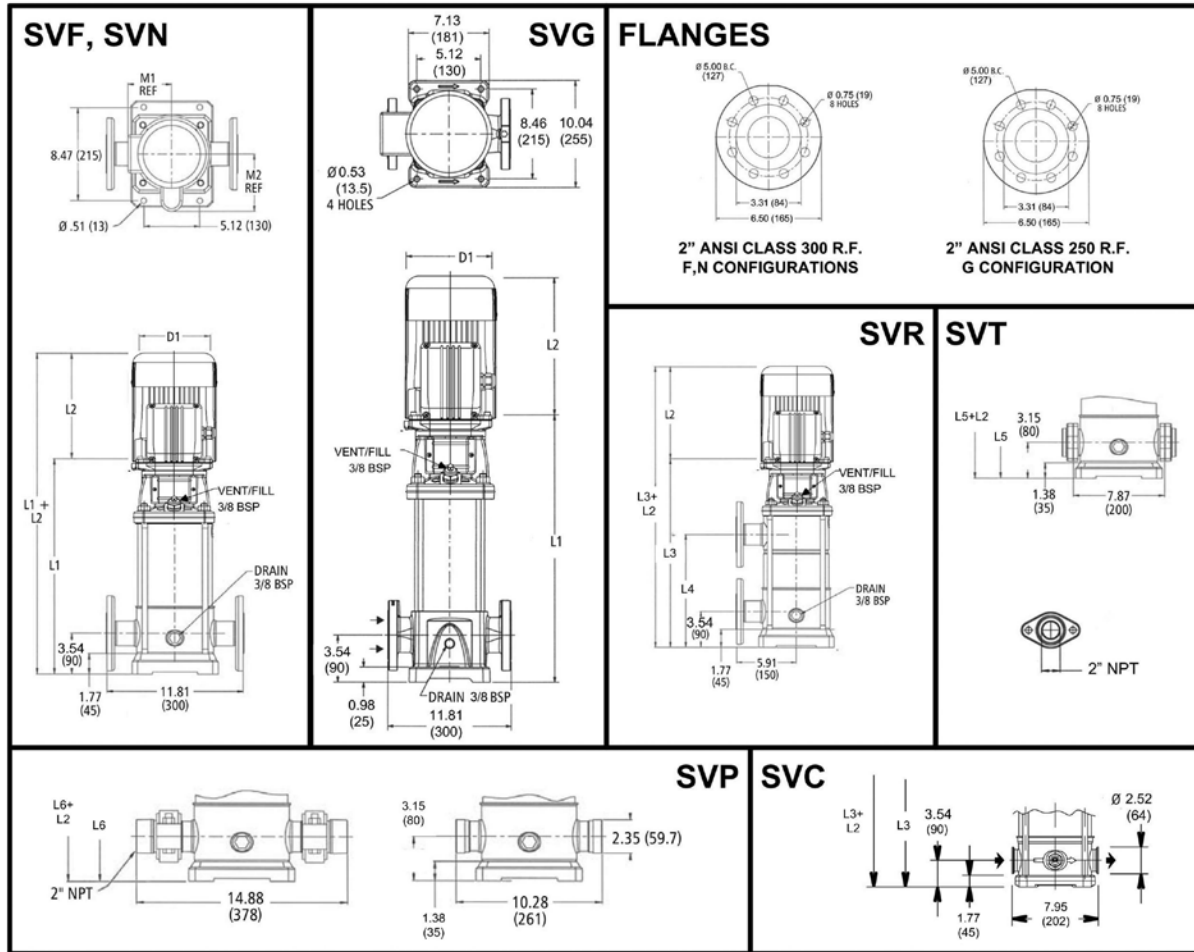

All dimensions are in inches (mm).

Pump Type Stages	Motor					Dimensions (in)											Weight (lbs.)												
	HP	NEMA Frame				L1	L2				L3	L4	L5	L6	M (Ref.)	D1 (max.)				D2	Pump	Motor				Pump/Motor			
		ODP 1Ø	TEFC 1Ø	ODP 3Ø	TEFC 3Ø		ODP 1Ø	TEFC 1Ø	ODP 3Ø	TEFC 3Ø						ODP 1Ø	TEFC 1Ø	ODP 3Ø	TEFC 3Ø			ODP 1Ø	TEFC 1Ø	ODP 3Ø	TEFC 3Ø	ODP 1Ø	TEFC 1Ø	ODP 3Ø	TEFC 3Ø
22SV-01	0.5	56C	18.21	10.79	9.91	9.16	9.29	-	-	17.82	17.82	5.19	6.19	6.19	6.19	6.19	4.13	38	27	29	21	21	65	67	59	59			
22SV-02			18.21	10.79	9.91	9.16	9.29	-	-	17.82	17.82	5.19	6.19	6.19	6.19	6.19	4.13	42	27	29	21	21	69	71	63	63			
22SV-03			20.10	10.79	9.91	9.16	9.29	-	-	19.71	19.71	5.19	6.19	6.19	6.19	6.19	4.13	45	27	29	21	21	72	74	66	66			
22SV-04			21.99	10.66	11.19	9.16	9.29	21.99	11.85	21.60	21.60	5.74	6.19	7.19	6.19	6.19	4.13	48	32	40	23	23	80	88	71	71			
22SV-05			23.90	10.66	11.19	9.16	9.29	23.90	13.74	23.51	23.51	5.74	6.19	7.19	6.19	6.19	4.13	51	32	40	23	23	83	91	74	74			
22SV-06			25.79	10.67	11.19	10.66	9.91	25.79	15.63	25.40	25.40	5.74	6.19	7.19	6.19	6.19	4.72	54	32	40	30	28	86	94	84	82			
22SV-07			27.68	11.18	12.06	11.16	10.79	27.68	17.52	27.29	27.29	5.74	7.19	7.19	6.19	6.19	4.72	57	43	51	32	33	100	108	89	90			
22SV-08			29.57	11.18	12.06	11.16	10.79	29.57	19.41	29.18	29.18	5.74	7.19	7.19	6.19	6.19	4.72	60	43	51	32	33	103	111	92	93			
22SV-09			31.46	11.18	12.06	11.16	10.79	31.46	21.30	31.07	31.07	5.74	7.19	7.19	6.19	6.19	4.72	62	43	51	32	33	105	113	94	95			
22SV-10			33.35	11.18	12.06	11.16	10.79	33.35	23.19	32.96	32.96	5.74	7.19	7.19	6.19	6.19	4.72	66	43	51	32	33	109	117	98	99			
22SV-11			2	35.24	11.57	13.44	11.18	11.16	35.24	25.08	34.85	34.85	5.75	6.5	7.19	7.19	5.51	69	49	64	41	44	118	133	110	113			
22SV-12				37.13	11.57	13.44	11.18	11.16	37.13	26.97	36.74	36.74	5.75	6.5	7.19	7.19	5.51	72	49	64	41	44	121	136	113	116			

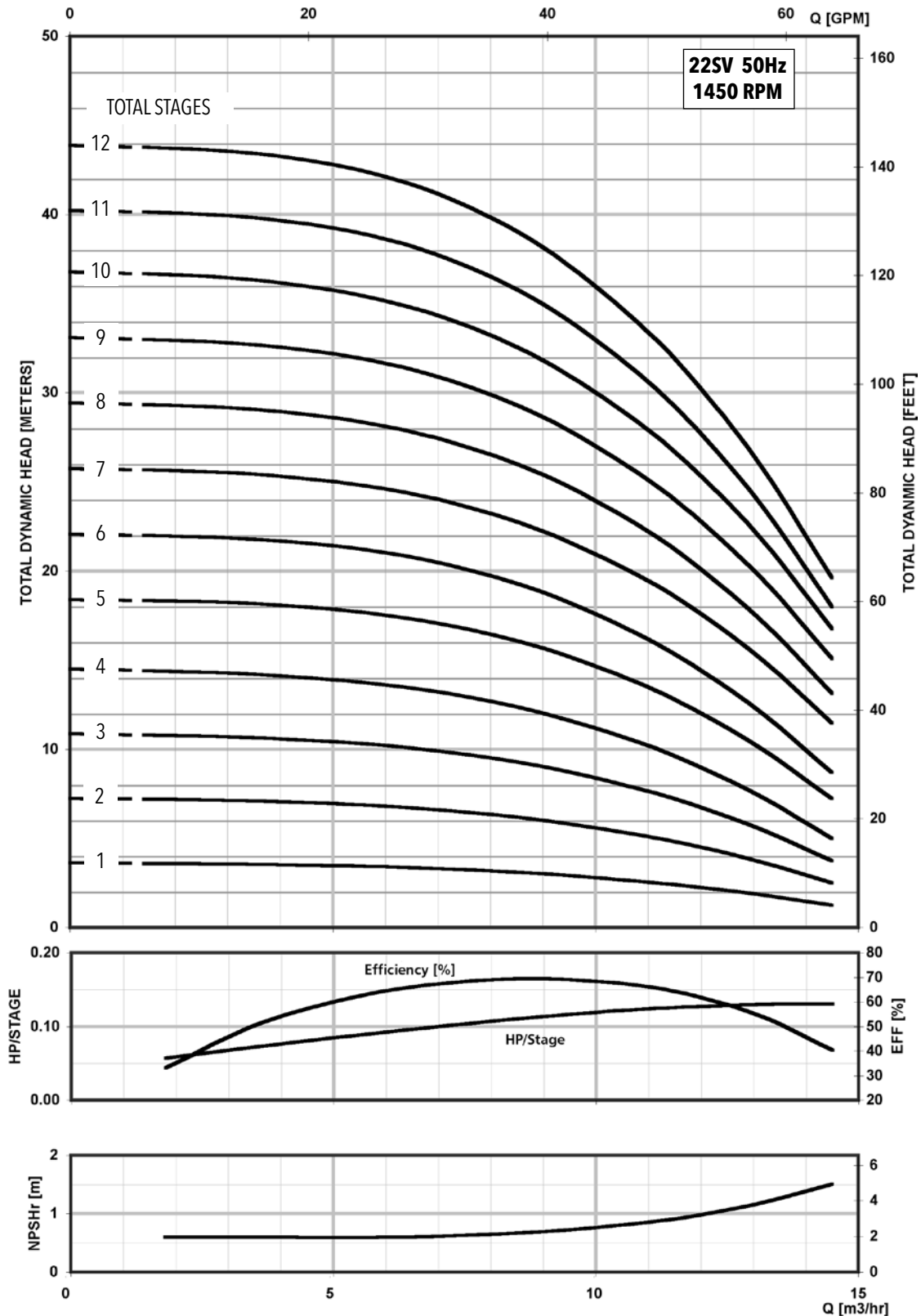

MINIMUM FLOW RATE: 2 m³/hr [9 GPM]

Dimensions and Weights

33SV Series 1450 RPM

50 Hz

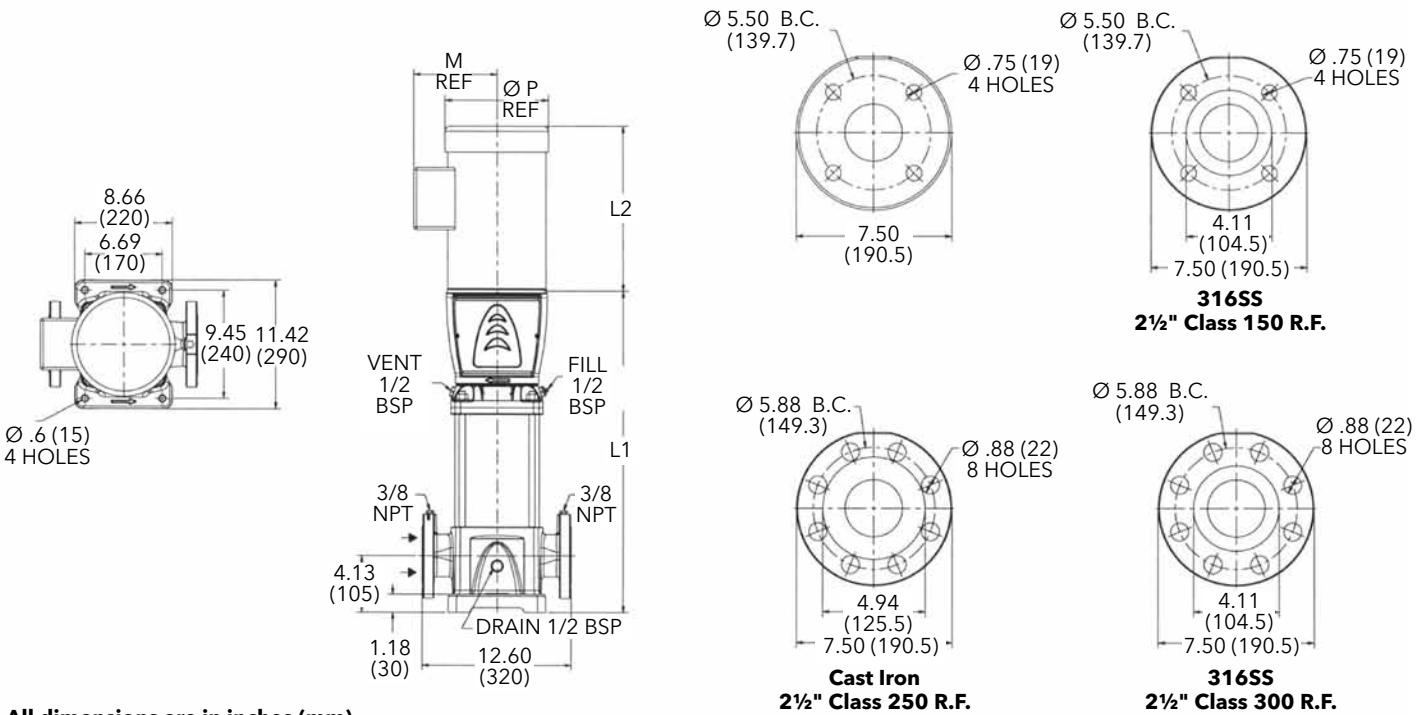

All dimensions are in inches (mm).

Pump Type Stages	Motor					Dimensions (in)										Weight (lbs.)									
	HP	NEMA Frame				L1	L2				M (Ref.)	D1 (max.)				D2	Pump Only	Motor				Pump/Motor			
		ODP 1Ø	TEFC 1Ø	ODP 3Ø	TEFC 3Ø		ODP 1Ø	TEFC 1Ø	ODP 3Ø	TEFC 3Ø		ODP 1Ø	TEFC 1Ø	ODP 3Ø	TEFC 3Ø			ODP 1Ø	TEFC 1Ø	ODP 3Ø	TEFC 3Ø	ODP 1Ø	TEFC 1Ø	ODP 3Ø	TEFC 3Ø
33SV-1	3	182TC	184TC	20.62	13.94	13.94	15.44	15.44	6.88	8.50	8.50	8.50	8.50	5.51	132	81	92	62	69	213	224	194	201		
33SV-2/2				23.58	13.94	13.94	15.44	15.44	6.88	8.50	8.50	8.50	8.50	5.51	143	81	92	62	69	224	235	205	212		
33SV-2/1				23.58	13.94	13.94	15.44	15.44	6.88	8.50	8.50	8.50	8.50	5.51	143	81	92	62	69	224	235	205	212		
33SV-2				23.58	13.94	13.94	15.44	15.44	6.88	8.50	8.50	8.50	8.50	5.51	143	81	92	62	69	224	235	205	212		
33SV-3/2				26.54	13.94	13.94	15.44	15.44	6.88	8.50	8.50	8.50	8.50	5.51	152	81	92	62	69	233	244	214	221		
33SV-3/1				26.54	13.94	13.94	15.44	15.44	6.88	8.50	8.50	8.50	8.50	5.51	152	81	92	62	69	233	244	214	221		
33SV-3				26.54	13.94	13.94	15.44	15.44	6.88	8.50	8.50	8.50	8.50	5.51	152	81	92	62	69	233	244	214	221		
33SV-4/2				29.50	13.94	13.94	15.44	15.44	6.88	8.50	8.50	8.50	8.50	5.51	161	81	92	62	69	242	253	223	230		
33SV-4/1				29.50	13.94	13.94	15.44	15.44	6.88	8.50	8.50	8.50	8.50	5.51	161	81	92	62	69	242	253	223	230		
33SV-4				29.50	13.94	13.94	15.44	15.44	6.88	8.50	8.50	8.50	8.50	5.51	161	81	92	62	69	242	253	223	230		
33SV-5/2				32.44	13.94	13.94	15.44	15.44	6.88	8.50	8.50	8.50	8.50	5.51	172	81	92	62	69	253	264	234	241		
33SV-5/1				32.44	13.94	13.94	15.44	15.44	6.88	8.50	8.50	8.50	8.50	5.51	172	81	92	62	69	253	264	234	241		
33SV-5				32.44	13.94	13.94	15.44	15.44	6.88	8.50	8.50	8.50	8.50	5.51	172	81	92	62	69	253	264	234	241		
33SV-6/2				35.40	13.94	13.94	15.44	15.44	6.88	8.50	8.50	8.50	8.50	5.51	194	81	92	62	69	275	286	256	263		
33SV-6/1				35.40	13.94	13.94	15.44	15.44	6.88	8.50	8.50	8.50	8.50	5.51	194	81	92	62	69	275	286	256	263		
33SV-6				35.40	13.94	13.94	15.44	15.44	6.88	8.50	8.50	8.50	8.50	5.51	194	81	92	62	69	275	286	256	263		
33SV-7/2				38.35	13.94	13.94	15.44	15.44	6.88	8.50	8.50	8.50	8.50	5.51	204	81	92	62	69	285	296	266	273		
33SV-7/1				38.35	13.94	13.94	15.44	15.44	6.88	8.50	8.50	8.50	8.50	5.51	204	81	92	62	69	285	296	266	273		
33SV-7				38.35	13.94	13.94	15.44	15.44	6.88	8.50	8.50	8.50	8.50	5.51	204	81	92	62	69	285	296	266	273		
33SV-8/2				41.30	13.94	13.94	15.44	15.44	6.88	8.50	8.50	8.50	8.50	5.51	221	81	92	62	69	302	313	283	290		
33SV-8/1	41.30	13.94	13.94	15.44	15.44	6.88	8.50	8.50	8.50	8.50	5.51	221	81	92	62	69	302	313	283	290					
33SV-8	41.30	13.94	13.94	15.44	15.44	6.88	8.50	8.50	8.50	8.50	5.51	221	81	92	62	69	302	313	283	290					
33SV-9/2	44.25	13.94	13.94	15.44	15.44	6.88	8.50	8.50	8.50	8.50	5.51	230	81	92	62	69	311	322	292	299					
33SV-9/1	44.25	13.94	13.94	15.44	15.44	6.88	8.50	8.50	8.50	8.50	5.51	230	81	92	62	69	311	322	292	299					
33SV-9	44.25	13.94	13.94	15.44	15.44	6.88	8.50	8.50	8.50	8.50	5.51	230	81	92	62	69	311	322	292	299					
33SV-10/2	47.20	13.94	13.94	15.44	15.44	6.88	8.50	8.50	8.50	8.50	5.51	249	100	120	75	85	349	369	324	334					
33SV-10/1	47.20	13.94	13.94	15.44	15.44	6.88	8.50	8.50	8.50	8.50	5.51	249	100	120	75	85	349	369	324	334					
33SV-10	47.20	13.94	13.94	15.44	15.44	6.88	8.50	8.50	8.50	8.50	5.51	249	100	120	75	85	349	369	324	334					

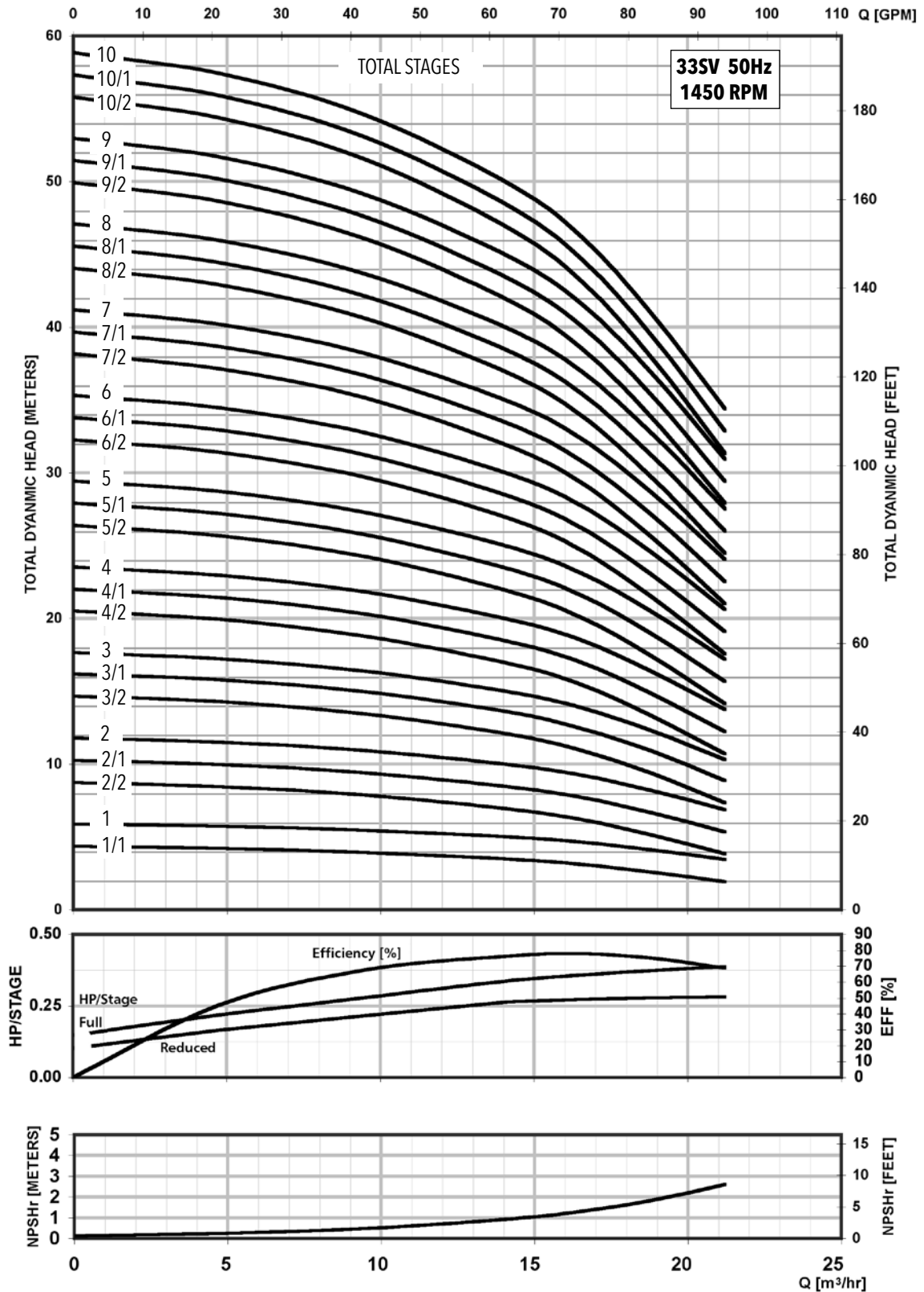

MINIMUM FLOW RATE: 0.9 m³/hr [4 GPM]

Dimensions and Weights

46SV Series 1450 RPM

50 Hz

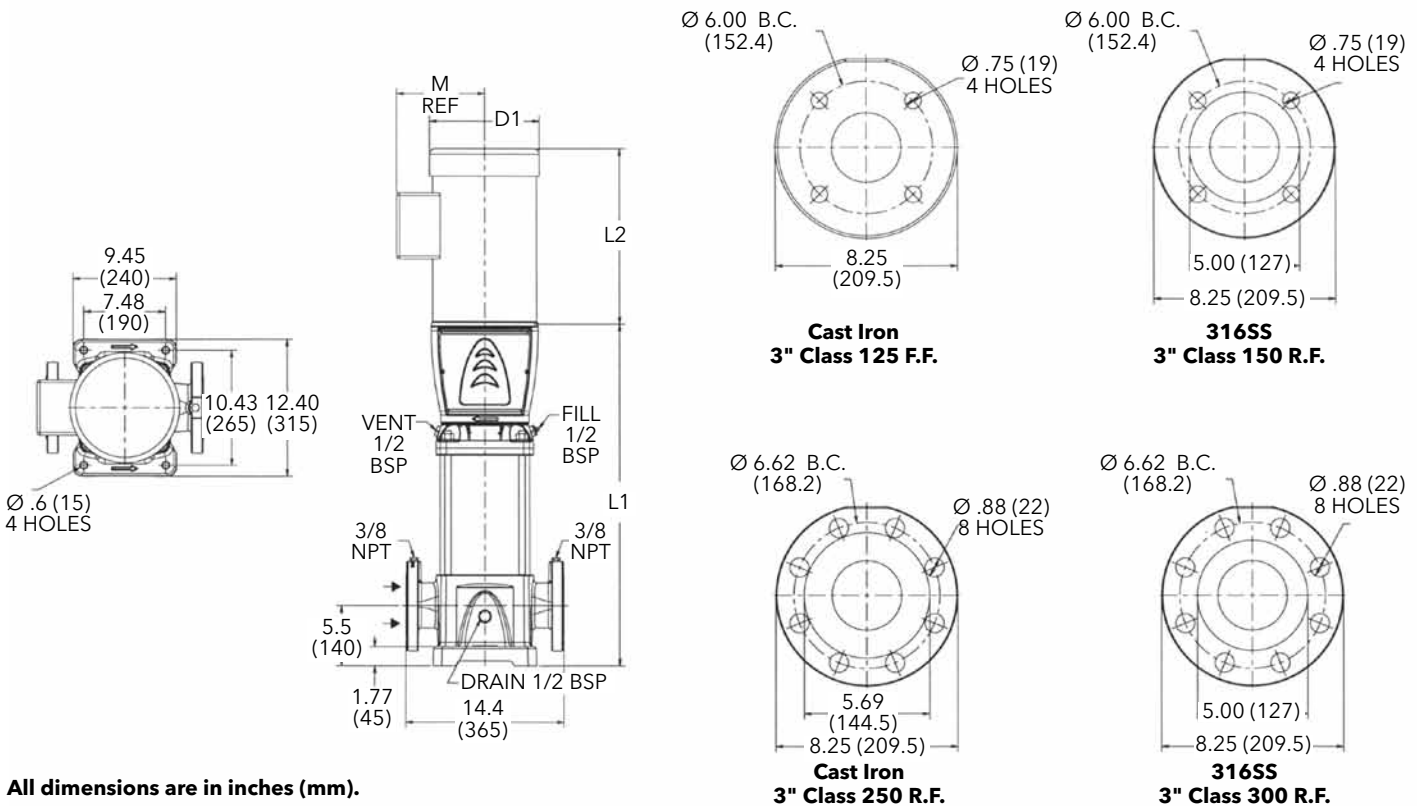

Pump Type Stages	Motor				Dimensions (in)										Weight (lbs.)										
	HP	NEMA Frame				L2					D1 (max.)					D2	Pump Only	Motor				Pump/Motor			
		ODP 1Ø	TEFC 1Ø	ODP 3Ø	TEFC 3Ø	L1	ODP 1Ø	TEFC 1Ø	ODP 3Ø	TEFC 3Ø	M (Ref.)	ODP 1Ø	TEFC 1Ø	ODP 3Ø	TEFC 3Ø			ODP 1Ø	TEFC 1Ø	ODP 3Ø	TEFC 3Ø	ODP 1Ø	TEFC 1Ø	ODP 3Ø	TEFC 3Ø
46SV-1	3	182TC	184TC	22.19	13.94	13.94	15.44	15.44	6.88	8.50	8.50	8.50	8.50	5.51	147	81	92	62	69	228	239	209	216		
46SV-2/2				25.19	13.94	13.94	15.44	15.44	6.88	8.50	8.50	8.50	8.50	5.51	158	81	92	62	69	239	250	220	227		
46SV-2/1				25.19	13.94	13.94	15.44	15.44	6.88	8.50	8.50	8.50	8.50	5.51	158	81	92	62	69	239	250	220	227		
46SV-2				25.19	13.94	13.94	15.44	15.44	6.88	8.50	8.50	8.50	8.50	5.51	158	81	92	62	69	239	250	220	227		
46SV-3/2				28.12	13.94	13.94	15.44	15.44	6.88	8.50	8.50	8.50	8.50	5.51	169	81	92	62	69	250	261	231	238		
46SV-3/1				28.12	13.94	13.94	15.44	15.44	6.88	8.50	8.50	8.50	8.50	5.51	169	81	92	62	69	250	261	231	238		
46SV-3				28.12	13.94	13.94	15.44	15.44	6.88	8.50	8.50	8.50	8.50	5.51	169	81	92	62	69	250	261	231	238		
46SV-4/2				32.63	13.94	13.94	15.44	15.44	6.88	8.50	8.50	8.50	8.50	5.51	185	81	92	62	69	266	277	247	254		
46SV-4/1				32.63	13.94	13.94	15.44	15.44	6.88	8.50	8.50	8.50	8.50	5.51	185	81	92	62	69	266	277	247	254		
46SV-4				32.63	13.94	13.94	15.44	15.44	6.88	8.50	8.50	8.50	8.50	5.51	185	81	92	62	69	266	277	247	254		
46SV-5/2				35.56	13.94	13.94	15.44	15.44	6.88	8.50	8.50	8.50	8.50	5.51	199	81	92	62	69	280	291	261	268		
46SV-5/1				35.56	13.94	13.94	15.44	15.44	6.88	8.50	8.50	8.50	8.50	5.51	199	81	92	62	69	280	291	261	268		
46SV-5				35.56	13.94	13.94	15.44	15.44	6.88	8.50	8.50	8.50	8.50	5.51	199	81	92	62	69	280	291	261	268		
46SV-6/2				38.50	13.94	15.44	13.94	15.44	6.88	8.50	8.50	8.50	8.50	5.51	208	100	120	75	85	308	328	283	293		
46SV-6/1				38.50	13.94	15.44	13.94	15.44	6.88	8.50	8.50	8.50	8.50	5.51	208	100	120	75	85	308	328	283	293		
46SV-6				38.50	13.94	15.44	13.94	15.44	6.88	8.50	8.50	8.50	8.50	5.51	208	100	120	75	85	308	328	283	293		
46SV-7/2				40.94	13.94	15.44	13.94	15.44	6.88	8.50	8.50	8.50	8.50	5.51	225	100	120	75	85	325	345	300	310		
46SV-7/1				40.94	13.94	15.44	13.94	15.44	6.88	8.50	8.50	8.50	8.50	5.51	225	100	120	75	85	325	345	300	310		
46SV-7				40.94	13.94	15.44	13.94	15.44	6.88	8.50	8.50	8.50	8.50	5.51	225	100	120	75	85	325	345	300	310		
46SV-8/2				43.94	13.94	15.44	13.94	15.44	6.88	8.50	8.50	8.50	8.50	5.51	234	100	120	75	85	334	354	309	319		
46SV-8/1	43.94	13.94	15.44	13.94	15.44	6.88	8.50	8.50	8.50	8.50	5.51	234	100	120	75	85	334	354	309	319					
46SV-8	43.94	13.94	15.44	13.94	15.44	6.88	8.50	8.50	8.50	8.50	5.51	234	100	120	75	85	334	354	309	319					
46SV-9/2	46.88	13.94	15.44	13.94	15.44	6.88	8.50	8.50	8.50	8.50	5.51	253	100	120	75	85	353	373	328	338					
46SV-9/1	46.88	13.94	15.44	13.94	15.44	6.88	8.50	8.50	8.50	8.50	5.51	253	100	120	75	85	353	373	328	338					
46SV-9	46.88	13.94	15.44	13.94	15.44	6.88	8.50	8.50	8.50	8.50	5.51	253	100	120	75	85	353	373	328	338					
46SV-10/2	49.81	13.94	15.44	13.94	15.44	6.88	8.50	8.50	8.50	8.50	5.51	264	100	120	75	85	364	384	339	349					

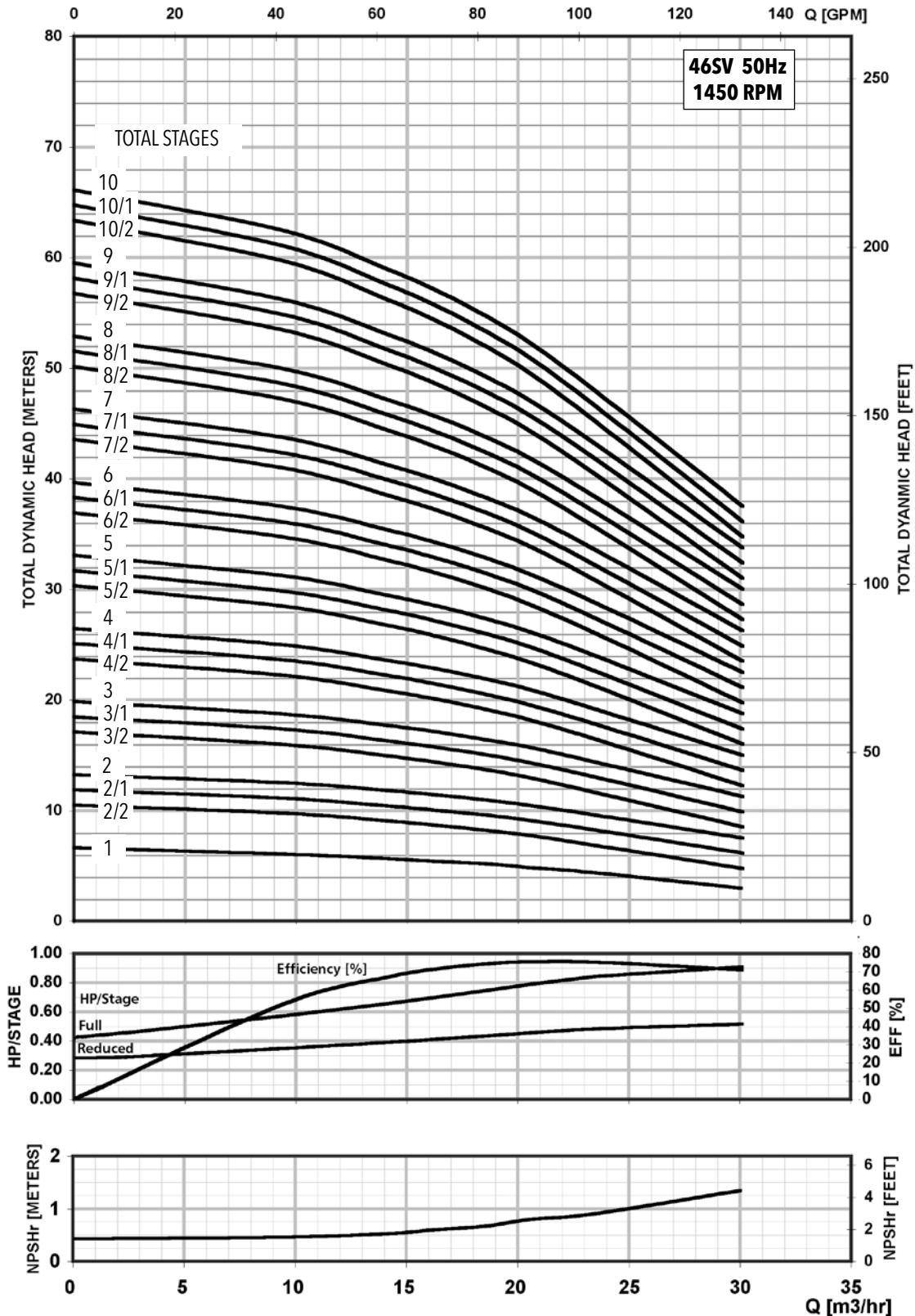

MINIMUM FLOW RATE: 1.1 m³/hr [5 GPM]

Dimensions and Weights

66SV Series 1450 RPM

50 Hz

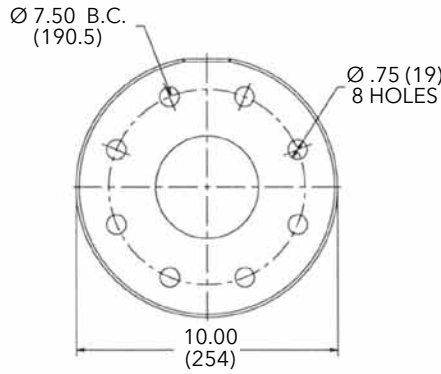
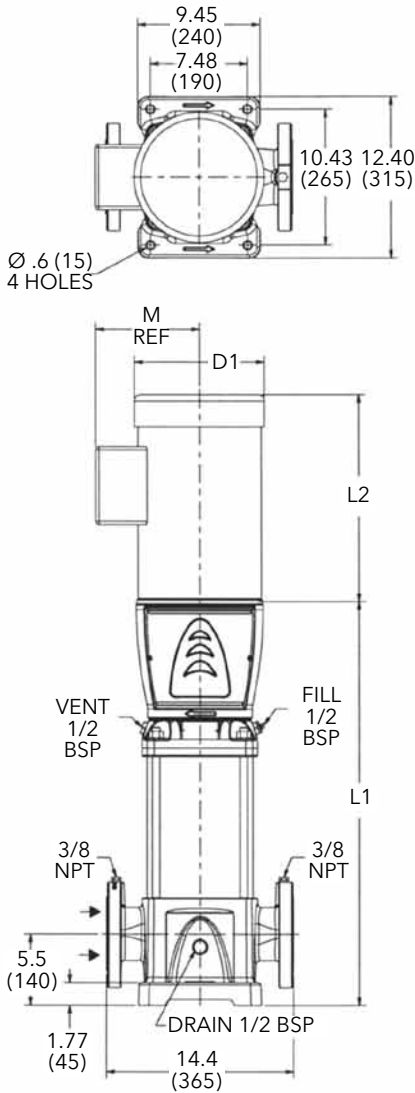

Cast Iron
4" Class 125 F.F.

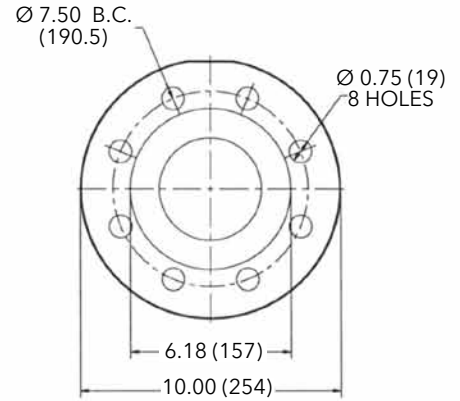

316SS
4" Class 150 R.F.

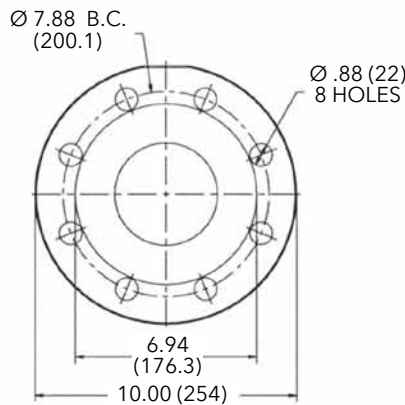

Cast Iron
4" Class 250 R.F.

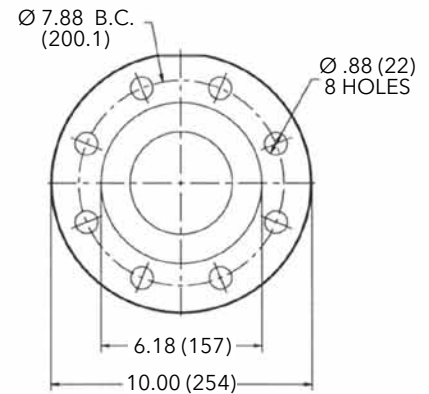

316SS
4" Class 300 R.F.

All dimensions are in inches (mm).

Pump Type Stages	Motor				Dimensions (in)								Weight (lbs.)											
	HP	NEMA Frame			L1	L2				M (Ref.)	D1 (max.)				D2	Pump Only	Motor				Pump/Motor			
		ODP 1Ø	TEFC 1Ø	ODP 3Ø		TEFC 3Ø	ODP 1Ø	TEFC 1Ø	ODP 3Ø		TEFC 3Ø	ODP 1Ø	TEFC 1Ø	ODP 3Ø			TEFC 3Ø	ODP 1Ø	TEFC 1Ø	ODP 3Ø	TEFC 3Ø			
66SV-1	3	184TC	23.19	13.94	13.94	15.44	15.44	6.88	8.50	8.50	8.50	8.50	5.51	185	81	92	62	69	266	277	247	254		
66SV-2/2			26.75	13.94	13.94	15.44	15.44	6.88	8.50	8.50	8.50	8.50	5.51	196	81	92	62	69	277	288	258	265		
66SV-2/1			26.75	13.94	13.94	15.44	15.44	6.88	8.50	8.50	8.50	8.50	5.51	196	81	92	62	69	277	288	258	265		
66SV-2			26.75	13.94	13.94	15.44	15.44	6.88	8.50	8.50	8.50	8.50	5.51	196	81	92	62	69	277	288	258	265		
66SV-3/2			31.81	13.94	13.94	15.44	15.44	6.88	8.50	8.50	8.50	8.50	5.51	223	81	92	62	69	304	315	285	292		
66SV-3/1			31.81	13.94	13.94	15.44	15.44	6.88	8.50	8.50	8.50	8.50	5.51	223	81	92	62	69	304	315	285	292		
66SV-3			31.81	13.94	13.94	15.44	15.44	6.88	8.50	8.50	8.50	8.50	5.51	223	81	92	62	69	304	315	285	292		
66SV-4/2			35.38	13.94	13.94	15.44	15.44	6.88	8.50	8.50	8.50	8.50	5.51	234	81	92	62	69	315	326	296	303		
66SV-4/1			35.38	13.94	13.94	15.44	15.44	6.88	8.50	8.50	8.50	8.50	5.51	234	81	92	62	69	315	326	296	303		
66SV-4			35.38	13.94	13.94	15.44	15.44	6.88	8.50	8.50	8.50	8.50	5.51	234	81	92	62	69	315	326	296	303		
66SV-5/2			5	39.44	13.94	15.44	13.94	15.44	6.88	8.50	8.50	8.50	8.50	5.51	244	100	120	75	85	344	364	319	329	
66SV-5/1				39.44	13.94	15.44	13.94	15.44	6.88	8.50	8.50	8.50	8.50	5.51	244	100	120	75	85	344	364	319	329	
66SV-5	39.44	13.94		15.44	13.94	15.44	6.88	8.50	8.50	8.50	8.50	5.51	244	100	120	75	85	344	364	319	329			
66SV-6/2	41.94	13.94		15.44	13.94	15.44	6.88	8.50	8.50	8.50	8.50	5.51	266	100	120	75	85	366	386	341	351			
66SV-6/1	41.94	13.94		15.44	13.94	15.44	6.88	8.50	8.50	8.50	8.50	5.51	266	100	120	75	85	366	386	341	351			
66SV-6	41.94	13.94		15.44	13.94	15.44	6.88	8.50	8.50	8.50	8.50	5.51	266	100	120	75	85	366	386	341	351			

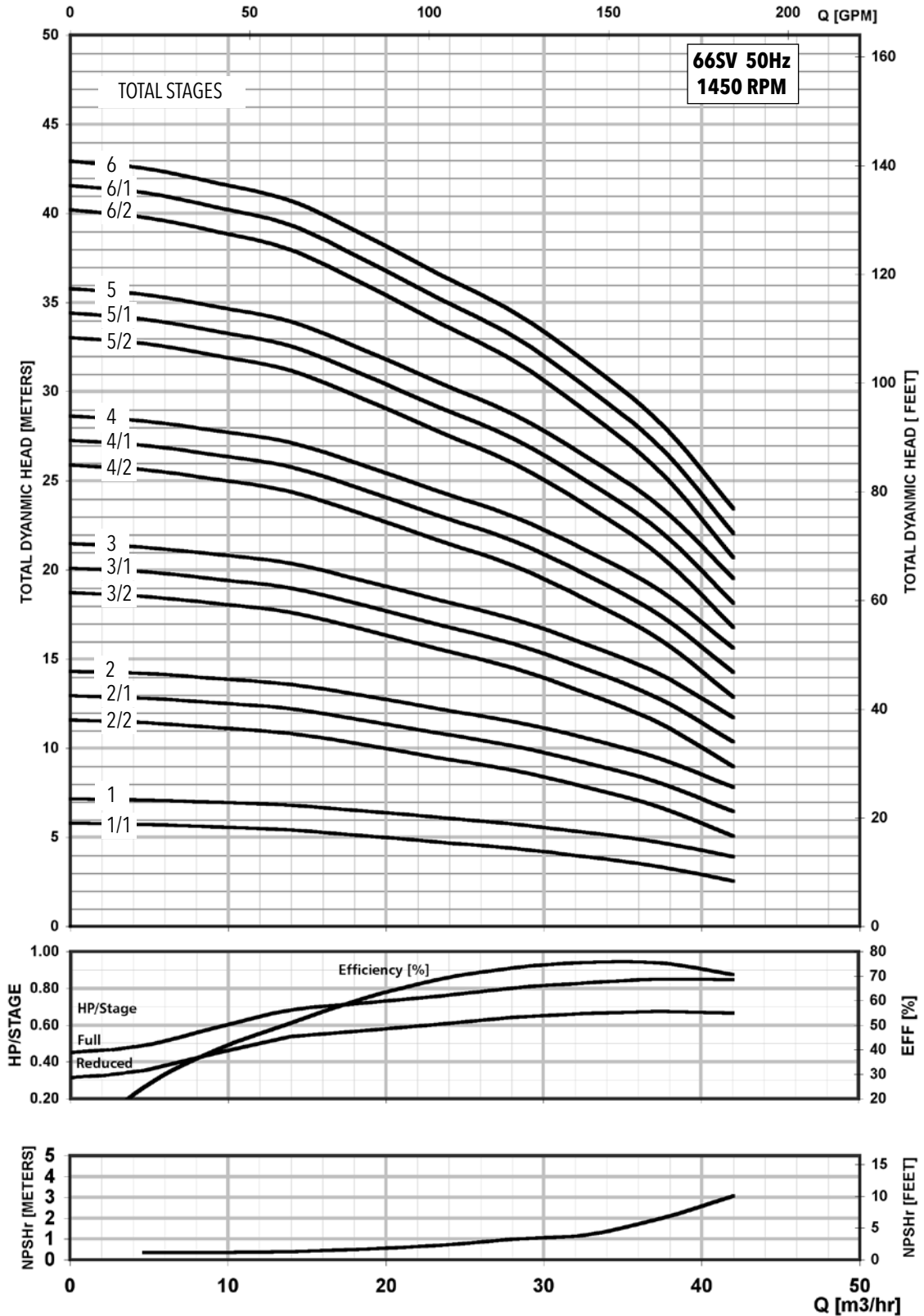

MINIMUM FLOW RATE: 1.6 m³/hr [7 GPM]

Dimensions and Weights

92SV Series 1450 RPM

50 Hz

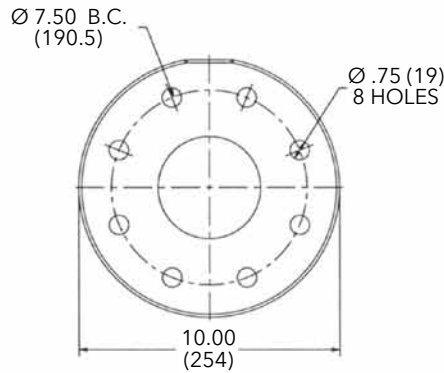
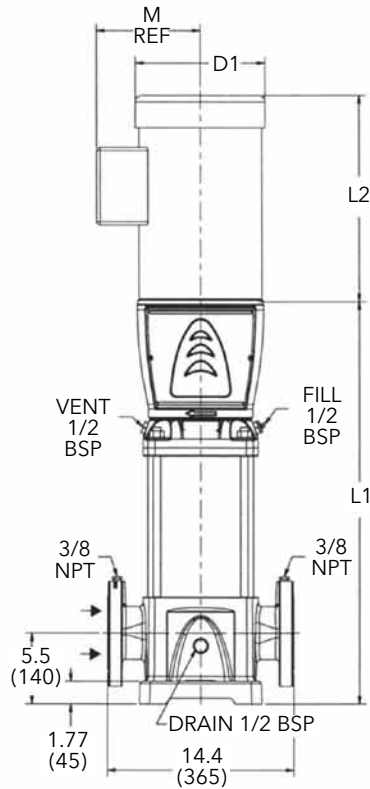
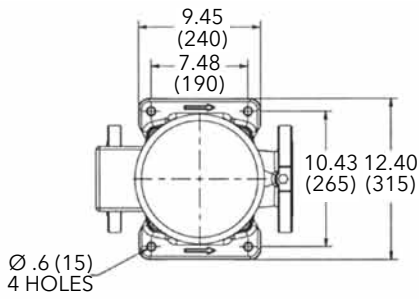

Cast Iron
4" Class 125 F.F.

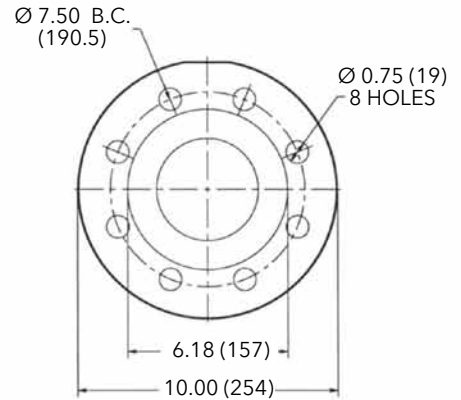

316SS
4" Class 150 R.F.

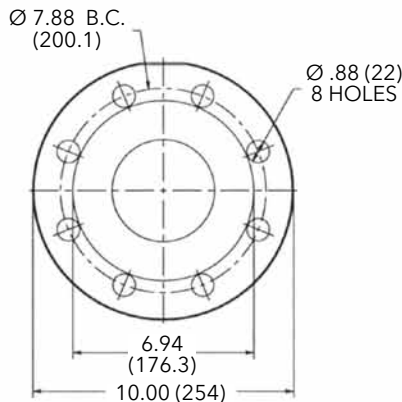

Cast Iron
4" Class 250 R.F.

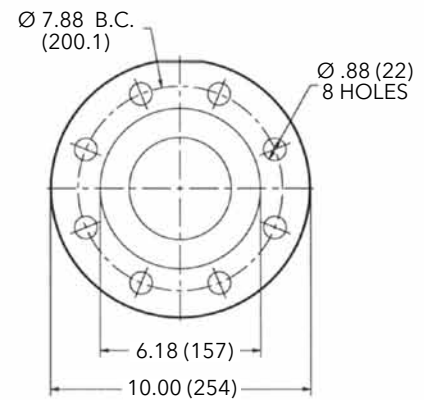

316SS
4" Class 300 R.F.

All dimensions are in inches (mm).

Pump Type Stages	Motor				Dimensions (in)										Weight (lbs.)											
	HP	NEMA Frame			L1	L2				M (Ref.)	D1 (max.)				D2	Pump Only	Motor				Pump/Motor					
		ODP 10	TEFC 10	ODP 30		TEFC 30	ODP 10	TEFC 10	ODP 30		TEFC 30	ODP 10	TEFC 10	ODP 30			TEFC 30	ODP 10	TEFC 10	ODP 30	TEFC 30	ODP 10	TEFC 10	ODP 30	TEFC 30	
92SV-1	3	184TC			23.19	13.94	13.94	15.44	15.44	6.88	8.50	8.50	8.50	8.50	5.51	185	81	92	62	69	266	277	247	254		
92SV-2/2					28.31	13.94	13.94	15.44	15.44	6.88	8.50	8.50	8.50	8.50	5.51	196	81	92	62	69	277	288	258	265		
92SV-2/1					28.31	13.94	15.44	13.94	15.44	6.88	8.50	8.50	8.50	8.50	5.51	196	81	92	62	69	277	288	258	265		
92SV-2					28.31	13.94	15.44	13.94	15.44	6.88	8.50	8.50	8.50	8.50	5.51	196	81	92	62	69	277	288	258	265		
92SV-3/2					31.18	13.94	13.94	15.44	15.44	6.88	8.50	8.50	8.50	8.50	5.51	223	81	92	62	69	304	315	285	292		
92SV-3/1					31.18	13.94	13.94	15.44	15.44	6.88	8.50	8.50	8.50	8.50	5.51	223	81	92	62	69	304	315	285	292		
92SV-3					31.28	13.94	15.44	13.94	15.44	6.88	8.50	8.50	8.50	8.50	5.51	223	81	92	62	69	304	315	285	292		
92SV-4/2			5	184TC			34.88	13.94	15.44	13.94	15.44	6.88	8.50	8.50	8.50	8.50	5.51	234	100	120	75	85	334	354	309	319
92SV-4/1							34.88	13.94	13.94	15.44	15.44	6.88	8.50	8.50	8.50	8.50	5.51	234	100	120	75	85	334	354	309	319
92SV-4							34.88	13.94	13.94	15.44	15.44	6.88	8.50	8.50	8.50	8.50	5.51	234	100	120	75	85	334	354	309	319
92SV-5/2							38.44	13.94	15.44	13.94	15.44	6.88	8.50	8.50	8.50	8.50	5.51	252	100	120	75	85	352	372	327	337
92SV-5/1							38.44	13.94	15.44	13.94	15.44	6.88	8.50	8.50	8.50	8.50	5.51	252	100	120	75	85	352	372	327	337
92SV-5					38.44	13.94	13.94	15.44	15.44	6.88	8.50	8.50	8.50	8.50	5.51	252	100	120	75	85	352	372	327	337		
92SV-6/2					41.94	13.94	13.94	15.44	15.44	6.88	8.50	8.50	8.50	8.50	5.51	266	100	120	75	85	366	386	341	351		
92SV-6/1					41.94	13.94	15.44	13.94	15.44	6.88	8.50	8.50	8.50	8.50	5.51	266	100	120	75	85	366	386	341	351		
92SV-6					41.94	13.94	15.44	13.94	15.44	6.88	8.50	8.50	8.50	8.50	5.51	266	100	120	75	85	366	386	341	351		

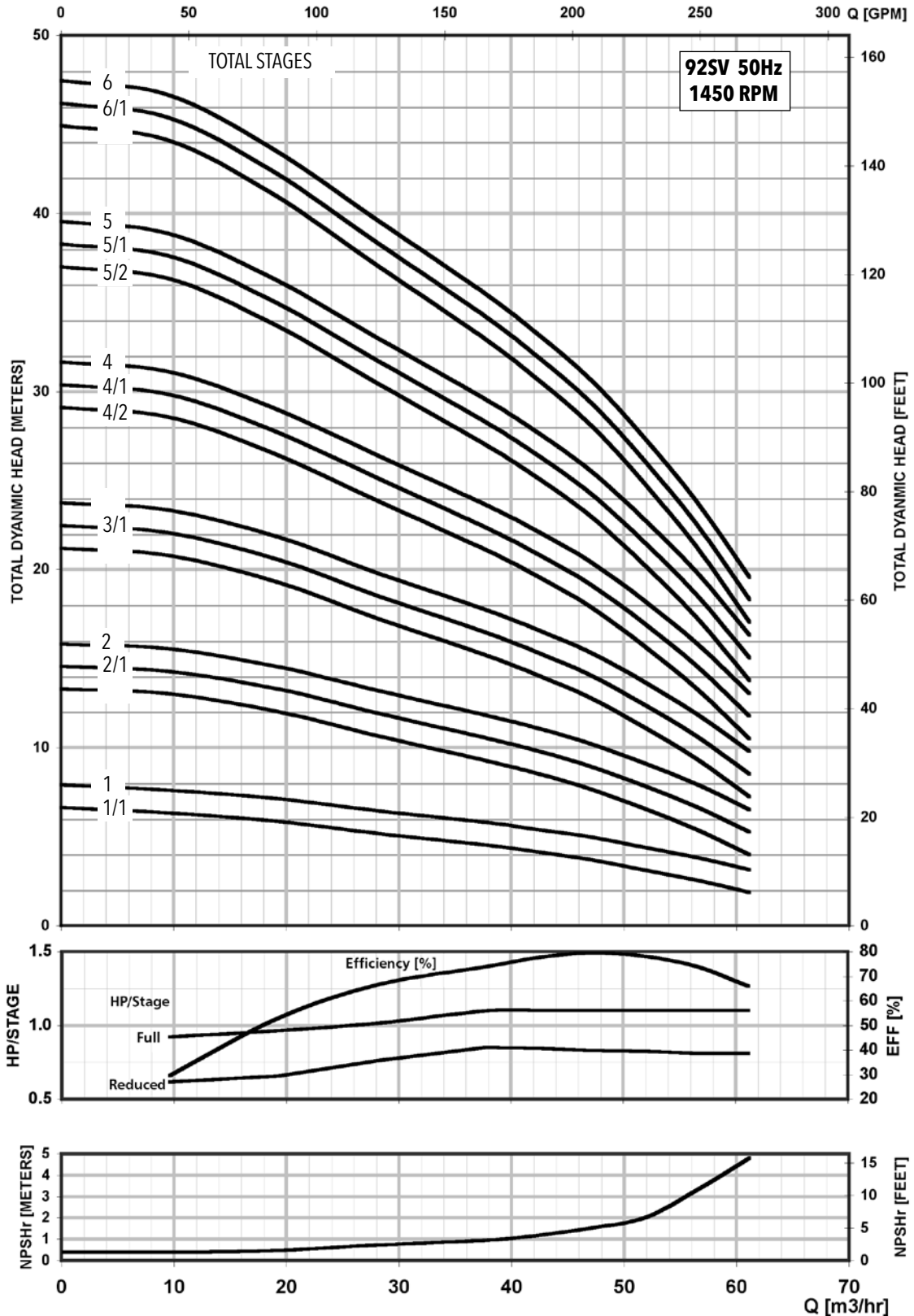

MINIMUM FLOW RATE: 2.3 m³/hr [10 GPM]

Dimensions and Weights

125SV Series 1450 RPM

50 Hz

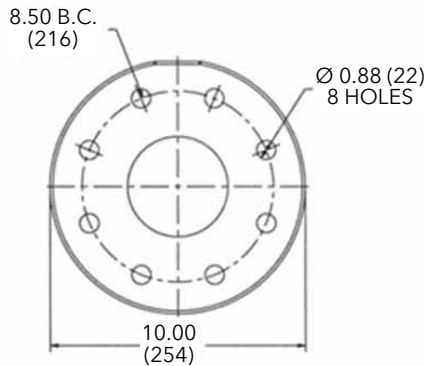
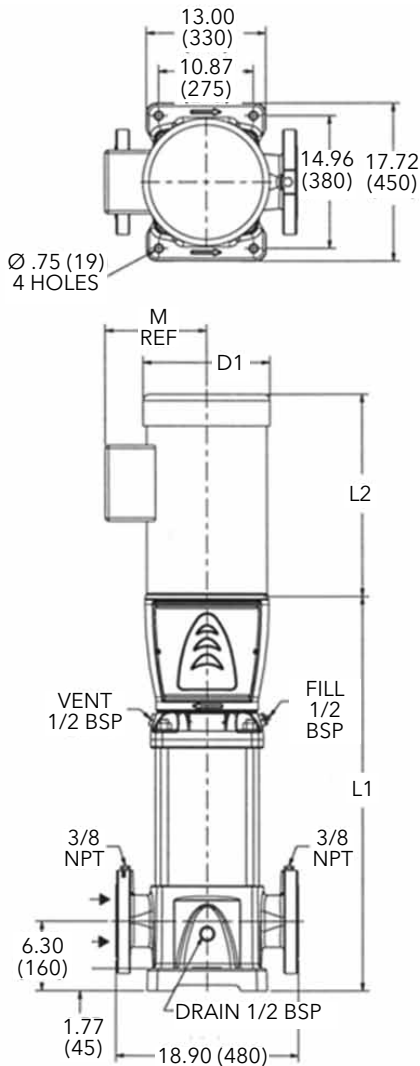

**Cast Iron
5" Class 125 F.F.**

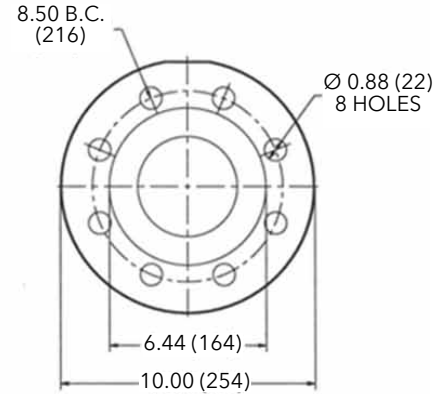

**316SS
5" Class 150 R.F.**

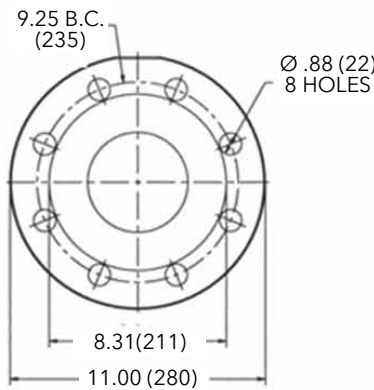

**Cast Iron
5" Class 250 R.F.**

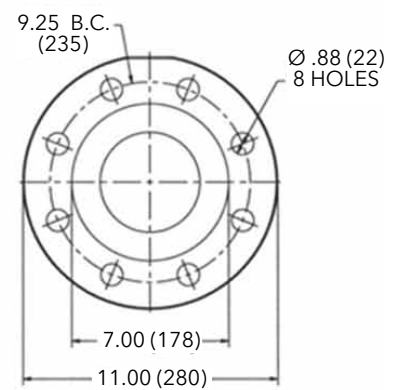

**316SS
5" Class 300 R.F.**

All dimensions are in inches (mm).

Pump Type	HP	Motor				Dimensions (in)														Weight (lbs.)									
		NEMA Frame				L1	L2				L3	L4	L5	L6	M (Ref.)	D1 (max.)				D2	Pump	Motor				Pump/Motor			
		ODP 10	TEFC 10	ODP 30	TEFC 30		ODP 10	TEFC 10	ODP 30	TEFC 30						ODP 10	TEFC 10	ODP 30	TEFC 30			ODP 10	TEFC 10	ODP 30	TEFC 30	ODP 10	TEFC 10	ODP 30	TEFC 30
125SV10C	3	184TC	184TC	182TC	184TC	27.30	13.93	15.43	12.55	13.93	-	-	-	-	6.87	8.88	8.86	9.02	8.86	5.51	256	81	92	62	69	-	-	318	325
125SV20C	3	184TC	184TC	182TC	184TC	34.60	13.93	15.43	12.55	13.93	-	-	-	-	6.87	8.88	8.86	9.02	8.86	5.51	289	81	92	62	69	-	-	351	358
125SV30C	3	184TC	184TC	182TC	184TC	40.50	13.93	15.43	12.55	13.93	-	-	-	-	6.87	8.88	8.86	9.02	8.86	5.51	315	81	92	62	69	-	-	377	384
125SV40C	5	213TC	213TC	184TC	184TC	46.40	13.88	15.53	13.93	15.43	-	-	-	-	8.05	8.89	10.62	8.88	8.86	5.51	355	100	120	75	85	-	-	430	440
125SV50C	5	213TC	213TC	184TC	184TC	52.30	13.88	15.53	13.93	15.43	-	-	-	-	8.05	8.89	10.62	8.88	8.86	5.51	379	100	120	75	85	-	-	454	464
125SV60C	7.5	215TC	215TC	213TC	215TC	58.20	16.63	16.68	15.55	15.51	-	-	-	-	8.77	10.62	10.18	10.18	10.28	4.13	412	132	145	107	122	-	-	519	534
125SV70C	7.5	215TC	215TC	213TC	215TC	65.30	16.63	16.68	15.55	15.51	-	-	-	-	8.77	10.62	10.18	10.18	10.28	4.13	476	132	145	107	122	-	-	583	598
125SV80C	10	-	-	215TC	254TC	71.10	-	-	15.55	16.57	-	-	-	-	9.22	-	-	10.18	10.28	4.72	494	-	-	125	195	-	-	619	689

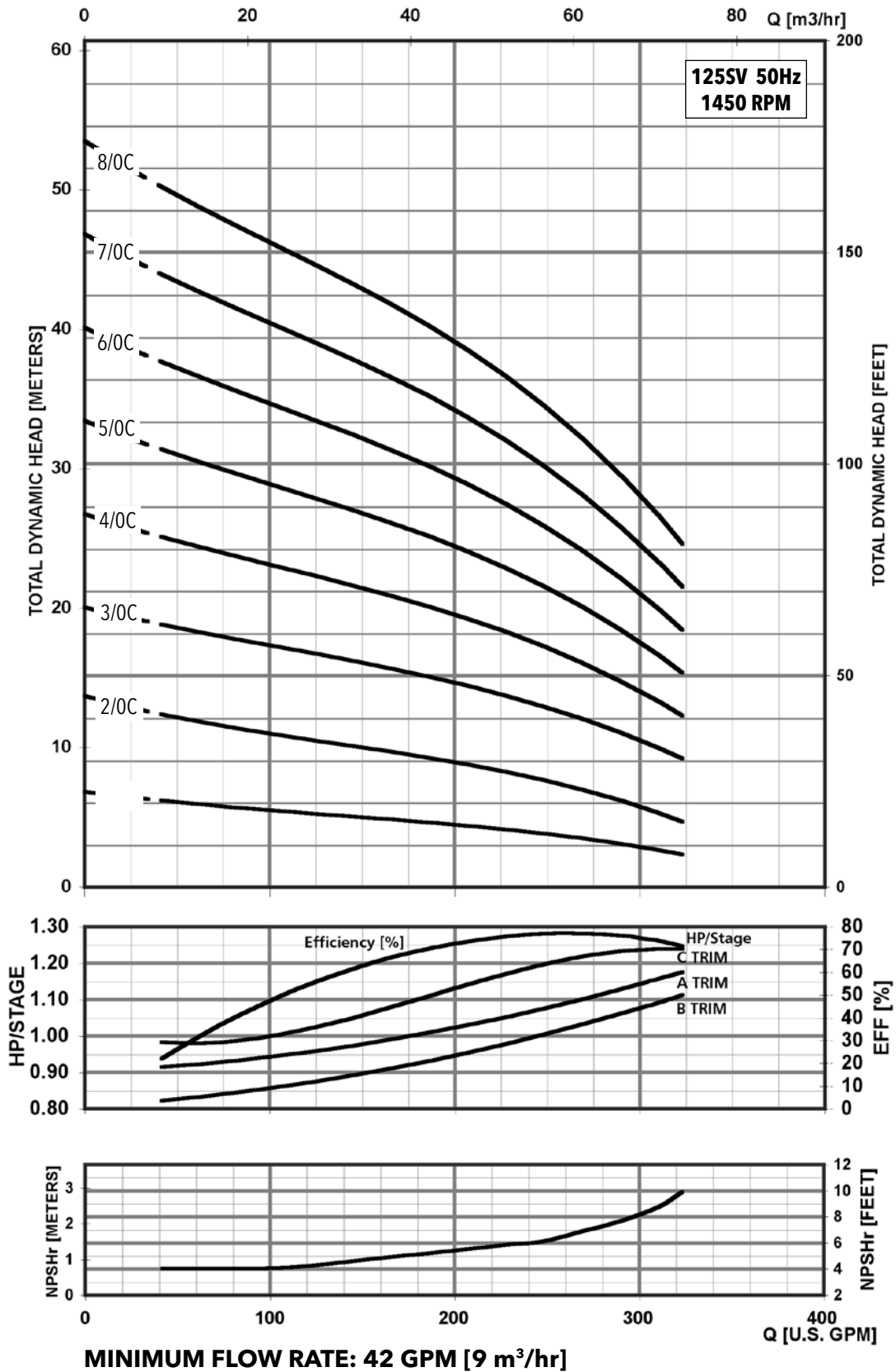

Commercial Water

1SV - 22SV Horizontal Mounting Option

- Consists of e-SV pump with base mounting foot and footed motor for horizontal installations.
- Unit depicted may not show actual pump configuration. Use for mounting location only.

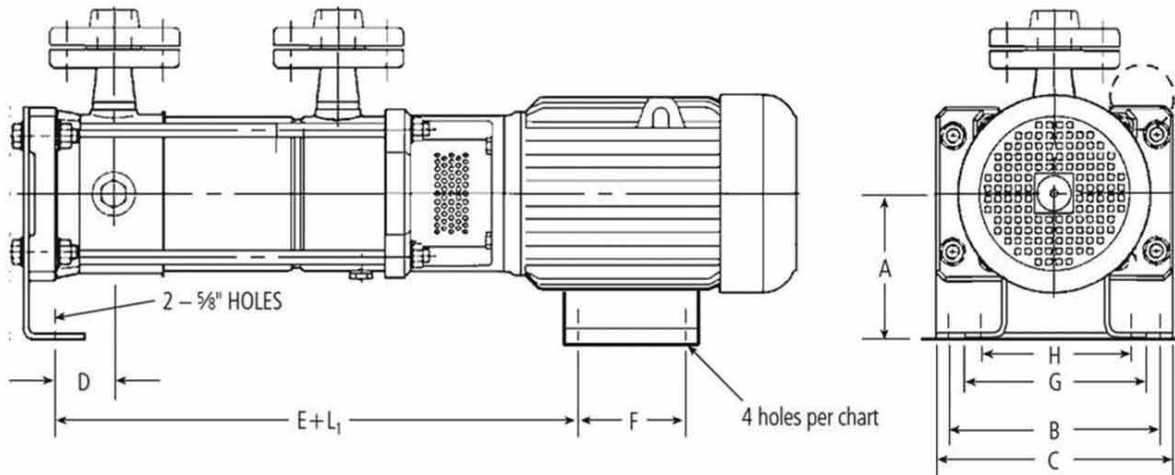

Flanges can be rotated 90° left or right.

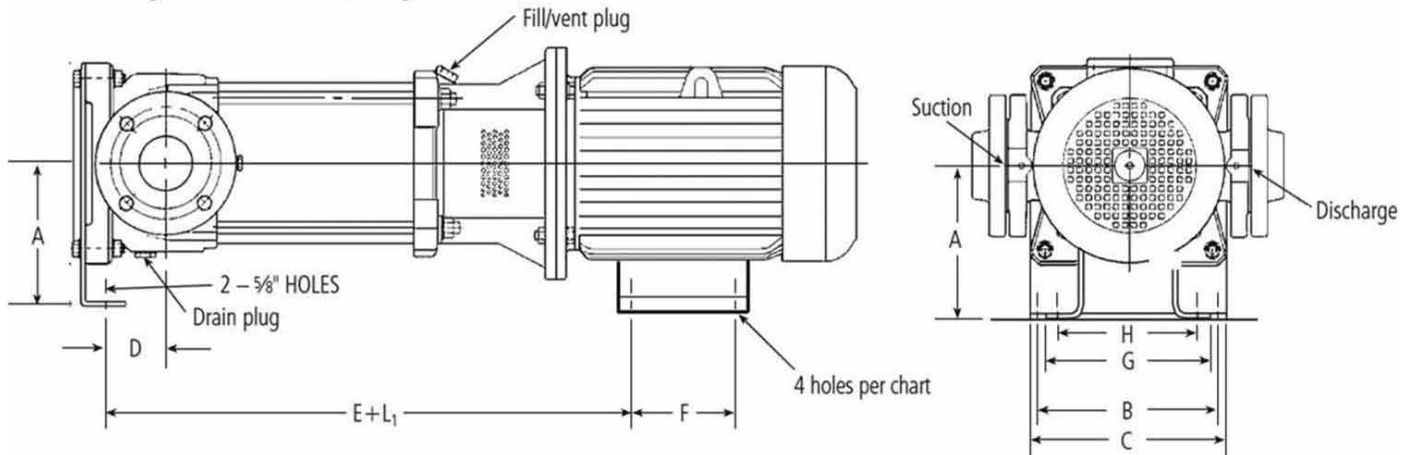

1SV - 22SV Horizontal Mounting Option

Series	Motor Frame	Flange	A	B	C	D	E	F	G	H	Motor Shim Thickness	Pump Shim Thickness
1SV	56C	T	4.5	7	9	0.219	0.810	3	6.563	4.825	1	-
		F, N, P, G, C	4.5	7	9	1.125	0.810	3	6.563	4.825	1	-
		R	4.5	11	12	1.254	0.940	3	6.563	4.825	1	-
3SV	56C	T	4.5	7	9	0.219	0.81	3	6.563	4.825	1	-
		F, N, P, G, C	4.5	7	9	1.125	0.81	3	6.563	4.825	1	-
		R	4.5	11	12	1.254	0.94	3	6.563	4.825	1	-
	180TC	T	4.5	7	9	0.219	1.88	5.5	6.563	4.825	-	-
		F, N, P, G, C	4.5	7	9	1.125	1.88	5.5	6.563	4.825	-	-
	210TC	T	4.5	7	9	0.219	2.5	7	6.563	4.825	-	0.75
F, N, P, G, C		4.5	7	9	1.125	2.5	7	6.563	4.825	-	0.75	
5SV	56C	T	4.5	7	9	0.219	0.81	3	6.563	4.825	1	-
		F, N, P, G, C	4.5	7	9	1.125	0.81	3	6.563	4.825	1	-
		R	4.5	11	12	1.254	0.94	3	6.563	4.825	1	-
	180TC	T	4.5	7	9	0.219	1.88	5.5	6.563	4.825	-	-
		F, N, P, G, C	4.5	7	9	1.125	1.88	5.5	6.563	4.825	-	-
	210TC	T	4.5	7	9	0.219	2.5	7	6.563	4.825	-	0.75
F, N, P, G, C		4.5	7	9	1.125	2.5	7	6.563	4.825	-	0.75	
10SV	56C	T	6.25	9.125	10.50	1.59	1	3	6.563	4.825	2.75	-
		F, N, P, G, C	6.25	9.125	10.50	1.983	1	3	6.563	4.825	2.75	-
		R	6.25	11.875	13.25	1.983	1	3	6.563	4.825	1	-
	180TC	T	6.25	9.125	10.50	1.59	2.07	5.5	8.625	7.50	1.75	-
		F, N, P, G, C	6.25	9.125	10.50	1.983	2.07	5.5	8.625	7.50	1.75	-
	210TC	T	6.25	9.125	10.50	1.59	2.69	7	9.500	8.50	1	-
F, N, P, G, C		6.25	9.125	10.50	1.983	2.69	7	9.500	8.50	1	-	
15SV	56C	T	6.25	9.125	10.50	1.59	1	3	6.563	4.825	2.75	-
		F, N, P, G, C	6.25	9.125	10.50	1.983	1	3	6.563	4.825	2.75	-
		R	6.25	11.875	13.25	1.983	1	3	6.563	4.825	1	-
	180TC	T	6.25	9.125	10.50	1.59	2.07	5.5	8.625	7.50	1.75	-
		F, N, P, G, C	6.25	9.125	10.50	1.983	2.07	5.5	8.625	7.50	1.75	-
	210TC	T	6.25	9.125	10.50	1.59	2.69	7	9.500	8.50	1	-
F, N, P, G, C		6.25	9.125	10.50	1.983	2.69	7	9.500	8.50	1	-	
22SV	56C	T	6.25	9.125	10.50	1.59	1	3	6.563	4.825	2.75	-
		F, N, P, G, C	6.25	9.125	10.50	1.983	1	3	6.563	4.825	2.75	-
		R	6.25	11.875	13.25	1.983	1	3	6.563	4.825	1	-
	180TC	T	6.25	9.125	10.50	1.59	2.07	5.5	8.625	7.50	1.75	-
		F, N, P, G, C	6.25	9.125	10.50	1.983	2.07	5.5	8.625	7.50	1.75	-
	210TC	T	6.25	9.125	10.50	1.59	2.69	7	9.500	8.50	1	-
F, N, P, G, C		6.25	9.125	10.50	1.983	2.69	7	9.500	8.50	1	-	
22SV	250TC	T	6.25	9.125	10.50	1.59	3.19	10	11.500	10.00	-	-
		F, N, P, G, C	6.25	9.125	10.50	1.983	3.19	10	11.500	10.00	-	-
		R	6.25	11.875	13.25	1.983	3.19	10	11.500	10.00	-	1.75
	280TC	T	6.25	9.125	10.50	1.59	3.19	11	12.750	12.50	-	0.75
		F, N, P, G, C	6.25	9.125	10.50	1.983	3.19	11	12.750	12.50	-	0.75
	R	6.25	11.875	13.25	1.983	3.19	11	12.750	12.50	-	2.50	

33SV - 92SV Horizontal Mounting Option

- Consists of e-SV pump with base mounting foot and footed motor for horizontal installations.
- Unit depicted may not show actual pump configuration. Use for mounting location only.

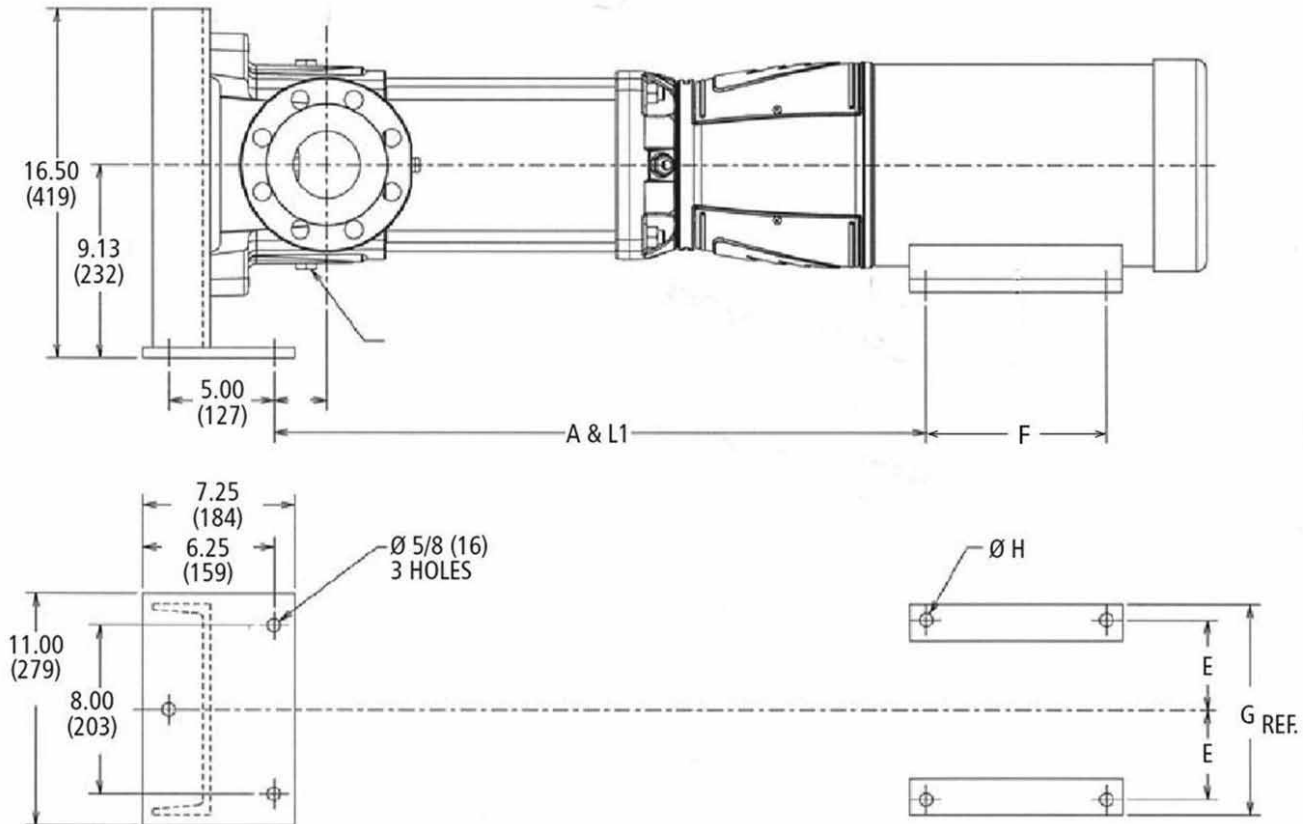

Series	Motor Frame	Flange	A	B	E	F	G	H - DIA.		
33SV	182TC	G, N	0.5	1.13	3.5	2.25	8.63	13/32		
	184TC					2.75				
	213TC					2.75				
	215TC		1.25		4.25	3.5	9.5	17/32		
	254TC		1.75		5	4.12	11.25			
	256TC				5	4.75	12.25			
	284TC		1.75		5.5	5.5	16	21/32		
	286TC		2.25		6.25	6				
	324TSC				7	5.63			18	
	326TSC		2.88		6.12	2.5	3.7	2.25	8.63	13/32
	364TSC		2.88		2.75					
	365TSC				2.75					
46/66/92SV	182TC	G, N	0.5	2.5	4.25		2.25	9.5	17/32	
	184TC						2.75			
	213TC						3.5			
	215TC		1.75		5		4.12	11.25	17/32	
	254TC				5		4.75	16.5		
	256TC		1.75		5.5		5.5	15.25		21/32
	284TC		2.25		6.25		6			
	286TC				7		5.63		17	
	324TSC		2.88		6.12		2.5	3.7	2.25	8.63
	326TSC		2.88		2.75					
	364TSC				2.75					
	365TSC		2.88		2.75	2.5		4.25	3.5	9.5
182TC	0.5	5		4.12	11.25					
184TC		5	4.75	16.5						
213TC	1.25	5.5	5.5	15.25	21/32					
215TC		1.75	6.25					6		
254TC	1.75		7					5.63	17	
256TC	2.25	6.12	2.5	3.7	2.25			8.63	13/32	
284TC		2.25			2.75					
286TC	2.75									
324TSC	2.88	2.75		2.5	4.25		3.5	9.5	17/32	
326TSC		2.88					5			4.12
364TSC	5						4.75			16.5
365TSC	2.88	5.5			5.5	15.25	21/32			
182TC		0.5			6.25			6		
184TC	1.25				7			5.63	17	

Commercial Water

125SV Horizontal Mounting Option

- Consists of e-SV pump with base mounting foot and footed motor for horizontal installations.
- Unit depicted may not show actual pump configuration. Use for mounting location only.

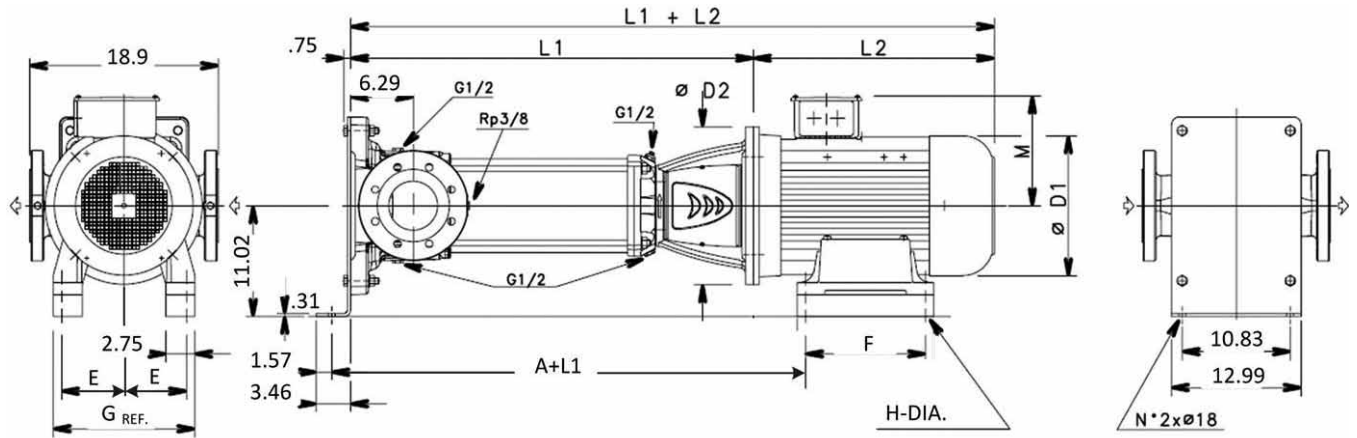

Series	Motor Frame	Flange	A	E	F	G (ref.)	H - Dia.
125SV	182TC	G, N	5.20	3.5	2.25	8.63	13/32
	184TC				2.75		
	213TC		5.82	4.25	2.75	9.5	17/32
	215TC				3.5		
	254TC		6.32	5	4.12	11.25	17/32
	256TC				5		
	284TC		6.32	5.5	4.75	12.25	17/32
	286TC				5.5		
	324TSC		6.82	6.25	5.25	16	21/32
	326TSC				6		
	364TSC		7.45	7	5.63	18	21/32
	365TSC				6.12		

Technical Data - Pump Hydraulics / Motor Sizing

1SV 2900 RPM

No. of Impellers	Maximum HP draw	Motor Selection using SF				Motor Selection 1.0 SF			Shutoff TDH (meters)	Shutoff TDH (feet)	Shutoff TDH (psi)	Shutoff TDH (bar)	Casing/Sleeve Pressure Rating (standard assembly)	Pump Flange Rating	R Configuration [Top/Bottom]	T Configuration [Oval]	
		Rated HP	NEMA Motor Frame		Rated HP	NEMA Motor Frame											
			ODP	TEFC		ODP	TEFC										
30	2.01	2.00	56C		2.00	56C		179	586	254	17.5	25 Bar (362 psi)	Class 250 / 300	Yes	No		
29	1.94							172	563	244	16.8						
28	1.87							167	548	237	16.3						
27	1.81							161	528	228	15.8						
26	1.74	1.50						1.50	1.50	155	508					220	15.2
25	1.67									149	489					212	14.6
24	1.61									143	469					203	14.0
23	1.54									137	450					195	13.4
22	1.46	1.00			1.00			1.00	133	435	188				13.0		
21	1.40								127	415	180				12.4		
20	1.33								121	395	171				11.8		
19	1.26								115	376	163				11.2		
18	1.20	0.75	0.75	0.75	109	356	154	10.6									
17	1.13				102	334	144	10.0									
16	1.07				97	317	137	9.4									
15	0.99				89	291	126	8.7									
14	0.93	0.50	0.50	0.50	83	272	118	8.1									
13	0.86				77	253	109	7.5									
12	0.80				71	233	101	7.0									
11	0.73				65	213	92	6.4									
10	0.66	0.50	0.50	0.50	59	194	84	5.8									
9	0.59				53	174	75	5.2									
8	0.53				47	155	67	4.6									
7	0.46				41	136	59	4.1									
6	0.39	0.50	0.50	0.50	36	116	50	3.5									
5	0.33				29	96	42	2.9									
4	0.26				24	78	34	2.3									
3	0.20				18	58	25	1.7									
2	0.13				12	39	17	1.2									

3SV 2900 RPM

No. of Impellers	Maximum HP draw	Motor Selection using SF				Motor Selection 1.0 SF			Shutoff TDH (meters)	Shutoff TDH (feet)	Shutoff TDH (psi)	Shutoff TDH (bar)	Casing/Sleeve Pressure Rating (standard assembly)	Pump Flange Rating	R Configuration [Top/Bottom]	T Configuration [Oval]					
		Rated HP	NEMA Motor Frame		Rated HP	NEMA Motor Frame															
			ODP	TEFC		ODP	TEFC														
30	3.26	3.00	182TC	184TC	5.00	184TC		227	743	322	22.2	25 Bar (362 psi)	Class 250 / 300	Yes	No						
29	3.11							212	695	301	20.7										
28	3.01							3.00	182TC	184TC	3.00					182TC	184TC	204	671	290	20.0
27	2.90																	197	647	280	19.3
26	2.79				190										623			270	18.6		
25	2.69				183										600			260	17.9		
24	2.58				2.00			56C	56C	2.00	56C				56C	175	575	249	17.2		
23	2.47															168	550	238	16.4		
22	2.36															160	526	228	15.7		
21	2.25															153	503	218	15.0		
20	2.15				1.50			56C	56C	1.50	56C				56C	146	479	207	14.3		
19	2.04															139	455	197	13.6		
18	1.93	131	430	186		12.8															
17	1.82	124	406	176		12.1															
16	1.72	1.00	56C	56C	1.00	56C	56C	116	381	165	11.4										
15	1.61							109	357	154	10.7										
14	1.50							102	334	145	10.0										
13	1.39							95	310	134	9.3										
12	1.31	0.75	56C	56C	0.75	56C	56C	87	285	123	8.5										
11	1.20							80	263	114	7.8										
10	1.09							73	238	103	7.1										
9	0.98							66	215	93	6.4										
8	0.87	0.50	56C	56C	0.50	56C	56C	58	191	82	5.7										
7	0.76							51	166	72	5.0										
6	0.64							44	143	62	4.3										
5	0.53							36	119	52	3.6										
4	0.43	0.50	56C	56C	0.50	56C	56C	29	96	41	2.9										
3	0.32							22	72	31	2.1										
2	0.21							15	48	21	1.4										

Technical Data - Pump Hydraulics / Motor Sizing

5SV 2900 RPM

No. of Impellers	Maximum HP draw	Motor Selection using SF			Motor Selection 1.0 SF			Shutoff TDH (meters)	Shutoff TDH (feet)	Shutoff TDH (psi)	Shutoff TDH (bar)	Casing/Sleeve Pressure Rating (standard assembly)	Pump Flange Rating	R Configuration [Top/Bottom]	T Configuration [Oval]	
		Rated HP	NEMA Motor Frame		Rated HP	NEMA Motor Frame										
			ODP	TEFC		ODP	TEFC									
27	5.02	5.00	184TC		5.00	184TC		204	669	290	20.0	25 Bar (362 psi)	Class 250 / 300		No	
26	4.83							196	644	279	19.2					
25	4.59							180	591	256	17.6					
24	4.41							173	567	245	16.9					
23	4.22							166	543	235	16.2					
22	4.04							158	520	225	15.5					
21	3.85							151	496	215	14.8					
20	3.67							144	472	204	14.1					
19	3.49							137	449	194	13.4					
18	3.30							130	425	184	12.7					
17	3.12	3.00	182TC	184TC	3.00	182TC	184TC	122	402	174	12.0				Yes	
16	2.93							115	378	164	11.3					
15	2.75							108	354	153	10.6					
14	2.57							101	331	143	9.9					
13	2.39							94	307	133	9.2					
12	2.20							86	283	123	8.5					
11	2.03							80	261	113	7.8					
10	1.84							72	237	103	7.1					
9	1.66							65	213	92	6.4					
8	1.47							58	190	82	5.7					
7	1.29	2.00	56C	56C	1.50	56C	56C	51	166	72	4.9				No	
6	1.11							43	142	61	4.2					
5	0.95							36	119	52	3.6					
4	0.76							29	95	41	2.8					
3	0.56							22	71	31	2.1					
2	0.38							15	48	21	1.4					

10SV 2900 RPM

No. of Impellers	Maximum HP draw	Motor Selection using SF			Motor Selection 1.0 SF			Shutoff TDH (meters)	Shutoff TDH (feet)	Shutoff TDH (psi)	Shutoff TDH (bar)	Casing/Sleeve Pressure Rating (standard assembly)	Pump Flange Rating	R Configuration [Top/Bottom]	T Configuration [Oval]										
		Rated HP	NEMA Motor Frame		Rated HP	NEMA Motor Frame																			
			ODP	TEFC		ODP	TEFC																		
20	9.55	10.00	215TC	254TC	10.00	215TC	254TC	228	749	324	22.4	25 Bar (362 psi)	Class 250 / 300		No										
19	9.07							217	712	308	21.2														
18	8.60							206	674	292	20.1														
17	8.12							7.50	213TC	215TC	7.50					213TC	215TC	194	637	276	19.0		Yes		
16	7.64																	183	599	259	17.9				
15	7.18																	171	562	243	16.8				
14	6.70																	160	525	227	15.7				
13	6.22																	149	488	211	14.5				
12	5.75																	137	450	195	13.4				
11	5.17																	123	405	175	12.1				
10	4.71	5.00	184TC	184TC	5.00	184TC	184TC							112	368			159	11.0		Yes				
9	4.24													101	331			143	9.9						
8	3.74													91	299			129	8.9						
7	3.27							80	261	113	7.8														
6	2.87							3.00	182TC	184TC	3.00			182TC	184TC	68	224	97	6.7				No		
5	2.39															57	187	81	5.6						
4	1.89															46	150	65	4.5						
3	1.45															34	112	49	3.3						
2	0.97															23	74	32	2.2						
1	0.47															11	37	16	1.1						

Technical Data - Pump Hydraulics / Motor Sizing

15SV 2900 RPM

No. of Impellers	Maximum HP draw	Motor Selection using SF			Motor Selection 1.0 SF			Shutoff TDH (meters)	Shutoff TDH (feet)	Shutoff TDH (psi)	Shutoff TDH (bar)	Casing/Sleeve Pressure Rating (standard assembly)	Pump Flange Rating	R Configuration [Top/Bottom]	T Configuration [Oval]							
		Rated HP	NEMA Motor Frame		Rated HP	NEMA Motor Frame																
			ODP	TEFC		ODP	TEFC															
15	15.11	15.00	254TC	256TC	15.00	254TC	256TC	210	688	298	20.5	25 Bar (362 psi)	Class 250 / 300	Yes	No							
14	14.11							196	642	278	19.2											
13	13.09							182	596	258	17.8											
12	12.08							168	551	238	16.4											
11	11.08	10.00	215TC	254TC	10.00	215TC	254TC	154	505	218	15.1				25 Bar (362 psi)	Class 250 / 300	Yes	Yes				
10	10.07							140	459	198	13.7											
9	9.22							125	411	178	12.3											
8	8.20							111	365	158	10.9											
7	7.16	7.50	213TC	215TC	7.50	213TC	215TC	98	320	139	9.6			25 Bar (362 psi)				Class 250 / 300	Yes	Yes		
6	6.14							84	274	119	8.2											
5	4.87							69	227	98	6.8											
4	3.90							55	182	79	5.4											
3	2.98	3.00	182TC	184TC	3.00	182TC	184TC	41	135	59	4.0						25 Bar (362 psi)			Class 250 / 300	Yes	Yes
2	2.01	2.00	56C		2.00	56C		27	90	39	2.7											
1	1.08	1.00			1.50			13	44	19	1.3											

22SV 2900 RPM

No. of Impellers	Maximum HP draw	Motor Selection using SF			Motor Selection 1.0 SF			Shutoff TDH (meters)	Shutoff TDH (feet)	Shutoff TDH (psi)	Shutoff TDH (bar)	Casing/Sleeve Pressure Rating (standard assembly)	Pump Flange Rating	R Configuration [Top/Bottom]	T Configuration [Oval]							
		Rated HP	NEMA Motor Frame		Rated HP	NEMA Motor Frame																
			ODP	TEFC		ODP	TEFC															
12	15.78	15.00	254TC	256TC	15.00	254TC	256TC	176	576	249	17.2	25 Bar (362 psi)	Class 250 / 300	Yes	No							
11	14.47							161	528	228	15.8											
10	13.37							147	483	209	14.4											
9	12.03							132	434	188	13.0											
8	10.70	10.00	215TC	254TC	10.00	215TC	254TC	118	386	167	11.5				25 Bar (362 psi)	Class 250 / 300	Yes	Yes				
7	9.36							103	338	146	10.1											
6	8.02							88	290	125	8.6											
5	6.54							72	238	103	7.1											
4	5.23	7.50	213TC	215TC	7.50	213TC	215TC	58	190	82	5.7			25 Bar (362 psi)				Class 250 / 300	Yes	Yes		
3	3.92							43	143	62	4.3											
2	2.61							29	95	41	2.8											
1	1.39							14	46	20	1.4											
3	3.92	5.00	184TC	184TC	3.00	182TC	184TC	29	95	41	2.8						25 Bar (362 psi)			Class 250 / 300	No	Yes
2	2.61	3.00	182TC	184TC	3.00	182TC	184TC	29	95	41	2.8											
1	1.39	1.50	56C		1.50	56C		14	46	20	1.4											

Technical Data - Pump Hydraulics / Motor Sizing

33SV 2900 RPM

No. of Impellers	Maximum HP draw	Motor Selection using SF			Motor Selection 1.0 SF			Shutoff TDH (meters)	Shutoff TDH (feet)	Shutoff TDH (psi)	Shutoff TDH (bar)	Casing/Sleeve Pressure Rating (standard assembly)	Pump Flange Rating	Stages Requiring Thrust Balancing Piston
		Rated HP	NEMA Motor Frame		Rated HP	NEMA Motor Frame								
			ODP	TEFC		ODP	TEFC							
10	32.0	30	286TC		40	324TSC	326TSC	233	766	332	22.9	25 Bar (362 psi)	Class 250 / 300	Thrust Piston Required
10/1	30.5							229	750	325	22.4			
10/2	29.0							223	732	317	21.8			
9	28.8	25	284TC	286TC	30	286TC	210	690	299	20.6				
9/1	27.3						204	668	289	19.9				
9/2	25.8						199	652	282	19.5				
8	25.6						187	612	265	18.3				
8/1	24.1						180	592	256	17.7				
8/2	22.6						174	570	247	17.0				
7	22.4	20	254TC	284TC	25	284TC	163	534	231	15.9				
7/1	20.9						157	514	222	15.3				
7/2	19.4						150	493	213	14.7				
6	19.2						140	458	198	13.7				
6/1	17.7	20	254TC	284TC	20	254TC	133	437	189	13.0				
6/2	16.2						127	416	180	12.4				
5	16.0						116	380	164	11.3				
5/1	14.6	15	254TC	256TC	15	254TC	111	363	157	10.8				
5/2	13.1						104	342	148	10.2				
4	12.9						94	308	133	9.2				
4/1	11.4	10	215TC	254TC	10	215TC	87	287	124	8.6				
4/2	9.9						81	267	116	8.0				
3	9.7						70	230	100	6.9				
3/1	8.2	7.5	213TC	215TC	7.5	213TC	65	212	92	6.3				
3/2	6.6						58	190	82	5.7				
2	6						46	152	66	4.5				
2/1	4.9	5	184TC		5	184TC		41	133	58	4.0			
2/2	3.5							34	113	49	3.4			
1	3.2							23	76	33	2.3			

Technical Data - Pump Hydraulics / Motor Sizing

46SV 2900 RPM

No. of Impellers	Maximum HP draw	Motor Selection using SF				Motor Selection 1.0 SF			Shutoff TDH (meters)	Shutoff TDH (feet)	Shutoff TDH (psi)	Shutoff TDH (bar)	Casing/Sleeve Pressure Rating (standard assembly)	Pump Flange Rating	Stages Requiring Thrust Balancing Piston
		Rated HP	NEMA Motor Frame		Rated HP	NEMA Motor Frame									
			ODP	TEFC		ODP	TEFC								
10	45.8	40	324TSC	326TSC	50	324TSC	326TSC	256	839	363	25.0	25 Bar (362 psi)	Class 250 / 300	Thrust Piston Required	
10/1	44.3							251	825	357	24.6				
10/2	42.4							249	818	354	24.4				
9	41.3							234	767	332	22.9				
9/1	39.6							230	753	326	22.5				
9/2	37.8							224	735	318	21.9				
8	36.7							208	684	296	20.4				
8/1	35.0	30	286TC	40	286TC	286TC	286TC	203	666	288	19.9				
8/2	33.3							198	648	280	19.3				
7	32.0							184	605	262	18.1				
7/1	30.3							179	588	254	17.5				
7/2	28.6							173	566	245	16.9				
6	27.5							158	520	225	15.5				
6/1	25.7							153	501	217	14.9				
6/2	24.0	148	486	210	14.5										
5	22.9	25	284TC	286TC	30	286TC	286TC	131	430	186	12.8				
5/1	21.2							126	413	179	12.3				
5/2	19.4							121	398	172	11.9				
4	18.4							105	345	149	10.3				
4/1	16.9							99	326	141	9.7				
4/2	14.9							95	311	135	9.3				
3	13.8							78	255	110	7.6				
3/1	12.1	20	254TC	284TC	20	254TC	284TC	73	239	103	7.1				
3/2	10.3							66	218	94	6.5				
2	9.1							53	175	76	5.2				
2/1	7.4							47	153	66	4.6				
2/2	5.6							41	135	58	4.0				
1	4.6							26	85	37	2.5				
								26	85	37	2.5				

66SV 2900 RPM

No. of Impellers	Maximum HP draw	Motor Selection using SF				Motor Selection 1.0 SF			Shutoff TDH (meters)	Shutoff TDH (feet)	Shutoff TDH (psi)	Shutoff TDH (bar)	Casing/Sleeve Pressure Rating (standard assembly)	Pump Flange Rating	Stages Requiring Thrust Balancing Piston
		Rated HP	NEMA Motor Frame		Rated HP	NEMA Motor Frame									
			ODP	TEFC		ODP	TEFC								
6	41.0	40	324TSC	326TSC	50	324TSC	326TSC	177	582	252	17.4	25 Bar (362 psi)	Class 250 / 300	Thrust Piston Required	
6/1	39.1							169	556	241	16.6				
6/2	37.3							165	540	234	16.1				
5	34.0	30	286TC	40	286TC	286TC	286TC	146	478	207	14.3				
5/1	32.3							141	461	200	13.8				
5/2	30.5							135	443	192	13.2				
4	27.1							117	383	166	11.4				
4/1	25.3							111	365	158	10.9				
4/2	23.7							107	350	151	10.4				
3	20.5							89	291	126	8.7				
3/1	18.7	25	284TC	284TC	20	254TC	284TC	82	270	117	8.1				
3/2	16.9							77	252	109	7.5				
2	13.6							59	193	84	5.8				
2/1	11.9							53	175	76	5.2				
2/2	10.1							48	157	68	4.7				
1	6.8							29	96	42	2.9				
								29	96	42	2.9				

Commercial Water

Technical Data - Pump Hydraulics / Motor Sizing

92SV 2900 RPM

No. of Impellers	Maximum HP draw	Motor Selection using SF			Motor Selection 1.0 SF			Shutoff TDH (meters)	Shutoff TDH (feet)	Shutoff TDH (psi)	Shutoff TDH (bar)	Casing/Sleeve Pressure Rating (standard assembly)	Pump Flange Rating	Stages Requiring Thrust Balancing Piston		
		Rated HP	NEMA Motor Frame		Rated HP	NEMA Motor Frame										
			ODP	TEFC		ODP	TEFC									
6	54.0	50	324TSC	326TSC	60	364TSC	364TSC	189	619	268	18.5	25 Bar (362 psi)	Class 250 / 300	Piston Required		
6/1	51.7							183	600	260	17.9					
6/2	49.4							177	581	251	17.3					
5	45.0	50			324TSC	326TSC	40	324TSC	326TSC	158	518				224	15.5
5/1	42.1									153	501				217	14.9
5/2	40.0									147	483				209	14.4
4	35.5	40	324TSC	326TSC	40	324TSC	326TSC	126	413	179	12.3					
4/1	33.2							120	394	171	11.8					
4/2	31.0							117	385	167	11.5					
3	26.6	25	284TC	286TC	30	286TC		96	315	136	9.4					
3/1	24.3					90	296	128	8.8							
3/2	22.0					86	283	122	8.4							
2	17.8	20	254TC	284TC	20	254TC	284TC	63	208	90	6.2					
2/1	15.5					58	189	82	5.6							
2/2	13.1					53	174	75	5.2							
1	9.0	15	254TC	256TC	15	254TC	256TC	53	174	75	5.2					
1/1	6.8					10	215TC	254TC	10	215TC	254TC	30	100	43	3.0	
1/1	6.8	7.5	213TC	215TC	7.5	213TC	215TC	26	86	37	2.6					

125SV 2900 RPM

No. of Impellers	Maximum HP draw	Motor Selection using SF			Motor Selection 1.0 SF			Shutoff TDH (meters)	Shutoff TDH (feet)	Shutoff TDH (psi)	Shutoff TDH (bar)	Casing/Sleeve Pressure Rating (standard assembly)	Pump Flange Rating	Stages Requiring Thrust Balancing Piston
		Rated HP	NEMA Motor Frame		Rated HP	NEMA Motor Frame								
			ODP	TEFC		ODP	TEFC							
8/1B	68.26	60.00	364TSC	365TSC	Contact Factory			201	659	285	19.7	25 Bar (362 psi)	Class 250 / 300	Thrust Piston Required
7/3B	56.61	50.00	324TSC	326TSC	60.00	364TSC	365TSC	168	551	239	16.4			
6/2B	49.36				50.00	324TSC	326TSC	146	479	207	14.3			
5/0C	43.61				40.00	324TSC	326TSC	128	420	182	12.5			
4/4A	32.62	30.00	286TC	286TC	40.00	324TSC	326TSC	95	312	135	9.3			
3/2A	24.87	25.00	284TC	286TC	30.00	286TC	286TC	73	240	104	7.1			
2/2A	18.65	20.00	254TC	284TC	20.00	254TC	284TC	49	161	70	4.8			
1/0C	9.57	10.00	215TC	254TC	10.00	215TC	254TC	27	89	38	2.6			

Technical Data - Pump Hydraulics / Motor Sizing

1SV 1450 RPM

No. of Impellers	Maximum HP draw	Motor Selection using SF			Motor Selection 1.0 SF			Shutoff TDH (meters)	Shutoff TDH (feet)	Shutoff TDH (psi)	Shutoff TDH (bar)	Casing/ Sleeve Pressure Rating (standard assembly)	Pump Flange Rating	R Configuration [Top/ Bottom]	T Configuration [Oval]
		Rated HP	NEMA Motor Frame		Rated HP	NEMA Motor Frame									
			ODP	TEFC		ODP	TEFC								
30	0.25	0.50	56C	0.50	56C	44	143	62	4.3	25 Bar (362 psi)	Class 250 / 300	Yes	Yes		
29	0.24					42	139	60	4.1						
28	0.24					41	134	58	4.0						
27	0.23					39	129	56	3.9						
26	0.22					38	124	54	3.7						
25	0.21					36	119	52	3.6						
24	0.20					35	115	50	3.4						
23	0.19					34	112	48	3.3						
22	0.18					32	105	45	3.1						
21	0.18					31	102	44	3.0						
20	0.17					29	95	41	2.8						
19	0.16					28	92	40	2.7						
18	0.15					26	85	37	2.5						
17	0.14					25	82	35	2.4						
16	0.13					23	75	33	2.3						
15	0.12					22	72	31	2.2						
14	0.12					20	66	28	2.0						
13	0.11					19	62	27	1.9						
12	0.10					17	56	24	1.7						
11	0.09					16	52	23	1.6						
10	0.08					15	49	21	1.5						
9	0.08					13	43	18	1.3						
8	0.07					12	39	17	1.2						
7	0.06					10	33	14	1.0						
6	0.05					9	30	13	0.9						
5	0.04					7	23	10	0.7						
4	0.03					6	20	9	0.6						
3	0.02					4	13	6	0.4						
2	0.02	3	10	4	0.3										

3SV 1450 RPM

No. of Impellers	Maximum HP draw	Motor Selection using SF			Motor Selection 1.0 SF			Shutoff TDH (meters)	Shutoff TDH (feet)	Shutoff TDH (psi)	Shutoff TDH (bar)	Casing/ Sleeve Pressure Rating (standard assembly)	Pump Flange Rating	R Configuration [Top/ Bottom]	T Configuration [Oval]
		Rated HP	NEMA Motor Frame		Rated HP	NEMA Motor Frame									
			ODP	TEFC		ODP	TEFC								
30	0.45	0.50	56C	0.50	56C	54	177	77	5.3	25 Bar (362 psi)	Class 250 / 300	Yes	Yes		
29	0.43					52	171	74	5.1						
28	0.42					51	167	72	5.0						
27	0.40					49	161	70	4.8						
26	0.39					47	154	67	4.6						
25	0.37					45	148	64	4.4						
24	0.36					43	141	61	4.2						
23	0.34					42	138	60	4.1						
22	0.33					40	131	57	3.9						
21	0.32					38	125	54	3.7						
20	0.30					36	118	51	3.5						
19	0.27					33	108	47	3.2						
18	0.25					31	102	44	3.0						
17	0.24					29	95	41	2.8						
16	0.23					27	89	38	2.6						
15	0.21					26	85	37	2.5						
14	0.21					25	82	35	2.4						
13	0.20					23	75	33	2.3						
12	0.19					22	72	31	2.2						
11	0.18					20	66	28	2.0						
10	0.15					18	59	26	1.8						
9	0.14					16	52	23	1.6						
8	0.12					14	46	20	1.4						
7	0.10					13	43	18	1.3						
6	0.09					11	36	16	1.1						
5	0.07					9	30	13	0.9						
4	0.06					7	23	10	0.7						
3	0.04					5	16	7	0.5						
2	0.03	4	13	6	0.4										

Technical Data - Pump Hydraulics / Motor Sizing

5SV 1450 RPM

No. of Impellers	Maximum HP draw	Motor Selection using SF			Motor Selection 1.0 SF			Shutoff TDH (meters)	Shutoff TDH (feet)	Shutoff TDH (psi)	Shutoff TDH (bar)	Casing/ Sleeve Pressure Rating (standard assembly)	Pump Flange Rating	R Configuration [Top/ Bottom]	T Configuration [Oval]
		Rated HP	NEMA Motor Frame		Rated HP	NEMA Motor Frame									
			ODP	TEFC		ODP	TEFC								
27	0.60	0.50	56C		0.75	56C		49	161	70	4.8	25 Bar (362 psi)	Class 250 / 300	Yes	Yes
26	0.59							48	157	68	4.7				
25	0.58							45	148	64	4.4				
24	0.55							43	141	61	4.2				
23	0.54							41	135	58	4.0				
22	0.51							40	131	57	3.9				
21	0.50							38	125	54	3.7				
20	0.48							36	118	51	3.5				
19	0.46							34	112	48	3.3				
18	0.43							32	105	45	3.1				
17	0.40							31	102	44	3.0				
16	0.38							29	95	41	2.8				
15	0.35							27	89	38	2.6				
14	0.32							25	82	35	2.4				
13	0.30				23			75	33	2.3					
12	0.27				22			72	31	2.2					
11	0.25				20			66	28	2.0					
10	0.24				18			59	26	1.8					
9	0.23				16			52	23	1.6					
8	0.21				14			46	20	1.4					
7	0.19				13			43	18	1.3					
6	0.13				11			36	16	1.1					
5	0.12				9			30	13	0.9					
4	0.11				7			23	10	0.7					
3	0.07				5			16	7	0.5					
2	0.05				4			13	6	0.4					

10SV 1450 RPM

No. of Impellers	Maximum HP draw	Motor Selection using SF			Motor Selection 1.0 SF			Shutoff TDH (meters)	Shutoff TDH (feet)	Shutoff TDH (psi)	Shutoff TDH (bar)	Casing/ Sleeve Pressure Rating (standard assembly)	Pump Flange Rating	R Configuration [Top/ Bottom]	T Configuration [Oval]	
		Rated HP	NEMA Motor Frame		Rated HP	NEMA Motor Frame										
			ODP	TEFC		ODP	TEFC									
20	1.22	1.50	56C		1.50	56C		60	197	85	5.9	25 Bar (362 psi)	Class 250 / 300	Yes	Yes	
19	1.15	1.00						1.00	54	177	77					5.3
18	1.09								51	167	72					5.0
17	1.03								49	161	70					4.8
16	0.97								47	154	67					4.6
15	0.90								43	141	61					4.2
14	0.84	0.75						1.00	40	131	57					3.9
13	0.79								37	121	53					3.6
12	0.72								34	112	48					3.3
11	0.67								31	102	44					3.0
10	0.59				28				92	40	2.7					
9	0.54	0.50			0.75			25	82	35	2.4					
8	0.47							23	75	33	2.3					
7	0.42							20	66	28	2.0					
6	0.36							17	56	24	1.7					
5	0.30							14	46	20	1.4					
4	0.24							11	36	16	1.1					
3	0.17							9	30	13	0.9					
2	0.12							6	20	9	0.6					
1	0.05							3	10	4	0.3					

Technical Data - Pump Hydraulics / Motor Sizing

15SV 1450 RPM

No. of Impellers	Maximum HP draw	Motor Selection using SF		Motor Selection 1.0 SF			Shutoff TDH (meters)	Shutoff TDH (feet)	Shutoff TDH (psi)	Shutoff TDH (bar)	Casing/ Sleeve Pressure Rating (standard assembly)	Pump Flange Rating	R Configuration [Top/ Bottom]	T Configuration [Oval]	
		Rated HP	NEMA Motor Frame		Rated HP	NEMA Motor Frame									
			ODP	TEFC		ODP									TEFC
15	1.88	2.00	56C	56C	2.00	56C	52	171	74	5.1	25 Bar (362 psi)	Class 250 / 300	Yes	Yes	
14	1.74						49	161	70	4.8					
13	1.61						45	148	64	4.4					
12	1.48	1.50			42		138	60	4.1						
11	1.34				38		125	54	3.7						
10	1.21				35		115	50	3.4						
9	1.21	1.00			31		102	44	3.0						
8	1.07				28		92	40	2.7						
7	0.94				24		79	34	2.3						
6	0.80	0.75			21		69	30	2.1						
5	0.67				17		56	24	1.7						
4	0.54				14		46	20	1.4						
3	0.40	0.50			10		33	14	1.0						
2	0.27				7		23	10	0.7						
1	0.13				4		13	6	0.4						

22SV 1450 RPM

No. of Impellers	Maximum HP draw	Motor Selection using SF		Motor Selection 1.0 SF			Shutoff TDH (meters)	Shutoff TDH (feet)	Shutoff TDH (psi)	Shutoff TDH (bar)	Casing/ Sleeve Pressure Rating (standard assembly)	Pump Flange Rating	R Configuration [Top/ Bottom]	T Configuration [Oval]	
		Rated HP	NEMA Motor Frame		Rated HP	NEMA Motor Frame									
			ODP	TEFC		ODP									TEFC
12	1.97	2.00	56C	56C	2.00	56C	43	141	61	4.2	25 Bar (362 psi)	Class 250 / 300	Yes	Yes	
11	1.74						40	131	57	3.9					
10	1.61						37	121	53	3.6					
9	1.48	1.50			33		108	47	3.2						
8	1.34				29		95	41	2.8						
7	1.21				26		85	37	2.5						
6	0.94	1.00			22		72	31	2.2						
5	0.80				18		59	26	1.8						
4	0.67				15		49	21	1.5						
3	0.54	0.50			11		36	16	1.1						
2	0.27				7		23	10	0.7						
1	0.13				4		13	6	0.4						

Technical Data - Pump Hydraulics / Motor Sizing

33SV 1450 RPM

No. of Impellers	Maximum HP draw	Motor Selection using SF			Motor Selection 1.0 SF			Shutoff TDH (meters)	Shutoff TDH (feet)	Shutoff TDH (psi)	Shutoff TDH (bar)	Casing/Sleeve Pressure Rating (standard assembly)	Pump Flange Rating	Stages Requiring Thrust Balancing Piston									
		Rated HP	NEMA Motor Frame		Rated HP	NEMA Motor Frame																	
			ODP	TEFC		ODP	TEFC																
10	3.9	5.0	184TC	184TC	5.0	184TC	184TC	59	201	84	5.8	25 Bar (362 psi)	Class 125 / 150										
10/1	3.8							57	194	81	5.6												
10/2	3.7							56	191	80	5.5												
9	3.5	3.0	182TC	184TC				5.0	184TC	184TC	53				181	75	5.2						
9/1	3.4										51				174	72	5.0						
9/2	3.3										50				170	71	4.9						
8	3.1										47				160	67	4.6						
8/1	3.0										3.0				182TC	184TC	3.0	182TC	184TC	46	157	65	4.5
8/2	2.9																			44	150	62	4.3
7	2.7																			41	140	58	4.0
7/1	2.6				40	136	57													3.9			
7/2	2.5				38	130	54													3.7			
6	2.3				35	119	50													3.4			
6/1	2.2	34	116	48	3.3																		
6/2	2.1	32	109	45	3.1																		
5	1.9	29	99	41	2.8																		
5/1	1.8	28	95	40	2.7																		
5/2	1.7	26	89	37	2.5																		
4	1.5	24	82	34	2.3																		
4/1	1.4	22	75	31	2.2																		
4/2	1.3	20	68	28	2.0																		
3	1.2	18	61	26	1.8																		
3/1	1.1	16	55	23	1.6																		
3/2	0.9	15	51	21	1.5																		
2	0.8	12	41	17	1.2																		
2/1	0.7	10	34	14	1.0																		
2/2	0.6	9	30	12	0.9																		
1	0.4	6	20	9	0.6																		

Technical Data - Pump Hydraulics / Motor Sizing

46SV 1450 RPM

No. of Impellers	Maximum HP draw	Motor Selection using SF			Motor Selection 1.0 SF			Shutoff TDH (meters)	Shutoff TDH (feet)	Shutoff TDH (psi)	Shutoff TDH (bar)	Casing/Sleeve Pressure Rating (standard assembly)	Pump Flange Rating	Stages Requiring Thrust Balancing Piston						
		Rated HP	NEMA Motor Frame		Rated HP	NEMA Motor Frame														
			ODP	TEFC		ODP	TEFC													
10	6.0	7.5	213TC	215TC	7.5	213TC	215TC	68	222	96	6.6	25 Bar (362 psi)	Class 125 / 150							
10/1	5.8							66	218	94	6.5									
10/2	5.5							63	215	89	6.2									
9	5.2	5.0	184TC	184TC				5.0	184TC	184TC	59				201	84	5.8			
9/1	5.1										58				198	82	5.7			
9/2	5.0										57				194	81	5.6			
8	4.6				53	181	75				5.2									
8/1	4.5				52	177	74				5.1									
8/2	4.4				50	170	71				4.9									
7	4.1				46	157	65				4.5									
7/1	4.0				45	153	64				4.4									
7/2	3.9				44	150	62				4.3									
6	3.5				3.0	182TC	184TC				3.0				182TC	184TC	40	136	57	3.9
6/1	3.4																38	130	54	3.7
6/2	3.2																37	126	53	3.6
5	2.9	33	112	47				3.2												
5/1	2.8	32	109	45				3.1												
5/2	2.6	30	102	43				2.9												
4	2.3	26	89	37				2.5												
4/1	2.2	25	85	35				2.4												
4/2	2.1	24	82	34				2.3												
3	1.7	20	68	28				2.0												
3/1	1.6	18	61	26				1.8												
3/2	1.5	17	58	24				1.7												
2	1.2	13	44	18				1.3												
2/1	1.0	12	41	17				1.2												
2/2	0.9	10	34	14				1.0												
1	0.6	7	24	10				0.7												

66SV 1450 RPM

No. of Impellers	Maximum HP draw	Motor Selection using SF			Motor Selection 1.0 SF			Shutoff TDH (meters)	Shutoff TDH (feet)	Shutoff TDH (psi)	Shutoff TDH (bar)	Casing/Sleeve Pressure Rating (standard assembly)	Pump Flange Rating	Stages Requiring Thrust Balancing Piston			
		Rated HP	NEMA Motor Frame		Rated HP	NEMA Motor Frame											
			ODP	TEFC		ODP	TEFC										
6	5.1	5.0	184TC	184TC	7.5	213TC	215TC	43	147	61	4.2	25 Bar (362 psi)	Class 125 / 150				
6/1	4.9				42	143	60	4.1									
6/2	4.7				40	136	57	3.9									
5	4.2				5.0	184TC	184TC	5.0	184TC	184TC	36				123	51	3.5
5/1	4.0										34				116	48	3.3
5/2	3.9										33				112	47	3.2
4	3.4	29	99	41							2.8						
4/1	3.2	27	92	38							2.6						
4/2	3.0	26	89	37							2.5						
3	2.5	3.0	182TC	184TC	3.0	182TC	184TC	21	72	30	2.1						
3/1	2.3							20	68	28	2.0						
3/2	2.2							19	65	27	1.9						
2	1.7							14	48	20	1.4						
2/1	1.5							13	44	18	1.3						
2/2	1.3							12	41	17	1.2						
1	0.9							7	24	10	0.7						

Commercial Water

Technical Data - Pump Hydraulics / Motor Sizing

92SV 1450 RPM

No. of Impellers	Maximum HP draw	Motor Selection using SF			Motor Selection 1.0 SF			Shutoff TDH (meters)	Shutoff TDH (feet)	Shutoff TDH (psi)	Shutoff TDH (bar)	Casing/Sleeve Pressure Rating (standard assembly)	Pump Flange Rating	Stages Requiring Thrust Balancing Piston
		Rated HP	NEMA Motor Frame		Rated HP	NEMA Motor Frame								
			ODP	TEFC		ODP	TEFC							
6	6.6	7.5	213TC	213TC	7.5	213TC	213TC	46	150	65	4.5	25 Bar (362 psi)	Class 125 / 150	
6/1	6.3							45	146	63	4.4			
6/2	6.0							43	142	61	4.2			
5	5.5	5	184TC	184TC	5.00	184TC	184TC	41	134	58	4.0			
5/1	5.2							38	130	54	3.7			
5/2	4.9							37	126	53	3.6			
4	4.4							32	109	45	3.1			
4/1	4.1							30	102	43	2.9			
4/2	3.8							29	99	41	2.8			
3	3.3	3.0	182TC	184TC	3.00	182TC	184TC	24	82	34	2.3			
3/1	3.0							22	75	31	2.2			
3/2	2.7							21	72	30	2.1			
2	2.2							16	55	23	1.6			
2/1	1.9							15	51	21	1.5			
2/2	1.7							13	44	18	1.3			
1	1.1							8	27	11	0.8			
1/1	0.9	7	24	10	0.7									

125SV 1450 RPM

No. of Impellers	Maximum HP draw	Motor Selection using SF			Motor Selection 1.0 SF			Shutoff TDH (meters)	Shutoff TDH (feet)	Shutoff TDH (psi)	Shutoff TDH (bar)	Casing/Sleeve Pressure Rating (standard assembly)	Pump Flange Rating	Stages Requiring Thrust Balancing Piston
		Rated HP	NEMA Motor Frame		Rated HP	NEMA Motor Frame								
			ODP	TEFC		ODP	TEFC							
8/0C	9.05	10.00	215TC	254TC	10.00	215TC	254TC	54	177	77	5.3	25 Bar (362 psi)	Class 125 / 150	Thrust Piston Required
7/0C	8.18	7.50	213TC	215TC				47	154	67	4.6			
6/0C	7.02				5.00	184TC		7.50	213TC	215TC	40			
5/0C	5.85	34	112	48							3.3			
4/0C	4.68	27	89	38				2.6						
3/0C	3.51	3.00	182TC	184TC	5.00	184TC		20	66	28	2.0			
2/0C	2.48							14	46	20	1.4			
1/0C	1.24							7	23	10	0.7			

Technical Data - Water Property Chart

Temp °F	Temp °C	Specific Volume (Cubic ft/lb)	Specific Gravity			Weight (lb/cubic ft)	Vapor Pressure (psi Abs)
			@ 39.2°F	@ 60°F	@ 68°F		
32	0.0	0.01602	1.000	1.001	1.002	62.42	0.088
35	1.7	0.01602	1.000	1.001	1.002	62.42	0.100
40	4.4	0.01602	1.000	1.001	1.002	62.42	0.122
50	10.0	0.01603	0.999	1.001	1.002	62.38	0.178
60	15.6	0.01604	0.999	1.000	1.001	62.34	0.256
70	21.1	0.01606	0.998	0.999	1.000	62.27	0.363
80	26.7	0.01608	0.996	0.998	0.999	62.19	0.507
90	32.2	0.0161	0.995	0.996	0.997	62.11	0.698
100	37.8	0.01613	0.993	0.994	0.995	62.00	0.949
120	48.9	0.0162	0.989	0.990	0.991	61.73	1.692
140	60.0	0.01629	0.983	0.985	0.986	61.39	2.889
160	71.1	0.01639	0.977	0.979	0.979	61.01	4.741
180	82.2	0.01651	0.970	0.972	0.973	60.57	7.510
200	93.3	0.01663	0.963	0.964	0.966	60.13	11.526
212	100.0	0.01672	0.958	0.959	0.960	59.81	14.696
220	104.4	0.01677	0.955	0.956	0.957	59.63	17.186
240	115.6	0.01692	0.947	0.948	0.949	59.10	24.97
260	126.7	0.01709	0.938	0.939	0.940	58.51	35.43
280	137.8	0.01726	0.928	0.929	0.930	58.00	49.20
300	148.9	0.01745	0.918	0.919	0.920	57.31	67.01
320	160.0	0.01756	0.908	0.909	0.910	56.66	89.66
340	171.1	0.01787	0.896	0.898	0.899	55.96	118.01
360	182.2	0.01811	0.885	0.886	0.887	55.22	153.04
380	193.3	0.01836	0.873	0.874	0.875	54.47	195.77
400	204.4	0.01864	0.859	0.860	0.862	53.65	247.31
420	215.6	0.01894	0.846	0.847	0.848	52.80	308.83
440	226.7	0.01926	0.832	0.833	0.834	51.92	381.59
460	237.8	0.0196	0.817	0.818	0.819	51.02	466.9
480	248.9	0.02	0.801	0.802	0.803	50.00	566.1
500	260.0	0.0204	0.785	0.786	0.787	49.02	680.8
520	271.1	0.0209	0.765	0.766	0.767	47.85	812.4
540	282.2	0.0215	0.746	0.747	0.748	46.51	962.5
560	293.3	0.0221	0.726	0.727	0.728	45.30	1133.1
580	304.4	0.0228	0.703	0.704	0.704	43.90	1325.8
600	315.6	0.0236	0.678	0.679	0.680	42.30	1542.9
620	326.7	0.0247	0.649	0.650	0.650	40.50	1786.6
640	337.8	0.026	0.617	0.618	0.618	38.50	2059.7
660	348.9	0.0278	0.577	0.577	0.578	36.00	2365.4
680	360.0	0.0305	0.525	0.526	0.527	32.80	2708.1
700	371.1	0.0369	0.434	0.435	0.435	27.10	3093.7

Commercial Water

Technical Data - NPSH

NPSH

The minimum operating values that can be reached at the pump suction end are limited by the onset of cavitation.

Cavitation is the formation of vapor-filled cavities within liquids where the pressure is locally reduced to a critical value, or where the local pressure is equal to, or just below the vapor pressure of the liquid.

The vapor-filled cavities flow with the current and when they reach a higher pressure area the vapor contained in the cavities condenses. The cavities collide, generating pressure waves that are transmitted to the walls. These, being subjected to stress cycles, gradually become deformed and yield due to fatigue. This phenomenon, characterized by a metallic noise produced by the hammering on the pipe walls, is called incipient cavitation.

The damage caused by cavitation may be magnified by electrochemical corrosion and a local rise in temperature due to the plastic deformation of the walls. The materials that offer the highest resistance to heat and corrosion are alloy steels, especially austenitic steel. The conditions that trigger cavitation may be assessed by calculating the total net suction head, referred to in technical literature with the acronym NPSH (Net Positive Suction Head).

The NPSH represents the total energy (expressed in feet) of the liquid measured at suction under conditions of incipient cavitation, excluding the vapor pressure (expressed in feet) that the liquid has at the pump inlet.

To find the static height (h_z) at which to install the machine under safe conditions, the following formula must be verified:

$$h_p + h_z \geq (\text{NPSHr} + 2 \text{ ft}) + h_f + h_{pv}$$

where:

h_p is the absolute pressure applied to the free liquid surface in the suction tank, expressed in feet of liquid; h_p is the quotient between the barometric pressure and the specific weight of the liquid.

h_z is the suction lift between the pump axis and the free liquid surface in the suction tank, expressed in feet; h_z is negative when the liquid level is lower than the pump axis.

h_f is the flow resistance in the suction line and its accessories, such as: fittings, foot valve, gate valve, elbows, etc.

h_{pv} is the vapor pressure of the liquid at the operating temperature, expressed in feet of the liquid. h_{pv} is the quotient between the P_v vapor pressure and the liquid's specific weight.

0.5 is the safety factor.

The maximum possible suction head for installation depends on the value of the atmospheric pressure (i.e. the elevation above sea level at which the pump is installed) and the temperature of the liquid.

To help the user, with reference to water temperature (40°F) and to the elevation above sea level, the following tables show the drop in hydraulic pressure head in relation to the elevation above sea level, and the suction loss in relation to temperature.

Water Temperature (°F)	68	104	140	176	194	230	248
Suction Loss (ft)	-7	2.3	6.6	16.4	24.3	50.5	70.5

Elevation Above Sea Level (ft)	1600	3300	4900	6500	8200	9800
Suction Loss (ft)	1.8	3.6	5.4	7.2	9.0	10.8

To reduce it to a minimum, especially in cases of high suction head (over 13 - 16 feet) or within the operating limits with high flow rates, we recommend using a suction line having a larger diameter than that of the pump's suction port. It is always a good idea to position the pump as close as possible to the liquid to be pumped.

Technical Data - Compatibility Chart for Materials in Contact with Most Commonly Used Liquids

Liquid	Concentration (%)	Temperature Min/Max °F	Specific Weight (lb/in ³)	SV 2, 4, 8, 16		SV 33, 46, 66, 92		Recommended Seal	Elastomers
				304	316	CI/316	316		
Water	100	23/248		•	•	•	•	Q ₁ BEGG	E
Deionized, demineralized or distilled water	100	-13/230		•	•	•	•	Q ₁ BEGG	E
Water and oil emulsion	any	23/194		•	•	•	•	Q ₁ BVGG	V
Acetic acid (•)	80	14/158	.038	•	•	•	•	Q ₁ BEGG	E
Citric acid	5	14/158	.056	•	•	•	•	Q ₁ BEGG	E
Hydrochloric acid	2	23/77	.043		•		•	Q ₁ Q ₁ VGG	V
Phosphoric acid	10	23/86	.048		•		•	Q ₁ BEGG	E
Nitric acid (•)	50	23/86	.053	•	•	•	•	Q ₁ Q ₁ VGG	V
Sulphuric acid (•)	2	14/77	.066		•		•	Q ₁ BVGG	V
Tannic acid	20	32/122			•		•	Q ₁ BEGG	E
Tartaric acid	50	14/77	.063	•	•	•	•	Q ₁ Q ₁ VGG	V
Uric acid	80	14/176	.068	•	•	•	•	Q ₁ BEGG	E
Benzoic acid	70	32/158	.047	•	•	•	•	Q ₁ BVGG	V
Boric acid	Saturated	14/194	.052	•	•	•	•	Q ₁ Q ₁ VGG	V
Formic acid (•)	5	5/77	.044	•	•	•	•	Q ₁ BEGG	E
Ethyl alcohol (•)	100	23/104	.029	•	•	•	•	Q ₁ BEGG	E
Methyl alcohol (•)	100	23/104	.029	•	•	•	•	Q ₁ BEGG	E
Propyl alcohol (•)	100	23/176	.029	•	•	•	•	Q ₁ BEGG	E
Butyl alcohol	100	23/176	.030	•	•	•	•	Q ₁ BVGG	V
Denatured alcohol (•)	100	23/158	.030	•	•	•	•	Q ₁ BEGG	E
Ammonia in water (•)	25	-4/122	.038	•	•	•	•	Q ₁ BEGG	E
Chloroform		14/86	.053	•	•	•	•	Q ₁ BVGG	V
Caustic soda	25	32/158	.077	•	•	•	•	Q ₁ Q ₁ EGG	E
Water, detergents, mineral oils mixture		23/176		•	•	•	•	Q ₁ Q ₁ VGG	V
Cleaning products		23/212		•	•	•	•	Q ₁ Q ₁ VGG	V
Diesel oil (•)	100	32/176	.033	•	•	•	•	Q ₁ BVGG	V
Kerosene (•)	100	32/176		•	•	•	•	Q ₁ BVGG	V
Fuel oil (•)		32/194	.027	•	•	•	•	Q ₁ BVGG	V
Glycerine	100	68/194	.046	•	•	•	•	Q ₁ BEGG	E
Sodium Hypochlorite	1	14/77			•		•	Q ₁ Q ₁ VGG	V
Phosphates/polyphosphates		23/194			•		•	Q ₁ Q ₁ VGG	V
Sodium nitrate	Saturated	14/176	.081	•	•	•	•	Q ₁ BEGG	E
Cutting fluid	100	23/230	.033	•	•	•	•	Q ₁ BVGG	V
Peanut oil (•)	100	23/230	.034	•	•	•	•	Q ₁ BEGG	E
Colza oil (•)	100	23/230	.034	•	•	•	•	Q ₁ BEGG	E
Linseed oil (•)	100	23/230	.034	•	•	•	•	Q ₁ BEGG	E
Coconut oil (•)	100	-4/194	.033	•	•	•	•	Q ₁ BEGG	E
Soybean oil (•)	100	32/194		•	•	•	•	Q ₁ BEGG	E
Diathermic oil	100	23/230	.033	•	•	•	•	Q ₁ BVGG	V
Hydraulic oil	100	23/230		•	•	•	•	Q ₁ BVGG	V
Mineral oil	100	23/230	.034	•	•	•	•	Q ₁ BVGG	V
Sodium sulfate	15	14/104	.094	•	•	•	•	Q ₁ Q ₁ EGG	E
Aluminium sulfate	30	23/122	.097		•		•	Q ₁ Q ₁ EGG	E
Ammonium sulfate	10	14/140	.064		•		•	Q ₁ Q ₁ EGG	E
Iron sulfate	10	23/86	.076		•		•	Q ₁ BEGG	E
Copper sulfate	20	32/86	.082		•		•	Q ₁ Q ₁ VGG	V
Trichloroethylene		14/104	.053	•	•	•	•	Q ₁ BVGG	V
Perchloroethylene		14/86	.057	•	•	•	•	Q ₁ BVGG	V

Legend

- Q₁ = Silicon carbide
- B = Impregnated carbon
- E = EPDM
- V = Viton
- G = AISI 316 (spring, metal components)

(•) A special version may be necessary for this fluid. For additional information, please contact our sales network.

Notes

Xylem |'zīləm|

- 1) The tissue in plants that brings water upward from the roots;
- 2) a leading global water technology company.

We're 12,500 people unified in a common purpose: creating innovative solutions to meet our world's water needs. Developing new technologies that will improve the way water is used, conserved, and re-used in the future is central to our work. We move, treat, analyze, and return water to the environment, and we help people use water efficiently, in their homes, buildings, factories and farms. In more than 150 countries, we have strong, long-standing relationships with customers who know us for our powerful combination of leading product brands and applications expertise, backed by a legacy of innovation.

For more information on how Xylem can help you, go to www.xyleminc.com



Xylem Inc.
1 Goulds Drive
Auburn, NY 13021
Phone: (800) 453-6777
Fax: (888) 322-5877
www.gouldswatertechnology.com

Goulds is a registered trademark of Goulds Pumps, Inc. and is used under license.
© 2011 Xylem Inc. BeSV50 R2 February 2013