

140 • 240 • 180 • 280 Series
**Regenerative
Turbine Pumps**

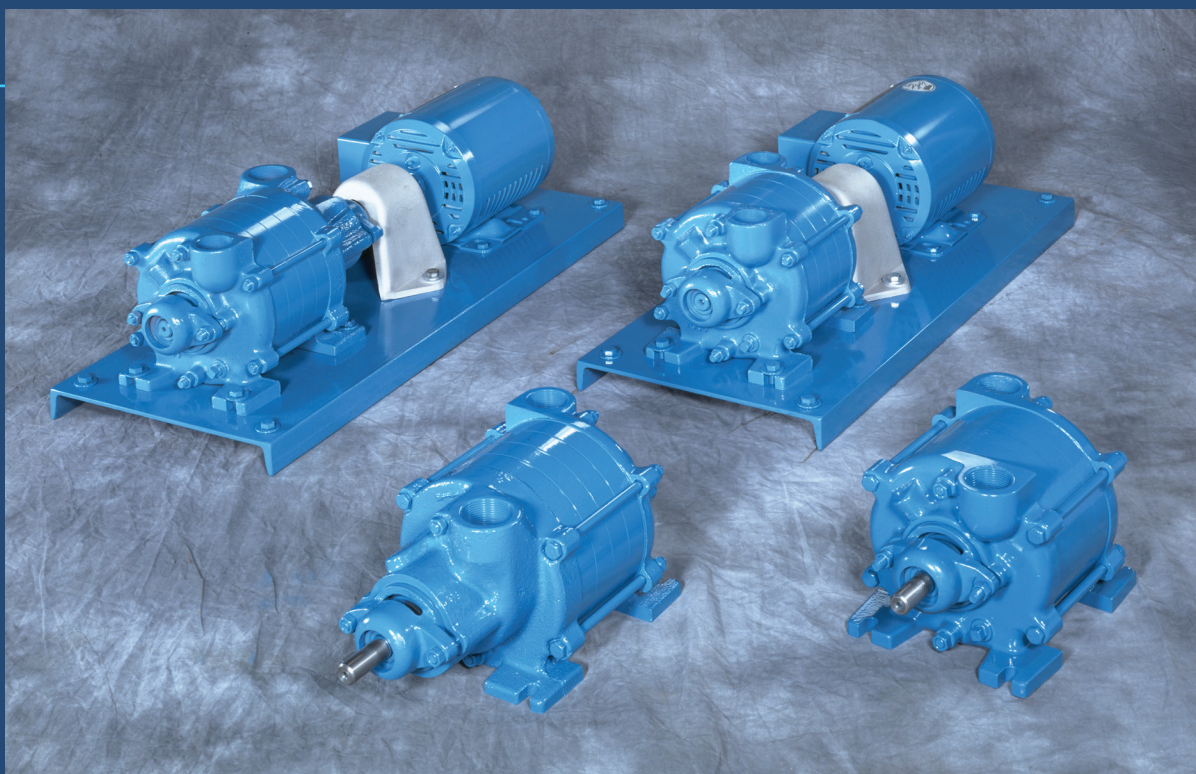

- Capacities to 60 GPM
- Heads to 800 Feet

 PumpCatalog.com

Questions? Call 1-800-810-1053

MTH PUMPS

140 • 240 • 180 • 280 Series Regenerative Turbine Pumps

140 • 240 • 180 • 280 Series regenerative turbine pumps represent the most economical, high performance alternative for low flow (to 60 GPM) applications involving moderate to high pressures (heads to 800 feet). By combining years of regenerative turbine pump designs with precision computer controlled manufacturing, the 140 • 240 • 180 • 280 Series delivers high efficiency pumping operation, even at low NPSH. High quality parts and an easily serviceable design provide low maintenance and long life.

Water Passage Design

MTH has combined seventy years of water passage design with a multi-stage mechanical concept to achieve maximum capacity and pressure while minimizing horsepower requirements. By optimizing the number of pumping stages with each water passageway, MTH improves both efficiency and pressure in the 140 • 240 • 180 • 280 Series, exceeding the standards realized by previous techniques.

Impeller Profile

One of the most notable improvements in regenerative turbine pump technology incorporated in 140 • 240 • 180 • 280 Series pumps involves

the ability to determine the optimum impeller width and blade length. These factors have a significant effect on the required horsepower versus pressure curve for regenerative turbine pumps. By optimizing these for each 140 • 240 • 180 • 280 Series pump, peak efficiency is improved and “off peak” horsepower requirements are reduced as well.

Impeller Blades

After the most favorable impeller profile has been determined for a particular water passageway cross-section, MTH calculates the number of blades needed to maximize the performance of that pump. Current blade design in 140 • 240 • 180 • 280 Series pumps increases both efficiency and design pressure without the manufacturing difficulties associated with producing contoured blade impellers.

State-of-the-art computer controlled machines simplify manufacturing of the various MTH impellers utilized in the 140 • 240 • 180 • 280 Series. The result is a high performance pump providing efficiency characteristics exceeding those of more expensive units.

NPSH Requirements

140 • 240 • 180 • 280 Series regenerative turbine pumps meet low net positive suction head (NPSH) requirements without efficiency loss. This is achieved by keeping the inlet fluid velocity low and then gently accelerating to passageway velocities.

Low NPSH Requirements

240 • 280 Series regenerative turbine pumps provide exceptionally low NPSH requirements to suit boiler feed water deaerator applications. This reduced NPSH is obtained by using a first stage centrifugal Francis vane impeller with inlet flow paths shaped to maintain a constant fluid velocity. This reduces entry losses to the impeller as well as maintaining pump efficiency. A multi-vane diffuser is used in conjunction with the centrifugal impeller for balancing radial loads and extracting the maximum pressure from the flow produced by the first stage impeller. Pressure and flow produced by the low NPSH inducer assures that the succeeding stages are adequately fed.

STANDARD MATERIALS

PART	BRONZE FITTED	ALL IRON	BRONZE RING	ALL BRONZE	STAINLESS STEEL
Cover	Cast Iron ASTM A48	Cast Iron ASTM A48	Cast Iron ASTM A48	Bronze ASTM B62	Stainless Steel AISI 316
Seal Cup	Cast Iron ASTM A48	Cast Iron ASTM A48	Cast Iron ASTM A48	Bronze ASTM B62	Stainless Steel AISI 316
Bearing Arm	Cast Iron ASTM A48	Cast Iron ASTM A48	Cast Iron ASTM A48	Bronze ASTM B62	Stainless Steel AISI 316
Channel Ring	Cast Iron ASTM A48	Cast Iron ASTM A48	Bronze ASTM B62	Bronze ASTM B62	Stainless Steel AISI 316
Impeller	Bronze ASTM B62	Carbon Steel 12L14	Bronze ASTM B62	Bronze ASTM B62	W88 ASTM A494
Shaft	Stainless Steel AISI 416	Stainless Steel AISI 416	Stainless Steel AISI 416	Stainless Steel AISI 316	Stainless Steel AISI 316
“O” Rings	Buna N	Buna N	Buna N	Buna N	Viton A
Seals	EPR/Carbon	EPR/Carbon	EPR/Carbon	Buna/Ceramic	Viton/Ceramic
Seats	EPR/Ceramic	EPR/Ni-Resist	EPR/Ni-Resist	Buna/Ceramic	Viton/Ceramic
Ball Bearing	#204	#204	#204	#204	#204

LIMITATIONS

Discharge Pressure	400 PSI
Seal Pressure*	200 PSI
Suction Pressure (Min)	26" Hg. Vac.
Speed	1750 RPM
Horsepower	15 HP

Temperature

Standard Construction	-20° F
Ceramic Seal Seat - Water	+230° F
Ni-Resist Seal Seat - Water	+230° F
Silicon Carbide Seal Seat & External Seal Flush	+250° F

* Suction Pressure Plus a Percentage of Differential Pressure



WARNING:
CANCER AND REPRODUCTIVE HARM
WWW.P65WARNINGS.CA.GOV

140 • 240 • 180 • 280 SERIES

Design Features

MTH 140 • 240 • 180 • 280 Series

regenerative turbine pumps are engineered to provide long life, low-maintenance service for low-flow applications involving moderate to high pressures -- such as boiler feed and similar uses. Available in single, two, three, or four stage models, MTH pumps offer these proven design features...

Steep Operating Characteristics.

Near-constant capacity is maintained over wide variations in pressure. High shut-off pressure overcomes temporary line resistance.

No Vapor Binding. MTH impellers are designed to handle up to 20% vapor by volume in the liquid being pumped.

No Metal to Metal Contact. MTH clearances enable handling of non-lubricating fluids while maintaining adequate heads.

Low Head Requirements. MTH pumps have excellent NPSH characteristics, which makes them ideally suited for difficult applications.

Minimum Shaft Deflection provided by heavy-duty outboard bearing supports on both sides of the impeller.

Balanced Radial Loads. On multi-stage MTH pumps, radial load equalization is designed into the pump, eliminating the need for external adjustment

Standard Pumps have hydraulically balanced impellers, 3/4" stainless steel shafts, and corrosion-resistant seals throughout.

400# Case Working Pressure.

Rigid structure is designed for maximum casing strength.

100% Tested.

Every pump is fully tested to verify performance prior to shipment.

Mechanical Seals incorporate EPR or Viton seals, ceramic or Ni-resist faces, and stainless steel components. These advanced seals permit elevated-temperature operation even with aggressive fluids.

Lip-Sealed #204 Ball Bearings

on both inboard and outboard ends, operate within rugged cast-

iron bearing supports and are permanently lubricated for long, maintenance-free life.

Replaceable Channel Rings, along with "O"rings at all sealing points, contribute to trouble-free operation.

Non-Cavitating.

140•240•180•280 Series pumps may be operated under adverse inlet conditions without audible or measurable cavitation.

Optional Features

Construction Materials. Bronze fitted, all iron, bronze ring, all bronze and 316 stainless steel are available as stock materials.

Mechanical Seals. Buna, EPR, Viton, Neoprene or Teflon elastomers, Ni-resist, Tungsten, or Silicone Carbide seats and balanced or double seal arrangements are all available.

"O"Ring Gaskets. Buna, EPR, Viton, Neoprene or Teflon are all available.

Seal Flush Line. External flush line from pump discharge to seal faces allow for higher fluid temperature.

External Water Seal Connection.

Tapped openings can be provided for seal flushing from an external source.

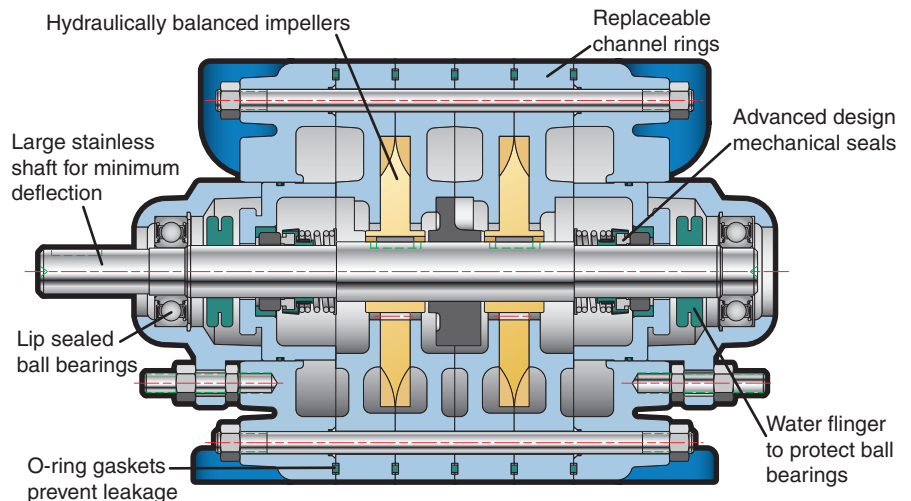

200 Series Inducer for Low NPSH

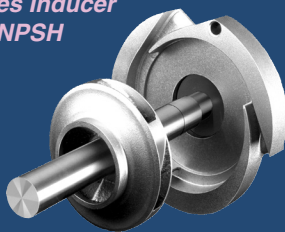

The 200 Series inducer style pumps are ideally suited to applications where available NPSH at the pump inlet is limited, such as boiler feed water deaerator service.

A centrifugal impeller with low NPSH characteristics is utilized as the pump's first stage impeller, providing for the lower inlet head requirement.

This first stage impeller is used in conjunction with a multi-vane diffuser to provide the NPSH required by the second stage regenerative turbine.

Available NPSH as low as one foot can be effectively handled with 240 • 280 Series pumps, depending on the pump model and capacity.

MTH PUMPS

Regenerative Turbine Education

The primary difference between a centrifugal and a regenerative turbine pump is that fluid only travels through a centrifugal impeller once, while in a turbine, it takes many trips through the vanes. Referring to the cross-section diagram, the impeller vanes move within the flow-through area of the water channel passageway. Once the liquid enters the pump, it is directed into the vanes which push the fluid forward and impart a centrifugal force outward to the impeller periphery. An orderly circulatory flow is therefore imposed by the impeller vane which is converted to velocity. Fluid velocity (or kinetic energy) is then available for conversion to flow and pressure depending on the external system's flow resistance as diagrammed by a system curve.

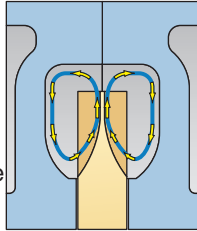

an MTH regenerative turbine, close internal clearances are required. In many cases, depending on the size of the pump, impeller to casing clearances may be as little as one-thousandth of an inch on each side. Therefore, these pumps are suitable for use only on applications with clean fluids and systems, or else the fluid must be pre-filtered before reaching the pump.

Next, as the circulatory flow is imposed on the fluid and it reaches the fluid channel periphery, it is then redirected by the specially shaped fluid channels, around the side of the impeller, and back into the I.D.

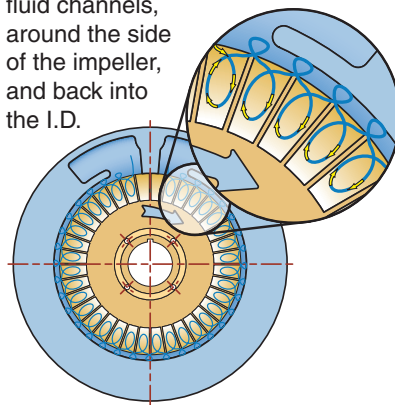

of the turbine impeller vanes, where the process begins again. This cycle occurs many times as the fluid passes through the pump. Each trip through the vanes generates more fluid velocity, which can then be converted into more pressure. The multiple cycles through the turbine vanes are called regeneration, hence the name regenerative turbine. The overall result of this process is a pump with pressure building capability ten or more times that of a centrifugal pump with the same impeller diameter and speed.

In some competitive designs, you will find that only a single-sided impeller is used. That design suffers from a thrust load in the direction of the motor that must be carried by the motor bearings. MTH turbines use a two-sided impeller design that builds pressure equally on both sides. This has the advantage of allowing the pump pressure to hydraulically self-center the impeller in the close clearance impeller cavity, while not burdening the motor bearings with excessive thrust loads.

It is useful to note at this point, that in order to prevent the internal loss of the pressure building capability of

140 • 240 • 180 • 280 SERIES

Engineering Specifications

140 • 180 Series

The contractor shall furnish (and install as shown on the plans) an MTH Turboflex regenerative type pump model _____ size _____ of (BRONZE FITTED) (BRONZE RING) (ALL IRON) (ALL BRONZE) (316 STAINLESS STEEL) construction. Each pump shall have a capacity of _____ GPM when operating at a total head of _____ feet at the specified temperature, viscosity, specific gravity, and with _____ feet NPSHA. The maximum speed shall not exceed 1750 RPM. Pump shall be of the vertically split case design with removable bearing housings and is to be furnished with mechanical seals. The channel rings shall be replaceable external type. The suction connection shall be _____" NPT located in the top vertical position and be cast separately from the discharge. The discharge shall be _____" NPT in the top vertical position and the pump shall be self-venting. The impeller(s) shall be located on a stainless steel shaft between sealed grease lubricated ball bearings. The impeller(s) shall be hydraulically self positioning with no external adjustment necessary. Each pump shall be tested at the specified capacity and head prior to shipment. The pump shall be mounted on a steel baseplate, flexibly coupled with aluminum guard to a _____ HP _____ phase _____

Hertz _____ volt _____ RPM horizontal (DRIP-PROOF) (TOTALLY ENCLOSED) (EXPLOSION PROOF) motor. The motor is to be sized to prevent overloading at the highest head condition listed in the specification.

240 • 280 Series

The contractor shall furnish (and install as shown on the plans) an MTH Turboflex low NPSH inducer style regenerative type pump model _____ size _____ of (BRONZE FITTED) (BRONZE RING) (ALL IRON) (ALL BRONZE) (316 STAINLESS STEEL) construction. Each pump shall have a capacity of _____ GPM when operating at a total head of _____ feet at the specified temperature, viscosity, specific gravity, and with _____ feet NPSHA. The maximum speed shall not exceed 1750 RPM. Pump shall be low NPSHR inducer style design with a centrifugal Francis vane design impeller and a multi-vane diffuser for balancing radial loads. Pump shall be of the vertically split case design with removable bearing housings and is to be furnished with mechanical seals. The channel rings shall be replaceable external type. The suction connection shall be _____" NPT located in the top vertical position and be cast separately from the discharge. The discharge shall be _____" NPT in the top

vertical position and the pump shall be self-venting. The impeller(s) shall be located on a stainless steel shaft between sealed grease lubricated ball bearings. The impeller(s) shall be hydraulically self positioning with no external adjustment necessary. Each pump shall be tested at the specified capacity and head prior to shipment. The pump shall be mounted on a steel baseplate, flexibly coupled with aluminum guard to a _____ HP _____ phase _____ Hertz _____ volt _____ RPM horizontal (DRIP-PROOF) (TOTALLY ENCLOSED) (EXPLOSION PROOF) motor. The motor is to be sized to prevent overloading at the highest head condition listed in the specification.



MTH PUMPS

401 West Main Street • Plano, IL 60545-1436
Phone: 630-552-4115 • Fax: 630-552-3688
Email: SALES@MTHPUMPS.COM
<http://WWW.MTHPUMPS.COM>

Cold Water Selection Guide

HEAD IN FEET	U.S. GALLONS PER MINUTE											
	4 Model HP	5 Model HP	6 Model HP	8 Model HP	10 Model HP	12 Model HP	15 Model HP	20 Model HP	25 Model HP	30 Model HP	40 Model HP	50 Model HP
25	*	*	*	141D .5	141E .5	141F .5	141G .5	141H .75	141I .75	141IA 1	181M 1.5	181P 1.5
50	*	*	141D .5	141E .5	141F .5	141G .5	141H .75	141I 1	181K 1	181M 1.5	181P 1.5	181R 2
75	*	*	141D .5	141E .5	141F .75	142F .75	141H 1	141I 1	141IA 1.5	181M 2	181R 3	182R 5
100	*	141D .5	141E .5	141F .75	142F .75	141H 1	141I 1	141IA 1.5	182K 2	181P 2	182P 3	183R 5
125	141D .75	141E .75	141E .75	141G 1	142F 1	142G 1.5	142H 1.5	142I 2	182K 2	182M 3	182P 3	183R 5
150	141E .75	141E .75	142D 1	143E 1	142G 1.5	143G 1.5	142H 2	143I 3	142IA 3	182M 5	182R 5	184R 7.5
175	141E 1	142D 1	142E 1	142F 1.5	142G 1.5	142H 2	142I 2	182K 3	143IA 3	182P 5	183P 5	
200	141E 1	142D 1	142E 1	142F 1.5	143F 1.5	142H 2	142I 3	142IA 3	183K 3	183M 5	183R 7.5	
225	142D 1.5	143D 1.5	142E 1.5	142F 1.5	143G 2	143H 3	142I 3	142IA 3	143IA 5	183P 5	184P 7.5	
250	142D 1.5	143D 1.5	142E 1.5	143F 2	143G 2	143H 3	143I 3	143IA 5	144IA 5	183P 5	184R 10	
300	143D 1.5	142E 1.5	143E 1.5	143F 2	143H 3	142I 3	143I 5	143IA 5	183P 7.5	184P 7.5		
350	144D 2	144D 2	143E 2	144F 3	144H 5	144H 5	143I 5	144IA 5	184M 7.5	184P 7.5		
400	144D 2	143E 2	144E 2	144G 3	144H 5	143I 5	144I 5	144IA 5	184P 7.5			
450	144D 2	143E 2	144E 2	144G 3	143I 5	144I 5	183K 7.5	184P 10	184R 15			
500	144D 3	144E 3	144F 3	143I 7.5	143I 7.5	144I 7.5	144IA 7.5					
550	143E 3	144E 3	143I 5	143I 5	144I 7.5	144IA 7.5						
600	144E 3	144G 5	143I 7.5	144I 7.5	144I 7.5	144IA 7.5						
650	144E 3											
700	144E 3											

Selections based on coldwater flooded suction 1.0 S.G. Open Dripproof Motor. Consult individual pump curve for final selection. *Refer to T41 Series Bulletin.

Boiler Feed Selection Guide

Boiler HP	Evap Rate GPM	Pump GPM	BOILER PRESSURE IN PSI													
			15		50		100		125		150		200		250	
			Model	HP	Model	HP	Model	HP	Model	HP	Model	HP	Model	HP	Model	HP
15	1.0	3.1	141D	.3	141D	.75	142E	1.0	142E	1.5	142F	1.5	143E	2.0	144E	3.0
20	1.4	4.1	141D	.3	141D	.75	142E	1.0	142E	1.5	142F	1.5	143E	2.0	144E	3.0
25	1.7	4.4	141D	.3	141D	.75	142E	1.0	142E	1.5	143E	1.5	143E	2.0	144E	3.0
30	2.1	5.0	141D	.3	141D	.75	142E	1.0	142E	1.5	143E	1.5	143E	2.0	144E	3.0
40	2.8	5.6	141D	.3	141E	.75	142F	1.5	142G	2.0	143E	1.5	144F	3.0	144I	7.5
50	3.5	7.0	141D	.3	141F	.75	142F	1.5	143F	2.0	143F	2.0	144I	5.0	144I	7.5
60	4.2	8.3	141E	.3	141F	.75	142G	2.0	143G	2.0	143G	5.0	144I	5.0	144I	7.5
70	4.8	9.6	141F	.5	141I	1.5	142I	3.0	143I	3.0	143I	5.0	144I	5.0	144I	7.5
80	5.5	11.0	141F	.5	141I	1.5	142I	3.0	143I	3.0	143I	5.0	144I	5.0	144I	7.5
100	6.9	14.0	141G	.5	141I	1.5	142IA	3.0	143I	3.0	143IA	5.0	144I	5.0	152I	10.0
125	8.6	17.5	141I	.75	141IA	1.5	142IA	3.0	143I	3.0	143IA	5.0	144IA	7.5	152I	10.0
150	10.7	21.0	141I	.75	141IA	1.5	151I	5.0	143IA	5.0	144IA	5.0	152I	7.5	153I	10.0
200	13.8	28.0	141IA	1.0	182K	2.0	151K	5.0	152I	5.0	162D	7.5	162D	10.0	163D	15.0
250	17.3	33.0	181M	1.5	151K	3.0	152K	5.0	152K	7.5	162D	7.5	162G	10.0	153L	15.0
300	20.7	38.0	181M	1.5	151K	3.0	152K	5.0	152K	7.5	152L	10.0	162G	15.0	153L	15.0
350	24.2	43.0	181P	1.5	151L	5.0	152L	7.5	152L	10.0	152L	10.0	162G	15.0	153L	15.0
400	27.6	48.0	181R	2.0	151L	5.0	162L	7.5	152L	10.0	162G	15.0	162G	15.0	163G	20.0
500	34.5	57.0	151L	3.0	161G	5.0	162G	10.0	162G	10.0	163G	15.0	164G	20.0	173H	25.0
600	41.5	71.0	161G	3.0	161G	5.0	172H	15.0	172H	15.0	172J	20.0	173H	20.0	173K	30.0
700	43.5	77.0	161G	3.0	171K	7.5	172K	15.0	172K	15.0	173K	20.0	174H	20.0	174J	30.0

NOTES

Selections are for water at 200°F (Maximum) with above 3 feet NPSHA (Net Positive Suction Head Available) over NPSHR (Net Positive Suction Head Required). All pumps are selected for intermittent (on-off) operation and with ODP (Open Drip Proof) motors operating at 1750RPM. This selection is for reference only. Refer to the technical data of the specific model number to ascertain the suitability of the model in your application, or call the factory. 150 • 160 • 170 Model pump information is available in our Bulletin 150.

Dimensions

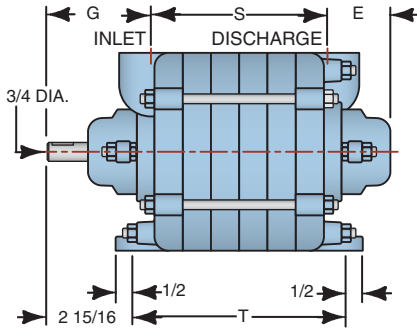

Pump Only Dimensions

PUMP SERIES	INLET	DISCHARGE	E	G	S	T
141	1 1/4" NPT	1 1/4" NPT	2 1/8	3 13/16	4 1/4	6
142	1 1/4" NPT	1 1/4" NPT	2 1/8	3 13/16	6 1/4	8
143	1 1/4" NPT	1 1/4" NPT	2 1/8	3 13/16	8 1/4	10
144	1 1/4" NPT	1 1/4" NPT	2 1/8	3 13/16	10 1/4	12
181	1 1/2" NPT	1 1/2" NPT	2 1/4	3 11/16	5 1/2	7
182	1 1/2" NPT	1 1/2" NPT	2 1/4	3 11/16	8 1/2	10
183	1 1/2" NPT	1 1/2" NPT	2 1/4	3 11/16	11 1/2	13
184	1 1/2" NPT	1 1/2" NPT	2 1/4	3 11/16	14 1/2	16

ROTATION: Clockwise when viewed from driver end.

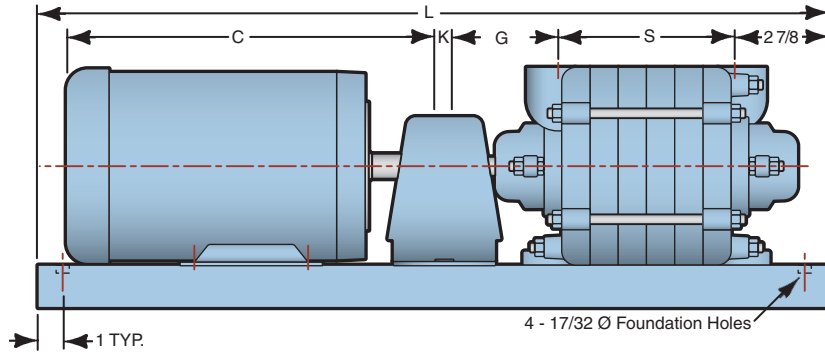
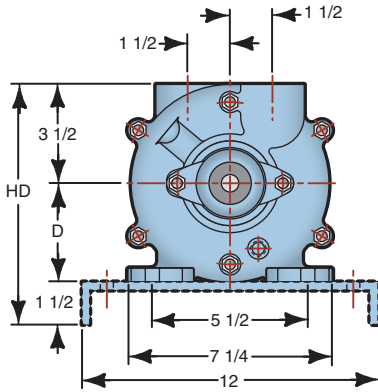

140 Series Flex Coupled Pump Dimensions

FRAME	CPLG	ALL 140 MODELS				MODEL 141		MODEL 142		MODEL 143		MODEL 144	
		K	D	HD	C	S	L	S	L	S	L	S	L
56	3J	3/8	3 1/2	8 1/2	12	4 1/4	24	6 1/4	26	8 1/4	28	10 1/4	30
143T	4J	5/8	3 1/2	8 1/2	13	4 1/4	24	6 1/4	26	8 1/4	28	10 1/4	30
145T	4J	5/8	3 1/2	8 1/2	14	4 1/4	24	6 1/4	26	8 1/4	28	10 1/4	30
182T	5J	3/4	4 1/2	9 1/2	16	4 1/4	26	6 1/4	30	8 1/4	32	10 1/4	35
184T	5J	3/4	4 1/2	9 1/2	17	---	---	6 1/4	30	8 1/4	32	10 1/4	35
213T	6J	7/8	5 1/4	10 1/4	19	---	---	---	---	8 1/4	35	10 1/4	40
215T	6J	7/8	5 1/4	10 1/4	20	---	---	---	---	---	---	10 1/4	40

180 Series Flex Coupled Pump Dimensions

FRAME	CPLG	ALL 180 MODELS				MODEL 181		MODEL 182		MODEL 183		MODEL 184	
		K	D	HD	C	S	L	S	L	S	L	S	L
56	3J	3/8	3 1/2	8 1/2	12	5 1/2	26	8 1/2	28	11 1/2	30	14 1/2	35
143T	4J	5/8	3 1/2	8 1/2	13	5 1/2	26	8 1/2	28	11 1/2	30	14 1/2	35
145T	4J	5/8	3 1/2	8 1/2	14	5 1/2	26	8 1/2	28	11 1/2	30	14 1/2	35
182T	5J	3/4	4 1/2	9 1/2	16	5 1/2	28	8 1/2	30	11 1/2	32	14 1/2	40
184T	5J	3/4	4 1/2	9 1/2	17	5 1/2	28	8 1/2	30	11 1/2	32	14 1/2	40
213T	6J	7/8	5 1/4	10 1/4	19	---	---	8 1/2	35	11 1/2	40	14 1/2	45
215T	6J	7/8	5 1/4	10 1/4	20	---	---	8 1/2	35	11 1/2	40	14 1/2	45

NOTES

All dimensions in inches. May vary ± 1/4 inches.
 Not for construction purposes unless certified.
 ROTATION: Clockwise when viewed from driver end.

240 • 280 SERIES

Dimensions

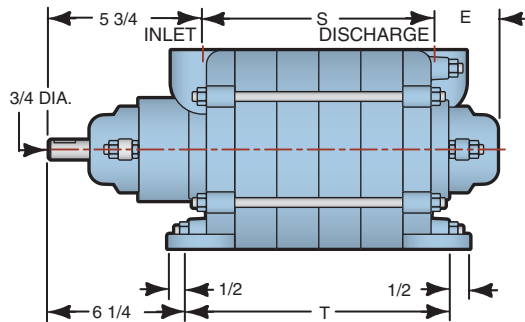

Pump Only Dimensions

PUMP SERIES	INLET	DISCHARGE	E	S	T
241	1 1/2" NPT	1 1/4" NPT	2 1/8	5 5/8	6
242	1 1/2" NPT	1 1/4" NPT	2 1/8	7 5/8	8
243	1 1/2" NPT	1 1/4" NPT	2 1/8	9 5/8	10
244	1 1/2" NPT	1 1/4" NPT	2 1/8	11 5/8	12
281	1 1/2" NPT	1 1/2" NPT	2 1/4	6 5/8	7
282	1 1/2" NPT	1 1/2" NPT	2 1/4	9 5/8	10
283	1 1/2" NPT	1 1/2" NPT	2 1/4	12 5/8	13
284	1 1/2" NPT	1 1/2" NPT	2 1/4	15 5/8	16

ROTATION: Clockwise when viewed from driver end.

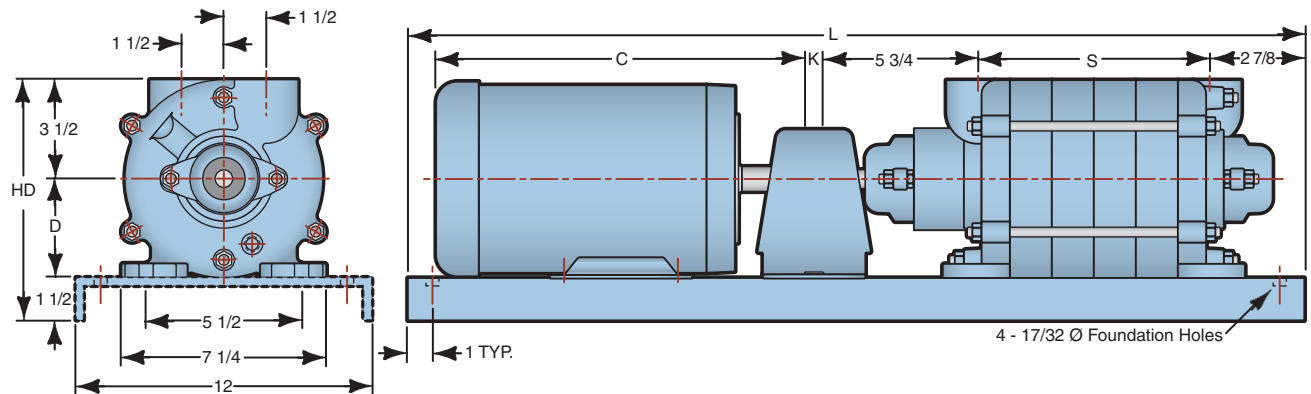

240 Series Flex Coupled Pump Dimensions

FRAME	CPLG	ALL 240 MODELS				MODEL 241		MODEL 242		MODEL 243		MODEL 244	
		K	D	HD	C	S	L	S	L	S	L	S	L
56	3J	3/8	3 1/2	8 1/2	12	5 5/8	28	7 5/8	30	9 5/8	32	11 5/8	35
143T	4J	5/8	3 1/2	8 1/2	13	5 5/8	28	7 5/8	30	9 5/8	32	11 5/8	35
145T	4J	5/8	3 1/2	8 1/2	14	5 5/8	28	7 5/8	30	9 5/8	32	11 5/8	35
182T	5J	3/4	4 1/2	9 1/2	16	5 5/8	30	7 5/8	32	9 5/8	35	11 5/8	38
184T	5J	3/4	4 1/2	9 1/2	17	5 5/8	30	7 5/8	32	9 5/8	35	11 5/8	38
213T	6J	7/8	5 1/4	10 1/4	19	---	---	---	---	9 5/8	40	11 5/8	40
215T	6J	7/8	5 1/4	10 1/4	20	---	---	---	---	9 5/8	40	11 5/8	40

280 Series Flex Coupled Pump Dimensions

FRAME	CPLG	ALL 280 MODELS				MODEL 281		MODEL 282		MODEL 283		MODEL 284	
		K	D	HD	C	S	L	S	L	S	L	S	L
56	3J	3/8	3 1/2	8 1/2	12	6 5/8	28	9 5/8	32	12 5/8	35	15 5/8	38
143T	4J	5/8	3 1/2	8 1/2	13	6 5/8	28	9 5/8	32	12 5/8	35	15 5/8	38
145T	4J	5/8	3 1/2	8 1/2	14	6 5/8	28	9 5/8	32	12 5/8	35	15 5/8	38
182T	5J	3/4	4 1/2	9 1/2	16	6 5/8	30	9 5/8	35	12 5/8	38	15 5/8	40
184T	5J	3/4	4 1/2	9 1/2	17	6 5/8	30	9 5/8	35	12 5/8	38	15 5/8	40
213T	6J	7/8	5 1/4	10 1/4	19	---	---	---	---	12 5/8	40	15 5/8	42
215T	6J	7/8	5 1/4	10 1/4	20	---	---	---	---	12 5/8	40	15 5/8	42

NOTES

All dimensions in inches. May vary $\pm 1/4$ inches.
 Not for construction purposes unless certified.
 ROTATION: Clockwise when viewed from driver end.

Order Online: www.PumpCatalog.com



MTH PUMPS

401 West Main Street • Plano, IL 60545-1436
Phone: 630-552-4115 • Fax: 630-552-3688
Email: Sales@MTHPumps.com
[Http://WWW.MTHPumps.com](http://WWW.MTHPumps.com)